

Anonyme. The Journal of physical chemistry. Published at Cornell university [puis Published under the auspices of the American chemical society, the Chemical society and the Faraday society]. 1896 [I]-. 1913.

1/ Les contenus accessibles sur le site Gallica sont pour la plupart des reproductions numériques d'oeuvres tombées dans le domaine public provenant des collections de la BnF. Leur réutilisation s'inscrit dans le cadre de la loi n°78-753 du 17 juillet 1978 :

\*La réutilisation non commerciale de ces contenus est libre et gratuite dans le respect de la législation en vigueur et notamment du maintien de la mention de source.

\*La réutilisation commerciale de ces contenus est payante et fait l'objet d'une licence. Est entendue par réutilisation commerciale la revente de contenus sous forme de produits élaborés ou de fourniture de service.

Cliquer [ici](#) pour accéder aux tarifs et à la licence

2/ Les contenus de Gallica sont la propriété de la BnF au sens de l'article L.2112-1 du code général de la propriété des personnes publiques.

3/ Quelques contenus sont soumis à un régime de réutilisation particulier. Il s'agit :

\*des reproductions de documents protégés par un droit d'auteur appartenant à un tiers. Ces documents ne peuvent être réutilisés sauf dans le cadre de la copie privée sans l'autorisation préalable du titulaire des droits.

\*des reproductions de documents conservés dans les bibliothèques ou autres institutions partenaires. Ceux-ci sont signalés par la mention Source Gallica.BnF.fr / Bibliothèque municipale de ... (ou autre partenaire). L'utilisateur est invité à s'informer auprès de ces bibliothèques de leurs conditions de réutilisation.

4/ Gallica constitue une base de données, dont la BnF est producteur, protégée au sens des articles L341-1 et suivants du code la propriété intellectuelle.

5/ Les présentes conditions d'utilisation des contenus de Gallica sont régies par la loi française. En cas de réutilisation prévue par un autre pays, il appartient à chaque utilisateur de vérifier la conformité de son projet avec le droit de ce pays.

6/ L'utilisateur s'engage à respecter les présentes conditions d'utilisation ainsi que la législation en vigueur, notamment en matière de propriété intellectuelle. En cas de non respect de ces dispositions, il est notamment passible d'une amende prévue par la loi du 17 juillet 1978.

7/ Pour obtenir un document de Gallica en haute définition, contacter [reutilisation@bnf.fr](mailto:reutilisation@bnf.fr).

---

***Journal of physical  
chemistry***

**Tome 17**

**Volume 17**

***Washington* 1913**



CPg 4

THE JOURNAL  
OF  
PHYSICAL CHEMISTRY

*Editor*

WILDER D. BANCROFT

*Associate Editors*

H. T. BARNES  
S. L. BIGELOW  
F. K. CAMERON  
E. C. FRANKLIN

G. A. HULETT  
L. KAHLBERG  
W. L. MILLER  
J. L. R. MORGAN

T. B. ROBERTSON  
H. SCHLUNDT  
E. P. SCHOCH  
J. W. WALKER

VOLUME XVII



ITHACA, N. Y.  
THE EDITOR

LEIPZIG: BERNH. LIEBISCH  
for the Continent of Europe

1913



CONTENTS OF VOLUME XVII

1. JANUARY

J. M. Lohr, Herbert E. Ives,	The Tensile Strength of the Copper-Zinc Alloys, Recent Advances in our Knowledge of Cold Light,	1 26
Francis C. Frary, Ralph W. Mitchell and Rus- sell E. Baker,	The Direct Production of Positives in the Camera by Means of Thiourea and its Compounds,	33
Herbert E. Ives, M. A. Gordon, New Books,	The Present Condition of Color Photography, The Silver Equivalent of Hydroquinone,	41 47 83

2. FEBRUARY

Wilder D. Bancroft, Albert P. Mathews,	The Photographic Plate, IX, A Method of determining "a" of van der Waals' Equation	93 154
Leon I. Shaw, New Books,	Studies in the Electrical Conductance of Non- Aqueous Solutions,	162 177

3. MARCH

Albert P. Mathews,	The Relation of the Value "a" of van der Waals' Equation to the Molecular Weight and the Number of Valences of the Molecule,	181
Alan Leighton, J. Howard Mathews and Leon H. Dewey,	The Photosensitiveness of Fehling's Solution, A Quantitative Study of Some Photochemical Ef- fects Produced by Ultra-Violet Light,	205 211
Edward G. Parker, J. Howard Mathews and Leon H. Dewey,	Studies on Cellulose, The Production of Photochemically Active Rays in Ordinary Chemical Reactions,	219 230
G. A. Perley and Alan Leighton,	Preliminary Studies on Direct Photographic Positives,	235
Ernest Anderson and H. A. Noyes,	A Simple, Inexpensive Calorimeter for Determin- ing the Heat of Solution and of Neutraliza- tion,	249
Albert P. Mathews, Stewart J. Lloyd, New Books,	The Valence of Chlorine as determined from the Molecular Cohesion of Chlorine Compounds, Conductivity Maxima in Glycerine,	252 264 268

4. APRIL

T. Roland Briggs,	The Electrochemical Production of Colloidal Copper,	281
-------------------	--	-----

Albert P. Mathews, C. W. Bennett and H. N. Gilbert, Albert P. Mathews,	A Note on the Structure of Acetylene, . . . . . Some Tests of the Edison Storage Battery, . . . . . The Valence of Oxygen, Sulphur, Nitrogen, and Phosphorus determined from the Molecular Cohesion, . . . . .	320 322 331
Albert P. Mathews,	The Valence of the Argon Group as determined from the Molecular Cohesion, . . . . .	337
Richard Beutner,	New Electric Properties of a Semipermeable Membrane of Copper Ferrocyanide, . . . . .	344
New Books,		361
5. MAY		
C. W. Bennett and C. O. Brown,	Concentration Changes in the Electrolysis of Cop- per Sulphate Solutions, . . . . .	373
M. M. Garver,	On the Molecular Constitution of the Free Sur- faces of Liquids, . . . . .	386
Henry L. Doyle,	Colloidal Suspension of Graphite, . . . . .	390
George B. Frankforter and Francis C. Frary,	Equilibria in Systems containing Alcohol, Salts and Water, including a New Method of Alco- hol Analysis, . . . . .	402
New Books,		474
6. JUNE		
Albert P. Mathews,	The Significance of the Relationship between Molecular Cohesion and the Product of the Molecular Weight and the Number of Val- ences, . . . . .	481
Wilder D. Bancroft, Albert P. Mathews,	The Theory of Emulsification, V, Do Molecules attract cohesively inversely as the Square of the Distance? . . . . .	501 520
H. B. Weiser, D. T. Wilber,	Indirect Analysis of a Ferric Oxide Gel, . . . . . Anhydrous Sodium Sulphate and Water, . . . . .	536 556
New Books,		558
7. OCTOBER		
Guy B. Taylor and George A. Hulett, Stewart J. Lloyd,	The Dissociation of Mercuric Oxide, . . . . . Electrical Conductivity of Solutions of Molyb- denum Pentachloride, . . . . .	565 592
Wilder D. Bancroft, Albert P. Mathews, J. L. Osborne,	The Electrochemistry of Light, X, The Internal Pressures of Liquids, . . . . . The Filtration of Barium Sulphate, . . . . .	596 603 629
New Books,		632
8. NOVEMBER		
E. F. Farnau, S. W. Young and L. N. Fingree,	Luminescence, . . . . . The Effect of Light on the Electrical Charge of Suspended Particles, . . . . .	637 657

*Contents of Volume XVII*

iii

J. M. Lohr,	Color Photography of Luminescence, . . .	675
J. Howard Mathews and Floyd E. Barmeler,	The Rôle Played by the Carbonate in Photo- graphic Development, . . .	682
C. W. Bennett and C. O. Brown,	Rapid Refining of Copper with a Rotating Cathode, . . .	685
Alan Leighton,	Effect of Light on Decomposition Voltage, . . .	695
F. R. Newman,	Action of Calcium Chloride on Roads, . . .	703
New Books,		707
9. DECEMBER		
D. Tyrer,	Some New Relations between the Physical Prop- erties of Liquids, . . .	717
A. W. Davison,	Experiments in Dyeing, . . .	737
Guy B. Taylor and George A. Hulett,	Mercuric Oxide, . . .	755
Nathaniel T. Bacon,	On the Mechanical Processes of Combination, . . .	762
E. H. Bunce and L. S. Finch,	Chromic Oxide Jellies, . . .	769
Elton L. Quinn and George A. Hulett,	The Atomic Weight of Cadmium by the Inves- tigation of Cadmium Chloride and Cadmium Bromide, . . .	779
New Books,		799
Name Index,		808
Index to New Books,		811
Subject Index,		813





## THE TENSILE STRENGTH OF THE COPPER-ZINC ALLOYS<sup>1</sup>

BY J. M. LOHR

The following investigation was undertaken for the purpose of establishing the relationship between the constitution of the copper-zinc alloys and their tensile strengths. For a long time such a series of data has been badly needed. Although brass has been used commercially for many years, it was only eight years ago that the equilibrium diagram was worked out, and it is not strange that, prior to that time, investigations on the various physical properties were made largely without any scientific basis as a guide for the work and for the interpretation of the results.

As early as 1842, Mallet<sup>2</sup> reported upon the specific gravities, color and character of fracture, tensile strengths, order of ductility, order of malleability, order of hardness and order of fusibility of the brasses. He used twenty-three pieces to cover the whole series, while only eleven of these covered the useful alloys. These alloys contained from about 47 to 100 percent copper, which are the percentages used in this work.

However, the most comprehensive work on this subject was that of the United States Board for Testing Materials, conducted by the Committee on Alloys under the chairmanship of Dr. R. H. Thurston.<sup>3</sup> This work was very extensive, and hence no part of it could be studied in detail. Forty-two pieces were used in the series of tests, twenty-three of which cover the useful part of the series.

More recently, important researches have been made on the effects of heat treatment, the principal ones of which

<sup>1</sup> A paper read before the Eighth International Congress of Applied Chemistry in New York, September, 1912.

<sup>2</sup> Phil. Mag., [3] 21, 66 (1842).

<sup>3</sup> Thurston: Materials of Engineering, Part 3.



are by Charpy,<sup>1</sup> Girard,<sup>2</sup> Cubillo,<sup>3</sup> and Bengough and Hudson.<sup>4</sup> In most cases, these have been intensive studies of alloys with definite compositions, rather than upon a series of different compositions.

### The Equilibrium Diagram

In Fig. 1, the equilibrium diagram for the copper-zinc series is shown, as worked out by Shepherd,<sup>5</sup> and recently very slightly modified by Carpenter and Edwards.<sup>6</sup> The coordinates are temperatures and percentage composition. The various lines on the diagram show where certain chemical or physical changes take place. The upper heavy lines, or

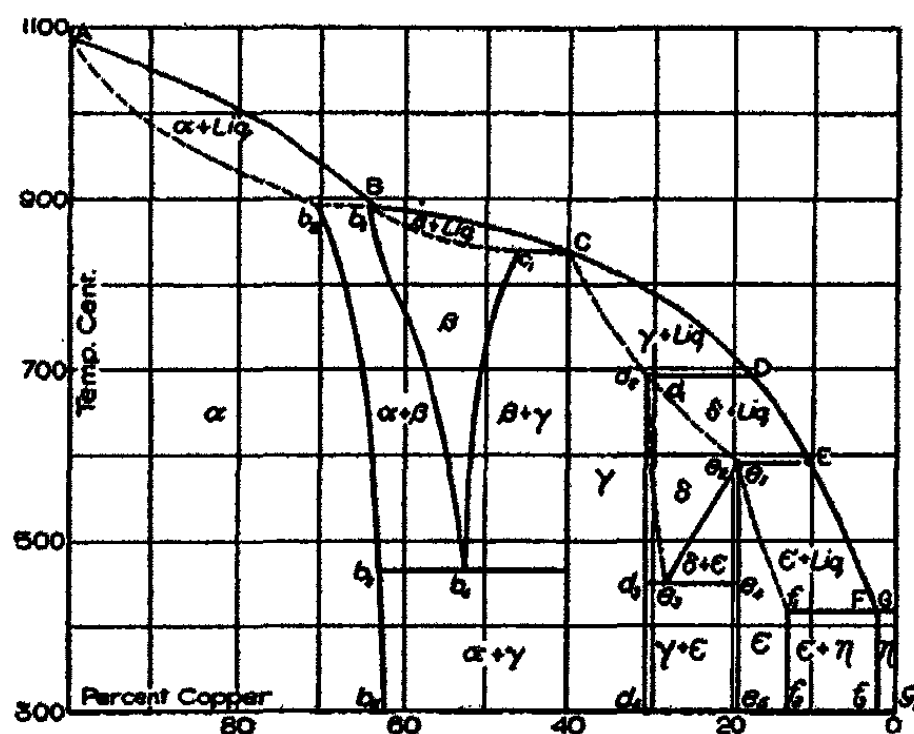

Fig. 1

liquidus, represent the temperatures above which the alloys are completely melted. The dotted lines or solidus, just below,

- <sup>1</sup> Bulletin de la Société d'Encouragement de l'Étude des Alliages, page 1.  
<sup>2</sup> Revue de Metallurgie, 1909; Mémoires, page 1069.  
<sup>3</sup> Proc. Inst. Mech. Eng., 791 (1905).  
<sup>4</sup> Jour. Soc. Chem. Ind., 27, 43, 654 (1908); Engineering, 90, 447 (1910).  
<sup>5</sup> Jour. Phys. Chem., 8, 421 (1904).  
<sup>6</sup> Engineering, 91, 200 (1911); 92, 431 (1912); Jour. Inst. Metals, 7, 70 (1912).

show the limits below which the alloys are completely solid. Between these lines crystals and melt co-exist.

In the diagram, the field marked  $a$  shows the concentration and temperatures over which pure crystals are stable under equilibrium conditions. These crystals are composed of a solid solution of zinc in copper, and show the same fern leaf-like structure throughout. Likewise,  $\beta$ ,  $\gamma$ ,  $\delta$ ,  $\epsilon$ , and  $\eta$  show definite crystal forms in their respective fields as indicated. Also, as we pass from  $a$  to  $\beta$  we find a field  $b_1, b_2, b_3, b_4$ , which is not composed of pure  $a$  or pure  $\beta$  crystals, but is a mixture of these two, which is richer in  $a$  crystals on the side bordering on pure  $a$ , and richer in  $\beta$  as we approach the field of pure  $\beta$ . Similarly we find fields composed of  $a + \gamma$ ,  $\beta + \gamma$ ,  $\gamma + \epsilon$ ,  $\delta + \epsilon$  and  $\epsilon + \eta$ .

Let us now trace the chemical changes which occur in the cooling of an alloy of a given composition. An alloy of, for example, 55 percent copper, is in the molten condition somewhere above  $880^\circ$ , the temperature at which it begins to solidify. Between this temperature and that represented by the dotted line, which is about  $860^\circ$ ,  $\beta$  crystals begin to separate from the mother liquor. These continue to separate as the temperature drops. When the dotted line, or solidus, is reached the melt freezes completely, and the mass is composed of pure  $\beta$  crystals. As the mass continues to cool,  $\beta$  crystals begin to break down into  $a$  crystals. This change begins at about  $600^\circ$ . As the cooling progresses, more and more  $\beta$  crystals break down into  $a$  crystals. Thus we have a mixture of  $a + \beta$  crystals, until we reach a temperature of  $470^\circ$ , at which point the  $\beta$  crystals break down into  $\gamma$  crystals. Below this temperature we find a mixture of  $a + \gamma$  crystals. This condition results from very slow cooling. If, however, we take the same 55 percent alloy, cool slowly, and then heat it to some high temperature, somewhere below the initial freezing point, for example  $800^\circ$ , and hold it there until equilibrium conditions are attained, it will be composed of pure  $\beta$  crystals. If quenched quickly in water from this

temperature, the  $\beta$  crystals do not have time to change over into  $\alpha$  crystals, and at ordinary temperatures the alloy retains the same crystalline structure which it had at 800°. One could, therefore, determine the strength of a pure  $\beta$  alloy by annealing a 55 percent alloy at 800°, or any other temperature falling within the  $\beta$  field, until equilibrium is reached, and then quench it rapidly; or, what is equivalent, if we quench the bar immediately after casting, we attain practically the same results.

As the alloys containing less than 50 percent copper are extremely brittle, and not used very extensively in technical work, this report covers only the  $\alpha$ ,  $\alpha + \beta$ ,  $\beta$  and a very small portion of the  $\beta + \gamma$  fields.  $\alpha + \gamma$  does not enter into it as all quenching was done considerably above 470°—the upper limit of this field.

#### Materials and Apparatus

The crucibles used in this work were made from cylinders of Acheson graphite. Three sizes, measuring respectively, 4, 6, and 8 inches in diameter and 6, 8, and 10 inches in height (outside dimensions), were employed. The smallest crucible contained the melt and was placed inside the one of medium size; the reason for this will be given later. These crucibles were turned from the cylinders by placing them in a lathe and using ordinary machine tools. It must be noted, however, in passing, that graphite dulls the edges of tools very quickly, making it almost impossible to keep tools sharp. But this is not a serious handicap as the material cuts easily. These graphite crucibles were entirely satisfactory in every respect except durability. It was impossible to prevent the heat from burning away the surface of the crucibles. In most cases about twenty-five pourings were made from a single crucible, although in the lower melting alloys many more were made. Dixon crucibles were also tried but they proved unsatisfactory for this work, chiefly because they chipped easily, and furthermore they could not be adapted to the method of pouring employed here.



About 1600 grams of metal were used for one pouring. Experiments were made with amounts varying from 1500 to 2000 grams, but no advantage seemed to be gained by using more than 1600 grams.

The heating was done in a 30 k. w. electric resistance furnace. It was  $34 \times 23 \times 15$  inches and was built of Queen's Run fire brick and cement. The walls were 4 inches thick—the width of a brick. The electrodes were made of Acheson graphite  $2 \times 4$  inches (made up of two  $2 \times 2$  inches) and extended inward through the ends of the furnace about 7 inches, with 4 inches outside the furnace walls. These electrodes were held in place by water-cooled electrode holders.<sup>1</sup> Fig. 2 shows a top view of the furnace. A is the brick wall, B a thick lining of siloxicon to prevent loss of heat by radiation, D the space occupied by granular carbon, C crucibles, E electrodes, and F electrode holders. A layer of siloxicon about an inch thick was also placed above and below the granular carbon.

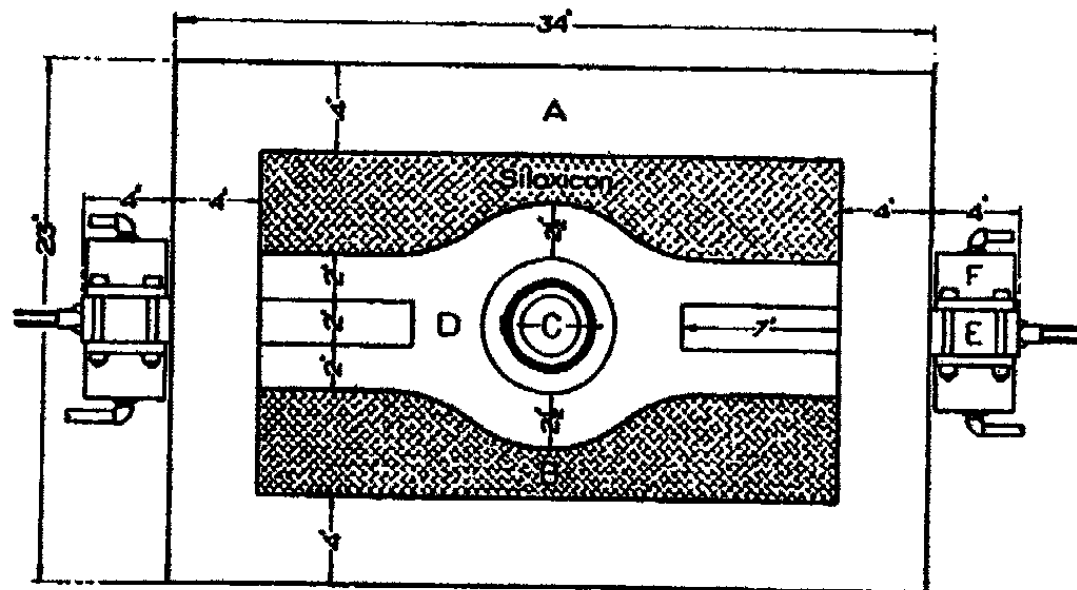

Fig. 2

The outer crucible (the medium size mentioned above) was kept stationary in the furnace, with its top very nearly on a level with the upper layer of siloxicon, so as to prevent

<sup>1</sup> Gillett: Jour. Phys. Chem., 15, 213 (1911)

burning away as much as possible. The smaller crucible containing the charge rested in this one, being on a level with the top. A small piece was cut from the inner edge of the outer crucible, to admit taking hold of the inner one with tongs. By this arrangement the crucible containing the charge could be removed at will, without tearing out the furnace charge.

The heating was usually begun with about 125 volts across the terminals; as the temperature rose the resistance decreased, and the voltage dropped to about 50 volts where it was held throughout the greater part of the run. This furnace could easily attain a temperature of 1200°, which was ample for this work.

The moulds<sup>1</sup> were made of two slabs of Acheson graphite, each 1 × 5 × 17 inches. The pattern of the casting consisted of the centrifugal spew,  $\frac{3}{4}$  inch in diameter, the test-piece ten inches in length, and the riser 1  $\frac{1}{4}$  inches in diameter. The test-pieces were cast to size for testing, and were composed of the test section 0.40 inch in diameter and six inches in length, and the grips at the ends 0.75 inch in diameter.

When casting test-pieces to size, the size of the riser is very important. If too small, an insufficient amount of metal is carried beyond the test-piece proper, and consequently any slag or oxide carried along in the pouring may lodge in the test-piece and render it faulty.

The moulds were made as needed. A mould could be used for about seventy-five castings. The greatest wear upon the moulds resulted from the effect of heating, which gradually burned away the outside, especially the bottom, causing the metal to run through when poured into the mould. In the preparation of the moulds, the graphite slabs were first made smooth on one side by means of a planer or shaper, so as to enable them to be clamped tightly together. This planing is usually necessary, as the slabs are generally somewhat warped when received from the factory. Most of the

<sup>1</sup> Shepherd and Upton: *Jour. Phys. Chem.*, 9, 441 (1905).

cutting was done by means of ordinary carpenter's gouges, but care had to be taken in making the grooves for the test section. After cutting out the grooves roughly, the smooth inside finish was most satisfactorily produced by means either of discarded safety razor blades rounded on end and made into scrapers, or short pieces of glass tubing of the proper diameter with sharp ends.

Probably the greatest difficulty encountered in this work was that of pouring. The mould was first placed in a level position, but it was impossible to fill the test-piece portion at the far end. This was due to the hot metal freezing too quickly in the bottom portion of the test-piece, and thereby leaving unfilled gaps on top. It was noticed, however, that the metal in the riser was always homogeneous and of good quality. This was, of course, filled from the bottom. Hence it seems wise to raise the far end of the mould so that the part occupied by the test-piece would fill by being pushed up the incline by the weight of the metal. This was an improvement, but it was finally found that it could only be filled satisfactorily by both inclining and heating the mould. A large box was therefore placed near the furnace and through the top of this were projected three gas muffle burners, about six inches apart. The box was covered with several sheets of asbestos. The mould, clamped tightly together was set on blocks of graphite directly over the burners and surrounded by fire bricks and sheets of asbestos. The whole apparatus was tilted so that the mould was about ten degrees from the horizontal (see Fig. 3). The mould was heated to bright redness for the higher melting alloys while a dull red was sufficient for those melting at lower temperatures.

As is well known, one of the greatest difficulties in the melting of brass is the loss of zinc by oxidation. This oxidation was cut down by the use of powdered charcoal, sodium chloride,<sup>1</sup> and by passing illuminating gas directly into the crucible, through an iron cover placed over it. These pre-

<sup>1</sup> The Brass World, Sept., 1912, page 307.

cautions were sufficient to reduce the oxidation of the zinc to a minimum, while being heated in the furnace, but the moment the crucible was uncovered for pouring, considerable oxidation occurred even before the melt could be transferred to the mould. In spite of the rapidity of pouring and the use of the centrifugal sprew, it was found that when the metal was poured from the top of the crucible small pieces of oxide were carried into the test section; and, being insoluble in the melt, they rendered the casting worthless. This difficulty was overcome by pouring from the bottom of the crucible, as in the Thermit process, thus avoiding the oxides almost entirely. A hole  $\frac{3}{8}$  inch in diameter was bored in the bottom of the crucible and close to the inner edge. A graphite plug extending to the top of the crucible was fitted into the hole. A heavy arm of wood  $2 \times 3$  inches  $\times$  4 feet was screwed in a slightly slanting position to a nearby permanent support, (see Fig. 3) so as to extend just over the mouth of the mould, and a few inches above it. On the end of this arm was screwed a heavy iron plate, semi-circular in form with the lower edge projecting inward. The crucible could thus be taken from the furnace and held by means of tongs on this semi-circular support. By means of a previously made gauge-mark on the outside of crucible, the hole in the bottom could easily be placed directly over the mouth of the mould. While holding it in this position the plug could be pulled from the top, thereby allowing the metal to be poured in a continuous stream. Without this support the drawing of the plug usually jarred the crucible so much that a continuous stream could not be sent into the mould, without which it is almost impossible to get good castings with the type of mould used here. In order that the mould, after having been removed, could be placed in the proper position with respect to the crucible, two adjustable iron guards were fastened to the arm just back of the semi-circular support. One of these was arranged so as to press against the end of the mould and the other against the side. By placing the mouth of the mould directly

under the outlet of the crucible and adjusting the two guards, the mould could be removed and always replaced in the same position with respect to the crucible. However, by this method of pouring, the excess metal could not be retained in the crucible. So an asbestos trough was placed under the front end of the crucible and when the mould was filled, the remaining metal was carried into a tank of water. After each pouring, the zinc oxide formed during the pouring was scraped from the inside of the crucible before placing another charge in it.

Fig. 3 shows the general arrangement of the apparatus. A is the mould resting upon graphite blocks and held in place by the movable guards E and F. A section of the crucible

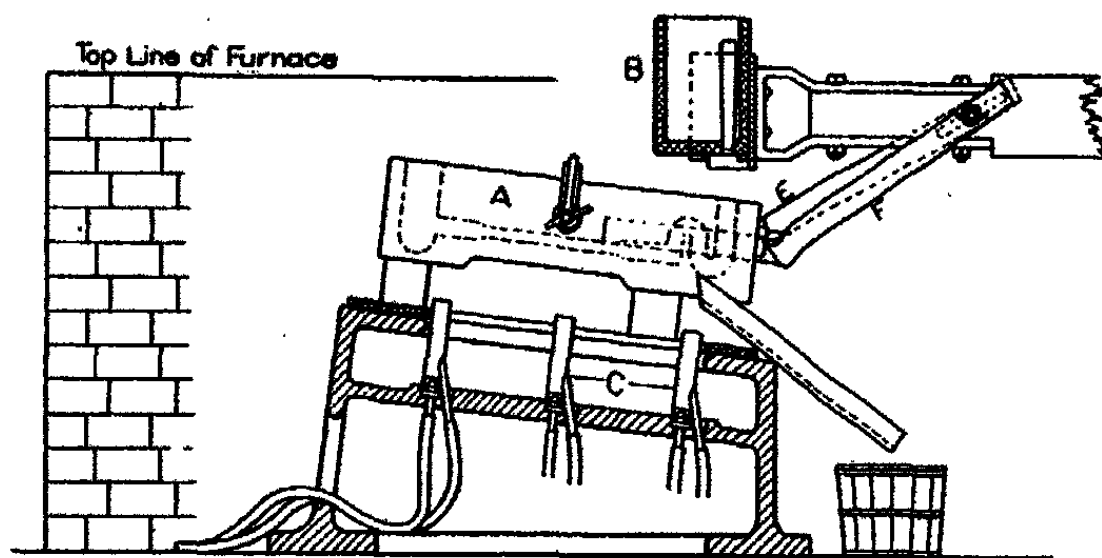

Fig. 3

B, is shown with the hole for pouring and the plug directly over the mouth of the mould. C is the frame holding the muffle burners.

After the pouring, the mould was opened quickly and the casting immediately quenched in water. As most of the castings were quenched from red heat, it was necessary to guard against bending the test-piece while removing it from the mould, especially as the metal forming the spew and riser was very much heavier than the rod itself. Hence, for quenching, a slab of graphite to which was fastened a

stationary upright strip of iron, was placed across the top of the can of water. One-half of the mould was removed, and the half containing the casting was placed in an almost vertical position on this graphite slab, being supported against the iron strip. Then by means of a suitable hook, the casting could be removed from the mould and lowered vertically into the water.

The materials used for making the test-pieces were electrolytic copper of 99.98 percent purity and pure Bertha spelter, thus avoiding the influence of even minute quantities of foreign metals. The copper which is sold in twenty-pound pigs, was sawed into two pieces and these pieces were melted in the electric furnace and recast into small ingots, or granulated by pouring into water. For this melting the largest of the crucibles previously described was packed in the furnace and the one of medium size used for the melting. The zinc, which is sold in slabs, was broken into small pieces. To avoid loss of zinc by volatilization in the subsequent work, at the beginning of this set of experiments a large quantity of 50 : 50 brass was made as a basis for starting. To this, copper could then be added to make any desired composition.<sup>1</sup> The excess metal from pouring and the broken test-pieces were melted over and over. In every case, in which pure copper was used, it was melted first and then the lower melting alloy, or zinc, was added.

A careful study of the pouring temperatures was made. A base metal thermocouple supplied by The Hoskins Manufacturing Company of Detroit, was used for these measurements. This couple may be placed directly in the melt. It was rather satisfactory, but cannot be considered an entire success. After using it eight or ten times it would generally break, because of corrosion, just back of the twisted ends. As nearly as could be ascertained, this corrosion occurred at that part of the couple which was at the surface of the melt or above it, rather than at the part in the melt. The tempera-

<sup>1</sup> Desch: Metallography, page 108.

tures were taken just as soon as the metal reached the molten state, and pouring was usually done very soon after this to avoid overheating by holding the metal too long in the furnace.

#### Testing

All of the tests were made on a 10,000-pound Olsen hand machine.

After sawing the metal formed by the spew and the riser from the test-piece, it was tested as cast, except that the small fins formed along the test rod by the burning out of the graphite around the casting were filed away and the center of the piece was filed very slightly, to ensure the locality of the break.

The diameters of the test-pieces were taken at the slightly reduced areas by means of a micrometer caliper reading to thousandths of an inch. As the pieces were not perfectly circular three diameters were taken, and the average used for computing the strengths. The records of elongation were taken between five-inch lengths on the test-piece, by means of fine-pointed dividers, and read on a steel scale divided into hundredths of an inch.

The broken pieces were always examined carefully, and the general appearance, together with the character of the fracture, as seen under a hand lens, was carefully recorded. Much valuable knowledge of the interior of the pieces was thus gained. In addition, three diameters of the fractured ends were taken, from the average of which, were computed tensile strengths, based on the reduced areas. Of course, the values thus obtained are not perfectly accurate owing to the difficulty of taking accurate measurements on such broken ends. But, allowing for the error, they give us some interesting data.

In determining the value of a piece, after making the test, it was considered good if it had the proper color and homogeneity, and contained no large holes. It was called good even if it contained one or two pinholes of occluded gas.

On account of the heavy loss of zinc by volatilization

during the melting, it was impossible to prepare test-pieces of a given composition. This could be done to within 1 percent in the compositions above 65-70 percent copper, but in those of a higher zinc content, it was difficult to come quite as close. As a result, each piece had to be analyzed. Hence, the nature of the fracture determined whether a piece should be analyzed or not. And, in addition to the good pieces, only those others whose composition it seemed desirable to have, were analyzed. Copper was determined electrolytically and the zinc obtained by difference.

#### Results

The results of this research are given in the accompanying tables, and are presented graphically by means of curve diagrams. It was thought desirable not to present all the data taken, as this would be too cumbersome.

Table I gives a complete summary of the final results. The first column shows the copper composition of each alloy obtained by analysis. In the second column are recorded the temperatures as taken just before pouring. The third column shows the freezing temperatures for the corresponding compositions, taken directly from the freezing curve (Fig. 1). In the fourth column are tabulated the differences between the pouring temperatures and the corresponding freezing temperatures. The next column shows the ultimate tensile strengths in pounds per square inch, while in the following column are given the ultimate strengths based upon the reduced areas of the broken ends. Following this, we have the ductilities, based on five-inch lengths on the test-pieces, and in the last column the good pieces are designated by "G" and the faulty ones by "B."

Table II gives a list of the "good" pieces of the regular series.

No work was done on heat treatment.

The tensile strength curve is shown in Fig. 4. The abscissas are percentages of copper, while the ordinates are pounds per square inch. For comparison, the values of



TABLE I—Summary of tests

Percent copper	Pouring temperature	Freezing temperature	Difference	Tensile strength		Ductility	
				Original section	Fractured sections		
100	1160	1080	78	14419	—	17.2	B
—	1170	1082	88	22618	—	19.3	G
95.5	—	—	—	30053	—	17.5	G
94.0	—	—	—	25243	—	17.5	B
90.6	—	—	—	29320	85646	28.8	G
90.5	1230?	1050	180	27660	60151	—	G
90.3	—	—	—	31392	71401	30.8	G
88.5	1140	1040	100	32181	64014	24.8	G
88.2	—	—	—	29443	85189	28.0	G
87.6	1150	1040	110	30690	68461	24.4	G
86.0	—	—	—	32000	—	—	B
86.0	—	—	—	28200	—	12.5	B
85.6	—	—	—	30890	79100	24.8	G
81.3	1120	1015	105	32293	67047	22.8	B
81.3	—	—	—	32634	65930	30.8	G
81.2	—	—	—	33590	95875	—	G
80.0	—	—	—	26137	—	—	B
80.1	—	—	—	30574	—	—	G
80.5	1130	1000	130	30486	—	—	B
79.7	—	—	—	30900	57830	24.3	G
79.6	1140	1000	140	31899	64642	26.1	B
77.8	—	—	—	31199	65000	—	B
77.3	—	—	—	27560	54687	24.6	B
77.0	1210	985	225	27449	48789	24.9	B
76.1	1080	980	100	32323	51933	29.6	G
76.0	—	—	—	29100	—	—	B
75.3	1160	980	180	26311	45145	22.2	B
74.1	1220	970	250	31820	—	—	B
74.3	1200	970	230	32000	58300	—	B
73.3	1020	960	60	33955	65200	—	B
72.3	1090	960	130	31101	49563	—	G
72.0	—	—	—	24900	—	—	B
71.9	1100	960	140	34449	64600	31.4	G
70.9	1070	950	120	29138	41800	—	B
70.5	—	—	—	32300	—	—	B
70.5	—	—	—	19400	26748	11.2	B
70.3	—	—	—	26752	45368	—	G
70.2	1100	950	150	30528	—	—	G
70.2	—	—	—	28983	—	22.7	B
68.8	—	—	—	33090	48500	60.4	B
66.5	1030	920	110	34000	—	—	B
66.3	1030	920	110	36465	64262	35.6	G

TABLE I—(Continued)

Percent copper	Pouring temperature	Freezing temperature	Difference	Tensile strength Original section	Fractured sections	Ductility	
65.8	1100	915	185	35200	67500	29.1	G
65.8	1070	915	155	36701	75000	31.5	B
65.2	—	915	—	35800	—	34.1	G
64.5	1020	910	110	41359	87300	—	B
63.1	1030	900	130	46559	108000	—	G
62.7	1075	893	180	47457	82250	30.8	B
62.3	1050	890	160	47715	120500	36.2	G
62.3	1030	890	140	50917	86620	31.8	B
62.3	1020	890	130	52300	89730	34.8	G
61.4	950	890	60	53043	99509	29.8	G
61.1	1000	890	110	55555	101800	25.2	G
60.9	980	890	90	56355	127990	31.6	G
60.6	1060	890	170	50149	73799	25.2	B
60.5	940	890	50	56211	103230	24.1	G
60.3	1000	890	110	57409	97153	26.0	G
59.8	1080	890	90	58139	104166	20.4	G
59.4	—	—	—	55800	135621	38.0	G
59.0	1000	890	110	56147	80117	21.0	G
58.1	950	890	60	62909	81400	—	G
57.7	960	885	75	55971	67000	—	G
57.1	1000	885	115	66910	—	—	G
57.0	950	885	65	59454	71509	9.6	G
56.7	1050	885	165	69534	93421	—	G
56.4	1030	885	145	68806	95301	14.1	G
55.7	1010	885	125	63697	—	11.4	B
55.4	1050	885	165	71193	95515	14.8	G
55.0	950	885	65	59666	96728	17.0	B
54.9	1000	880	120	62119	76504	12.8	G
54.8	1050	880	170	62555	87643	12.0	G
54.8	950	880	70	57835	74510	9.8	B
54.1	1050	880	170	68181	94458	13.6	B
53.0	980	880	100	49900	60325	9.2	G
53.0	1050	880	170	66026	81311	—	G
53.0	1040	880	160	58349	—	—	B
52.0	—	—	—	42900	—	—	B
48.1	—	—	—	10080	—	—	B
48.5	—	—	—	14000	—	—	B
47.5	—	—	—	24531	—	—	G

TABLE II—"Good" pieces in regular series

Percent copper	Pouring temperature	Freezing temperature	Difference	Tensile strength Original section	Fractured sections	Ductility
100.0	1170	1082	88	22618	—	19.3
95.5	—	—	—	30053	—	17.5
90.6	—	—	—	29320	—	—
90.3	—	—	—	31392	71401	30.8
88.5	1140	1040	100	32181	64014	24.8
88.2	—	—	—	29443	85189	28.0
87.6	1150	1040	110	30690	68461	24.4
85.6	—	—	—	30890	79100	24.8
81.3	—	—	—	32634	65930	30.8
81.2	—	—	—	33590	95875	36.8
80.1	—	—	—	30574	—	—
79.7	—	—	—	30900	57830	24.3
76.1	1080	985	95	32323	57933	29.6
72.3	1090	960	130	31101	49563	—
71.9	1100	960	140	34449	64600	—
70.2	1100	950	150	30528	—	—
68.8	—	—	—	33090	48500	60.4
66.3	1030	920	110	36465	64262	35.6
65.8	1100	915	185	35200	67500	29.1
65.2	—	—	—	35800	—	34.1
63.1	1030	900	130	46559	108000	—
62.3	1020	890	130	52300	89730	34.8
62.3	1050	890	160	47715	102500	36.2
61.4	950	890	60	53045	99509	29.8
61.1	1000	890	110	55555	101800	25.2
60.9	980	890	90	56355	127990	31.6
60.5	940	890	50	56211	103230	24.1
60.3	1000	890	110	57409	97153	26.0
59.8	1080	890	190	58139	104166	20.4
59.4	—	—	—	55800	135621	38.0
59.0	1000	890	110	56147	80117	21.0
58.1	950	890	60	62909	81400	—
57.1	1000	885	115	66910	—	—
57.0	980	889	95	61754	63900	9.6
56.7	1050	885	165	69534	93421	—
56.5	1030	885	145	68806	95301	14.0
55.4	1050	885	165	71193	95515	14.8
54.9	1000	880	120	62119	76504	12.8
54.8	1050	880	170	62555	87643	12.0
53.0	1050	880	170	66026	81311	—
47.5	—	—	—	24531	—	—

Thurston and Mallet are also given on the same plate. There is a slight increase in the tenacity with the first addition of zinc, after which the values remain almost the same throughout the  $a$  field, increasing only about 5000 pounds per square inch over the range to about 66 percent copper. From that

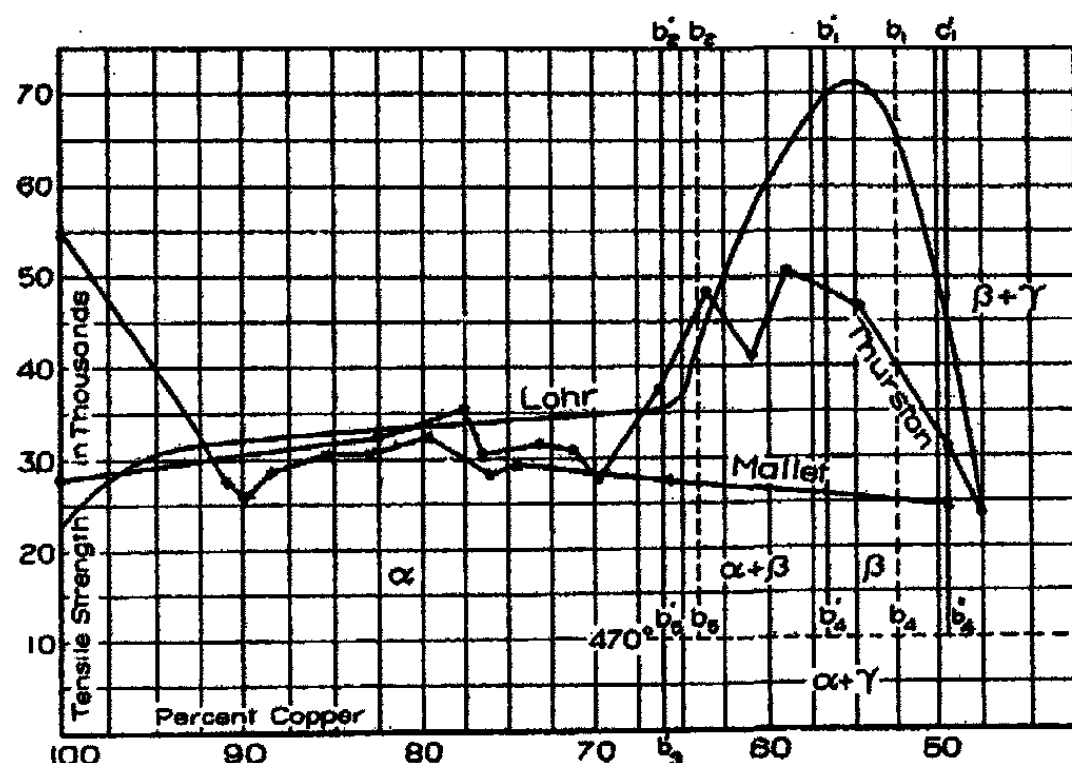

Fig. 4

point there is a very sudden increase, the values going up rapidly to a maximum at 55.4 percent copper. The values fall very gradually from that point to that of 53 percent copper, while a very sudden drop is noticed in the alloys containing from 53-47.5 percent copper. Beyond this no work was done, as these alloys are very brittle and not of very great practical use. Owing to the great number of castings made, values of close compositions were obtained, resulting in a very smooth curve.

Since the test-pieces used in this investigation were all quenched immediately after casting, it was predicted that the lines  $b_2b_3$ ,  $b_1b_4$  and  $c_1d_1$ , marking respectively the boundaries between the  $a$ ,  $a + \beta$  and pure  $\beta$  fields, would be somewhat changed from the positions which they occupy on the equilibrium diagram (Fig. 1). In order to determine the extent

of these changes, a series of specimens taken from the ends of various test-pieces were examined microscopically and photographed. The dendritic structure of the  $\alpha$  crystals referred to by Shepherd,<sup>1</sup> was seen very plainly in specimens containing 81.3, 74.6, 71.9, and 66.3 percent of copper. However, the 65.8 percent alloy showed small areas of  $\beta$  crystals scattered through the great mass of  $\alpha$  crystals. This shows that the field of pure  $\alpha$  ends at about 66 percent copper. Comparison with the diagram will show this position to be somewhat to the left of the line  $b_1b_2$ , as obtained under equilibrium conditions. In a similar manner, we find the line  $b_1b_2$  moved to the left. The 55.4 percent alloy was composed entirely of pure  $\beta$ , while the 57.1 percent alloy showed a considerable mixture of  $\alpha$  crystals, indicating very plainly that pure  $\beta$  extends almost to 57.0 percent copper. On the other hand, the position of the line  $c_1b_1$  was found to change somewhat to the right of that shown on the equilibrium diagram. The 53.0 percent alloy consisted entirely of pure  $\beta$ , whereas the one containing 47.5 percent copper was shown to consist of about three-fourths  $\beta$ , distributed through the  $\gamma$  metal. This indicates that pure  $\beta$  must cease to exist at about 49 or 50 percent copper. Remembering that the castings used in this work were quenched at about 700°–800°, and before equilibrium was reached, we can account very satisfactorily for the new positions of these boundary lines. In the several figures in this paper the positions of the boundary lines of the different phases as found here, are contrasted with their positions on the equilibrium diagram. The latter are represented by dotted lines, while the heavy lines show the boundaries obtained in this work.

If we compare the tensile strength curve with the positions of the boundary lines here established, we find a very close relationship. Throughout the  $\alpha$  field there is only a slight change in the tensile strengths. At about 66 percent copper, where the  $\beta$  crystals begin to appear, the strengths

<sup>1</sup> Jour. Phys. Chem., 8, 427 (1904).

begin to increase, and continue to increase throughout the range of the metal composed of  $\alpha + \beta$  crystals. The maximum strength is found to lie wholly in the  $\beta$  field. As we approach the  $\gamma$  field the strengths fall rapidly, until at 47.5 percent copper where the amount of  $\beta$  is small, the tenacity is only about 25,000 pounds per square inch.

Let us now compare the results of this paper with those of Mallet and Thurston. Mallet's strength of pure copper is hardly comparable here, as his test-pieces were prisms 0.25 inch square. It will be referred to later. His results between 90 and 75 percent copper agree well with Thurston's, but he seems to have neglected the section of greatest change in strengths, as his work includes no tests between 66 and 49 percent copper. Thurston's curve is of the same general form as that obtained by the writer, but much more irregular. For compositions around 70 percent copper, and for those containing less than 63 percent copper his values are considerably lower. His maximum is at about 58 percent copper.

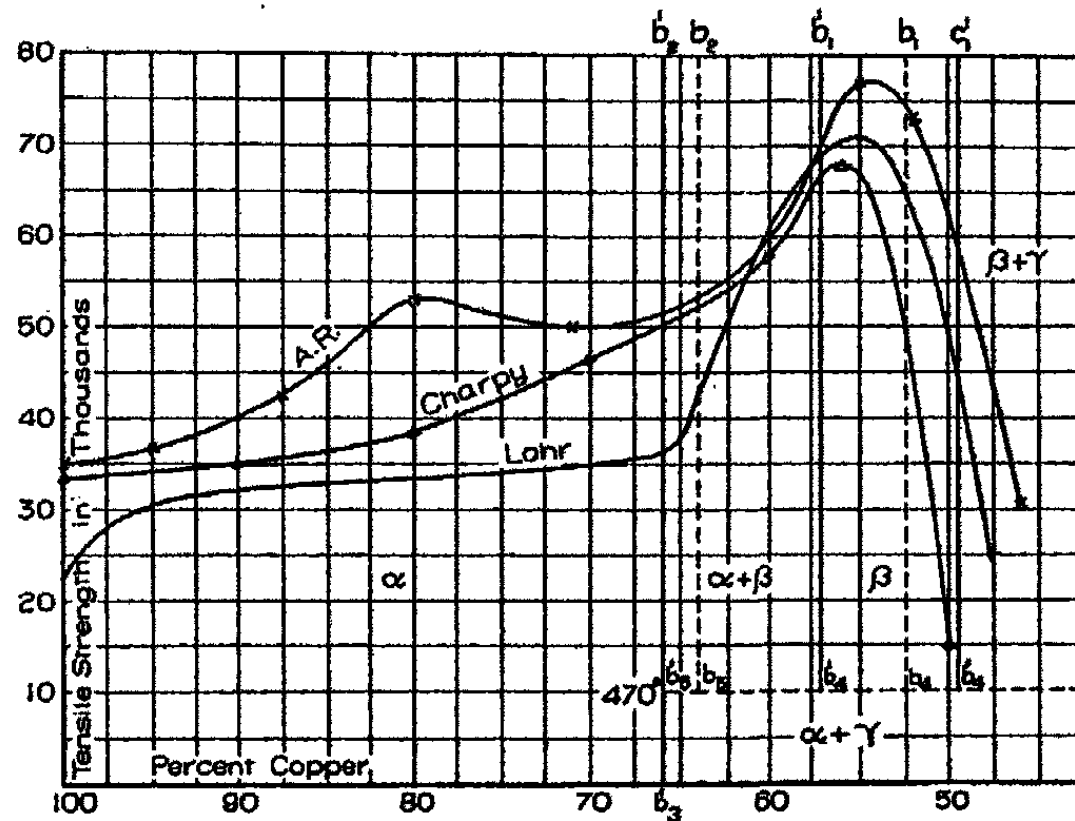

Fig. 5

In Fig. 5, comparison has been made with the work of

Charpy on annealed brasses, and with that of the Alloys Research Committee<sup>1</sup> on worked rods. As would be expected, the tensile strengths of worked metal are greater than those of cast metal throughout the greater part of the series. This is due, of course, to the decrease in the grain size brought about by working the metal. On the other hand, for annealed brasses one would predict tensile strengths lower than those given by castings without heat treatment. This decrease in strength should result from larger crystals due to annealing. But Charpy's results show greater strengths over the whole of the  $\alpha$  field and a part of the  $\alpha + \beta$  fields. This must be very largely due, therefore, to the small size of the test-pieces which he used. These pieces were 5 mm in diameter, and consequently on quenching, would cool very rapidly, thereby reducing the grain size, and giving high tensile strengths. The presence of traces of other metals may also have had an effect in increasing the strengths.

The small size of the test-pieces, and therefore the small grain size, will also probably account for the abnormally high value for cast copper obtained by Mallet, as the prisms used in his tests were 0.25 inch square.

In connection with this it is also interesting to notice the very high tensile strengths, based on the reduced areas as shown in Table I. In the region of 60 percent copper these strengths are considerably over 100,000 pounds per square inch, in one case (alloy 59.4 percent copper) attaining a value of 137,000 pounds per square inch. This value is 40 percent higher than the maximum obtained by the Alloys Research Committee with worked metal. As this is practically the strength of the alloy at the time of break, it is in reality the breaking strength of "drawn" brass and shows the ultimate possibility of obtaining such values for metal thus worked. In view of this fact, and noting that extruded zinc<sup>2</sup> with a tensile strength of 23,000 pounds per square inch,

<sup>1</sup> Proceedings of Mech. Engineers, Parts 1 and 2, 31 (1897).

<sup>2</sup> Jour. Franklin Inst., 172, 558 (1911).

and electrolytic copper<sup>1</sup> of 68,000 pounds per square inch have recently been obtained, some interesting possibilities for future high tensile strengths are suggested.

In casting these alloys, little trouble was experienced in obtaining good homogeneous test pieces above 80 percent copper, but from 65–80 percent copper it was exceedingly difficult. The greatest difficulty was that of porosity.

Dozens of castings were made, perfect in external appearance, only to show upon breaking, a thin solid homogeneous outer crust or shell, within which was an area of porosity, varying according to the conditions under which the metal was melted and poured. The melting was largely done under illuminating gas which, for the purpose of preventing oxidation of the zinc, was led through a perforated cover into the top of the crucible. On this account, it was thought that perhaps the molten metal had absorbed gases, which it could not force out when quenched immediately after casting. Therefore, experiments were made, keeping all other conditions the same, in which granulated charcoal, sodium chloride, and illuminating gas, respectively, were used as a protection for the melt. The gas was used in the ordinary manner—that of leading it into the top of the crucible. And in a few cases it was led through a carbon tube directly into the melt, and distributed through it by stirring with the tube carrying the gas. Under each of these conditions, several pieces were quenched immediately after they were removed from the mould; others were quenched after they had been allowed to remain in the air in the open mould for about three minutes; and still others were allowed to cool in the air. In almost every case the pieces allowed to cool in the air showed, upon breaking, good solid homogeneous metal, free from porosity. There were, however, a few instances in which slight traces of porosity could be noted even in these. But while the porosity was thus almost entirely prevented, the crystallization was allowed to take

---

<sup>1</sup> Bennett: *Jour. Phys. Chem.*, 16, 294 (1912).



place slowly, thus giving large crystals and a consequent reduction in strength. In every case the metal was porous in the pieces quenched at once. This was more marked in those pieces in which gas had been led into the melt. The best results were obtained in the cases in which quenching was done about three minutes after the metal was poured and the mould opened. Even when gas was used, solid homogeneous metal was obtained, when the pieces were quenched under these conditions.

In every instance, when the broken ends showed porosity, a solid shell of metal was noticed on the outside of the piece, and also in many instances there was a distinct break, or pipe, in the center. In view of these experiments, a possible explanation is that the dissolved gases have time to escape when the metal is allowed to cool entirely in the air, or is allowed to remain in the air for a few minutes before quenching, whereas when the pieces are quenched at once the sudden cooling causes a thin shell of metal to form on the outside, thus preventing the gases in the interior from escaping.

As we pass from 65 percent copper toward a lesser copper content, a very different kind of metal is noted. This is the range of the mixture of  $\alpha$  and  $\beta$  crystals. This was decidedly the easiest brass to cast, as almost every casting was solid and gave a good break. There was, however, a slight tendency toward the formation of holes lined with a bright yellow covering; but these were few in number. The fractures were mostly V shaped or oblique to the main axis of the piece. From 60-63 percent copper there was noticed quite a tendency to "neck." From 57 percent copper over the range of the  $\beta$  field we find a very hard metal, with little ductility. In spite of the short time for crystal growth, the crystal structure was large as revealed by the ragged, irregular fractures. Below 50 percent copper the crystalline structure was pronounced and very well defined.

The ductility curve is shown in Fig. 6. This rises

gradually with the addition of zinc and attains a maximum<sup>1</sup> at about 65 percent copper. It drops very suddenly at about 60 and then falls off gradually almost to zero at 47.5 percent copper. The maximum here shown differs somewhat from that obtained by other investigators, as both Thurston with castings and Charpy with annealed brasses found the maximum ductility to be at about 70 percent copper. This change in the maximum is evidently due to the method of cooling employed in this work. Under equilibrium conditions, as seen from the curves of the investigators mentioned above,

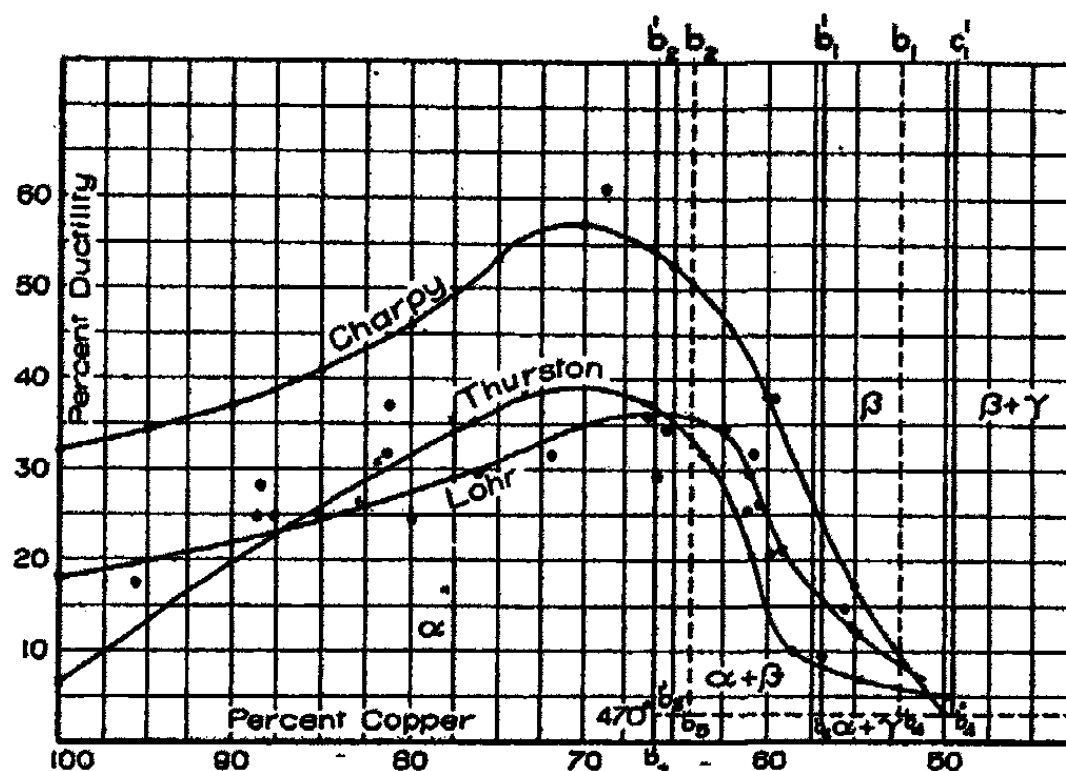

Fig. 6

the maximum falls just within the limits of pure  $a$ . Beyond that, the  $a + \beta$  crystals would break down into  $a + \gamma$  at the lower temperatures. The introduction of  $\gamma$  might possibly result in brittleness and decreased ductility, although this is not certain. If the  $\gamma$  metal is distributed through the  $a$  in a highly agglomerated condition, it undoubtedly would decrease the strength, whereas there is

<sup>1</sup> One 68.8 percent brass gave the remarkable elongation of 60.4 percent., but this could not be duplicated.

some question as to the effect of very finely divided  $\gamma$  distributed through the  $a$  metal. On the other hand, by the method of rapid cooling employed here, it is quite likely that only sufficient  $\beta$  crystals were carried over into  $a$  to increase the ductility and thus to throw the maximum to about 66 percent copper. This seems quite probable in view of the microscopic results previously mentioned. Here it was shown that  $\beta$  began to appear at about 66 percent copper. Pure  $\beta$  is very low in ductility but it appears that a mixture of  $a + \beta$ , with a preponderance of  $a$ , gives the highest ductility, when cooled quickly after casting.

The effect of the temperatures of pouring upon the strength of the brasses may best be noted by an inspection of Table II. A great majority of the "good" pieces were poured at temperatures somewhere between  $100^{\circ}$  and  $200^{\circ}$  above the liquidus. In a few cases, with the temperatures less than  $100^{\circ}$  above the liquidus, good castings were obtained, but generally the metal was too viscous to be handled easily, and to fill the mould properly. However, it was absolutely impossible to obtain good test-pieces with the pouring temperature more than  $200^{\circ}$  above the liquidus. In every case the castings were of good external appearance, but contained numerous black spots of porous material presumably copper oxide. This was more noticeable as the copper content increased. In many cases, those pieces cast from temperatures more than  $200^{\circ}$  above the liquidus showed less than a fourth of the strength which their compositions should have given.

It was impossible to limit the pouring temperatures to a closer range than  $100^{\circ}$ , as it will be noticed by referring to Column 4 of Table II, that frequently, castings of about the same compositions gave practically the same strengths, with temperatures as much as  $50^{\circ}$  apart.

In general, then, it may be said that brasses with the highest strengths can be obtained by having the temperature of pouring within the range of  $100^{\circ}$  C to  $200^{\circ}$  C above the liquidus.

### Conclusions

The following conclusions may be drawn from the results of this work:

1. A study of the tensile strengths of the cast brasses containing 47.5–100 percent copper has been made.
2. The  $\alpha$  brasses give almost a constant value for the tensile strengths.
3. The maximum tensile strength occurs in the neighborhood of a 55 percent copper alloy, and its value is about 71,000 pounds per square inch.
4. The  $\beta$  alloys give the highest tensile strengths.
5. The maximum strength does not occur on a boundary curve.
6. The variations in the tensile strengths agree very closely with the constitution of the alloys, as proven by the microscopic study.
7. A tensile strength of 137,000 pounds per square inch, as taken from the fractured ends, has been obtained.
8. A maximum ductility of about 36 percent elongation has been obtained regularly. One piece, however, showed an elongation of 60.4 percent, but could not be duplicated.
9. It is possible to obtain a cast brass having an ultimate tensile strength of 71,000 pounds per square inch, and an ultimate elongation of 14.8 percent; or, a brass having an ultimate tensile strength of over 36,000 pounds per square inch and an ultimate elongation of 35.6 percent.
10. A method for continuous pouring of metal has been devised.
11. The effect of temperatures of pouring has been investigated.

This work was suggested by Professor Bancroft, and has been carried out under his direction. This opportunity is taken to thank him most heartily for his continual kindly interest in the work, and for the many helpful suggestions offered during its progress.

Thanks are also extended to Mr. C. A. Scharschu for

assistance both in the casting and in the metallographic part of the work, and to Mr. O. W. Boies for assistance in casting. And finally, thanks are extended to Professor Upton for some suggestions, and for the use of the testing laboratory of Sibley College.

*Cornell University,  
May, 1912*

## RECENT ADVANCES IN OUR KNOWLEDGE OF COLD LIGHT<sup>1</sup>

BY HERBERT E. IVES

No more fascinating field of research exists than that of light production by means other than high temperature. Both from the standpoint of scientific theory, and from the standpoint of practical light production, the opportunities for increasing and applying our knowledge are great. On the other hand, there is scarcely any branch of science in which adequate theories are so few or so unsatisfactory. The theory of light production by luminescent processes is thus in striking contrast to the Wien-Planck theory of temperature radiation.

The general characteristics of luminescence are, first, the low temperatures at which the light is produced, and second, the discontinuous spectra of such light. Conforming to these characteristics are the luminous phenomena produced by a variety of causes, in different media, and under various conditions. The usual classification is into fluorescence and phosphorescence, produced by light, cathode rays, X-rays, etc.; electro-luminescence, produced by the passage of an electric current; tribo-luminescence, brought about by friction; thermo-luminescence, caused by gentle heating; and chemi-luminescence, accompanying chemical reactions, and including the interesting cases of light production by living organisms.

A very large amount of experimental work has accumulated along these lines, and no more than a brief mention of the more striking researches, with their theoretical bearing, can be here attempted.

*Fluorescence.*—By fluorescence is commonly understood the production of light possessing the characteristics of lumin-

<sup>1</sup> A paper read before the Eighth International Congress of Applied Chemistry in New York, September, 1912.

escence while under the influence of the exciting force, which latter may be light, cathode rays, or other form of radiant energy. Besides the general characteristics of luminescence above noted, fluorescent light has been thought to conform to Stokes' law, which states that the emitted light is always of greater wave length than the exciting.

Among the most important recent experimental work on fluorescence must be ranked that of Wood, on sodium and other metallic vapors. By the use of improved technique, and of higher spectroscopic resolving power, the fluorescent spectrum of sodium vapor was found, when white light is employed as excitation, to be of a delicate banded structure. When, however, monochromatic excitation is used, there results not a banded but a line fluorescent spectrum. As the wave length of the exciting light is changed, different sets of line spectra appear, each forming a regular series. In these series, Stokes' law is not observed, for by exciting any one line of a series by resonance all the other lines respond, indicating that the various monochromatic radiations are given out by a common system. Much information as to the nature of the radiating systems will undoubtedly follow from this work and from that now being carried on in continuation of it. Among the latter researches may be noted the remarkable experiment of changing the line resonance spectrum of iodine vapor into a band spectrum (resembling that excited by white light) by means of the presence of helium gas.

In a somewhat different field are the interesting fluorescent spectra found by Goldstein in the aromatic compounds, which exhibit peculiar changes in intensity and character with variations in the excitation and physical conditions.

Nichols and Merritt in an extensive series of studies have determined the distribution of intensity in the spectra of various fluorescent substances, and the effects of temperature thereon. Their latest work, on the distribution of intensity among the narrow bands in the spectra of the uranyl

compounds, shows that the envelope of these bands has a shape similar to that of the intensity distribution in the broad, single emission bands of many other fluorescent substances, such as the alkaline earth sulphides. Taken in conjunction with the fact that these bands are much sharper at low temperatures (Becquerel) and broaden at high temperatures, there is here evidence for the complex character of the rather common diffuse emission bands given by fluorescent and phosphorescent substances.

The chief theories of fluorescence consider it in relation to phosphorescence and will be treated here under that head.

*Phosphorescence.*—By phosphorescence is commonly understood a luminescence which persists after the removal of the excitation. Frequently it is considered as differing from fluorescence in this respect alone and the one is held to graduate insensibly into the other. Certain substances which, on ordinary examination, appear to be merely fluorescent are found on examination with the phosphoroscope to exhibit a phosphorescence of very short duration. Often the duration of this phosphorescence may be increased by lowering the temperature.

Attention must here be directed chiefly to two investigators and their theories, and to the work which has been done by them or inspired by them—Kowalski and Lenard. The theory advanced by Kowalski calls for two systems of electron groupings, called electronogens and luminophors. The first expel electrons under the influence of light; the second have an internal energy closely approaching the critical value at which explosive action takes place in accordance with the ideas of J. J. Thomson. Under the influence of light the electronogens expel electrons which carry additional energy to the luminophors, destroy their equilibrium and so cause disintegration and emission of light.

Recent experimental work by Kowalski on organic compounds at low temperatures has resulted in the separation of two processes, one of which decays with great rapidity on the



removal of the excitation, the other much more slowly. The two processes have different spectra. These results are apparently more in accord with the theory of Lenard, which follows:

Lenard has directed his study to the alkaline earth sulphides, of which Balmain's paint (calcium sulphide) and sidot blende (zinc sulphide) are examples. Through an exhaustive investigation in conjunction with Klatt, he has definitely determined the composition of these sulphides. The constitution of a "phosphor" is three-fold: first, an active metal, present in very small quantity; second, an alkaline earth sulphide; third, a flux. Having reduced the preparation of the phosphors to a science, Lenard has conducted noteworthy investigations on the properties and behavior of these substances under different excitation and conditions. Each phosphorescent spectral band has been found to have three phases—a lower momentary phase, at low temperatures; a permanent phase; and an upper temporary phase at high temperatures. The characteristics of the permanent phase are that, first, it gives lasting phosphorescence, and second, it is caused chiefly through excitation by light at several isolated spectral regions. The temporary phases are excited by a large range of short wave-length radiation, and are of excessively short duration of phosphorescence. The various bands have their permanent phases at different temperatures.

To explain these phenomena, Lenard has formulated a very striking theory. He considers the action of light to be the photo-electric action, that is, the tearing off of electrons from the active metal by the resonance action of light. These electrons are then captured by the surrounding sulphur atoms. Some are released at once, others are stored and only gradually returned. The (photo-electric) electrons on their return, vibrating with ever-decreasing amplitude and period, set in motion, by resonance, at a certain period in their decreasing swing, another set of electrons in the metal atoms, the latter called "emission electrons." It is the vibrations of the emis-

sion electrons that cause the visible light, of greater wave length than the exciting (Stokes' law). The extinguishing action of infra-red radiation is attributed to the fact that the free period of the captured metal electrons is such as to respond to the longer wave excitation. The complex molecule is set into vibration and gives up its metal electrons sooner than it otherwise would.

Some deductions from this theory have met with strong confirmation. It has been found, for instance, that the relative wave lengths of the permanent excitation regions for the same active metal may be derived from the dielectric constant of the alkaline earth sulphide. The theory calls as well for a number of bands not to exceed the number of valence electrons, that is, four, and although Pauli has recently found both ultra-violet and infra-red phosphorescent bands this number is not exceeded.

An interesting contribution to this theory has recently been made by Pohl. Lindemann had discovered that the wave length at which metals respond to the selective photo-electric effect may be calculated from the atomic volume and valence of the metal, on the assumption of a planetary system obeying Kepler's laws. Pohl calls attention to the fact that the wave lengths which excite the permanent phase of phosphorescence are in the ratio to each other given by Lindemann's relationship, in which the successive valences 4, 3 and 2, are substituted, thus supporting Lenard's view that we have here a case of the selective photo-electric effect.

*Electro-luminescence.*—The production of light by the passage of an electric current through a rarefied gas belongs in the category of luminescent phenomena, although the chief study has been from the electrical rather than the light standpoint. The past few years have, however, marked the commercial development of electro-luminescent devices, prominent among which are the Moore tubes, containing either carbon dioxide (white light) or nitrogen (yellow light). Lately, tubes of neon have been employed, noteworthy because of the

low cathode drop and the large portion of the emitted energy which lies in the visible spectrum.

*Chemi-luminescence.*—That light is an occasional accompaniment of chemical action, even at low temperatures, has long been known. Trautz, in a remarkably exhaustive study, has recorded some hundreds of cases of chemi-luminescence in its various forms of crystallo, tribo, and purely combination luminescence. No generalizations are possible at present beyond the observation that velocity of reaction and intensity of luminescence are approximately proportional. Some of the more intense of these reactions, such as that of pyrogallol and hydrogen peroxide, have been the subject of special investigation, but in all cases the amount of light produced was very small and difficult of study.

*Organic-luminescence.*—More and more attention is being devoted to the study of organic luminescence, whether of bacteria, marine organisms, or the luminous worms and flying insects. In these nature has solved the problem of light production in a manner different from that so far achieved by man. While usually the total light emitted is small, the intrinsic brilliancy is not so small as to make a similar light useless to man could he copy its mode of production.

Perhaps the most significant work done of late has been on the fire-fly. On the physical side, work by Ives and Coblenz has shown the spectrum of the emitted light to consist of a narrow band in the visible region, unaccompanied by any emission in all the ultra-violet and infra-red which could be studied by photography or phosphor photography, and with strong evidence that such invisible radiation cannot exist. Nor does the radiation possess any of the characteristics of true phosphorescence, such as dependence on light for excitation, or susceptibility to extinction by infra-red.

Interesting work by Kastle and McDermot on the chemical side has shown that the light-giving power of the insects is affected by many chemical reagents in a marked manner. They find the necessary conditions for the production of light

to be the presence of oxygen and water. Perhaps the most important result of their work has been the discovery that the dry powdered abdominal material of the insects will give out light when moistened, for as much as two years after the insect is dead, proving the emission of light to be a chemical phenomenon not dependent on life.

THE DIRECT PRODUCTION OF POSITIVES IN THE  
CAMERA BY MEANS OF THIOUREA AND  
ITS COMPOUNDS<sup>1</sup>

BY FRANCIS C. FRARY, RALPH W. MITCHELL AND RUSSELL E.  
BAKER

The increasing use of transparent positives in photographic processes inspired us to begin the study of methods for their direct production in the camera. It was hoped that such a process could be developed as would make it possible to produce lantern-slides, transparencies, and positives for use in the Askau process, without first making negatives. It was also hoped that the process would enable us to shorten the manipulation in the Lumière Autochrome and similar processes in color-photography. This work was begun nearly two years ago by Messrs. Frary and Baker, and was continued during the past year by Messrs. Frary and Mitchell.

Waterhouse<sup>2</sup> first described the use of thiourea in the direct production of positives, and recommended the use of the double salt, tetra-thiourea-ammonium bromide. His work seems to have attracted little attention, however, and apparently the results obtained with thiourea by others<sup>3</sup> were unsatisfactory. Recently Perley<sup>4</sup> has worked on this method, apparently obtaining more satisfactory results, using a hydrochinon developer instead of the eikonogen developer recommended by Waterhouse. But his directions are not very explicit, all his work was done on lantern-slide plates, which are quite different from ordinary plates, and we found that attempts to make positives according to his di-

<sup>1</sup> A paper read before the Eighth International Congress of Applied Chemistry in New York, September, 1912.

<sup>2</sup> Eder: *Jahrbuch für Photographie*, 16, 170 (1892).

<sup>3</sup> Nipher: *Trans. Acad. Sci. St. Louis*, 10, 210 (1900). Quoted in *Jour. Phys. Chem.*, 13, 237 (1909).

<sup>4</sup> *Jour. Phys. Chem.*, 13, 649 (1909).

reactions were seldom successful, and then only to a limited extent.

Working according to his directions, and using ordinary plates, we found it very hard to get results at all concordant, when all the conditions appeared to be the same. Using thiourea as he recommended we obtained fair positives, fogged plates, and hybrids, all under the same conditions of exposure, strength of developer, and time of development. It appeared that there was another factor capable of exercising a great influence, and this was found to be the temperature of the developer.

We have made about 600 plates in all by this process, and find that the predominant factors in the control of the results are: (1) brand of plate, (2) proportion of thiourea or its salts, (3) developing agent, (4) proportion of alkali, (5) proportion of restrainer, (6) character of thiourea salt used, (7) temperature of developer, (8) method of applying the thiourea compound. For uniformity, most of our plates have been made by printing under a lantern-slide at a distance of  $1\frac{1}{2}$  meters from a standard candle, the apparatus being set up in the dark room, and the candle thoroughly protected from draughts of air.

We find that the developer which gives the best results depends quite largely on the brand of plate used. This is not wholly a matter of the relative speed of the different plates, but seems to depend on the composition of the emulsion. Best results are obtained with plates of only moderate speed, such as the Cramer Banner X or the Seed 26. Most of our work has been done on the Cramer Banner X plate; after working out the effect of variations of the conditions on this plate, other plates were used for comparison. We have used Seed 26, 27, 30, process, and lantern-slide plates, Vulcan plates, Lumière Blue Label, and Lumière Sigma plates. In some cases the developer had to be modified to get the best results.

When the thiourea was used as a separate bath before

development, as recommended by Perley, it was used in a 1 : 1000 solution. When mixed with the developer, the same strength was used, in proportions varying from 30 to 40 parts per 100 parts of developer. Equal parts of the two solutions seem to give the best results; less thiourea has too great a tendency to give hybrids, and more produces excessive fog.

We find that different developing agents have different effects. The hydrochinon formula recommended by Perley (Sol. A : water 100, sodium sulphite (dry) 12.6, hydrochinon 2.1 gm.; Sol. B : water 100, sodium carbonate<sup>1</sup> (dry) 25.2 gm.) was the one which seemed to work best, and was used in most of the experiments. Satisfactory positives were also obtained with an adurol developer containing a rather large amount of alkali, but dianol and amidol were unsatisfactory. The effect of metol is very peculiar. A small amount of it added to the regular hydrochinon developer increases very much the density of the negative image which develops first, but acts as restrainer for the positive image. Hybrids generally result, although by decreasing the exposure very much and developing for a very short time, some rather poor positives could be obtained.

In general, the more alkaline the developer, the stronger the positive and the weaker the negative image obtained. The effect of the thiourea compounds seems to be dependent very largely on the presence of a large amount of alkali. With some plates (Seed Process, Lumière Blue Label, and Vulcan) the amount of carbonate in the developer above mentioned, which was excellent for the Cramer Banner X, must be considerably increased to get the best results. With Seed Lantern Slide Plates, the best results were obtained by reducing the sulphite and diluting the developer. With adurol the amount of carbonate required was four times that recommended by the manufacturers for development of the negative, or more than that required for the regular hydro-

<sup>1</sup> Mr. Perley has since informed me that this should be the crystalline salt, but we understood from his paper it was the anhydrous salt, and so used that.

chinon developer. Less than the proper amount of carbonate in any developer produces hybrids; more produces brown fog. The color of the resulting image is also dependent on the amount of carbonate in the developer, as well as the amount of sulphite, the developing agent, temperature, time of development, and brand of plate.

One strange thing about the process is the relatively large amounts of potassium bromide that are required to produce any restraining effect on the developer. It requires cubic centimeters where one would use drops in the ordinary development. As much as 7 cc of a 10 percent solution has been used in 100 cc of the mixed developer (1 part A, 1 part B, 2 parts thiourea solution), the only effect apparent being increased time required for development. If thiourea be used the addition of some bromide is advantageous, and the same is true of tetra-thiourea-ammonium bromide, but tetra-thiourea-ammonium chloride seems to work better without any restrainer. Acetone sulphite was a vigorous restrainer, but seemed to hold back the half-tones more than the shadows, tending to give harsh results. Potassium iodide was a very much more powerful restrainer than the bromide; the latter being easier to control was generally used when a restrainer was necessary.

The tetra-thiourea-ammonium bromide, recommended by Waterhouse, but apparently not tried by Perley or other investigators, was very much superior to the simple thiourea, giving clearer and better positives. Most of the work was done with it. The corresponding chloride salt, however, appears to be better still, and works without a restrainer. The iodide was not very satisfactory. All these salts were prepared according to the directions of Reynolds.<sup>1</sup> We would prefer the chloride, as far as our experience goes, although the bromide is a great improvement on the plain thiourea.

One of the most important factors in the process is the temperature of the developer, and this appears never to have

<sup>1</sup> Jour. Chem. Soc., 59, 384 (1891).



been noticed by any one. Control of all the other factors failed to give us reproducible results until the temperature was considered. For the method recommended by Perley (bathing in thiourea solution, with subsequent development) the best results were obtained at about 24°, much lower temperatures (18 to 20° C) giving hybrids, while higher temperatures (28 to 29°) gave very strong positives, with a heavy brown fog. This fog was troublesome at all times with this separate-bath process, unless the temperature was so low that the negative image came up so strongly as to make the result a hybrid. In the use of the thiourea or its compounds in the developer, as we prefer, the temperature may vary from 12 to 20° C, but temperatures of 15 to 18° C (60 to 65° F) seem to give the best results. Higher temperatures result in rapid development, with production of fog; low temperatures decrease the speed of development, and especially the development of the positive. At temperatures as low as 7° C the negative image could be developed, but no positive image was obtained below about 11°. This effect of temperature seems to be independent of the effect of all the other variables.

As indicated above, we find that we obtain much better results by mixing the solution of the thiourea compound with the developer in the proportion of 1 : 1 than by using it as a separate bath. In the latter case more trouble is found with fog, the results are more irregular, and tend to be spotted, the time of development and the difficulty of control are increased. Using the two solutions together, development is much the same as in the ordinary process, except that it takes less time.

The following procedure is recommended for the development of positives on the Cramer Banner X plate: The exposure is made in the ordinary way, and should be a little longer than for the production of a negative. Double the normal exposure will usually be about right. The hydrochinon developer recommended on a previous page is used,

mixing one part of A, one part of B, and two parts of a 1 : 1000 solution of either thiourea, tetra-thiourea-ammonium bromide or tetra-thiourea-ammonium chloride, preferably the latter. If thiourea is used, 0.5 cc of 10 per cent potassium bromide are added per 100 cc developer; if the ammonium bromide compound be used, 2 cc of the bromide solution per 100 cc developer, while if the ammonium-chloride compound is used no restrainer is needed.

Develop as usual, keeping temperature of developer between 15 and 18° C; the negative image first appears, then the plate appears to fog, and soon the positive image can be seen by transmitted light. Care must be taken not to over-develop, as the positive image will be quite strong. Rinse, fix, and wash as usual. If the negative image is too strong, it indicates over-exposure; the plate may be reduced slightly with the Farmer reducer. A foggy positive, with practically no negative indicates under-exposure, if the temperature of the developer has been kept within the proper limits. Development is rapid, being usually complete within four minutes. The positive image is characterized by its color; with the above conditions it will be red, warm sepia, or purplish red. The negative image is black and very transparent.

For making lantern-slides, the exposure will, in general, be less than that required to make a negative under the same conditions, and the developer should be diluted with an equal volume of water. If, however, the subject to be reproduced be a line-drawing, full strength developer and normal exposure may be used, followed by slight reduction. This will give excellent contrast. In fact, the principal fault of the process from the viewpoint of the slide-maker is the large amount of contrast obtained; the range from high-light to shadow is as great as in a good negative, consequently the slides of scenes tend to be too heavy in the shadows. This defect is minimized if an ordinary plate is used instead of a lantern-slide plate.

Excellent positives have been obtained on films from an Eastman Film-pack. They were made with the regular

developer, using the tetra-thiourea-ammonium chloride. The gradation and density thus obtained were excellent, and the films would make good lantern-slides.

For Cramer Crown, Seed 26 and 27 plates the procedure recommended for the Cramer Banner X plate is satisfactory. For Seed process plates, 4 g anhydrous sodium carbonate should be added to each 150 cc of the normal developer above recommended, and for Lumière Blue Plates, 6 g carbonate per 150 cc developer. The latter brand of plate did not give us very satisfactory positives under any circumstances; we are inclined to believe that the lot which we used had been kept too long before we obtained them.

The process works well with the Lumière Autochrome plate, using the normal developer diluted with an equal amount of water, but the strong red color of the image spoils the color rendering, so until this color can be modified the process does not seem to be applicable to this plate. In the earlier part of our work, rather remarkable results were obtained with these plates, by bathing them for one minute in 1 : 1000 thiourea solution before developing, and using the regular metoquinone developer and reversing solution recommended by the manufacturers. Results obtained indicated that good plates could be obtained with about  $\frac{1}{6}$  of the exposure otherwise necessary. These plates were made in the laboratory, the strength of the light being controlled by observations with the Watkins Bee Meter. However, recent attempts to duplicate these results on short exposures out-of-doors have been unsuccessful.

#### **Summary and Conclusions**

The conditions for successfully carrying out the Waterhouse process of producing positives have been carefully studied and are given in detail. The most important of these is the temperature of the developer.

The double salts formed by thiourea with ammonium bromide and chloride work better than the thiourea itself. The amount of restrainer used varies with the salt used.

The character of the developing agent and the quantity of alkali in the developer play an important part in the process; a strongly alkaline hydrochinon developer is recommended and the thiourea solution should be mixed with this as needed for use.

The process gives positives of excellent detail, with about the gradation and density of a first-class negative. The exposure is relatively short, being about double that required for the production of a normal negative.

*University of Minnesota,  
Minneapolis*

## THE PRESENT CONDITION OF COLOR PHOTOGRAPHY<sup>1</sup>

BY HERBERT E. IVES

The past five years have been noteworthy in the history of photography as marking the appearance of processes of color photography which have, in the fullest sense, been practicable and have been used extensively by the professional and the amateur photographer. While there is yet to be seen the simply produced print on paper which, to the popular mind, can alone deserve the name of color photograph, still pictures are now tolerably common which need neither an instrument to render them visible, nor delicately arranged conditions of viewing. It must be said, however, that in correctness of color rendering, no advance has been made on the three-color reproductions shown by F. E. Ives twenty years ago in the Kromskop, nor over some of the most perfect examples of the Lippmann process of almost the same age. Recent developments have all been toward simpler or popularly more acceptable means of achieving the same result.

It will be most feasible to discuss progress in color photography after making a classification of the various methods into direct and indirect methods (the latter again may be arranged under various sub-heads, as is done below). Considering, now, direct methods of color photography, there is but one illustration—the Lippmann or interference process. Because of extreme delicacy of manipulation, and because it is subject to disturbing influences, it has been used successfully by very few. Some work, however, has been done with it comparatively recently. H. Lehmann, Cajal and H. E. Ives have made studies of modes of preparation of the sensitive film, of the action of the different developers, and by means of sections of the film, of the action of various types of light.

<sup>1</sup> A paper read before the Eighth International Congress of Applied Chemistry in New York, September, 1912.

These have, in the main, confirmed the beautiful scientific theory which underlies this method. The last named investigator, by using certain slow, clean-working developers, and by bleaching with mercuric oxide, has produced films containing hundreds of reflecting surfaces and possessing a resolving power sufficient to reproduce spectral colors with great purity. Lehmann has developed a special color screen for taking interference pictures, in which are three maxima of transmission whereby whites are produced by a set of laminae instead of by a diffuse deposit, which latter frequently possesses a single maximum of reflection, corresponding to the center of the sensitive region of the plate, or to green. Some substitutes have been proposed for the mercury mirror originated by Lippman, but no attempts to simplify the process in this way have encouraged many to use it. The interference process seems in fact fated to remain only a beautiful scientific demonstration.

Indirect processes of color photography are those in which the color is not produced in the picture by the action of light, but is added either by instrumental means or by colored media, such as dyes. These processes naturally fall into two classes: one, represented by the prismatic dispersion process, in which the actual spectral composition of the original color is copied; the other, those making use of the physiological characteristics of the eye, whereby colors may be reproduced subjectively by the objective mixture of others. The first processes are at present confined to several schemes originated by Lanchester and others, whereby the image of the object photographed is spread out into a large number of narrow adjacent spectra, by the combination of a prism with an opaque line grating. The positive from the negative thus obtained is then viewed through an instrument similar to the camera. The images of the narrow spectra act as templates, transmitting more or less of the spectral colors to the eye at different points on the image. Thus an exact reproduction of the acting light is obtained, and the colors are reproduced in such a manner that they appear correct to all observers no matter

what their peculiarities of color vision. The necessity for using a viewing instrument and of accurately adjusting the linear spectral images to their spectra are, of course, disadvantageous from the practical or commercial standpoint.

With these brief notices of direct color photography, and indirect by spectral analysis and synthesis, we come to those processes which have produced, by far, the most promising and practical results, namely, the color mixture processes, which practically reduce to various forms of the three-color process. The theory of three-color photography, first put into scientific form by Maxwell, and later developed by F. E. Ives, may be outlined as follows: By experiment on color mixture, it has been found that all colors of the spectrum may be reproduced as to hue (but not absolutely as to saturation) by mixtures of three spectral colors—a red, a green and a blue. According to the experimental work of Koenig, and the theory known as the Young-Helmholtz theory, the facts of color mixture may be represented by the assumption of three so-called primary color sensations, red, green and blue, none of which are present in full purity in the spectrum. It is, however, possible to select from the spectrum the three colors in which each of the three sensations are present with least admixture of the two others, or it is possible to select three colors which in their mixture introduce least degradation of purity, that is, least admixture of white (either on the whole or in colors considered most important). Having selected three primaries conforming to the latter requirement, it is possible to obtain color mixture curves, giving the mixing proportions of these selected primaries which shall reproduce the spectral colors. If, now, three negatives are made, in each of which the distribution of photographic action through the spectrum is as given by one of the mixture curves, then these three negatives, or the positives from these, when suitably viewed by the three primary colors, and combined, will reproduce to the eye the original object. It is thus seen that the theoretical requirement is for negatives taken through

screens in which all the spectral colors are transmitted in certain proportions which represent the color and luminosity values, and for the viewing of the resultant positive by three colors which are only narrow isolated portions of the spectrum. Any departure from this latter condition means the use of primaries which, in their mixtures, either introduce more than the minimum possible amount of white, or else restrict the hue range.

The practically exact attainment of the conditions just outlined was actually reached in three-color projection, and in instrumental synthesis in the Ives-Kromskop twenty years ago, and no more perfect results have since been achieved. Recent progress in three-color photography has been along the lines of simplification of procedure, often, however, made possible by some compromise with the theoretical requirements.

The most prominent three-color processes now are those known as "screen plate," of which the Lumière Autochrome, Dufay and Warner-Powrie are examples. Their common characteristics, from which the name is derived, are, first, a mosaic screen of the three taking color screens, second, the negative emulsion superposed on this screen, and, third, the necessary practice of reversing the negative, in order to secure a positive, which, lying as it does in intimate contact with the mosaic screens, owes its color to the light transmitted by the complex color screen. The color photograph is a transparency, and from the manner of its production is unique and incapable of simple copying. The same mosaic of color screens is used for viewing as for taking. This entails a compromise: the constituent colors are made less pure than they should be for viewing purposes, more pure than they should be for taking. That this compromise causes a loss in fidelity of color rendering is unquestionable. Photographs of certain pure colors, such as a spectral yellow, which reproduces as red, show this only too plainly. Still, as most colors in nature are far from pure, and as the eye is marvelously adaptable to changes of



color scale and saturation, this compromise is much less apparent in the results than might be expected. Beautiful color photographs, chiefly taken by the Lumière process, are now rather frequently to be seen.

The various screen plate processes differ in their mechanical details. In the Autochrome plate the components of the screen are dyed starch grains, mixed in proper proportion to produce a gray and then strewn on the plate. In most of the other processes various lines or other geometric patterns predominate, some made by ruling processes, others—notably the Warner-Powrie—made by gelatine bichromate printing and subsequent dyeing. An advantage of the linear elements in the Warner-Powrie Screen is that the negative may be used for making structureless positives by a process of parallax printing. The irregular structure of the Autochrome plate keeps more than a portion of the transmitted light from being available for contact printing on another plate, or on a bleach-out paper.

Another development of the three-color idea which has produced interesting results, and which may be expected to produce more in the future, is that of complementary color printing, either as transparencies or as prints on paper. The theory underlying this method of working is the same as before, but the different mode of approaching the problem calls for a different set of colors. Instead of adding colors to produce white, the print processes start with white and build up by successive absorption until they reach black. The colors required are minus colors; that is, the nearest approach possible to the color obtained by subtracting each of the three constituents of a three-color white, colors which shall also, when taken together, produce black. These are minus red, or peacock blue, minus green, or pink, and minus blue, or yellow. The first pictures of this sort were obtained by printing the three negatives on bichromated gelatine. After development the three prints were stained with appropriate dyes and superposed, making excellent transparencies. Recent

forms of this process are due to F. E. Ives. One process originated by him has for its essential characteristic the use of bichromated fish glue for the printing surface, whereby very shallow reliefs can be obtained. A later process uses gelatine bromide plates into which a quantity of yellow dye is incorporated, which again serves the purpose of keeping the relief shallow, so that the soaking up of dye-stuff can be accurately controlled.

Two processes carry three-color printing to the form of prints on paper. These are the Koenig Pinatype process and the Sanger Shepherd imbibition process. These both make prints in gelatine, which are transferred by squeegeeing to a gelatine-faced or blotter-like paper.

Another printing process of great interest is the bleach-out process, known as Uto. The central idea of this is the use of a paper coated with a mixture of three dyes of minus color which, together, produce black. Each dye has the property of being faded by its complementary color of light. Consequently, when exposed to a colored image all colors from black to white (complete fading) are attainable. The technical difficulties in the way of this clever idea are many, but a paper has actually been produced upon which prints from color transparencies have been made. At present, however, this process is not a serious rival to the screen plate.

Various cameras for the production of three-color negatives continue to be devised, but their details involve no strikingly new departures other than what may be termed mechanical ones. The use of the screen plate has led attention away from special cameras, but the possible development of improved three-color print processes may direct the ingenuity of inventors back to the problem of securing three negatives from one point of view in some simple and compact camera.

## THE SILVER EQUIVALENT OF HYDROQUINONE<sup>1</sup>

BY M. A. GORDON

One molecular weight of hydroquinone is said by Andresen to reduce two molecular weights of silver bromide when no sulphite is present<sup>2</sup> and four molecular weights when sulphite is present.<sup>3</sup> The actual figures given by Andresen work out about 4.38 instead of 4; but that is of no importance at present. Reeb<sup>4</sup> dissolved silver oxide in a 10 percent sodium sulphite solution and found that one molecular weight of hydroquinone precipitated eight molecular weights of silver. We apparently have the following results:

- 1 M hydroquinone = 2M Ag (AgBr)
- 1 M hydroquinone = 4M Ag (AgBr and Na<sub>2</sub>SO<sub>3</sub>)
- 1 M hydroquinone = 8M Ag (Ag<sub>2</sub>O dissolved in Na<sub>2</sub>SO<sub>3</sub>)

Quite different results were obtained by Mees and Shepard<sup>5</sup> in their study of the chemical reactions of the hydroquinone developer.

"In recent years the work of Andresen, Bogisch and others on development with organic reducing agents has shown that additions of sulphite and of alkali have a direct and hitherto unsuspected effect on the reaction. Thus Andresen<sup>6</sup> has shown that the sulphite takes part directly in the reduction. One of the products, that he obtained after a prolonged development with hydroquinone, was a substance resembling a quinone but containing sulphur. Andresen considered this to be a quinone sulphonic acid. He believes that development takes place according to the following equation:  
$$4\text{AgBr} + \text{C}_6\text{H}_4(\text{ONa})_2 + \text{Na}_2\text{SO}_3 = 4\text{Ag} + 4\text{NaBr} + \text{C}_6\text{H}_3\text{O}_2\text{SO}_3\text{H}.$$

<sup>1</sup> Based on a paper read before the Eighth International Congress of Applied Chemistry in New York, September, 1912.

<sup>2</sup> Eder's Handbuch der Photographie, 5th. edition, 3, 312 (1903).

<sup>3</sup> Namias: Chimie photographique, 264 (1902).

<sup>4</sup> Reiss: Die Entwicklung der photographischen Bromsilbertrockenplatte und die Entwickler, 30 (1902).

<sup>5</sup> Zeit wiss. Photographie, 2, 5 (1902).

<sup>6</sup> Andresen: Phot. Correspondenz, 37, 197 (1900).

Writing this in terms of ions, as Friedländer does, we have:

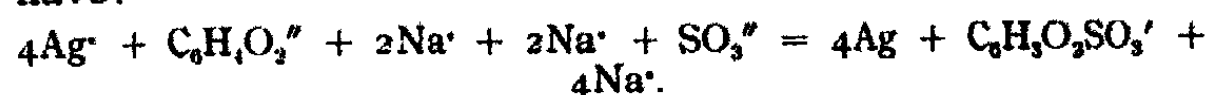

"To determine whether the hydroquinone developer is reversible when no sulphite is present, Friedländer<sup>1</sup> exposed plates in a Scheiner sensitometer and developed them in a hydroquinone potash developer with and without addition of quinone. He found that the developer, to which quinone had been added, developed at least as rapidly as the one containing no quinone. He also found that quinone reacted with potash to form hydroquinone, a result previously obtained by Bogisch.

"The following experiments confirm this completely and also throw some light on the reaction.

#### I. Development with Hydroquinone is a Reversible Reaction

"A fifth normal potassium bromide was saturated with quinone at 20° by prolonged shaking. In 25 cc of the saturated solution were placed two plates of known density, 1.62 and 1.52 according to Hurter and Driffield. After 24 hours the plates were taken out, fixed, and washed. They were perfectly transparent; but the gelatine was stained a deep red. Even under the microscope, no particles of silver were to be seen. The solution had bleached the silver completely. Like the gelatine, the solution was a deep red color. There was no odor of quinone. This experiment confirms the following equation:

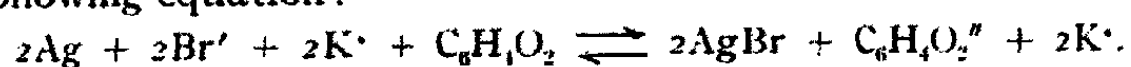

While this reaction was taking place, the hydroquinone solution was oxidized by the air, whence the reddish brown color.

#### II. Free Potash—or Free Hydroxyl Ions—displace the Equilibrium in I Completely

"Friedländer's experiment was repeated in the following

<sup>1</sup> Friedländer: *Phot. Correspondenz*, 39, 252 (1902).

way, using a developer having the composition :

1.1 gram  $C_6H_4(OH)_2$   
2.5 gram KOH  
1.0 cc 2*N* KBr  
100 cc  $H_2O$

Two plates were exposed simultaneously in a Hurter sensitometer and were developed in solutions A and B :

- A. 50 cc solution + 25 cc  $H_2O$   
B. 50 cc solution + 25 cc saturated quinone solution.

“Development took place very rapidly and both images appeared almost instantaneously. At the end of three minutes the plates were fixed and washed. There was only a slight difference between their densities; but the plate developed in the solution to which quinone had been added, was slightly darker than the other. Both plates were deeply colored. Addition of caustic potash to a saturated quinone solution turns it reddish brown, destroys the smell of quinone, and makes the solution a powerful developer.<sup>1</sup> This reaction was studied further because it seemed possible that caustic potash might be changed into potassium peroxide by quinone. To test this, caustic potash was added to a saturated quinone solution, to which was then added a solution of potassium bichromate and sulphuric acid. When the whole was shaken with ether, the reddish brown color prevented the result from being seen. In order to get a reaction which was under better control and which was less affected by atmospheric oxygen, an excess of potassium carbonate was added to an acidified quinone solution. After the evolution of carbon dioxide had ceased, caustic potash reacted with the quinone as before. After adding acidified bichromate and extracting with ether, a deep blue ether extract was obtained, thus proving the occurrence of hydrogen peroxide, a fact which was also established in other ways. The ether was taken from a full bottle and a blank test was made for peroxide.

“Hydroquinone can be extracted with ether and the reaction between quinone and caustic potash—or hydroxyl

<sup>1</sup> Cf. Friedländer: *Phot. Correspondenz*, 39, 252 (1902).

ions—must take place according to the equation:



This equilibrium is displaced by atmospheric oxygen.

### III. The Equilibrium in the Developer is displaced by Sulphite

"The part played by the sulphite has already been mentioned. When a neutral sodium sulphite solution is added to a quinone solution, a reaction takes place giving rise to a greenish yellow color which gradually disappears when sulphite is added in excess. This seems to be due to the formation of quinhydrone. The resulting solution acts as a developer.

"If sodium sulphite and caustic potash are both added to a quinone solution, the solution becomes colorless and soon loses all odor of quinone, at the same time becoming a powerful developer. In order to study this reaction more thoroughly, a quinone solution was added to a sodium sulphite solution which had been freed so far as possible from sulphate. On extraction with ether, hydroquinone was obtained and identified. The aqueous solution gave no more precipitate with barium chloride than did a check solution, but dithionic acid could be detected in it. *The reaction between quinone and sulphite consists therefore in the reduction of quinone to hydroquinone and the oxidation of sulphite to dithionate.* The reaction probably should be written as follows:



We were not able to determine whether this reaction was or was not reversible.<sup>1</sup>

"The formation of dithionate in this way is analogous to many other oxidations of sulphurous acid. Carpenter<sup>2</sup>

<sup>1</sup> K. Schaum obtained no satisfactory measurements of the oxidation potentials of mixtures of sulphite and sulphate. *Zeit. Elektrochemie*, 7, 483 (1901); 9, 406 (1903). It would be interesting to have measurements of the potentials of sulphite-dithionate cells.

<sup>2</sup> *Jour. Chem. Soc.*, 81, 1 (1902). See also Meyer: *Ber. chem. Ges. Berlin*, 34, 3606 (1901).

investigated the oxidation of sulphurous acid by metallic oxides and gives the following table:

Oxide	Percent dithionate	Per cent sulphate
Iron	96.0	not observed
Manganese	95.0	25
Cobalt	36.0	64
Nickel	0.0	100

"We have not followed the reaction quantitatively with quinone; but there seems to be extremely little sulphate formed. Similarly, Bassett<sup>1</sup> found that sulphurous acid is oxidized to dithionic acid when chromates are reduced by sulphur dioxide. This seems to indicate that it is incorrect to assume, as Andresen did, that the sulphite reaction is given by the equation:



The substitution of the  $SO_3H$  group in the benzene nucleus is usually to be brought about only at high temperature and by the use of concentrated sulphuric acid.

"These two quinone reactions are of great significance for the following three points:

1. The process of organic development.
2. The autoxidation of phenolates.
3. The protective action of sulphite and its effect in preventing discoloration.

#### 1. The Development with Organic Reducing Agents

"The action of alkali—or of hydroxyl ions—consists essentially in forming the highly dissociated salts of the organic developers and in thus increasing the concentration of the reducing ions. It is now clear that the presence of hydroxyl ions destroys completely the reversibility of development by hydroquinone. The following observation indicates that the same thing is probably true for other

<sup>1</sup> Jour. Chem. Soc., 83, 692 (1903).

organic developers. E. Diepolder<sup>1</sup> found that the oxidation of *o*-aminophenol by potassium ferricyanide gives rise to a mixture of triphendioxazin and 3-oxybenzolazoxindon:

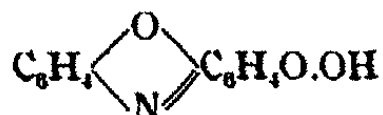

(which is the tautomer of phenoxazin-2,3-quinone). When treated with caustic potash *o*-aminophenol and dioxyquinone are formed, doubtless by reactions analogous to the one involved in the reduction of quinone. One might think that the alkali peroxide, when formed, would take part in the development just as much as the regenerated reducing agent, since it has been shown by LeRoy<sup>2</sup> and by Andresen<sup>3</sup> that an alkaline solution acts as a developer. It is probable that the presence of sulphite prevents this, since the sulphite is oxidized rapidly by peroxide.

"The successive reactions make the determination of the 'absolute reducing power' of organic reducing agents very difficult. The determination of the mechanism and of the velocity function is further complicated by the fact that the rate of the primary, typical reaction,

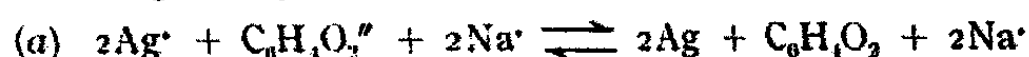

is effected by the later reactions,<sup>4</sup>

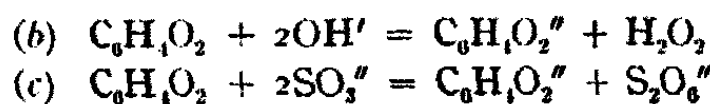

unless the latter take place with a velocity which is infinitely large relatively to that of (a).

"At present it is impossible to formulate a general theory for organic developers because the decomposition products are but rarely known. The papers of Diepolder<sup>5</sup> and of

<sup>1</sup> Ber. chem. Ges. Berlin, 35, 2816 (1902).

<sup>2</sup> Bull. Soc. franç. phot., [2] 10, 23 (1894).

<sup>3</sup> Phot. Correspondenz, 36, 260 (1899).

<sup>4</sup> V. G. Walker: Proc. Roy. Soc. Edin., 22, 22 (1897). "Velocity of Graded Reactions."

<sup>5</sup> Ber. chem. Ges. Berlin, 35, 2816 (1902).



Bamberger and K. Auwers<sup>1</sup> are important in their bearing on this point."

It is clear that Mees and Sheppard consider that hydroquinone reacts with silver bromide in presence of alkalies according to the equation,

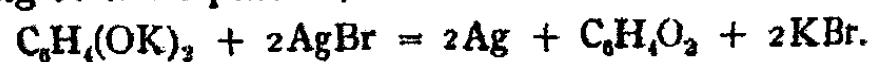

In presence of an excess of alkali, the quinone forms the potassium salt of hydroquinone, and hydrogen peroxide,

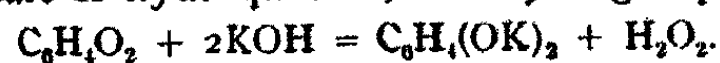

Since both hydroquinone and hydrogen peroxide reduce silver bromide in alkaline solution, there is no apparent reason why these changes should not go on forever, in which case a given amount of hydroquinone would reduce an indefinite amount of silver bromide. A fair statement of Mees's view would be that, in the absence of air, a solution of hydroquinone would reduce any amount of silver bromide, were it not for side reactions which probably occur.

Under the circumstances it seemed as though more experiments were desirable. The silver bromide was prepared by precipitation from a solution of silver nitrate with a slight excess of potassium bromide. The precipitate was washed until the wash water was free from soluble bromides; it was then dried at 110°, ground, and sifted through a 40-mesh sieve. No special care was taken to protect the silver bromide from diffused light because the amount of decomposition due to this cause falls way inside the limits of experimental error. A given amount of alkaline hydroquinone solution was allowed to react with an excess of silver bromide for a given time. The solution was then filtered through a Gooch crucible and the silver-coated silver bromide was washed with water to which a little potassium sulphate was added in case the silver or the silver bromide showed any tendency to go into colloidal suspension. The potassium sulphate coagulated any suspended silver or silver bromide. When the washing was completed, the silver bromide and the asbestos of the Gooch

<sup>1</sup> Ber. Chem. Ges. Berlin, 33 (1900) et ff.

crucible were treated with 1 : 1 nitric acid. The dissolved silver was then titrated with  $N/2$   $\text{NH}_4\text{SCN}$ , using ferric alum as indicator.

The first runs were made to determine the conditions affecting the reaction between silver bromide and hydroquinone. A very few experiments showed that stirring or shaking was essential if complete reduction was to be obtained. This is not surprising because we are dealing with a reaction in a heterogeneous system and consequently rate of diffusion would naturally be an important factor. The machine, which was used to keep the solutions stirred, consisted of a reduction gear run by an electric motor. The reduction gear was fitted with a face-plate which was rotated at the reduced speed. A wooden disc was bolted to this face-plate and the bottle (of about 25-30 cc capacity and closed with rubber stoppers) containing the solution and silver bromide were fastened to the outer edge of the disc. As this disc revolved, the contents of the bottles were kept stirred by the silver bromide falling from one end of the bottle to the other.<sup>1</sup>

The experiments in Table I show how necessary stirring is.

TABLE I

Hydroquinone 0.11 gram, NaOH 2.2 gram, in 25 cc.  
Excess of AgBr. Temperature, ca. 20°

Conditions	Time	Mols Ag reduced per mol hydroquinone
Not shaken at all	1 day	4.19
	2 days	4.13
	3 days	4.76
Shaken by hand	3 days	5.48
	3 days	5.20
	3 days	5.16
Shaken by machine	6 hours	6.38
	6 hours	6.38
	6 hours	6.58

<sup>1</sup> Special experiments showed that the small volume of air left in the bottles did not introduce any serious error.

Experiments on the effect of temperature are given in Table II. In these runs the bottles were shaken occasionally by hand. They show the effect just as well as though the shaking had been done by machine and consequently it did not seem worth while to make a thermostat with a rotating device for this work.

TABLE II  
Hydroquinone 0.11 gram, NaOH 2.2 gram, in 25 cc  
Excess of AgBr. Shaken by hand

Temperature	Time	Mol Ag reduced per mol hydroquinone
ca. 20	6 hours	5.69
65-70°	30 mins.	8.0
95-100°	6 hours	9.29

From these experiments it is clear that the reaction velocity increases rapidly with rising temperature.

A few experiments were made to determine whether light had any marked effect on the reaction. The data are given in Table III.

TABLE III  
A. Hydroquinone 0.11 gram, NaOH 2.2 gram, in 25 cc  
B. Hydroquinone 0.055 gram, NaOH 2.2 gram, in 25 cc  
Excess of AgBr. Temperature, ca. 20°

Sol.	Conditions	Mol Ag reduced per mol hydroquinone
A	Solution exposed only to diffused light	5.84
A	Solution exposed to sunlight	5.69
B	AgBr not exposed	6.05
B	AgBr blackened by light	6.05

The two sets are not comparable one with another; but the two experiments with solution A are comparable and so are the two experiments with solution B. Light has little, if any, effect on the reaction. It is not claimed that equilibrium was reached in these experiments.

The experiments in Table IV show the effect of alkali on the rate.

TABLE IV  
Hydroquinone 0.055 gram, alkali variable, in 25 cc  
Excess of AgBr. Temperature, ca. 20°

Approx. mol alkali per mol hydroquinone	Mol Ag reduced per mol hydroquinone
10 Mol Na <sub>2</sub> CO <sub>3</sub>	3.8
10 Mol NaOH	5.5
100 Mol NaOH	6.4

The rate increases with increasing concentration of alkali. In all experiments a large excess of alkali was used.

Several runs were made to get some idea of how soon equilibrium is reached. In all of these runs a little fresh AgBr was added once or twice daily so as to be certain that there should always be a comparatively clean surface of silver bromide exposed to the hydroquinone. The results are given in Table V.

TABLE V  
Hydroquinone 0.14 gram, NaOH 2.2 gram, in 25 cc  
Excess of AgBr. Temperature, ca. 20°

Time	Mol Ag reduced per mol hydroquinone
6 hours	6.38
6 hours	6.58
8 days	7.8
15 days	7.95
18 days	8.06

Equilibrium has not certainly been reached even at the end of eighteen days. From this experiment and from experiments covering shorter lengths of time, it seems probable that the reaction goes in at least two stages. In the first stage about six molecular weights of silver are reduced in a short time, while the second stage requires a much longer

time, equilibrium not having been reached definitely in eighteen days. At 100° more than nine molecular weights of silver were reduced in 6 hours even though the stirring was less efficient. Of course, there is no certainty that the endpoint is the same at 100° as at 20°. It may easily be that the reaction runs farther at the higher temperature.

Since quinone is presumably one of the oxidation products of hydroquinone, it seemed desirable to determine the silver equivalent of quinone under similar conditions. The data are given in Table VI.

TABLE VI

A. Hydroquinone 0.11 gram, NaOH 2.2 gram, in 25 cc  
 B. Quinone 0.108 gram, NaOH 2.2 gram, in 25 cc  
 Excess of AgBr. Temperature, ca. 20°

Sol	Reducing agent	Mol Ag per mol reducing agent
B	Quinone	4.70
B	Quinone	4.85
A	Hydroquinone	6.38
A	Hydroquinone	6.58

From these experiments it appears that hydroquinone reduces nearly two more molecular weights of silver bromide than does quinone while theory calls for a difference of exactly

TABLE VII

Hydroquinone 0.055 gram, NaOH 2.2 gram, in 25 cc  
 Excess of AgBr. Temperature, ca. 20°  
 M. S. = mol sulphite per mol hydroquinone  
 M. Ag = mol Ag reduced per mol hydroquinone

Time	M. S.	M. Ag	Time	M. S.	M. Ag
4.5 hours	0	6.2	18 days	0	7.63
4.5 hours	2	7.95	18 days	0	7.68
4.5 hours	5	8.25	18 days	1	7.76
4.5 hours	15	8.15	18 days	1	7.68
4.5 hours	0	6.4	18 days	5	8.4
4.5 hours	5	8.4	18 days	10	8.94
4.5 hours	10	8.38	18 days	10	8.94

two provided equilibrium is reached. These experiments make it reasonably certain that the quinone is an intermediate product when hydroquinone reduces silver bromide. It is also very improbable that there is any regeneration of hydroquinone under these conditions.

In Table VII are given data for the silver equivalent of hydroquinone in presence of sodium sulphite.

When sulphite is present, the silver equivalent is only a little higher at the end of 18 days than it is at the end of 4.5 hours, thus showing that at any rate the first stage of the reaction takes place fairly rapidly. For runs of 4.5 hours about two more molecular weights of silver are reduced when sulphite is present in excess than without it. On the eighteen days' run this difference drops to about one molecular weight of silver. Since this change is due to an increase in the silver equivalent when no sulphite is present, it is probable that the reaction proceeds along different lines when sulphite is present. In the short runs the silver equivalent is practically the same for amounts of sulphite varying from five to fifteen molecular weights per molecular weight of hydroquinone.

In order to determine whether the increased silver equivalent in presence of sulphite was due to an oxidation of the sulphite or to an increased reducing action of the hydroquinone, a determination was made of the amount of sulphite left in the solution. After the reaction had been allowed to run as long as wished, the solution was poured through a Gooch filter and the mixture of silver bromide and silver was washed. The filtrate was transferred to a small round-bottomed flask of about 150 cc capacity, which was fitted with a separatory funnel and with a glass tube which led to a series of two U-tubes containing half normal iodine solution. To the solution in the flask was added about 15 cc concentrated sulphuric acid containing sufficient silver sulphate to react with any hydrobromic acid set free on acidifying. After all the acid had been added, carbon dioxide was run through

the apparatus and the flask was heated to drive off all the sulphur dioxide, which was then taken up by the half-normal iodide solution in the U-tubes. A third U-tube, containing potassium iodide solution, was placed at the end of the series to take up any iodine which might be volatilized and driven over from the other two tubes. The amount of sulphite could be determined from the change in the titer of the iodine solution. This method of analysis is not very accurate but the data in Table VIII seem to show that one molecular weight of sulphite has been oxidized and that the extra two molecular weights of silver are due to this cause.

TABLE VIII

Conditions	Mol sulphite taken	Mol sulphite oxidized
Blank	3.82	0.0
AgBr	2.52	1.30
AgBr	2.78	1.04

Since the amount of sulphite oxidized does not increase when the molecular ratio of sulphite to hydroquinone increases from 5-15, it is evident that the direct reduction of silver bromide by sodium sulphite is small under the conditions of the experiment and that we must be dealing with a coupled reaction of some sort. Some experiments were made to show that the coupling takes place with hydroquinone and with quinone rather than with any of the oxidation products of quinone. The data for hydroquinone are given in Table IX.

When the sulphite is added toward the end of the run it has practically no effect; when it is added before the run, the silver equivalent is increased by nearly 2; when the sulphite is added just after the run has started the silver equivalent is increased by about 1. The increase of about one in the silver equivalent when the sulphite is added just after the run begins, might be a coincidence due to the hydroquinone being partially oxidized; but the data in Table X rather imply that

TABLE IX  
 Hydroquinone 0.055 gram, NaOH 2.2 gram, in 25 cc  
 Excess of AgBr. Temperature, ca. 20°  
 Time of run, 3 hours

Mol sulphite per mol hydroquinone	Conditions	Mol Ag reduced per mol hydroquinone
0		6.3
10	Sulphite added before run	8.05
10	Sulphite added 5 minutes after run started	7.2
10	Sulphite added 15 minutes before run ended	6.3

the oxidation to quinone takes place very rapidly and that we are really dealing with quinone.

TABLE X  
 Quinone 0.054 gram, NaOH 2.2 gram, in 25 cc  
 Excess of AgBr. Temperature, ca. 20°

Time	Mol sulphite per mol hydroquinone	Mol Ag reduced per mol hydroquinone
1 hour	0	3.9
1 hour	5	4.9
1 hour	10	4.95

Under these conditions we get one more molecular weight of silver reduced in presence of an excess of sodium sulphite. The induced reaction apparently takes place in two stages, one-half molecular weight of sodium sulphite being oxidized while one molecular weight of hydroquinone is being oxidized to quinone, and the other half molecular weight of sodium sulphite being oxidized while quinone is being oxidized to something else. It would have been interesting to study this further as a case of an induced reaction; but that would have been entirely outside the scope of this present paper.

A few experiments were also made to determine the



silver equivalent of hydroquinone with other silver salts than the bromide. The data are given in Table XI.

TABLE XI  
Hydroquinone 0.55 gram, 20 cc  $\text{NH}_4\text{OH}$  (sp. gr. 0.90), and variable  $\text{AgNO}_3$ , in 40 cc solution. Temperature, ca.  $20^\circ$

Time	$\text{AgNO}_3$ grams	Mol Ag reduced per mol hydroquinone
5 mins.	0.85	5.11
5 mins.	1.7	6.67
2 days	1.7	6.82
8 days	1.7	8.03

Silver sulphite 1.87 gram, sodium sulphite 3.78 gram, hydroquinone 0.055 gram,  $\text{NaOH}$  2.2 gram, in 40 cc. Temperature, ca.  $20^\circ$

Time	Mol Ag reduced per mol hydroquinone
5 mins.	8.2

Hydroquinone 0.055 gram,  $\text{NaOH}$  2.2 gram, in 25 cc  
Excess of  $\text{Ag}_2\text{O}$ . Temperature, ca.  $20^\circ$

Time	Mol Ag reduced per mol hydroquinone
5 mins.	10.4 <sup>1</sup>
15 hours	10.5

<sup>1</sup> Subsequent measurements under different conditions have given a value of about 7.5. The exact effect of the conditions is being investigated.

The reaction apparently takes place very rapidly with silver oxide and alkali, and the silver equivalent is very high, being higher in five minutes than that obtained for silver bromide after heating at  $100^\circ$  for 6 hours. The reaction is also very rapid with silver sulphite dissolved in sodium sulphite, an equivalent of about 8 being obtained in 5 minutes. No attempt was made to determine the equilibrium and no measurements were made as to the amount of sulphite oxidized. It is probable that the same relations hold as in the case of silver bromide and sodium sulphite. With ammoniacal silver nitrate a silver equivalent of nearly 7 is reached very

rapidly and this creeps up to about 8 in the course of about as many days.

In relatively few of the experiments are the silver equivalents integers. The variations may be due in some cases to experimental error; but that is undoubtedly not the explanation in all cases. There are two other ways, besides experimental error, in which a reaction taking place according to definite proportions may appear not to. We may be dealing with a reaction which does not run to an end or we may have the reducing agent oxidized in two or more different ways in which case we should be measuring the sum of two reactions, neither of which perhaps runs to an end. Theoretically the reactions do not run to an end because the reducing power of the solution varies with the concentration. It is quite probable, however, that the effect due to this is negligible. In view of the difficulty of coming out with only one product when making organic preparations, it is very improbable that the oxidation of hydroquinone proceeds along one line only. This view is confirmed by the fact that the silver equivalent of hydroquinone is about eight on long runs (cf. Table V), while the value is under nine in presence of an excess of sulphite (cf. Table VII) even though the sulphite certainly contributes two to the silver equivalent and possibly more on the long runs.

A few runs were made incidentally with other developers. The data for pyrocatechol are given in Table XII and those for pyrogallol in Table XIII.

The experiments with pyrocatechol show that the reaction apparently reaches an end inside of 2 hours, the silver equivalent being about 4.5. When sulphite is present, there is an additional reduction of 1.0-1.5 mols of silver. It would probably be safe to say that about one more mol of silver is reduced in presence of sulphite. The sulphite seems to have no effect on the silver equivalent of pyrogallol. Hurter and Driffeld<sup>1</sup> found a silver equivalent of four for pyrogallol

<sup>1</sup> Phot. Jour., 22, 194 (1898).

TABLE XII

Pyrocatechol 0.055 gram, NaOH 2.2 gram, variable sodium sulphite in 25 cc. Excess of AgBr. Temperature, ca. 20°

Time	Mol sulphite per mol pyrocatechol	Mol Ag reduced per mol pyrocatechol
2 hours	0	4.4
2 hours	5	5.45
2 hours	10	5.75
3 hours	0	4.35
3 hours	5	5.5
3 hours	10	5.35
6 days	0	4.45
6 days	5	5.85
21 days	0	4.5
21 days	5	5.9

TABLE XIII

Pyrogallol 0.063 gram, NaOH 2.2 gram, variable sodium sulphite, in 25 cc. Excess of AgBr. Temperature, ca. 20°. Time of run 1 hour

Mol sulphate per mol pyrogallol	Mol Ag reduced per mol pyrogallol
0	3.25
5	3.45
10	3.40

when acting on ammoniacal silver nitrate. Andresen<sup>1</sup> obtained a value of two for pyrocatechol when acting on silver bromide in presence of sulphite.

Since the experimental part of this paper was finished, there has appeared an article on "The Chemistry of Hydroquinone Development" by Messrs. Luther and Leubner.<sup>2</sup> They were especially interested in the chemical part which sodium sulphite plays in photographic developers. They say, however, that "this problem cannot be solved satisfactorily while the course of development done without sulphite remains unknown, and therefore, it is necessary in the first place to obtain a clear idea of the course of these reactions.

<sup>1</sup> Namias: *Chimie photographique*, 264 (1902).

<sup>2</sup> *Brit. Jour. Photography*, 59, 632, 653, 673, 692, 710, 729, 747 (1912).

"We chose the hydroquinone developer, in the first place because its products of oxidation and the additive compounds which it forms are better known than those of any other photographic developer; and the reaction, in spite of the high 'relative reducing power,' to use Andresen's expression, takes place more slowly when using an alkaline carbonate than in the case of the so-called rapid developers. As the final products of the reactions are unknown and can be separated and recognized only with difficulty, and as also the chief reactions are obscured by a large number of intermediate changes, we attempted, first of all, to obtain some light on the subdivisions of the chief reactions as well as to study the quantitative nature of the reaction as a whole.

"In order to compare the values obtained in the separate estimations, the method of work was of importance. Our first work, therefore, was to devise a useful method. After having tried the various ways for the determination of the reducing hydroquinone in homogeneous systems without success, we turned to the methods employed by Andresen<sup>1</sup> for the determination of the relative reducing powers of organic developers. We used freshly precipitated silver bromide of the greatest possible uniformity in its chemical and physical properties, making the various experiments with exactly the same excess of potassium bromide. The rates of reduction were found by determining the silver bromide reduced during measured times, by an alkaline developing solution of known strength, the reduced silver being estimated by a titration method.

"As we were working in a heterogeneous system, we had to confirm the effect of diffusion on the measured reaction velocity. This was done by systematically modifying each factor which influenced diffusion. These are, for example, enlargement of the surface of silver bromide, variation in the speed of shaking, and the temperature. Since the temperature coefficient in purely chemical reactions is greater than

<sup>1</sup> Phot. Correspondenz, 27, 635 (1890).

that in those involving diffusion, it follows that at higher temperatures the speed of diffusion determines, in an increasing degree, the measured speed of reduction. First of all we ascertained, for the various reactions, those limits of temperature within which practically only the reaction velocity is of importance, and we could then investigate the mechanism of a homogeneous reaction in the usual way. Making such measurements at different temperatures, we were able to separate the various partial reactions. Intermediate reactions, which take place so quickly at relatively high temperatures that they elude measurement and thus appear to be missing from the series, could be recognized by lowering the temperature. Inversely, by raising the temperature the conditions were made more favorable to the recognition of other stages of the reaction, which, at lower temperatures, proceeded so slowly as to be incapable of measurement.

“In order, as far as possible, to exclude errors inherent in the method, we examined the influence of the air contained in a vessel in which the materials were shaken; we also examined the effect of various ‘inert’ bodies, as well as the possible effect of light. Short exposure to light of the silver bromide which we used had no effect on the course of the reaction, or so slight an effect that any errors fell within those of the method itself. Nevertheless, we made it a practice to work in the dark room illuminating by as constant as possible a source of orange light.

“In the case of reduction, which took place slowly, the existence of an ‘induction period’ could be recognized. Mention is made in our dissertation as to the manner of this observation. The values found for the various determinations involved certain experimental errors and are not readily precisely reproducible. The average was taken of a number of determinations, and only when the differences found lay outside the limits of error did we take this mean value into consideration as to the effect of fresh influences.

"After a suitable method of work had been found, we proceeded to study the chemical process of development without sulphite. We examined the effects of variation in the strength of hydroquinone and alkali, also the effect of potassium bromide on the reaction. By modifying the concentrations of the bromide ions, we found that hydroquinone does not react with the solid silver bromide but reacts with the Ag ion formed by the dissociation of the dissolved silver bromide. The reaction velocity is proportional to the concentration of the silver ion.

"By modifying the concentration of the hydroquinone and of the alkali, it was found that it was not the free hydroquinone which reacts, but, presumably, the anion  $C_6H_4O_2^-$ . By kinetic experiments it was found that the neutralization by  $OH^-$  takes place quickly, but not instantaneously; in the case of a small concentration of hydroxyl ions it requires an appreciable time.

"In kinetic experiments it was found that the reaction comes to a stop after a relatively short time. The state which corresponds with this strong retardation of the reaction cannot be expressed by any simple formula; the condition, in fact, undergoes alteration within very wide limits by modifying the external conditions, such as the temperature. This argues that the above-mentioned stoppage of the reaction is conditioned, not by the course of a simple process which can be expressed by a simple quantitative formula, but is caused by the production of restraining substances. A great part of our work consisted in investigating this phenomenon—that is, the appearance and nature of the restraining substances, as well as the nature of the restraint.

"In the first place, the assumption that a part is played by the formation of quinhydrone was investigated. Quantitative experiments showed that, even in a neutral solution, the existence of appreciable quantities of quinhydrone is not possible. The dissociation constant (quinone)(hydroquinone)/quinhydrone is about 0.23 at 25°. The succeeding experi-

ments were concerned with the investigation of the restraining effect of quinone on the speed of the reaction and the cause of this restraint. Here we were able to ascertain that later stages of the reaction consist of the formation of quinonate from the quinone and the alkali. In this fixation of the hydroxyl ions one sees the cause of the stoppage of the reaction. The fact that the reaction does not stop completely, but continues further, and this more quickly as the temperature is higher, may be explained by the proof that neither quinone nor quinonate itself reduces, but that the quinonate is decomposed into a hydroquinone and a higher decomposition product of quinone by taking up of water and partial liberation of the alkali combined with the quinone. Thus, by this decomposition of the quinone, there is a regeneration of the reducing hydroquinone on the one hand, and, on the other, an increase in the concentration of the hydroxyl ions owing to alkali being set free. The restraining effect of the presence of quinone is thereby removed. Experiments on the course of the reaction at different temperatures gave entirely similar results except that the stage at which the reaction stopped was always further the higher the temperature. On ground of analogy it may be concluded that the processes which give rise to the apparent stoppage of the reaction at higher temperatures are quite analogous to those more exactly investigated at lower temperatures.

“Experiments lasting over a considerable period of time at a sufficiently high temperature indicated the probability that, as a general rule, the oxidation of hydroquinone by means of silver bromide leads to the formation of dioxyquinone. Further oxidation is, of course, not impossible, but it proceeds so slowly that practically it need not be considered.

“Based on all these observations and measurements a conception may be formed with a high degree of probability as to the course of the reaction between hydroquinone and silver bromide. In setting forth here the various separate stages of this reaction together, it must be pointed out that the

effect of increase of temperature would probably be only to alter the speed of the various intermediate reactions and not to alter their character.

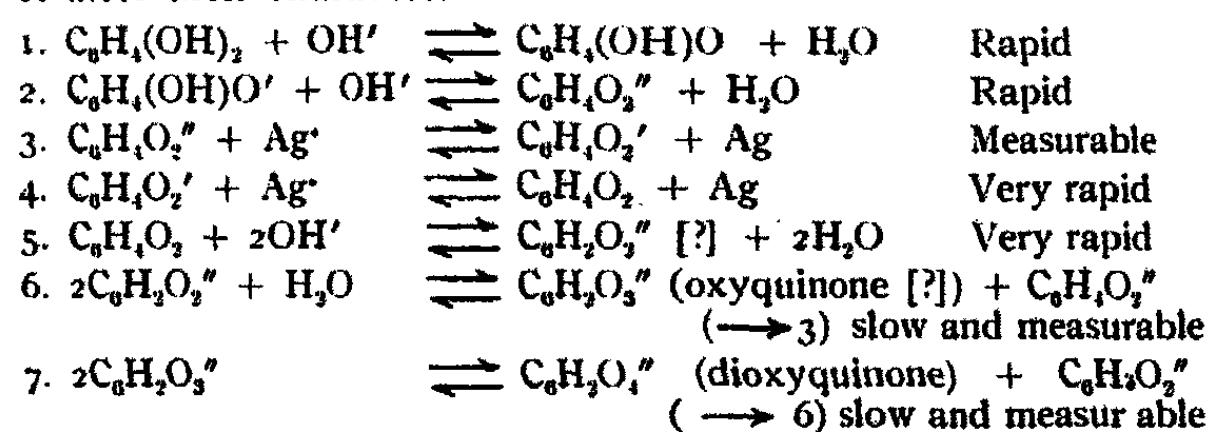

Obviously, this series of reactions represents the partial reactions only approximately. Thus, for example, the measurement described in our German dissertation can be interpreted, not only by reaction No. 3 of the above series, but equally well by Nos. 2 and 3.

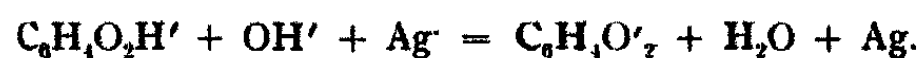

Similarly the processes 5, 6 and 7 are more or less hypothetical, being based on analogy. We wish especially to mention that it was only during the course of the work that we obtained an idea of the stages of the reaction which was in some measure satisfactory. We, therefore, put forward our results as a first general survey of the subject.

[If the ion notation is dropped, the essential part of the hypothesis put forward by Luther and Leubner can be written as follows:

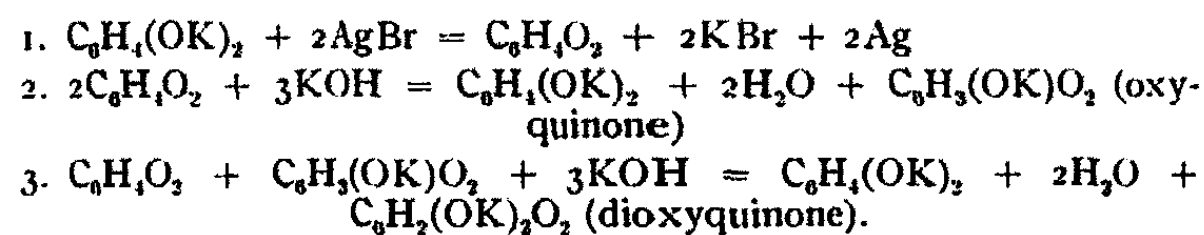

If the oxyquinone stage is cut out Nos. 2 and 3 are to be added together to form a new No. 2.]

“Having obtained this conception of the reaction in the absence of sodium sulphite, experiments were made on the part played by sulphite in the developer. Since the kinetics



of the process are disturbed by the solubility of the silver halide in sulphite, we first determined this in the case of silver chloride and bromide. By altering the strength of the sulphite and by determining the effect of chloride and bromide, we obtained, as the formula of the complex anion formed,  $\text{Ag}(\text{SO}_3)_2^{''}$ . The constant for  $\text{Ag}(\text{SO}_3)_2^{''}/(\text{Ag}^+)(\text{SO}_3^{''})^2$  was found to be about  $2.5 \times 10^4$  at  $25^\circ$ .

"The final product in the reaction of  $\text{C}_6\text{H}_4\text{O}_2$ " +  $\text{OH}'$  +  $\text{Ag}'$  was found to be dioxyquinone. The extent of the reduction in the presence of sodium sulphite, however, exceeded this limit by about 0.43 atoms oxygen per molecule hydroquinone (0.86 Mol Ag per mol hydroquinone). A small portion of this increased action can be explained by the fact that sulphite alone also reduces small quantities of silver bromide. We endeavored to find further facts explaining the action of sulphite, without, however, arriving at any certain results."

"The fruitless results of our first experiments showed the great effect of various minor conditions of experiment. In the first place it was found of importance for all the separate estimations to use a silver bromide of the same chemical and physical properties. According to the nature of its precipitation, silver bromide contains occluded quantities of excess of potassium bromide or silver nitrate which are difficult to remove by washing and which are therefore variable. For this reason we used silver bromide precipitated with a constant excess of potassium bromide<sup>1</sup> = 0.0247 mol/liter, adding silver nitrate to potassium bromide at ordinary temperature. In this way a curdy silver bromide is obtained which becomes transformed into the granular form after standing for a considerable time. This slow, irreversible process is accelerated by raising the temperature. In order to work always with the same superficial area and the same form of silver bromide<sup>2</sup>

<sup>1</sup> Stock solutions: silver nitrate, 0.800 mol/liter; potassium bromide, 1.058 mol/liter. Since 10 cc of each solution were taken and diluted to 105 cc, the actual reacting solutions were 0.076 M  $\text{AgNO}_3$  and 0.1007 M  $\text{KBr}$ .

<sup>2</sup> Drucker: Zeit. Kolloidchemie, 4, 216 (1908).

we precipitated the silver bromide by mixing 10 cc. 0.800 M silver nitrate [diluted to 105 cc] and 10 cc 1.058 M potassium bromide [diluted to 105 cc], heating the mixture to boiling and cooling rapidly, shaking the mixture vigorously as it cooled. The silver bromide so obtained was prepared in 125 cc flasks, in which the complete determination was carried out. According to the particular experiment we added potassium carbonate, water, potassium bromide, etc., to the silver bromide, placing the flasks in a shaking apparatus into a thermostat. The potassium nitrate in the preparation of the silver bromide thus remained in the reaction mixture.

"At the same time the solutions of the other substances taking part in the reaction (hydroquinone, quinone, quinhydrone, potassium carbonate, water, etc.) were brought to the same required temperature. After these had been added to the silver bromide in the flask (time for this, ten to fifteen seconds), the whole was shaken in the thermostat under water for from one minute to five hours. The flasks were closed with well-fitting corks. Paraffined corks, which break off readily, were used only for the experiments with sulphite. That the flasks were thereby perfectly closed was tested by filling them partly with a silver nitrate solution, closing with the cork, and shaking in a thermostat filled with a common salt solution. No turbidity was produced even after long shaking.

"After shaking, the solution was filtered quickly (in from ten to fifteen seconds) from the precipitate, washed first with cold and then with hot water, and, lastly, the precipitate rinsed back into a flask. The reduced silver was then separated from the unreduced silver bromide by warming with ferric ammonium sulphate ( $0.025 \times 2 \text{ mol Fe}^{+++}$ ) and 2-5 cc strong sulphuric acid per liter. Without separating the solution from the excess of silver bromide we then titrated the ferrous salt with potassium permanganate,<sup>1</sup> and then de-

<sup>1</sup> The potassium permanganate was standardized with potassium tetroxalate.

terminated the dissolved silver salt in the same solution with ammonium sulphocyanate by Volhard's method.<sup>1</sup> This method was selected since a check determination is obtained by the titration with permanganate. A small difference between the figures obtained for the silver and with the permanganate is doubtless caused by small quantities of hydroquinone and sodium sulphite which had not been completely removed when washing the silver bromide precipitate.

"The following short table shows the extent of these differences:

	Mol Ag per mol hydroquinone <sup>2</sup>	
	KMnO <sub>4</sub>	NH <sub>4</sub> SCN
AgBr + Ag badly washed; hydroquinone without sulphite	3.12	2.84
AgBr + Ag well washed; hydroquinone without sulphite	2.90	2.86
AgBr + Ag badly washed; hydroquinone with sulphite	4.10	3.86
AgBr + Ag well washed; hydroquinone with sulphite	3.58	3.58

"As a measure of the amount transformed in the reaction velocity experiments, the more accurate figures given by the sulphocyanate were used invariably. The materials used in the experiments (quinone, hydroquinone, quinhydrone, silver nitrate, potassium bromide, potassium carbonate, etc.) were obtained in every case from the firm of Kahlbaum, Berlin, and were not purified further. It should lastly be mentioned that the potassium carbonate was weighed out roughly and that measured quantities of a stock solution were used for the various experiments."

Luther and Leubner showed that the amount of silver

<sup>1</sup> Volhard: Liebig's Ann., 190, 23 (1878). In order to test the use of the iron-alum method we made comparative experiments against Volhard's methods and obtained good results.

<sup>2</sup> [Messrs. Luther and Leubner give their data in atoms of oxygen per molecule of hydroquinone. These have been recalculated throughout into terms of mol Ag per mol hydroquinone.]

bromide, reduced in a given time, increased with the rate of stirring. At 55°, with 60 revolutions per minute, the silver equivalent was 4.64 at the end of an hour. Special experiments showed that no appreciable error was caused by the air in the reaction flasks, by the potassium nitrate in solution, or by the action of moderate light. This is in accordance with the results given in Tables I-III. The relatively low silver equivalent found by Luther and Leubner is due to the use of sodium carbonate instead of sodium hydroxide (cf. Table IV), to the presence of bromide in the solutions, and to the shortness of the runs.

Their results on the effect of quinone<sup>1</sup> are interesting in their bearing on the work of Mees and Sheppard.

"If quinone be added to a solution of hydroquinone and potassium carbonate, and if the reducing effect during one minute be measured immediately, it is found that addition of the quinone retards the development process strongly. However, if a developer containing quinone, hydroquinone, and potassium carbonate be allowed to stand for some time before its reducing effect be determined, the values obtained during one minute show that the arresting effect has disappeared. Friedländer<sup>2</sup> found that a developer with quinone added developed at least as quickly as one without quinone, and he makes no reference to the retarding effect of the quinone. We will now discuss the cause of this retarding influence. We allowed a hydroquinone solution of definite composition to stand for a long time with a potassium carbonate solution of known strength, the mixture being under kerosene so as to exclude air as far as possible. This long contact is necessary for the complete formation of the hydroquinonate. The reduction of the OH' concentration thereby produced, retards the decomposition of the added quinone. In the various experiments the quinone was first added to the silver bromide and then, immediately after the addition of the

<sup>1</sup> Luther and Leubner: *Brit. Jour. Photography*, 59, 711 (1912).

<sup>2</sup> *Phot. Correspondenz*, 30, 253 (1902).

hydroquinone and potassium carbonate, the reducing effect during one minute was measured."

Luther and Leubner suggest four possible explanations for the retarding action of quinone:

(1) The assumption of a hypothetical non-reducing addition product (resembling quinhydrone) by which two to five molecules of hydroquinone are removed for one molecule of quinone.

(2) Adsorption of quinone by silver bromide might also be the cause of the decrease in the reaction velocity.

(3) The effect of quinone on the equilibrium

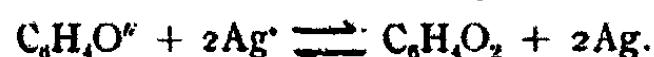

(4) Quinone, functioning as an acid, neutralizes the  $\text{OH}'$  resulting from the hydrolysis of the potassium carbonate and thereby decreases the formation of the reducing ions  $\text{C}_6\text{H}_4\text{O}_2''$ .

The authors reject the first hypothesis because it seems to them improbable that there is a compound of quinone with five molecules of hydroquinone, which is the compound that one would have to assume in order to account for the facts. The experiments showed no indication of a retardation due to adsorption, so the second hypothesis goes by the board. The third hypothesis cannot be tested because quinone decomposes in alkaline solution.

"We have thus to come to the fourth hypothesis, namely the functioning of quinone as an acid and the consequent neutralization of the hydroxyl ions. We know that hydroquinone as acid does not develop but only when present as a bivalent ion  $\text{C}_6\text{H}_4\text{O}_2''$ . This formation of hydroquinonate is dependent on the hydroxyl ion concentration, which latter depends in turn on the ratio of  $\text{CO}_3'' : \text{HCO}_3'$ . The action of quinone, which is an acid according to Euler and Bolin and probably a dibasic one, would be that, according to the equation

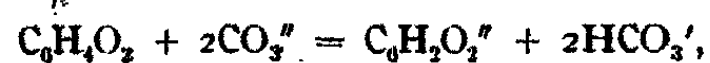

the ratio of carbonate to bicarbonate is decreased and thereby the concentration of the hydroxyl ion. From this considera-

tion it follows that the action of quinone as an acid consists simply in the formation of two mols of  $\text{HCO}_3'$  from two mols of  $\text{CO}_3''$ . The same action should result if, in a comparative experiment, the double quantity of carbonate be replaced by bicarbonate." Experimentally there was a reduction of the reaction velocity when bicarbonate was added to a mixture of hydroquinone and potassium carbonate which has stood some time. The concentration of hydroxyl ions is reduced and the rate of reaction, which depends on the hydroxyl ion concentration, is thereby reduced to about half the value that it had when no potassium bicarbonate was added. The authors conclude that the most probable cause of the retardation by quinone is its acid effect. Its neutralization is, however, only transitory, and in proportion as it decomposes, the alkali is again liberated partially.

"If equivalent quantities of quinone and hydroquinone are allowed to stand in aqueous solution for various times, if this solution is then added to an alkaline mixture of silver bromide and potassium carbonate, and if measurements are made of the reduction during one minute, it is found that the mixture of quinone and hydroquinone possesses no reducing properties, nor does it obtain them on long standing in aqueous solution. If, however, quinone and hydroquinone are left to stand for a considerable time with potassium carbonate, the solution acquires reducing properties. The disappearance of this retarding effect of quinone may depend on one hand on the slow formation of quinonate just as in the case of the hydroquinonate. On the other hand, quinone, by the action of alkali, may be split up into an oxidation and reduction product. Similar reactions are frequently met with in chemical literature.<sup>1</sup>

"After long action of air-free potassium carbonate solution on quinone we obtained hydroquinone by extraction of

<sup>1</sup> Luther: *Zeit. phys. Chem.*, 34, 448 (1900); 36, 385 (1901).

the solution with ether.<sup>1</sup> This experiment thus contradicts the view that the destruction of the retardation depends on the formation of a quinonate of reducing properties. At the same time it points to the decomposition of quinone by alkali. According to this view, quinone forms a quinonate with the alkali; this decomposes into hydroquinone and into a higher oxidation product of quinone, presumably oxyquinone. If this oxyquinone is likewise a dibasic acid, it follows that, on the decomposition of the quinone, part of the alkali combined with the latter is liberated and increases the hydroxyl ion concentration."

Luther and Leubner thus agree with Mees and Sheppard that quinone is decomposed by alkali and that hydroquinone is one of the reaction products. They differ absolutely as to the other product. Mees and Sheppard claim to have proved that the other product is hydrogen peroxide while Luther and Leubner believe that there is formed an oxidation product of quinone—presumably oxyquinone or dioxyquinone. The weak point in the position taken by Mees and Sheppard is that they are forced apparently to assume that the silver equivalent of hydroquinone is infinite. On the assumption of dioxyquinone as end-product we deduce a silver equivalent of six which is not unreasonable for short runs. On the other hand Luther and Leubner have not isolated either oxyquinone or dioxyquinone and they have no test, direct or indirect, showing the presence of either of these substances. Mees and Sheppard have not isolated hydrogen peroxide apparently, but they have obtained the blue color with chromic acid and ether. The only way out of the difficulty is the assumption that other substances beside hydrogen peroxide give this test; and for that there is as yet no experimental evidence. It is an interesting fact that quinone blues tetra-

<sup>1</sup> Hesse (Liebig's Ann., 220, 367 (1883)) has likewise obtained hydroquinone and dark brown oxidation products by treating quinone with sodium acetate. The sodium acetate is not altered thereby. Scheid (Liebig's Ann., 218, 227 (1883)) by heating quinone with air-free water to 100° in a sealed tube, also obtained hydroquinone, quinhydrone, and brown decomposition products.

methyleneparaphenylene diamine paper, which was originally considered by Wurster as a conclusive proof of the presence of hydrogen peroxide. It is at least an open question whether hydrogen peroxide can exist in appreciable quantities in an alkaline solution of hydroquinone. Quantitative experiments on this point are now under way in the Cornell laboratory.

In the last portion of the paper, Luther and Leubner<sup>1</sup> discuss the part played by sodium sulphite in the reaction. "Comparison of the final stage of the reaction with and without sulphite affords an opportunity for the explanation of the processes taking place in the developer. Without sulphite we obtain dioxyquinone as the final oxidation product of hydroquinone in alkaline solution under the conditions of our experiments. The reaction gradually approaches this final stage, but does not reach it on account of the oxidizing effect of the air in the shaking vessel. But in the presence of sulphite the reaction, even at low temperature, proceeds very quickly to dioxyquinone and exceeds this latter by 0.43 atoms of oxygen per molecule of hydroquinone [0.86 mol Ag per mol hydroquinone]. Hurter and Driffield, when determining the relative reducing powers of organic development, found that a solution of hydroquinone, potassium carbonate, and sodium sulphite required 4 atoms of oxygen [8 mols Ag] for its oxidation. The oxidizing agent used by them was ammoniacal silver solution.

"As already mentioned, Sheppard and Mees take the view that sulphite in developer immediately reforms the reducing substance, itself becoming converted into dithionate. If this were the case, the final stage of the reaction would depend greatly on the concentration of the sulphite. We found, however, that a fourfold increase in the proportion of sodium sulphite had only a slight effect. Experiments, which we undertook, on the reducing action of sodium sulphite on silver bromide indicated that sulphite is able to reduce only

<sup>1</sup> Brit. Jour. Photography, 59, 749 (1912).



small quantities of silver bromide, which do not suffice to account for the difference found in respect to the final stage. The question as to the cause of this difference cannot be answered until one makes quantitative measurements of the content of sodium sulphite or its reaction products at the end of the reaction. Attempts to do this with iodine proved to be interfered with by the oxidation products of hydroquinone. If the final solution was freed from sulphite, sulphate and dithionate, by addition of barium chloride, and the whole then oxidized with iodine to barium sulphate, a determination of the sulphite could be made. Our apparatus not allowing of removal of air during the reaction, the work was done in an atmosphere of nitrogen. The total reaction cannot be the same with and without sulphite. The reactions without sulphite depend, in a characteristic fashion, on the temperature, the corresponding curves exhibiting pronounced differences in direction. The cause is the dependence of the rate of decomposition of quinone or oxyquinone upon the temperature. In the case, however, of reactions with sulphite, the effect of temperature is quite different. It may, therefore, be concluded that the sulphite prevents the intermediate formation of quinone and oxyquinone."

"In the work on addition of sulphite, some phenomena were noticed which possibly may be of importance in further experiments in this field. If quinone be decomposed with an alkali, there is produced a yellowish green color which soon becomes deep brownish black in the air. By addition of sodium sulphite to the quinone, or to its alkaline solution, an intense greenish blue color is obtained which gradually becomes bright yellow. If this bright yellow solution is shaken with air it again becomes green, afterwards once more changing to bright yellow. If, however, before the addition of sulphite the small quantities of oxidation products produced during the solution of the quinone be destroyed by traces of  $\text{KHSO}_3$  or hydroquinone, the greenish blue color is no longer produced, the solution becoming brown. By varying

the experimental conditions the conclusion was arrived at that the greenish blue color arises from the formation of small quantities of an oxidation product of quinone. The retardation of the green coloring by reducing agents, such as acid sulphite or hydroquinone, accords with this.

"Rothmund<sup>1</sup> examined the action of acetone on alkaline sulphites and proved the existence of a compound of acetone and sulphite. He found that this acetone-sodium sulphite reacts strongly alkaline. As quinone is likewise a ketone, its action on  $\text{KHSO}_3$  and  $\text{Na}_2\text{SO}_3$  was investigated in a similar manner; but no alkaline reaction to litmus could be detected.

"Euler and Bolin assume that hydroquinonates are colored yellow. In view of the time occupied in neutralizing hydroquinone, the formation of this salt must go hand in hand with a molecular rearrangement (Hantzsch). This would agree with the difference in color between the colorless hydroquinone and the colored hydroquinonate of Euler and Bolin, but the yellow color observed by these would appear really to be caused by the formation of some quinonate. If the hydroquinone solution is treated with quite a small quantity of potassium bisulphite and if an alkaline carbonate is then added, a colorless solution is obtained which certainly contains hydroquinonate. Thus, from our experiments it would seem probable that the hydroquinonate is colorless; quinonate, yellow, oxyquinonate, green; and dioxyquinonate, reddish brown."

Luther and Leubner found a silver equivalent of nearly 7 for hydroquinone in presence of sulphite whereas I obtained a value of about 8 for short runs and of about 9 for long runs. Since Luther and Leubner used potassium carbonate instead of caustic soda, the difference in the results is undoubtedly due to the difference in alkalinity. Since Luther and Leubner were not able to determine the amount of sodium sulphite used up, they were not able to establish any quantitative

<sup>1</sup> Akad. Wiss. Wien., 114, II, 1083 (1905).

relation between the consumption of sulphite and of hydroquinone. This is probably the reason that they were so much puzzled by the increase in the silver equivalent due to the presence of sulphite. They are right, however, in pointing out that their results disprove the contention of Mees and Sheppard that hydroquinone is regenerated at the expense of the sulphite. If this were so, the silver equivalent of hydroquinone should run up to an abnormally large figure in presence of sodium sulphite. There seems to be no reason to doubt the accuracy of the observations made by Mees and Sheppard. It is probable that the error is in the conclusions drawn from the experiments. Mees and Sheppard shook quinone and sodium sulphite together and obtained hydroquinone and dithionate. We may grant this without admitting that the same reaction will necessarily take place in a more alkaline solution and in presence of silver bromide and metallic silver.

The general results of this paper are as follows:

1. The silver equivalent of a developer is defined as the number of molecular weights of silver reduced from a given silver salt by one molecular weight of the developer.

2. Working with hydroquinone, Andresen obtained a silver equivalent of 2 with silver bromide and one of 4 with silver bromide in presence of sodium sulphite. Reeb obtained a value of 8 with silver oxide dissolved in sodium sulphite.

3. Reeb's results have been confirmed, and Andresen's to the extent that sulphite raises the value by 2. Andresen's absolute figures are not confirmed. The discrepancy is undoubtedly due, to some extent, to lack of sufficient shaking in Andresen's experiments and may be due in part to Andresen's solutions not being sufficiently alkaline.

4. In strongly alkaline solutions and with silver bromide in excess, the silver equivalent of hydroquinone is about 6 for short runs and about 8 for long runs, at room temperature. At 100° the silver equivalent is at least 9 for short runs.

5. The silver equivalent for quinone is about 2 less than for hydroquinone. Quinone is unquestionably an intermediate product when hydroquinone reacts with silver bromide in absence of sodium sulphite.

6. In strongly alkaline solutions and with excess of silver bromide, the silver equivalent of hydroquinone is something over 8 in presence of sodium sulphite for short runs and about 9 for long runs.

7. The increase of 2 in the silver equivalent of hydroquinone, on short runs in presence of sodium sulphite, has been shown to be due to the fact that one mol of sodium sulphite is oxidized simultaneously with one mol of hydroquinone.

8. The apparent increase of only 1 in the silver equivalent of hydroquinone, on long runs in presence of sodium sulphite, is undoubtedly due to the formation of different oxidation products of hydroquinone in presence of sodium sulphite. This view is confirmed by the different color of the solution; but has not been tested analytically.

9. On short runs sodium sulphite increases the silver equivalent of hydroquinone by 2 if added before the run; by about 1 if added 5 minutes after the run has begun and by practically nothing if added 15 minutes before the end of a three-hour run.

10. On short runs sodium sulphite increases the silver equivalent of quinone by 1.

11. When hydroquinone reacts with silver bromide in strongly alkaline solution in presence of sodium sulphite, we have a coupled or induced reaction, one-half mol of sodium sulphite being oxidized while hydroquinone oxidizes to quinone, and one-half mol of sodium sulphite being oxidized while one mol of quinone oxidizes to something else.

12. The fact that the silver equivalents do not always come out as integers is probably not due entirely to analytical errors. The oxidation undoubtedly takes place along two or more different lines and the sum of these reactions is all that

is measured. Theoretically, there is also an effect due to concentration.

13. With ammoniacal silver nitrate the silver equivalent of hydroquinone was nearly 7 for a five-minute run and for a two-day run. It was about 8 for an eight-day run.

14. With silver sulphite dissolved in sodium sulphite the silver equivalent of hydroquinone was about 8 for a five-minute run. No long run was made.

15. With silver oxide and caustic alkali the silver equivalent of hydroquinone was about 10.5 for a five-minute run and for a fifteen-hour run.

16. With silver bromide and with ammoniacal silver nitrate, the oxidation of hydroquinone appears to go in two stages, pretty rapidly up to a silver equivalent of over 6 and then slowly to a value of about 8.

17. With silver sulphite dissolved in sodium sulphite, the 6 stage is not detected under the conditions of the experiment, while with silver oxide a silver equivalent of 10.5 is obtained at once. It is probable that, by varying the temperature and the alkalinity, one could get a series of changes with silver oxide, perhaps beginning with 2, corresponding to the oxidation from hydroquinone to quinone.

18. In a one-hour run with silver bromide, a silver equivalent of a little over 3 was found for pyrogallol. Hurter and Driffield obtained a value of 4 when acting on ammoniacal silver nitrate.

19. Pyrocatechol has a silver equivalent of about 4.5 acting on silver bromide in absence of sulphite. Andresen found a silver equivalent of 2 for pyrocatechol when acting on silver bromide in presence of sodium sulphite. The discrepancy is either due to a difference in alkalinity or to experimental error in Andresen's determination.

20. In strongly alkaline solutions and with excess of silver bromide, addition of sodium sulphite increases the silver equivalent of pyrocatechol by about 1 and has apparently no effect on the silver equivalent of pyrogallol.

21. When quinone reacts with alkali, one of the reaction products is unquestionably hydroquinone. Mees and Shepard believe that the other product is hydrogen peroxide; but it is hard to reconcile this view with the fact of a definite silver equivalent. Luther and Leubner believe that the other product is oxyquinone; but they give no experimental evidence in support of this.

22. Luther and Leubner say that dioxyquinone is the final oxidation product when hydroquinone reacts with silver bromide in alkaline solution. They have not isolated the compound however.

23. The formation of dioxyquinone would account for a silver equivalent of 6 and consequently could not account for a value of 10.

24. The low values of the silver equivalent, obtained by Luther and Leubner are due to their working for short times with solutions containing potassium bromide and made alkaline with sodium carbonate.

25. The fact that the silver equivalent varies but slightly while the concentration of sodium sulphite varies very largely shows that Mees and Sheppard are wrong in believing that sodium sulphite regenerates hydroquinone in presence of a silver salt.

This work was suggested by Professor Bancroft and has been carried on under his supervision.

*Cornell University*

## NEW BOOKS

**Studies in Radioactivity.** By W. H. Bragg. 14 X 23 cm; pp. x + 196. New York: The Macmillan Company, 1912. Price: \$1.60.—In the preface the author says: "Certain general conclusions seem to me to follow from a comparative study of the three types of radiation, and I hope that I have made this appear from what I have written.

"In the first place, it is interesting to observe the absence of any evidence of true secondary radiation; that is to say, of any ionizing radiation which derives its energy from matter under the prompting of primary rays. That to which the name has been provisionally given draws its energy from the primary alone, and we can, up to the present, claim no power of causing the atoms to unlock and distribute any stores of energy which they may possess. This is not, of course, the first occasion on which the conclusion has been stated.

"Again, it is remarkable that there should be so little evidence of the influence of molecular association upon radioactive phenomena. When an atom acts upon a passing  $\alpha$  or  $\beta$  or  $\gamma$  ray, it is unsupported by any other atom, even of those belonging to the same molecule.

"It is impossible to avoid being struck by the strong family likeness which the three types of radiation,  $\alpha$ ,  $\beta$  and X or  $\gamma$ , rays, bear to each other. The  $\alpha$  rays are positively charged, the  $\beta$  rays negatively, the X and  $\gamma$  rays are uninfluenced by electric and magnetic fields. But, putting aside these differences and their immediate consequences, in their laws of penetration and of scattering, in their actions on matter and the reactions which they suffer themselves, the three forms of radiation differ in degree rather than in kind. If it is assumed that the action of each form is direct and requires no assistance from any other form, it is difficult to believe at the same time that the  $\alpha$  and  $\beta$  radiations are corpuscular, and that the X and  $\gamma$  rays are spreading pulses in the ether. The distinction in form is too great: the X and  $\gamma$  rays have corpuscular properties also.

"I believe, however, that the assumption is wrong: and that the X and  $\gamma$  rays act only through the intervention of  $\beta$  rays. This is accomplished by means of a complete interchangeability between the X or  $\gamma$  ray on one hand and the moving electron on the other, a change which may be brought about during the passage of the ray or the electron through the atom. This is one of the most striking of the general conclusions to which I have referred. It explains the great bulk of the X ray phenomena with readiness and simplicity, and, moreover, it bids fair to be useful in the still wider field of general radiation. I have tried to show that the interchange must take place with little loss of energy. Papers by R. Whiddington and C. T. R. Wilson, published so recently that I have been unable to refer to them in the book, accentuate still further the reality and importance of the conception and simplify it by showing that the transformations imply no loss of energy at all. Wilson's most recent photographs of the clouds formed on the tracks of ionizing agents are far better than those which I have been able to produce.

"The principle of interchangeability also leads at once to a corpuscular hypothesis of X and  $\gamma$  rays. The corpuscular idea correlates the main facts in a fashion which is convenient both for thought and for experiment. I think it is just to say that the aether pulse idea has been for some time unproductive. It is only by the aid of numerous and very special assumptions that it can be made to account, even to outward seeming, for the phenomena of the scattering and the absorption of X rays and the production of the secondary radiation. It seems to me better to put it aside provisionally and to take the interchangeability of X ray and electron as a new starting point. From this, fresh opportunities of advance in knowledge open out in all directions, and after all that is the one sufficient justification for any hypothesis. To take such a step is no denial of all connection between X rays and electromagnetic phenomena; it is but to put down one tool and to take up another better fitted for the moment to the work in hand."

The chapters are entitled: preliminary experiments; the range-finding apparatus; the ionization curve of the  $\alpha$  ray; interpretation of certain peculiarities of the  $\alpha$  ray curve; stopping power; the ionization produced by the  $\alpha$  particle in the different gases; initial recombination; the  $\beta$  ray and the law of its scattering; the loss of energy of the  $\beta$  ray; the general case of "absorption" of the  $\beta$  ray; general properties of the X and  $\gamma$  rays; the production of the secondary  $\beta$  ray by the X ray; the corpuscular form of the X ray; the energy of the X ray; calculation of the ionization current under given conditions; the scattering of X and  $\gamma$  rays; the nature of the X and  $\gamma$  rays. The following quotations, pp. 76, 108 and 134 will give some idea of the point of view:

"The  $\beta$  rays emitted by radioactive substances and the cathode rays of the vacuum tube consist, as is well known, of electrons moving at a high rate of speed. The  $\beta$  rays emitted by Ra C have initially a velocity little less than that of light: the majority of the  $\beta$  radiations have velocities somewhat smaller than those of Ra C. Cathode rays may have a great variety of velocity, being usually excited by the applied electromotive force to a speed of about  $10^9$  to  $10^{10}$  cm per second. Even electrons moving with still less speed, down to somewhere about  $10^8$  cm per second, may be classed as  $\beta$  rays.

"For all these rays have the common property of being able to ionize a gas through which they pass. The fastest have, of course, the greatest energy to spend, and they can penetrate two or three meters of air at ordinary temperature and pressure, ionizing some of the molecules through which they pass: the slowest are barely able to penetrate at all, and the limit of speed below which they are unable to show their presence by their ionizing effects is also the limit to their definition as  $\beta$  rays.

"There is no need to discuss here the determinations of the mass, charge and velocity of the various electrons from various sources. I may pass on at once to consider the effects attending their passage through matter. They may be taken in much the same order as that which I have adopted in considering the  $\alpha$  rays; and I shall be glad to follow this plan because it is one of my main objects to show that the phenomena of the  $\alpha$  and the  $\beta$  rays, and indeed also of the  $\gamma$  and X rays, run parallel to each other and may be classified according to the same system.



"The means by which the  $\beta$  rays are discovered to us are the same as in the case of the  $\alpha$  rays. They, like the latter, can ionize a gas, act on a photographic plate, and cause a screen to phosphoresce. It is therefore possible to map out the paths which the  $\beta$  rays take as a stream, but the effect of a simple  $\beta$  particle has been too feeble to follow until quite recently. Just as Rutherford and Geiger's scintillation method enabled them to follow the movement of the single  $\alpha$  ray, so now C. T. R. Wilson has made a similar advance in the case of the  $\beta$  ray. By a modification of his beautiful fog experiment he is able to render the track of the single  $\beta$  particle visible to the eye: his success is, however, so recent that few results are yet available."

"The aether pulse theory of the X and  $\gamma$  rays is based on the assumption that they consist of disturbances in the aether which spread away from places where electrons have received accelerations, positive or negative, of their motion. Stokes, Thomson, and other workers have attempted to mould the theory so that it will fit in with the properties outlined above.

"There remains, however, one striking phenomenon in connection with these rays, which we have not yet considered, and which was not, as we now see, taken into proper account by the authors of the pulse theory. This is the emission of swiftly moving electrons from matter through which the X or  $\gamma$  rays are passing. A very brief consideration of this effect will show its importance.

The swiftly moving electrons may have so great a speed that they can be ranked with the  $\beta$  rays, the properties of which we have already considered; we find speeds of this high order in the case of the electrons owing their motion to the  $\gamma$  rays. Or, again, they may be slower, having initial speeds varying between  $10^9$  and  $10^{10}$  cm per second. The electrons ejected under the influence of X rays have velocities of this order, and are generally called cathode rays, since these are the usual velocities of the cathode rays in the vacuum tube. But whether they are possessed of the greater or the lesser speeds they are all able to ionize a gas, to act on a photographic plate, and to excite phosphorescence in suitable materials, and it will be convenient to call them all  $\beta$  rays irrespective of the order of their velocity, in the same way as we have decided to use the term X rays to cover the  $\gamma$  ray also, unless, of course, there is reason to make a distinction.

"Now it is clear that if X rays produce  $\beta$  rays, and if the latter are able to cause ionization, phosphorescence, and photographic action, then there is no evidence, *a priori*, that the X rays themselves possess this power. It may be that the effects which we find in the presence of X rays are not due to the rays themselves directly, but to the  $\beta$  rays which they produce. This doubt would in any case prompt us to begin a thorough investigation of X ray phenomena by considering the circumstances in which the one kind of ray produces the other, and by examining the relations between the qualities and properties of the X rays on the one hand and on the other the speed of the  $\beta$  rays and the nature of the matter in which they arise. This we will now do. It will be seen later that we could have followed no other course, for the doubt turns out to be quite justified.

"The evidence which we shall consider goes to show that the X ray has no

direct action whatever except the one of causing the  $\beta$  ray. Only in this way does it reveal its existence. Up to the point when the  $\beta$  ray is produced the X ray spends no energy and causes no observable effect. After that point has been passed, the effects are those of the  $\beta$  ray, and as such have been considered already. There is left for the main object of our consideration the moment of the production of the  $\beta$  ray. This is an anticipation, and I have inserted it with the object of making it easier to keep in mind the arguments that follow. For the same reason, it may be well to add that this method of procedure does not lead immediately to the aether pulse theory. This theory, as I have already said, was formed at an earlier stage with the object of explaining the first found properties of the rays—their penetration, their lack of reflection, refraction, and so on. But it does not give a ready account of the circumstances peculiar to the production of  $\beta$  rays: and if it is on these that attention should be concentrated, if there is really little else to consider as the direct result of X ray action, then a theory which does not take them seriously into account is not immediately helpful."

"The speed of the  $\beta$  ray due to the  $\gamma$  or X ray depends only on the quality or penetrating power of the exciting ray. The speed and penetration of the former increase with the penetration of the latter. The speed depends neither on the intensity of the  $\gamma$  or X ray stream, nor upon the nature of the atom in which the  $\beta$  ray arises.

"The initial direction of the movement of the  $\beta$  ray is more or less in continuation of that of the  $\gamma$  or X ray, this effect being most pronounced when the exciting ray is penetrating and the atomic weight small. In the case of hard  $\gamma$  rays and light atoms, the continuance is almost complete; in the case of soft X rays and heavy atoms, it is very small." Wilder D. Bancroft

*Dictionary of Applied Chemistry.* By T. E. Thorpe, 2nd Ed., Vol. II. 15 X 23 cm; 786 pp. Price: 45 shillings. New York: Longmans, Green & Co., 1912.—This volume begins with china red and ends with gorse. Among the interesting items are: China grass, chloral, chlorine, chloroform, chromium, chromophores, cider, citric acid, clay, cobalt, cochineal, cocoa, coffee, coke, colloids, copper, corrosion, creosote, cryoscopy, cyanides, desiccation, diamond, diazo-compounds, diffusion, disinfectants, distillation, dyeing, egg, electro-decomposition, enamel, esterification, evaporation, explosion of gaseous mixtures, explosives, extraction apparatus, feeding stuffs, fermentation, fertilizers, filter pumps, filtration, flame, fluorine, formaldehyde, fritts, fuel, furnaces for general laboratory use, fusel oil, gas, gas mantles, glass, glucosides, glue, gluten, glycerine, and gold. Emulsions are missing, but that is about all.

The following extracts from the articles on colloids, p. 113, flame, p. 568, and glass, p. 737, will give some idea of the method of treatment, of the thoroughness, and of the accuracy, besides being interesting in themselves.

"At the present time, the term 'colloid' is used in a sense somewhat different from that in which Graham employed it, and is to be interpreted as referring, not so much to a particular class of substances, as to a condition which a large number of chemical compounds may be made to assume. A 'colloidal solution,' therefore, is not necessarily a solution of a colloid (in Graham's sense);

it is a solution, the properties of which are, in many respects, similar to those of, say, a gum arabic solution, although the dissolved substance may be quite outside the class which Graham terms 'colloids'; it may be, for instance, ferric hydroxide, arsenious sulphide, or platinum."

"When solids and liquids are heated beyond a certain temperature by an external source of heat, they become luminous, and the intensity of the light emitted increases very rapidly as the temperature is further increased. There is no reason to suppose that gases would behave differently except in degree, for, according to the kinetic molecular theory of matter, light should arise from molecular vibrations occasioned by molecular collisions. It is doubtful, however—whatever may be the case in celestial bodies—whether a gas has ever been brought by artifice into what may be called a state of purely thermal glow. The high transparency of gases to light is correlative to a very low emissivity. Iodine vapor, which is an exceptional gas in its absorptive power, does indeed glow when heated in a glass tube even when the walls are considerably below a red heat; but there is reason to believe that this glow is connected with the dissociation and recombination of the atoms in the iodine molecule.

"Attempts to heat colorless gases, such as nitrogen, to the glowing point, have given negative results. In almost every case, a flame is glowing gas, and in view of the facts just recited we must add the qualification, so far as terrestrial conditions are concerned, that the glow is the accompaniment of chemical change. It would be possible to refine upon this definition. A 'flame' of pure hydrogen in dustless air is invisible according to Stas, the radiation of short wave lengths being wholly in the ultraviolet. Again, the glow observed during the decomposition of acetylene in a hot tube may be due wholly to the particles of liberated carbon and in no degree to anything gaseous. But, speaking generally, the basis of flame is a glowing gas, and the exciting cause chemical action. This description would include ordinary hot flames and also flames of the kind called phosphorescent, which may be quite cold in the ordinary sense of the word."

"The Siemens process [of hardening glass] depends on the principle that glass, if evenly cooled, however quickly, is under little strain, and that the more rapidly it loses its heat the harder its surface becomes. A sheet of glass, for example, loses heat more rapidly from its edges than from its surface, owing to the greater surface exposed. Hence it is under strain. But if the heat is rapidly and uniformly conveyed away from the surface, it retains its shape, and is hardened and not under strain. The cooling should be proportional to the volume of the glass, not to its surface. The glass, which must be without flaw, is exposed suddenly and evenly to the radiant heat of a special furnace. The plate is then withdrawn and placed quickly between metal plates. The process of heating requires one minute and the cooling half a minute. The sole of the heating furnace is smooth, and is covered with powdered talc to prevent the adhesion of the glass. The success of the process is due to the uniform temperature of the furnace, and to the fact that the heat is wholly radiant. Owing to the extremely high temperature to which the plate is exposed, hard enamels may be used for ornamenting its surface. If required of extreme hardness, thin copper plates are applied to cool it. Iron plates give a less hard

glass; and the effect may be reduced by covering the surface of the cooling plates with wire gauze, or by using asbestos paper or clay slabs. Bottles may also be hardened by heating them until soft, and then placing them in a case of iron in which they stand, prevented from touching the iron in more than three places by projecting ribs, or they may be heated in the casing, and then removed from the furnace and allowed to cool in the air. The most quickly cooled of such plates withstand eight times a shock which would break an ordinary plate, and those slowly cooled or semi-hardened, three times. They are not scratched by a diamond, and hence cannot be cut; but they may be polished, etched, and slightly ground if desired."

Wilder D. Bancroft

*Spectroscopy.* By E. C. C. Baly. 2nd Ed., 13 × 19 cm; 687 pp. New York: Longmans, Green & Co., 1912. Price: 12/6.—In the preface to this edition, the author says:

"Since the first edition of this book appeared there have been published a very great number of papers describing most important investigations in spectroscopy. The advance in this subject during the last six or seven years has been exceptionally great, and I have found it exceedingly difficult satisfactorily to deal with this work and still to keep the book within reasonable limits. Even with the increase in size I cannot but feel that I have done scant justice to most valuable and striking investigations. I have endeavored, however, as far as possible to give a *résumé* of the salient points of the more modern work, and I have also ventured to add at the end of the relevant chapters a list of references to the literature which I trust may be of value to those who wish to read up the various subjects in greater detail than I have been able to include in the text."

The subject is presented under the following heads: historical; the slit, prisms, and lenses; the complete prism spectroscope; the prism spectroscope in practice; the diffraction grating; the ruled grating in practice; the extreme infra-red and ultraviolet regions of the spectrum; the applications of interference methods to spectroscopy; the practical resolving power of the spectroscope; the photography of the spectrum; methods of illumination; phosphorescence and fluorescence; absorption spectra; the nature of spectra; the Zeeman effect; series of lines in spectra; change of wave length.

Different people will get different things out of the book. The reviewer has been especially interested in: the metallic reflection of quartz for certain heat rays, p. 262; Abney's emulsion which was blue by transmitted light, p. 368; the flame spectra of salts, p. 384; the "ultimate rays," p. 405; the streamers in an oscillatory discharge, p. 411; the problem of the spark spectrum, p. 420; the electrical evaporation of electrodes in pure argon, etc., p. 431; the direct current discharge with a lime cathode, p. 437; the plurality of spectra, p. 518; the Swan spectrum, p. 523; and the two hydrogen spectra, p. 525.

The author has an interesting theory in regard to absorption spectra, p. 487 and to emission spectra, p. 495.

"Perhaps the most important fact that must be taken into consideration is the very profound influence that the solvent has upon the absorption of various substances. A moment's consideration of this influence of the solvent will

show that some account must be taken of the residual affinities of the two, solvent and substance dissolved.

"Now, if the chemical properties of substances be considered it will be quite evident that every atom or group of atoms in a compound must possess residual affinity to a greater or a less extent, if under residual affinity we include every type of unsaturation whether as regards the primary or secondary valencies. Generally speaking, in chemistry we say that a compound is unsaturated when one or more of the principal or ordinary valencies is unsatisfied, as, for example, in those cases when we write a double bond. Such compounds as these have the property of forming addition compounds with other substances and so they must possess residual affinity. In addition to this special type of residual affinity we have also the cases of compounds which, though apparently perfectly saturated as regards their principal valencies, yet indeed form double and complex compounds with other substances. It is generally accepted that these properties are due to the so-called contra-valencies. Every atom possesses these contra-valencies developed to a certain extent, and so, if under the term residual affinity be grouped every type of unsaturation, it will follow that every atom or group of atoms must possess this residual affinity to a greater or less amount.

"Since the possession of residual affinity tends to endow a compound with the power of forming addition compounds with other substances it may be said that the existence of residual affinity is accompanied by the existence of force lines in the surrounding ether. Every atom or group of atoms must be the center of a field of force in the ether, the strength of which depends upon the amount of the residual affinity present in each case.

"The independent existence of these various fields of force round about one molecule is manifestly impossible, such a condition must be metastable. There must ensue a certain amount of condensing together of the force lines accompanied by the escape of free energy. The resulting condensed system must have a decreased chemical reactivity compared with the original metastable condition. In fact, if the system be entirely closed it will have no chemical reactivity at all, and it is only when the closed system is unlocked that it can show any chemical reactivity. It does not necessarily follow that although the condensing together of the force lines must occur, the resulting system is entirely closed. The system may still possess some small residue of reactivity which, however, in any case will be very much smaller than that of the metastable uncondensed form. Generally speaking, it follows that in order that a compound exert its true reactivity it must be unlocked, so to speak, by some external means.

"Now, one way of opening up such a condensed system would be to supply free energy to it. Again, it is a well-known fact that certain reactions are catalyzed by the action of light as, for example, the union of hydrogen and chlorine. Before the hydrogen and chlorine molecules can react upon one another it is necessary that their closed systems be opened up, and it would seem that this opening up can be effected by means of the influence of the light rays. The light rays must therefore be doing work against chemical forces.

"This at once gives a rational explanation of the absorption of light by substances, namely, that the light is doing work against the chemical forces

which tend to produce the closed systems, and that the necessary free energy is supplied in this way."

"Now it is perfectly evident that the various stages in the unlocking process must be closely connected together, and it may at once be assumed, in the event of the unlocking taking place in stages, that the second stage will not take place until the first stage is complete, and that, in general, each successive stage will not begin unless the previous stage is complete. The result of this may perhaps be understood more clearly from the following: let A represent the completely closed system of a complex molecule, and B, C, D, etc., the several stages in the opening up of this system. Further, let A, under the influence of a suitable solvent and of light, be opened up into B, and let the wave length of the light required be  $\lambda_B$ . Now let A be opened up to C by means of a second solvent, and light of wave length  $\lambda_C$ . Then, as far as experiment has shown at present,  $\lambda_C$  is greater than  $\lambda_B$ . Since the opening of A into the form C is brought about by the absorption of light of wave length  $\lambda_C$ , so the converse must be true, namely, that the condensing together of the system C to give the system A must be attended by the evolution of light of wave length  $\lambda_C$ . Now, if by any means the form A be converted into the form B, which results in the complete opening up of a portion of the system, it would seem naturally to follow, as a result of the fact that B and C are intimately connected, that B cannot return to A without influencing in some way the force lines of the whole system. It is not possible to conceive of a portion of a closely interwoven locked system being opened without the whole system being affected. The partial opening of the system to give the condition B must affect the whole. The next possible system under the conditions of the experiment is that which we have called C. The restoration of the system, as disturbed by the influence of the light rays, does not seem possible without a disturbance brought into play which involves the system C. Now, it has already been shown that the process  $C \rightarrow A$  must be accompanied by the evolution of light of wave length  $\lambda_C$ . It follows, therefore, that the restoration to the form A from the form B must involve the form C, with evolution of light of wave length  $\lambda_C$ ; and as it has been shown that A is converted to B by the influence of light of wave length  $\lambda_B$  in an appropriate solvent, so this absorption of light  $\lambda_B$  must be accompanied by the evolution of the rays  $\lambda_C$ . In other words, the substance fluoresces. It may be pointed out at once that the form C may not be the only one concerned; it is quite possible that the successive forms D, R, etc., may be brought into play, each giving out light of characteristic wave length, always provided that the several forms are all intimately connected under the experimental conditions as postulated above.

"It is perfectly possible to subject this theory to practical test. It is evident that if the process  $C \rightarrow A$  gives out light of wave length  $\lambda_C$ , A should, in the presence of a suitable solvent, be converted into C by absorption of this light  $\lambda_C$ . In other words, it should be quite possible, by the use of an appropriate solvent, to influence a substance so that it absorbs light of the same wave lengths as the fluorescent light it emits in another solvent. This close relation between fluorescence and absorption has been found in several cases. Dr. Krulla, working in my laboratory, examined, among others, the cases of the amino-aldehydes and ketones mentioned above, and finds that these substances in

alcoholic solution emit, under the influence of ultraviolet light, fluorescent light of the same wave length as those rays absorbed by the compounds in presence of small traces of hydrochloric acid. These results afford considerable support to the theory."  
Wilder D. Bancroft

**A Laboratory Outline of Organic Chemistry.** By Lauder W. Jones. 12 × 18 cm; pp. viii + 191. New York: The Century Company, 1911.—In the preface the author says:

"In most institutions of learning there has grown up an increasing demand for more intensive as well as extensive training in elementary chemistry; and this has brought about corresponding changes in the curriculum of chemistry. Experimental organic chemistry, once a mature part of the course, usually preceded by qualitative and quantitative analysis, and requiring a reading knowledge of German and French, now finds itself stranded with general inorganic chemistry as its sole prerequisite.

"The majority of laboratory outlines of organic chemistry, although for the most part excellent, are designed primarily for the mature student in chemistry who is able to read and to digest the original articles cited for reference; and for those who are concerned more especially with varied manipulation and method rather than with a systematic study of the salient facts and relations underlying the science. On the other hand, the few briefer and simpler outlines extant can hardly be regarded as adequate to give the kind of preparatory training which is now being sought in many quarters.

"It would seem, therefore, that there is a place for a text-book which shall approach the subject matter of organic chemistry in much the same thorough but elementary fashion that we are wont to employ in laboratory manuals of inorganic chemistry. In other words, there is need of a course in general organic chemistry. It is hoped that this book may occupy a position and supply a need of this character."

It seems to the reviewer rather questionable whether a student should take laboratory work in organic chemistry before he has had either qualitative analysis or quantitative analysis. However, the book can be considered apart from the preface. The preparations are arranged as aliphatic and aromatic compounds. Under the aliphatic compounds the two divisions are into monatomic and polyatomic compounds. The reviewer could not find any statement in the book as to the difference between a monatomic and a polyatomic compound. Under aromatic compounds the two divisions are into carbocyclic compounds and heterocyclic compounds. This is not the laboratory manual which the reviewer always hopes to find and always hopes in vain. The ideal manual will lay great stress on the theory of yields, a point which is practically ignored in all existing manuals. While this manual is not that manual, the basis of comparison is with existing manuals and not with those which apparently will not be published much before the millennium.

Looked at from this point of view, this book stands the test pretty well. The reviewer was delighted to see some experiments on colloids, though it is something of a puzzle to see how colloidal ferric hydroxide happens to come in under polyatomic organic compounds. Incidentally, it may be added that



Wright's method of making colloidal ferric hydroxide is quicker than any method involving dialysis. The manual also contains a number of experiments on dyeing which is a good thing; but they are scattered, which is a pity. We find azo dyes in one chapter, p. 99; diphenylamine dyes in another, p. 102; fast green in a third, p. 114; though not as an experiment. The triphenylmethane dyes occur in still another chapter, p. 119; and this is followed by a special chapter on dyeing, p. 122. It seems to the reviewer that it would have been better to have put all the experiments in this special chapter. Merely as a minor point, the reviewer doubts the ability of a student to get all the methylene blue out of cotton by rinsing for any reasonable number of times.

An interesting experiment, not usually found in organic manuals, is the one, p. 28, in which formaldehyde and silver nitrate are arranged to form a voltaic cell. If this manual is really to be used by students who have not had qualitative or quantitative analysis, the reviewer suggests that the experiments on methyl orange, p. 99, and phenolphthaleine, p. 120, be supplemented by one in which the student titrates phosphoric acid first with one and then with the other of these two substances as an indicator. *Wilder D. Bancroft*

*Die Dreifarbenphotographie.* By Arthur Freiherrn von Hübl. 15 × 22 cm; pp. viii + 212. Halle a/S: Wilhelm Knapp, 1912. Price: 8 marks.—The subject is treated under the main headings: light and color; theory and practice of three-color photography. Under the former we have the subdivisions, colored light and body colors; and under the latter the subdivisions, theoretical basis, plate sensitizing and light filters, practice of three-color printing. The book deals only with the methods of three-color photography, which involve taking three separate negatives and the production of actual images. The second limitation rules out the Ives chromoscope.

There is a very clear exposition of the Young and Helmholtz, and the Hering color theories. Very interesting also is the account, p. 75, of the colors which can be obtained by superposing gelatine films, dyed with erythrosine, patent blue, and filter yellow. There is quite a full discussion, p. 116, of color sensitizers. The reviewer was also interested in the statement that all films colored with red dyes absorb the green rays but often let the blue rays through as well as the red. It has been found that some red inks do not photograph well and the reason for this undoubtedly is that the paper under the ink reflects back enough blue light so that it photographs nearly the same as the adjacent paper on which there is no ink. The light which is cut out is light to which the photographic plate is not very sensitive. On p. 141 are given data for making red, blue and green filters from suitable mixtures of rose bengale, tartrazine, patent blue, and acid rhodamine.

There is much in the book which will interest people who are not directly concerned with three-color printing. *Wilder D. Bancroft*

#### ERRATA.

In Mr. Garver's article, 16, 679 (1912) equation (A) should have been printed

$$\frac{\gamma}{2t} = \rho \frac{R}{m} T \quad \text{and not} \quad \frac{\gamma}{2t} = \rho \frac{R}{m} \tau$$



THE PHOTOGRAPHIC PLATE. IX

BY WILDER D. BANCROFT

THE LATENT IMAGE. PART V

Latent Image is not a Physical Modification



With a short exposure to light we get a latent image which develops to a negative; with a longer exposure we get a latent image which develops to a positive. Namias<sup>1</sup> has shown that the action of light can be duplicated by the action of a stannous chloride solution.

"When I experimented to see how the same substance [stannous chloride] acted towards silver salts in developing the latent image, I found that its effect was quite marked. In fact a 1 : 20000 solution of crystallized stannous chloride,  $\text{SnCl}_2 \cdot 2\text{H}_2\text{O}$ , in distilled water, completely free from air, will produce in a few minutes' action on a silver bromide plate a latent action which can be detected by developing with an ordinary developer. The action of stannous chloride seems to be exactly analogous to that of light.

"If one allows a sufficiently concentrated solution (1 percent for instance) to act for an instant, or a more dilute solution to act for a longer time, one obtains a latent image which develops with great sharpness. If the action of the stannous chloride lasts too long, one gets a result analogous to that caused by over-exposure; the plate fogs and there is no sharpness. This is the result, for instance, if the 1 percent solution is allowed to act for 2 or 3 minutes. If the solution is allowed to act longer, it causes a visible change just as light does."

Perley<sup>2</sup> confirmed the results of Namias and extended them. He used solutions of stannous chloride of varying strengths in which he immersed unexposed plates for a con-

<sup>1</sup> Based on a paper read before the Eighth International Congress of Applied Chemistry in New York, September, 1912.

<sup>2</sup> Phot. Correspondenz, 42, 155 (1907); Jour. Phys. Chem., 15, 326 (1911).

<sup>3</sup> Jour. Phys. Chem., 14, 685 (1910).

stant length of time, using a standard developer. Up to a certain concentration he obtained increasing density of the developed plate with increasing concentration of the stannous chloride. Beyond this point, increasing the concentration within certain limits decreased the density of the plate. This corresponded to the case of solarization with a plate exposed to light. A similar result was obtained by using a stannous chloride solution of constant composition and immersing different portions of the plate for different lengths of time. A plate after undergoing this treatment was fixed and mounted as a lantern slide. At the same time another plate was exposed by sections to outdoor light in such a manner that the stages from the initial negative to the second negative would be produced. These two slides were retained in order to show the close analogy between the action of light and of a stannous chloride solution. With stannous chloride the various stages were far from being perfect analogies but the general principle was distinctly evident. The only really imperfect feature is that of the second negative. This is not as dense as that obtained by the action of light for an extremely long period. The second negative produced by stannous chloride is more of a brown than a black. This is not surprising because it is known that the color of the developed image varies with the nature of the developer and there is no reason why the difference in the preliminary treatment should not also have an effect. This is shown to be the case by Perley's results when he substituted a 10 percent sodium arsenite solution for the stannous chloride solution. The same general results were obtained but the second negative was black rather than brown. A latent image corresponding to a negative and one corresponding to a positive were obtained by Perley, using a mixture of ferrous and ferric oxalates instead of the stannous chloride solution. A similar result was also obtained by using a regular metol and pyrogallol developer<sup>1</sup> diluted to one-fourth. Owing to different rates of diffusion the results

---

<sup>1</sup> Eder: *Eder's Jahrbuch der Photographie*, 21, 475 (1907).

obtained at first were not as good as those with sodium arsenite or stannous chloride. By soaking the plate in the solution of metol, pyrogallol, and citric acid, and then adding the solution of acetone and sodium sulphite, the irregularities were eliminated. It is thus clear that the action of light can be duplicated qualitatively by the action of a solution of any reducing agent having a suitable reducing power. Consequently the latent image must consist of some reduction product of silver bromide and cannot be a physical modification of silver bromide.

#### **Latent Image is not Free Metallic Silver**

The latent image cannot consist of a nucleus of metallic silver because the latent image does not show the chemical reactions of metallic silver, because it does not show the electrical potential of metallic silver, and because this hypothesis cannot well be reconciled with the ordinary facts of development and cannot be reconciled at all with the facts of solarization.

Lüppo-Cramer's experiments with nitric acid bring out clearly that the latent image does not behave like a mixture of silver bromide and metallic silver.<sup>1</sup>

"In order to test the action of nitric acid on a collodion emulsion, I started with a dilute acid (12.5 percent  $\text{HNO}_3$ ). The plates were moistened with water, bathed for 1 minute in the acid, and then washed thoroughly. One plate was exposed before the treatment with nitric acid, one after treatment with acid, while a third plate was exposed and not treated with acid. The plate which was bathed in nitric acid before the exposure gave exactly the same image as the plate which was not dipped in acid at all. In the case of the plate dipped in acid after exposure to light, only the high lights and some of the half tones came out. The image was like the one that would be obtained by one-fourth the exposure.

<sup>1</sup> Lüppo-Cramer: *Phot. Correspondenz*, 38, 145 (1901); *Jour. Phys. Chem.*, 15, 571 (1911).

"When an acid containing 33 percent  $\text{HNO}_3$  was used, the plate which was exposed after the treatment with acid gave the same results as the check plate. The one treated with the acid after the exposure gave only a slight precipitate in the high lights. Nitric acid of this concentration dissolves the fine-grained silver of a Lippmann photochrome rapidly but not the precipitate in a collodion process negative. It was necessary therefore to play the last trump and to use concentrated nitric acid (sp. gr. 1.4) containing 65 percent  $\text{HNO}_3$ . This acid attacked the collodion along the edges and the latent image disappeared completely. The plate which was exposed after the treatment with acid gave nearly, though not quite, as strong an image as that on the check plate."

Lüppo-Cramer uses these experiments to show that the latent image can be destroyed by a sufficiently concentrated nitric acid and that therefore one cannot postulate a silver subbromide insoluble in nitric acid. That is reasonable enough as an argument against Eder; but it does not affect me because I have no wish to postulate any silver subbromide at all. The experiments do show that the latent image is much less readily attacked by nitric acid than is the case with ordinary metallic silver.

Heyer's experiments<sup>1</sup> with silver chloride containing no binder gave similar results. "Heyer prepared subchloride by Guntz's method, heating silver subfluoride with phosphorus trichloride in a sealed tube to  $140^\circ$ . He tried to find a characteristic reaction which would distinguish between the subchloride and a mixture of silver and silver chloride in the molecular ratio of one to one. The nearest that he came to one was that nitric acid at first dissolves the excess of silver readily from Guntz's subchloride whereas strong nitric acid (sp. gr. 1.2) does not dissolve any silver when the excess of silver over that required for silver chloride has been reduced to 1 to 2 percent. The specific gravity of Guntz's subchloride

<sup>1</sup> Weisz: *Zeit. phys. Chem.*, 54, 316 (1906); *Jour. Phys. Chem.*, 15, 559 (1911).

(6.76) is very close to that of a molecular mixture of silver and silver chloride (6.91)."

This experiment is also a failure as regards any attempt to prove the existence of a hypothetical subchloride; but it is pretty conclusive as to the absence of free metallic silver when the excess of silver over silver chloride becomes small. The discrepancy in the two specific gravities may well be a real one if we assume adsorbed silver. Weisz<sup>1</sup> apparently feels much the same way about it.

"The agreement between the observations of Heyer and of Baur is of importance for the question of the latent image. Heyer found that the last one or 2 percent of the excess of silver in Guntz's subchloride is only removed very slowly even by strong nitric acid. Baur noticed the same thing with his photochloride plates. This is in accord: with the observations of Carey Lea; with the usual statement that the latent image is not destroyed by nitric acid; and with my own experiments on plates containing no binder. I found that the visible blackening and the latent image are not changed by being soaked for an hour in nitric acid (sp. gr. 1.4); also that there is no sign of any bleaching when the plates are left for five weeks in a solution containing 20 percent ammonia iron alum, 20 cc conc. H<sub>2</sub>SO<sub>4</sub> per 100 cc solution, and a trace of silver as ion. This confirms the earlier experiments of Luther and contradicts a statement by Wetzlar to the effect that the bleaching is complete under these circumstances."

Chapman Jones<sup>2</sup> cites the behavior of the latent image with ammonia to prove that the latent image is neither metallic silver nor a subbromide. For the moment we are chiefly interested in the first conclusion; but we shall endorse the second one later.

"One of the most direct pieces of evidence against the decomposition hypothesis is furnished by the action of a solution of ammonia. This reagent, it is admitted, decomposes

<sup>1</sup> *Zeit. phys. Chem.*, 34, 319 (1910); *Jour. Phys. Chem.*, 15, 561 (1911).

<sup>2</sup> "Science and Practice of Photography," 384 (1904); *Jour. Phys. Chem.*, 15, 342 (1911).

silver subbromide, leaving half the silver as metal. Therefore, taking cognizance of this reaction only, the application of ammonia to the plate first in development ought approximately to halve the speed of the plate, because the amount of the metallic silver produced by its action would be one-half the quantity produced by the initial action of the developer, which, according to the theory, reduces the subbromide entirely. Or, if the speed of the plate is not so much affected, certainly development should be retarded by the previous application of the ammonia, because it would give only half the amount of metallic silver to start with. But, as a matter of fact, applying the ammonia first, rather quickens development, and tends to increase the apparent sensitiveness of the plate.

"An ordinary solution of ammonia is a good solvent for finely-divided silver, the oxygen of the air dissolved in it taking part in the reaction. The previous application of ammonia should, therefore, not only straightway halve the amount of metallic silver that would otherwise be available, but at once begin to get rid of the other half by dissolving it. As the largest possible amount of silver is exceedingly minute, thousands of times smaller than the smallest quantity directly detectable, and so finely-divided, withal, as to be invisible, the ammonia should dispose of it quickly. Now the effects of the ammonia are not imaginary effects; they can easily be verified. But as a matter of fact, ammonia facilitates development. Ammonia does not act on the developable image as it does act on silver subbromide. This, therefore, is evidence that the developable image does not consist of silver subbromide." Since ammonia does not act on the developable image as it does on free metallic silver, it is evident that the developable image does not consist of free metallic silver.

The conclusions of Chapman Jones are not justifiable in so far as they relate to speed of development. He is postulating that the only action of ammonia is a solvent one whereas the presence of the ammonia makes the subsequent de-



veloper more alkaline and therefore increases the rate of development. He has also omitted any reference to the solvent action of ammonia on silver bromide, probably considering that this would also cut down the rate of development. This hypothetical conclusion is undoubtedly erroneous; but a discussion of this point belongs under the theory of developers and therefore cannot be taken up now. Chapman Jones is right, however, in pointing out that the ammonia would dissolve that amount of silver if it were present as free metallic silver.

There is an interesting false conclusion in one of Lüppo-Cramer's papers.<sup>1</sup>

"It is quite unnecessary to make hypotheses in regard to the latent image because there is no reason to suppose that we have anything but silver bromide. Silver bromide was precipitated from aqueous solution with an excess of bromide. It was spread out in a flat dish and exposed to diffused light for 3 hours, during which time it was kept moist with water and was stirred thoroughly so as to keep exposing a fresh surface. The silver bromide became grayish violet in color, and bromine could be detected in the water by the smell or by the reaction with silver nitrate. When the darkened silver bromide was heated with concentrated nitric acid, no silver was dissolved and the color did not change appreciably. The decomposition product of the silver bromide was not completely soluble in thiosulphate. Although most of it dissolved, the solution was turbid and grayish blue by transmitted light, which indicated the presence of suspended silver. These reactions show that some bromine is set free during a long exposure to light.

"If we study carefully the action of light on precipitated silver bromide, we notice that there is a visible color change in a very short time. The silver bromide changes in a few seconds from the original greenish yellow to a green which

<sup>1</sup> Lüppo-Cramer: *Phot. Correspondenz*, 38, 222 (1891); *Jour. Phys. Chem.*, 15, 577 (1911).

passes into a greenish gray. When silver bromide has only changed to this extent no bromine can be detected in the water and the silver bromide dissolves completely in thiosulphate. From this it appears to follow that a setting free of the bromine occurs only after a very long exposure, although light can cause in a very short time a change which can be recognized by the color passing through a series of shades."

The inability to dissolve any silver from the silver bromide, which had been acted on by light for a long time, is due to experimental error, to not using a sufficiently concentrated nitric acid. This was recognized by Lüppo-Cramer in the paper published ten years later. The conclusion that a soluble bromide should be found in the water when silver bromide was exposed to light for a short time rests on the tacit assumption that there is no adsorption by the silver bromide. This assumption was a perfectly legitimate one at the time Lüppo-Cramer wrote if we assume that he was not familiar then with the work of Carey Lea, but it is not permissible to-day. We know now that soluble bromides peptonize silver bromide<sup>1</sup> and are adsorbed by it. When the amount of silver bromide is very large relatively to the amount of soluble bromide, it will be almost impossible to detect this latter in the water. Lüppo-Cramer considers that no decomposition takes place because on short exposure the discolored silver bromide dissolved completely in thiosulphate. There are possible sources of error here. Since Lüppo-Cramer, on his own showing, did not wash the adsorbed hydrobromic acid out of the decomposed silver bromide, the bromide may have reacted with the silver as the silver bromide dissolved. A more plausible explanation is that the dissolved silver bromide did not dissolve completely in sodium thiosulphate; but that the colloidal silver left was not detected by Lüppo-Cramer. In 1891 that error might easily be made. Something of this sort must have taken place because Lüppo-Cramer has swung round since then to a belief in the fact of a

<sup>1</sup> Cf. *Jour. Phys. Chem.*, 14, 17 (1910); 16, 48 (1912).



decomposition when silver bromide is exposed to light and consequently he himself postulates some error in these experiments.

Though the quantitative experiments on the electrical potential of the silver halides are not very conclusive as to the nature of the phases, the difficulty of the measurements and the fact that no two people get quite the same values are conclusive evidence, to my mind at least, that we are dealing with something more than the two coexistent phases, silver and silver chloride. If those were the only possible phases, the measurements should be simple to make and it should be possible for anybody to reproduce the results.

We now come to the question of development in its bearing on the theory that the latent image consists of free metallic silver. Sheppard and Mees<sup>1</sup> find no great difficulty here.

"Proceeding from the fact that a 'germ' of metallic silver will induce the deposition of further silver upon it from a supersaturated solution, it provides the most satisfactory theory of development, but fails to account for the resistance of the 'latent image' to oxidizing solutions of such potential as to destroy metallic silver. It is also to some extent inconsistent with the initial induction in development."

A pertinent comment on this seems to be Lüppo-Cramer's statement<sup>2</sup> that "the fact that grainless silver will cause bromide in a collodion emulsion to be reduced by the developer is no proof that metallic silver is formed on exposure to light." Namias<sup>3</sup> goes much farther and refuses to admit that development can be accounted for on this hypothesis.

"In spite of the excellent reasons in support of this chemical theory [Abegg's silver nucleus theory], which is much superior to the one based on the assumption of the sub-bromide, it will not be accepted by everybody. Why should

<sup>1</sup> "Theory of the Photographic Process," 199 (1907); *Jour. Phys. Chem.*, 15, 551 (1911).

<sup>2</sup> *Jour. Phys. Chem.*, 15, 573 (1911).

<sup>3</sup> *Chimie Photographique*, 113 (1902); *Jour. Phys. Chem.*, 15, 352 (1911).

one admit that this infinitesimal quantity of metallic silver forms regularly throughout the whole depth<sup>1</sup> of the film to be developed? Why does the silver reduced by light exert an attraction on the silver bromide to be reduced in the developing bath only downwards through the film and not sideways from the points which have been exposed to light? We might make many other objections but there is always the difficulty of accounting for the way in which development takes place when we adopt any theory which presupposes an attraction. In order to be free from the objection just cited, any theory, molecular or chemical, must postulate that the change which makes the silver salt developable occurs in all the particles of silver salt exposed to light and not merely in a few of them."

The objections raised by Namias are not necessarily fatal. We might assume that the metallic silver acts as a nucleus only to the silver bromide grain from which it was set free, not being in actual contact with any other grain. We should have to supplement this, of course, by the further assumption that the rate of development was proportional to the surface of metallic silver exposed but that is just the assumption that is made explicitly. Since the extent of the silver surface grows very rapidly when the plate is developed with a so-called fast developer, I confess that it seems to me very difficult to account, on this hypothesis, for the delicate gradations that one actually gets. That, however, is, for the present, merely a matter of personal feeling and carries no weight as an argument against anybody who feels differently. On the other hand, it is quite impossible to account for the facts of solarization by this hypothesis. Longer exposure means more silver produced, though the amount may approach a limit. More metallic silver means more rapid reduction of the silver bromide grains and not less rapid reduction. This has led people to have recourse to the assumption of a rebromination of the silver under conditions which

---

<sup>1</sup> [This objection seems to me not to amount to anything. W. D. B.]

are not specified very clearly. This is not tenable, however, in view of the fact that the phenomena of solarization can be duplicated without the action of light, merely by letting a suitable reducing agent act for a longer time on the plate. Under these conditions there can be no rebromination of the hypothetical metallic silver and consequently there can be no decrease in the rate of development if the silver nucleus theory be correct. As a matter of fact there is a decrease in the rate of reduction and consequently the silver nucleus theory of the latent image is an impossible one.

#### Latent Image is not a Subhalide

While Luther's earlier experiments pointed to the existence of the definite compounds  $\text{Ag}_2\text{Cl}$  and  $\text{Ag}_2\text{Br}$ , the more recent work from the same laboratory<sup>1</sup> has shown their non-existence. Reinders<sup>2</sup> found no evidence of the existence of any stable compound of silver and silver chloride either at high or at low temperatures. The reactions of the latent image<sup>3</sup> are not consistent with the existence of a compound having the formula  $\text{Ag}_2\text{Br}$ . It is also impossible to account for the phenomena of solarization on the assumption of only one compound, no matter what composition or properties may be assigned to it. This has been admitted by Trivelli<sup>4</sup> who gets around the difficulty by postulating the existence of four compounds,  $\text{Ag}_8\text{Br}_7$ ,  $\text{Ag}_8\text{Br}_6$ ,  $\text{Ag}_8\text{Br}_5$  and  $\text{Ag}_8\text{Br}_4$ , the colors of these alleged compounds being green, blue, yellow and red, respectively. These alleged compounds have never been prepared in a state of purity and there is no satisfactory evidence as to their existence, and consequently we are justified in ignoring them and in concluding that the latent image is not a subhalide of definite composition.

Some of the criticisms of the subhalide theory made

<sup>1</sup> Heyer: Jour. Phys. Chem., 15, 557, 560 (1911).

<sup>2</sup> Zeit. phys. Chem., 77, 213 (1911).

<sup>3</sup> Cf. Jour. Phys. Chem., 15, 560 (1911).

<sup>4</sup> Cf. Lüppo-Cramer: Das latente Bild, 23 (1911).

by Chapman Jones<sup>1</sup> are unfounded, but some of them are worth discussing.

"The exceedingly minute amount of subbromide produced by ordinary exposure, according to the decomposition hypothesis, is allowed on all hands to be very, very far from sufficient to furnish by itself an image that can be seen or discovered in any way except by allowing it to grow. This growth, which means the reduction to the metallic state of the silver bromide that has not been affected by light by the indirect agency of that which has, is a necessary adjunct to the decomposition theory. The physical theory is complete in itself, and needs no supplementing. But the physical theory is in no way opposed to the fact that, under some conditions, the image spreads during development, unexposed silver salts being reduced to the metallic state. The demonstration that the image spreads in this manner, therefore, is no proof of the chemical theory, though it removes a difficulty which, if it existed, would at once condemn the decomposition hypothesis.

"But in a gelatine plate, it has never been proved that the image does grow more than an almost negligible amount (if at all), such, for example, as might interfere in the photographing of fine black lines. It is common experience that in the development of a gelatine plate a time comes when the 'development is complete,' 'the exposure effect is exhausted,' 'there is nothing more to get,' 'the density ceases to increase,' to quote a few common phases. If the whole image, except an indescribably small fraction of it, is the result of this growth or spreading, why should the growth of the image stop while the developer is still on the plate, instead of going on until the reduction of the silver salt is complete, and the plate is evenly black all over? It has been suggested that the growth cannot extend from granule to granule in the gelatine, but only from one part to another of the granule,

<sup>1</sup> "Science and Practice of Photography," 382 (1904); Jour. Phys. Chem., 15, 340 (1911).

so that only those granules that have been affected by light by the production in them of a few molecules of subbromide are amenable to development. This refinement of the chemical theory appears almost equal to the surrender of it. It formed no part of the original idea, and that the exigencies of the case should require such a suggestion is evident proof of the difficulty found in applying the chemical theory to the results of every day work.

“According to the decomposition hypothesis of the nature of the developable image, all that the developer has to do is to reduce the subbromide that is produced by the action of light to the metallic state, this silver by acting on unaltered bromide producing more subbromide, which is in turn reduced, and so on. The developer therefore simply reduces silver subbromide to the metallic state. This hypothesis obliges us to believe that there are some substances which can reduce silver bromide but cannot reduce the subbromide, or else these substances are of such a nature that the action of silver on silver bromide cannot take place in the presence of their solutions. The first suggestion seems exceedingly unlikely. With regard to the second, it is known that development is not hindered by ammonia or by a solution of ferrous citrate and ferrous oxalate, but, by mixing the two, the author has been unable to develop a developable image, although the silver salt was slowly and in the end copiously reduced. These difficulties and the need for the out-of-the-way suggestions do not exist if the physical theory is adopted. It is only what would be expected that some substances should be able to reduce the silver bromide that has been made less stable by the action of light without affecting the unchanged bromide, while other substances should be unable to discriminate between the altered and unaltered bromide. It is often the case that it requires much care to distinguish by chemical means between two different physical conditions of the same substances.

“If there is decomposition, that is, if the developable image consists of silver bromide that has lost a part of its

bromine, then, as the function of the developer is to remove bromine (leaving the image in metallic silver), exposure and development ought to be to a considerable extent interchangeable. But exposure and development are not interchangeable, for exposure beyond a certain point makes development impossible."

It seems to me quite unreasonable for Chapman Jones to object to the assumption that the growth does not normally extend from one grain to another. This is an assumption that must be made in every theory of the latent image. That it is a legitimate one for the upholder of any decomposition theory to make is shown by the difficulties which Lüppo-Cramer<sup>1</sup> encountered when trying to obtain reduction when metallic silver was kept in contact with silver bromide during the development.

"Although Lüppo-Cramer was not able to obtain a chemical development of a gelatine plate after adding silver nuclei, this fact was demonstrated by Weisz,<sup>2</sup> who showed that the important thing was to bring the silver particles in intimate contact with the silver bromide. He accomplished this by flowing the plate in a silver nitrate solution, letting it dry in the air, and by dipping it for a moment first into a ferrous sulphate solution and then into a sulphuric acid solution. By regulating the concentration, any desired amount of silver could be precipitated. Satisfactory results were obtained with solutions containing 1-2 grams  $\text{AgNO}_3$  per 100 cc and 8-10 grams  $\text{FeSO}_4 \cdot 7\text{H}_2\text{O}$  per 100 cc. It was also found that chemical development could be obtained when nuclei of gold, of platinum, or of silver sulphide were formed in the film in a similar manner. On the other hand, no chemical development could be obtained when a solution of colloidal platinum was poured over the plate. The simplest explanation seems to be that the platinum did not diffuse into the gelatine."

<sup>1</sup> Cf. *Jour. Phys. Chem.*, 15, 563, 579 (1911).

<sup>2</sup> *Zeit. phys. Chem.*, 54, 323 (1906).

The experiments of Lüppo-Cramer and of Weisz prove that the development does not spread from grain to grain even when the reduction is made possible only by the addition of metal. These experiments overthrow the contention of Chapman Jones, quite regardless of whether we assume that the added silver is effective as free metal, as hypothetical subhalide, or after being adsorbed in some form.

I do not know what Chapman Jones means by saying that the decomposition hypothesis "obliges us to assume that there are some substances that can reduce silver bromide but cannot reduce the subbromide." It is possible that this is a misprint for substances that can reduce the subbromide but cannot reduce the bromide. Whatever Chapman Jones may mean, he is wrong when he says that the suggestion is unlikely. There are many reducing agents which will reduce an alkaline cupric solution to cuprous oxide which will not reduce the cuprous oxide to metallic copper. There are also many reducing agents which will reduce acetaldehyde to ethyl alcohol but will not reduce acetic acid.<sup>1</sup> Whether it is easier to reduce silver bromide to subbromide or subbromide to metallic silver is a matter to be determined experimentally. It cannot be decided *a priori*. Of course Chapman Jones may have meant that whatever he meant was unlikely in view of other facts already known; but he certainly did not make himself clear.

It is also somewhat difficult to see what the trouble was with regard to development in presence of ammonia, ferrous citrate and ferrous oxalate. An alkaline ferrous solution is a very powerful reducing agent and could not be expected to show fine gradations. The slowness of development is probably a matter of diffusion.

The paragraph in regard to the interchangeability of light and development is full of inaccuracies. It is not fair to say that the action of light and the action of the developer must necessarily be interchangeable because both tend to

<sup>1</sup> Cf. Luther and Wilson: *Zeit. phys. Chem.*, 34, 488 (1900).

remove bromine from silver bromide. The upholders of the subhalide theory consider that the light reduces the silver bromide to a silver subhalide, while the action of the developer is, according to Chapman Jones himself, to reduce the subhalide to metallic silver, two entirely distinct reactions though both involving a removal of bromine. As a matter of fact, Perley's experiments<sup>1</sup> show that the action of light and of the developer are interchangeable provided the developer is made dilute enough so that its reducing power is equivalent to the reducing power of light. It is not true, as Chapman Jones stated, that "exposure beyond a certain point makes development impossible." What Chapman Jones means is that it is possible to select a certain exposure such that two intensities of light will affect the plate so that the two portions will develop of equal density. This is theoretically true only for one exposure and for any other exposure it will be possible to develop an image. Under ordinary conditions there may be quite a range of exposures over which the difference is not very marked, though even this is only true in case one uses the same developing solution in every case.

While the actual objections, raised by Chapman Jones, are not sound, there is one which he merely indicated and which is of importance. "According to the decomposition hypothesis of the nature of the developable image, all that the developer has to do is to reduce the subbromide that is produced by the action of light to the metallic state, this silver, by acting on unaltered bromide, producing more subbromide, which is in turn reduced and so on. The developer therefore simply reduces silver subbromide to the metallic state." To give the speed of development which one gets with a so-called fast developer, the reaction of metallic silver and silver bromide within the grain to form the hypothetical subhalide must take place very rapidly. If it takes place rapidly, there should be no difficulty in making and isolating the subhalide, and

---

<sup>1</sup> Perley: *Jour. Phys. Chem.*, 14, 685 (1910).



yet all the attempts to do this have failed. Consequently I conclude that the latent image does not consist of a definite subhalide. Another argument in favor of this conclusion is that prolonged action of light does not reduce a silver halide to a definite subhalide as it must do, were a second phase formed.

#### **Latent Image is a Case of Adsorption**

Since the latent image is a reduction product of the silver halide, since it is not free metallic silver, and since it is not a definite subhalide, the latent image must be a phase of variable composition with silver bromide as the end term. This view was first suggested by Carey Lea.<sup>1</sup>

"For more than a generation past, the nature of the latent photographic image, that which forms the basis of development, has been in dispute. Two theories have been maintained. According to the one, the first effect produced by light is simply a physical change, predisposing the elements of the silver haloid to dissociation, so that when a reducing agent is applied, the molecules so affected yield more quickly to its influence. According to the other theory, the invisible image is formed of a sub-salt (subchloride, etc.). Observations which I published many years ago led strongly to the first-mentioned of these theories. But of late years, results have been obtained not easily reconcilable with it. On the other hand, the theory that the latent image is formed of sub-salt is opposed to striking facts. Silver subchloride, for example, is an unstable substance, quickly destroyed by dilute nitric acid. But I have formed a latent image on silver chloride and after exposing it for 5 minutes to the action of strong nitric acid (sp. gr. 1.36) have developed the image without difficulty; the same with silver bromide. Evidently these images, which so strongly resisted the action of undiluted acid, could not be formed of simple subchloride and subbromide of silver, substances quickly destroyed by it.

"In the desire to find a satisfactory explanation of the

---

<sup>1</sup> Am. Jour. Sci., [3] 33, 349 (1887); Jour. Phys. Chem., 16, 29 (1912).

nature of the image based on adequate chemical proof, I have devoted nearly three years of laboratory work to this and to closely allied subjects. I am led to the conclusion that neither of the older views is correct. A truer theory seems to be deducible from the result of some experiments which I published in 1885, to the effect that the silver haloids were capable of uniting with certain other substances, much in the same way that alumina forms lakes. When a silver haloid was precipitated in the presence of certain coloring matters they combined with it, and though soluble in water, they could not be subsequently washed out. They had formed a somewhat stable compound, although the proportion of the coloring matter was very small in comparison with the haloid; evidently much too small to represent a stoichiometrical composition.

"Now I find that a silver haloid may in the same way unite with a certain proportion of its own sub-salt, which by this union quite loses its characteristic instability and forms a compound of great permanence.

"Another explanation is possible: the sub-salt may combine with the normal salt, not in the manner above described but in a stoichiometrical proportion, and this compound may be diffused through ordinary silver haloid. I have not been able to find any reaction decisive between these explanations, but the general behavior of the substance seems rather to indicate the first named explanation as the true one. When the red chloride, for example, has been boiled with dilute nitric acid for a few moments to eliminate any uncombined subchloride, the proportion of subchloride left has never exceeded 8 or 9 percent in over thirty specimens analyzed. If we took this to represent a compound in equivalent proportions, we should have to suppose the union of at least twenty equivalents of  $\text{AgCl}$  with one of  $\text{Ag}_2\text{Cl}$ , which is improbable. If we suppose that these colored substances containing less than 0.5 percent up to 8 or 9 percent of  $\text{Ag}_2\text{Cl}$  consist of a compound of one equivalent of subchloride united to a small number of equivalents of normal chloride, mixed

mechanically with a large quantity of normal chloride, then it would be improbable that specimens could not be obtained containing a larger proportion of this compound and consequently of  $\text{Ag}_2\text{Cl}$ , but, as already said, specimens containing more than 9 percent after thorough treatment with nitric acid to remove the uncombined subchloride I have never obtained: generally the amount is less.

"Even when silver chloride, bromide or iodide contains as little as one-half of 1 percent of sub-salt combined, its properties are greatly changed. It has a strong coloration and its behavior to light is altered. Even a much less quantity, one inappreciable to analysis, is capable of affecting both the color and the behavior to light. It is one of these latter forms of this substance that constitutes the actual material of the latent photographic image."

Carey Lea<sup>1</sup> has also shown "that silver chloride (and doubtless the other silver haloids) can unite with small quantities of certain other metallic salts. That an actual combination, though one quite outside of atomic proportions, takes place, is proved by two facts: first, that the chloride with which the silver haloid united, though soluble in water, is not removable by water; again, that the properties of the haloid are markedly changed.

"This combination with other metallic chloride furnishes a much nearer parallel case to the photo salts than does the combination with a dye. For if silver chloride is found to be capable of taking up a small quantity of ferric or other chloride, and of retaining it so firmly that it cannot be removed by washing, and only with some difficulty by  $\text{HCl}$ , we are thereby justified in admitting that the silver haloid may easily form a stable combination with a small proportion of its own sub-salt.

"In all these compounds the tendency seems always to the combination of a large proportion of the silver haloid with a small one of the other substance, whether the latter is a

---

<sup>1</sup> *Am. Jour. Sci.*, [3] 34, 384 (1887); *Jour. Phys. Chem.*, 16, 48 (1912).

dye, another chloride, or a silver sub-salt—all show the same disposition, so that I am justified in saying that my view of the nature of the photosalt is supported by the existence of many analogous bodies."

The adsorption of soluble halides has already been referred to<sup>1</sup> as accounting for the fact that Lüppo-Cramer found no soluble bromide when light had acted for a short time on silver bromide immersed in water. The same explanation undoubtedly applies to the results of Hurter and Driffeld.<sup>2</sup> "A gelatino-bromide plate (6<sup>1</sup>/<sub>2</sub> by 4<sup>3</sup>/<sub>4</sub> inches) was exposed to the light of two standard candles, one on either side of the plate at a distance of half a meter, for 33 minutes. The plate was then well washed with pure distilled water to remove any bromine which might either become free as such or which might, by action on the gelatine, have formed hydrobromic acid. The result was that no soluble bromine could be detected in the wash water."

Subsequent experiments have confirmed Carey Lea's view that the latent image is a case of what is now called adsorption. The experiments of Heyer, Baur, and Weisz, to which reference has already been made,<sup>3</sup> brought out that the last traces of the excess of silver are only acted on by very concentrated nitric acid.

#### Identity of Photohalides with Latent Image

Though Carey Lea was the first to suggest that the latent image is a case of what we now call adsorption, the working out of this idea is due chiefly to Lüppo-Cramer,<sup>4</sup> who has emphasized the fact that the photohalides of Carey Lea are identical with some of the latent images produced by long exposure to light. The recent experiments of Reinders<sup>5</sup> have helped greatly to clear up the whole question of the photo-

<sup>1</sup> Jour. Phys. Chem., 17, 100 (1913).

<sup>2</sup> Ibid., 15, 350 (1911).

<sup>3</sup> Ibid., 17, 96 (1913).

<sup>4</sup> Cf. Kolloidchemie und Photographie, 70 (1908).

<sup>5</sup> Zeit. phys. Chem., 77, 213, 336, 677 (1911); Jour. Phys. Chem., 16, 10 (1912).

halides. He fused silver and silver chloride together and also shook them together in presence of concentrated ammonia for 14 days both at 100° and at 20°. These experiments were carried on in the dark and gave negative results. He also ran a series of experiments in which silver chloride was allowed to crystallize from solution in daylight. Some of his conclusions were as follows:

(1) No stable compound of metallic silver and silver chloride is formed either at high or low temperature.

(2) When silver chloride crystallizes from solution in diffused daylight, the crystals are colored uniformly throughout. The crystals have exactly the same form as the pure silver chloride.

(3) In concentrated solutions of ammonia or of sodium hyposulphite the photochloride dissolves to a colorless solution of silver chloride, the excess of silver remaining as a black powder. In the case of some very dark blue samples this excess varies from 0.5-1.0 percent. In most crystals it was much less, barely a few tenths of a percent.

(4) If a little gelatine is added to the ammonia solution, the photochloride dissolves completely, forming a silver solution, the color of which varies with the color of the photochloride, the blue crystals giving a red solution and the red crystals a yellowish brown one.

(5) Colloidal gold and some organic dyes are taken up by silver chloride, the crystals being uniformly colored. The crystals of potassium, rubidium, and caesium alums can be stained with colloidal silver.

(6) Photochloride is silver chloride colored with adsorbed colloidal silver.

The identity of the photohalides with the latent image produced by fairly long exposures follows from a study of the behavior towards reagents. A further confirmation is to be found in Lüppo-Cramer's experiments<sup>1</sup> on the behavior of

<sup>1</sup> Lüppo-Cramer: *Phot. Correspondenz*, 46, 493 (1909); 47, 128 (1910); 48, 363 (1911); *Jour. Phys. Chem.*, 16, 97, 99, 122 (1912).

synthetically prepared photochloride gelatine and on the analogous behavior of a chloride film which has been exposed to light.

"In a previous paper<sup>1</sup> I have shown that the silver nucleus adsorbed in the photochloride acts chiefly as optical sensitizer and that clear light-images can be obtained on such films. The photochloride therefore has not the characteristics of a 'nucleus' and only acquires these when exposed to light. This discovery of mine was quite unexpected and seemed to be awkward for the theory of the latent image on silver chloride being an adsorption compound of silver. This objection was raised by Eder.<sup>2</sup> There are several things to be said in regard to this. The synthetically prepared silver chloride gelatine was treated with strong oxidizing agents to remove the soluble adsorbed silver. It is well-known that such a proceeding weakens very considerably the latent image due to light or prevents its development. If the photochloride gelatine is not treated with oxidizing agents, the films develop rapidly and intensely either with chemical or physical development.

"It seems rational to treat the photochloride formed by light in the same way as the synthetically prepared product. Fine-grained silver chloride gelatine plates were exposed to diffused daylight until they were colored pink and were then treated for 5 minutes with a chromic acid mixture,<sup>3</sup> after which they were washed thoroughly and dried. On these plates it was possible to develop strong pictures with an absolutely clear ground either by physical or chemical (ferrous citrate) development. The very fine-grained silver chloride films used at first, bleached nearly completely after treatment with chromic acid and consequently showed practically no color-sensitiveness. I therefore changed to a silver chloride emulsion having a somewhat coarser grain. Very satisfactory for this purpose was a recipe which I had found useful in

<sup>1</sup> Lüppo-Cramer: *Phot. Correspondenz*, 46, 273 (1909).

<sup>2</sup> *Phot. Correspondenz*, 46, 279 (1909).

<sup>3</sup> Five grams  $K_2Cr_2O_7$ , 15 cc concentrated  $H_2SO_4$ , 500 grams water.

making emulsified photochloride.<sup>1</sup> If one omits the colloidal silver and, of course, the treatment with persulphate, one obtains a fine, white emulsion which turns blue in the light and is not bleached by chromic acid. Such films, of photochloride prepared by light, show a panchromatism over the whole visible spectrum similar to that shown by my photochloride plates prepared by adsorption. We thus have in the photochloride films formed by light exactly the same behavior as in the synthetically prepared product. Experiments with silver bromide gelatine gave results of the same general nature.

"It is known that dry plates which have received a solarizing exposure may be made ready to receive a new impression by treating with persulphate<sup>2</sup> or hydrogen peroxide.<sup>3</sup> It is clear that this is analogous to the behavior of the photochloride gelatine when treated with oxidizing agents, quite regardless of whether the silver nucleus is the result of exposure to light or of adsorption.

"It was found [in the paper last quoted] that the photochloride obtained by adsorption is readily reduced by the developer only when, in addition to the insoluble and firmly adsorbed silver, there is also in the silver chloride grain some free silver or some silver which is less firmly held. The photochloride obtained by light behaves in exactly the same way. If the soluble silver is removed, the remaining, firmly adsorbed, silver acts merely as an optical sensitizer. In this respect there is also a complete agreement between the two photochlorides, though prepared in such different ways. The products obtained by the action of light on silver bromide we have similarly as can clearly be seen in the so-called Albert experiment.

"I have elsewhere remarked that the interesting characteristic of the synthetically prepared silver bromide, of giving

---

<sup>1</sup> Lüppo-Cramer: *Kolloidchemie und Photographie*, 99 (1908).

<sup>2</sup> Schaum: *Phot. Correspondenz*, 39, 583 (1902).

<sup>3</sup> Lüppo-Cramer: *Phot. Correspondenz*, 39, 695 (1902).

reversed pictures on development after an exposure, is apparently not in harmony with the reactions of the photochlorides or with the behavior of the photobromides when obtained by exposure to light. The analogy is, however, really complete. The photobromide gelatine emulsions, as appears from my careful description of the method of preparation, were treated with a fairly dilute nitric acid, in order to prevent any disturbing liquefying action of the acid on the gelatine of the emulsion. Under these conditions, what silver was really 'free' was removed but we did not remove all the silver that could be taken out by oxidizing agents. If the dried photobromide film is dipped again into a strongly oxidizing solution, 10 percent chromic acid for instance, there is no change in the color of the film, but such plates then give normal images when developed just as do the photochloride gelatine films. When photobromide gelatine is treated with strong oxidizing agents it behaves exactly as does silver when given a solarizing exposure and then treated with strong oxidizing agents. The agreement is so complete that I could illustrate the effect of chromic acid in eliminating reversals on my synthetically prepared photobromide plates by means of the pictures which Eder<sup>1</sup> has published in connection with his investigations on the elimination of photochemical solarization by chromic acid.

"The solarization of silver bromide is forced back by substances like hyposulphite or sulphite, which dissolve silver bromide, and the reversing action of light on the synthetically prepared photobromide is also checked by these substances. It was often observed that where the light had bleached some of the fields under a plate tester, the color became darker when the film was treated carefully with substances which dissolve silver bromide. What happens is that the lighter portion, where the silver bromide has been superficially regenerated is dissolved and the darker photobromide is exposed.

---

<sup>1</sup> Eder and Valenta: *Sitzungsber. Akad. Wiss. Wien*, 113 II, 168 (1904).



"Another important agreement between the synthetically prepared photohalides and the photo-decomposition products of the halides is the decrease in sensitiveness which comes to the silver halide from the adsorbed silver regardless whether the silver is obtained by exposure to light or by direct adsorption."

One of the objections to considering the latent image as a photohalide is that we do not get bright pink plates when we expose a dry plate to light. This objection has recently been discussed by Lüppo-Cramer<sup>1</sup> who admits that 'the question might be raised whether it would not be possible to obtain the scale of colors by exposing the silver halides to white light, varying merely the intensity or the time of exposure. Regular photographic practice shows that this is generally not the case. On printing-out paper one never observes either a yellow or an orange-colored silver nor do we get marked differences in color in the different tones of a print. With ordinary silver bromide films there is even less of any definite color to be seen. It is possible that the speed of reduction might be the reason why, with silver chloride, they form at once the largest particles of silver which are possible in view of the size of the silver chloride grains. With most silver bromide films, the absence of any vivid color as a result of the direct photochemical decomposition is due chiefly to the fact that these emulsions contain grains of very different sizes.'<sup>2</sup> Even if some of the grain tended to give bright colors, this difference in size would keep such an effect from being noticeable because very impure colors would result from the photochemical decomposition of the grains of such different sizes.

"Now I found, when studying the development by light of the latent images produced by Röntgen rays, radium rays and ultraviolet light,<sup>3</sup> that certain fine-grained silver bromide films (Schleussner transparency plates), after disintegration

<sup>1</sup> Phot. Correspondenz, 48, 353 (1911).

<sup>2</sup> Ibid., 47, 576 (1910).

<sup>3</sup> Lüppo-Cramer: Die Röntgenographie, 29 (1909).

by these forms of energy, developed a rather bright pink color when decomposed more by light. When exposed to light in presence of halogen adsorbers, these films gave sometimes quite distinct colors. Microscopical investigation showed that the grain was fairly uniform.

"I obtained extraordinary interesting preparations by bathing these plates in a 2 percent silver nitrate solution and then drying. If these plates are exposed under the Chapman Jones plate tester to sunlight for 1-2 hours, or for a correspondingly longer time (1-2 days) to bright, diffused daylight, one sees an intensely blue-black color spread uniformly over all the twenty-five spaces.<sup>1</sup> The slight tinge of blue in the photochemical blackening does not prepare one at all for the beautiful effect which appears when the plate is fixed in hyposulphite or ammonia. In the fields corresponding to the least exposure the plate is a pure yellow, which changes as one passes along the rows through orange and red to violet and blue. The colors are so pure and beautiful that I recommend this very simple experiment to all lovers of a beautiful experiment. This color scale shows in its course a complete agreement with the color scale of colloidal silver obtained by my nucleus method<sup>2</sup> or by successive intensification of amicrons. The colors show only by transmitted light. By reflected light one sees only the bright, reflecting silver. One does not get in this way the depth of color which one gets in the previously described methods of preparing colored silver, by purely chemical methods.

"This photochemical method brings out clearly what one really ought to have expected from what is already known about colored silver. When the silver formed by exposure in silver bromide is laid bare by fixing the plate, the colors appear in the usual order, which shows that, with increasing

<sup>1</sup> Just as with the silver chloride printing papers, one notices the familiar phenomenon of a solarizing reversal, which even reaches the second stage if the exposure has been very long. This anomaly disappears when the plates are fixed.

<sup>2</sup> *Phot. Correspondenz*, 47, 337, 527 (1910).

exposure to light, the particles grow from yellow to red and blue. This growth takes place fairly slowly in the case of silver bromide and possibly more uniformly and more effectively.<sup>1</sup> I have not been able to obtain similar results with any silver chloride preparation.

"The formation of the silver evidently takes place on the surface of the silver bromide grains, for oxidizing agents destroy nearly all traces of the direct photochemical blackening. In connection with this I should like to refer to a former paper,<sup>2</sup> in which I showed that yellow and reddish tones can be obtained with these silver bromide emulsions by suitable development whereby the silver apparently separates only on the surface of the grain.

"It is worth noting that no trace of color is to be seen, before fixing, on the silver bromide films containing silver nitrate. These plates therefore differ strikingly from the films of the old polychromy where the great difficulty was that the colors could not be fixed. When the bluish black silver is fixed, there is probably a peptonizing disintegration of the silver similar to that observed when Röntgen ray latent images are developed by light. A similar change in the dispersity of silver was also noticed by W. Reinders when his crystallized photochlorides dissolved in ammonia containing gelatine; the blue photochloride gave red silver and the red photochloride yellow silver."

There has been a good deal of discussion whether the constituents of the new phase are silver bromide and silver or silver bromide and an unknown subbromide. This is rather a

---

<sup>1</sup> I have assumed that here, as in many cases, the speed of the photochemical reduction has an effect on the degree of dispersity of the silver. In favor of this point of view is the fact that all changes in the sensitizing bath, which increase the rate at which halogen is removed, prevent the formation of the different colors on the silver bromide films containing silver nitrate. The addition of citric acid, the conversion of silver salt into ammoniacal silver oxide, even the increase of the silver nitrate concentration to 10 percent, prevent the formation of the color scale; only uniformly brownish or reddish colored images being formed.

<sup>2</sup> *Atelier des Photographes*, No. 8 (1908).

waste of time. In the case of solid solutions it is the fashion to give the alleged constituents; but we have no certain method of deciding what they are. If we have a continuous series of solid solutions, as with potassium sulphate and ammonium sulphate, there is no reason to postulate anything but the two single salts as the substances which crystallize together. When copper sulphate crystallizes with a large excess of ferrous sulphate, it is often said that the constituents are  $\text{FeSO}_4 \cdot 7\text{H}_2\text{O}$  and a hypothetical  $\text{CuSO}_4 \cdot 7\text{H}_2\text{O}$ ; but we do not know this definitely. When it comes to copper and zinc, which form several series of solid solutions, we are absolutely at sea. We can postulate allotropic forms of copper or of zinc, or we can invent imaginary compounds, the last being the popular practice; but we know absolutely nothing about it. In the case of the latent image, we are apparently dealing with a case of adsorption instead of solid solution; but that does not help matters very much as yet. If one insists on specifying the constituents, it is at least simpler not to assume a hypothetical subbromide. There is also the further advantage that one can connect the colors of the photohalides with the colors of colloidal silver.<sup>1</sup>

"All the properties point to the photohalides being normal salts of silver which are colored by a small amount of colloidal silver. We can picture to ourselves the way in which the particles of colloidal silver are distributed through the silver halide crystals as being similar to that postulated by Siedentopf for the distribution of metallic sodium through blue rock-salt. The different properties of the photohalides must be due to the number, the shape, and the distribution of the particles of colloidal silver through the solid silver halide. When the photohalides are exposed to light, we get the same order of colors, yellow, orange, red, violet and blue, which we get from the reduction of gold or silver solutions, the series ending with the coagulation of the metal. Consequently, it is probable that the difference in the color of the

<sup>1</sup> Reinders: *Zeit. phys. Chem.*, 77, 363 (1911); *Jour. Phys. Chem.*, 16, 104 (1912).

photohalide is due chiefly to a difference in the size of the particles of silver."

**Arguments against Decomposition Theory are not Arguments against Adsorption Theory**

Most of the arguments against the latent image being a reduction product turn out, when examined, to be arguments against the existence of silver or of a definite subhalide. They lose their force in the case of a phase of variable composition. Thus Chapman Jones<sup>1</sup> writes:

"If there is decomposition, the amount of silver salt that is decomposed must be exceedingly minute, small almost beyond imagination. The amount of decomposition might be increased many thousands of times before the products of decomposition would have accumulated in sufficient quantity for direct recognition. The exceeding minuteness of the extent of the decomposition is allowed, as it must be, by all who advocate the decomposition theory, but it is a very weak point in that theory, as will be subsequently shown. If the change is regarded as physical only, this difficulty disappears altogether, and the quantity of silver salt changed into the developable condition is readily recognized and weighable.

"The remarkable stability of the developable image has been adduced as an argument in favor of its consisting of a substance that is chemically, and not merely physically, different from the original silver bromide. But there is no reason why a physically changed silver bromide should not be as stable, or even more stable, than the subbromide. The soluble and insoluble varieties of sulphur remain soluble and insoluble respectively for long enough. The black and red sulphides of mercury are chemically identical, and both are stable. The same may be said of the yellow and red oxides of mercury. And each of these substances, it may be noted, behaves to certain reagents in a different manner

---

<sup>1</sup> "Science and Practice of Photography," 378 (1904); Jour. Phys. Chem., 15, 339 (1911).

from the other, though both, in each case, have the same composition. Many other examples might be quoted. On the other hand, many of the products of chemical change are exceedingly unstable.

"The stability of the developable image is not much argument for or against either theory of the nature of the developable image, but what little weight it has, appears rather to favor the physical theory. An exceedingly minute amount of metallic silver or silver subbromide would probably be more readily affected by outside adverse influence than a physically modified silver bromide present in relatively very large quantity. Moreover, the silver or the subbromide is in any case, according to the chemical theory, in the immediate presence of the bromine that it has lost, and one cannot accept this theory without supposing that the bromine easily leaves the gelatine and returns to the silver or else that aerial oxygen readily oxidizes the subbromide, as these are the only explanations of reversal that have been suggested to fit in with that theory. The stability of the developable image becomes, therefore, from this point of view, a strong argument in favor of the physical theory, because it is necessary that the image shall be unstable according to the chemical theory."

The stability of silver or of a hypothetical silver subbromide adsorbed by a large mass of silver bromide is quite different from the stability of the substance as a separate phase. In the experiments of Carey Lea, previously cited, it was shown that soluble salts were retained by silver chloride so that they could not be removed by washing. Animal charcoal will decompose barium formate, sodium acetate, lead acetate, calcium glycollate, zinc lactate, ammonium oxalate, and sodium potassium tartrate to some extent, so that the percolates are distinctly acid.<sup>1</sup> Sodium, calcium, and barium benzoates are adsorbed to such an extent that practically pure water passes through, and the same is true of mercuric chloride.

<sup>1</sup> Liebermann: Jour. Chem. Soc., 34, 109 (1878).

The alleged difficulty in regard to solarization no longer exists because we know now that the bromine does not return to the decomposed silver bromide. The minuteness of the decomposition is no longer a weak point because the whole grain of the silver halide is affected. This accounts for the whole grain being reduced by the developer and for the image not spreading under ordinary conditions. The difficulty in inoculating silver bromide with metallic silver is due to not getting the silver so that it can be adsorbed. Once that was appreciated, there was no further trouble.

Hurter and Driffeld<sup>1</sup> had trouble with energy calculations.

"That any ordinary camera exposure is inadequate to produce a material decomposition of the silver bromide on the plate can be shown by other experiments and considerations. A standard candle consumes 120 grains or 7.77 grams of spermaceti per hour, or about 0.0021 gram per second. The energy evolved by the combustion of 0.0021 gram spermaceti (1 gram = 10000 units of heat) is 21 gram-units (small calories). If the whole of this energy were produced in the form of chemically active light and evenly distributed over a sphere of 1 meter radius = 125,663 square cm, the amount of energy per 100 square cm of surface would be  $\frac{21 \times 100}{125,663} = 0.016$  gram-units of heat.

"While it is possible on a sensitive plate to produce a deposit of 26.5 mg of metallic silver per 100 square cm area by an exposure of 10 C. M. S., the amount of energy received by this area, assuming the whole energy yielded by the candle to be taken into consideration, as in the above calculation, is  $10 \times 0.016 = 0.16$  units in 10 seconds. Now the decomposition of silver bromide, equivalent to 108 mg of silver, requires energy amounting to 23 gram-units and the energy necessary for 26.5 mg of silver is 5.6 units, so that the candle, even if the whole of its energy of combustion were active in

<sup>1</sup> Jour. Phys. Chem., 15, 355, 362 (1911).

decomposing silver bromide, could only decompose 2.9 per cent of the amount which experiment shows can be actually amenable to development. As a matter of fact, however, only a small fraction of the energy of the candle is transformed into radiant energy; and again, a very small fraction of the radiant energy constitutes ethereal waves of sufficiently short wave length to affect silver bromide. It is thus rendered quite evident that the candle can only furnish an infinitesimal part of the energy necessary to produce 26.5 mg of metallic silver per 100 square cm with an exposure of 10 C. M. S., and that the whole of this energy is, in all probability, provided by the developer.

"Prof. Bothamley has directed most of his remarks to chemical changes, which he believes to be induced by the light, and which he supposes to be so profound as actually to reduce the silver bromide to some subbromide. Whatever may be the formula of this subbromide, it means the complete separation of some bromine from silver. Professor Bothamley does not say that the energy necessary for this reaction is supplied, even in part, by the supposed formation of a bromine compound of gelatine, but this must be the meaning of his remarks as to the facility of the formation of a bromine compound of gelatine and as to the amount of heat developed. His belief summed up appears to be that the latent image is formed by the transference (under the influence of light) of bromine from the silver bromide to the gelatine, with the consequent formation of some subbromide of silver, the possible existence of which, as a laboratory product, we do not deny. But we have always understood these subbromides to be colored bodies, and the latent image resulting from ordinary photographic exposures is not colored. Prof. Bothamley will readily admit that bromine when combining with gelatine will do so either by forming a substitution product (when hydrobromic acid will appear as well) or by forming a simple addition product. Our quantitative experiments are quite decisive as to the non-production of hydrobromic acid, and to prove that there is,



at any rate, no substitution product. They are, however, not decisive as regards the formation of an addition product; and this fact was stated in our original communication in 1890.

"But whichever product be formed, the great question still remains—whence is the energy derived which separates the bromine from the silver? The possible formation of a bromine compound of gelatine may reduce the amount of energy required to bring about this separation to about one-half of the 23 calories, since the heat involved on substituting bromine for hydrogen is, at most, 11 calories per atom of bromine taken from the silver; and 14 calories if an addition product be formed. The greatest difficulty with regard to the subbromide theory, therefore, still remains, namely, the energy difficulty; and it remains even if the combination of bromine with gelatine were a proved fact, which, as far as we are aware, it is not; or is simply an opinion."

These difficulties are very real if we assume reduction to silver subbromide and still more serious if the silver bromide is reduced to free metallic silver. They vanish entirely on the basis of the adsorption theory because the difference in the energy content of the undecomposed and the decomposed silver bromide can theoretically be made as small as one pleases. Practically, the difference which can be detected depends upon the sensitiveness of the developer. I do not believe for a moment that a very faint light produces no change in silver bromide. What happens is that the change produced is too small to be detected by any developer as now used.

#### **Reactions of Latent Image**

Since the latent image consists of silver bromide with varying amounts of adsorbed silver, it will not show the reactions of either silver bromide or silver in their entirety. The latent image will be more resistant than either silver bromide or silver to substances which attack the one or the other. Since the latent image on any plate varies with the degree of exposure we shall expect to find that the reactions

vary to some extent with the degree of exposure. Both of these generalizations are true.

As has already been pointed out,<sup>1</sup> the latent image is destroyed by nitric acid, the attack being more rapid the more concentrated the acid. It is also destroyed by chlorine, bromine, or iodine; by ferric chloride, mercuric chloride, or gold trichloride; by chromic acid, potassium persulphate, acidified potassium permanganate, or potassium ferricyanide; by hydrobromic acid, hydrochloric acid, or potassium iodide. In other words, these substances attack the material composing the latent image more readily than they do the unexposed silver bromide. With the exception of potassium iodide, all these substances attack silver much more readily than they do silver bromide, while the rate of destruction of the latent image is much lower than would be the case were we dealing with free metallic silver.

The case of potassium iodide is a bit doubtful. It is usually stated that potassium iodide destroys the latent image. Messrs. Hurter and Driffeld<sup>2</sup> say that "when silver bromide is treated with a solution of potassium iodide, chemical decomposition takes place, the bromine and iodine are exchanged, and we then have silver iodide. This reaction takes place also in the case of silver bromide in the sensitive film. If silver bromide which has been exposed to light (*i. e.*, impressed with a latent image) consisted of subbromide, this subbromide would either remain as such, when treated with potassium iodide, or it would yield a subiodide. In either case it ought to yield, upon development, a visible image; but the treatment of a latent image with potassium iodide completely destroys the latent image. . . . ."

This statement has been disputed by Bothamley<sup>3</sup> who says he "once treated two or three exposed gelatino-bromide plates with a 5 percent solution of potassium iodide for a considerable time, washed out the potassium iodide, and treated the plates

<sup>1</sup> Jour. Phys. Chem., 15, 313 (1911).

<sup>2</sup> Ibid., 15, 354 (1911).

<sup>3</sup> Ibid., 15, 361 (1911).

with the developer; casual observation would have led one to suppose that the developable image had been destroyed, but some later work, however, threw doubts on that conclusion. It seems possible that the latent image was there but that the time for its development was very long, and I found that by allowing the ferrous oxalate developer to act for a good many hours I was able to develop an image. Recently, Schumann has made an experiment in which he had found that the ordinary belief that an emulsion of silver iodide in gelatine will not give a latent, or developable image is contrary to actual fact, and that if such an emulsion is subjected to light of very high refrangibility, you can get an image and develop it just as in the case of silver bromide."

If we consider substances which attack silver bromide more readily than they do metallic silver we find as was to be expected that they react with the silver bromide before reacting with the latent image though they can be made to attack the latter. Thus sodium thiosulphate dissolves unexposed silver bromide more rapidly than it does silver bromide which has been exposed to light. The same general statement is true, though to a varying degree, in regard to ammonia, to potassium cyanide, and to ammonium bromide.

Some of the peculiar characteristics of the latent image are brought out clearly in a paper by Lüppo-Cramer.<sup>1</sup>

"The latent image on fine-grained and on ordinary dry plates is completely destroyed and physical development is prevented if the plates are first fixed in a hyposulphite solution and are then bathed for a few minutes in solutions which dissolve both silver and silver bromide. For this purpose we may use a mixture of sulphocyanates with strong acids or a mixture of sulphocyanate or hyposulphite with bisulphite. A solution of 10 grams hyposulphite and 20 grams potassium pyrosulphite ( $K_2SO_5SO_2$ ) in one hundred parts of water destroyed the previously fixed latent image completely in 10-15 minutes even when the exposures had

---

<sup>1</sup> Phot. Correspondenz, 43, 388 (1906); Jour. Phys. Chem., 16, 51 (1912).

been so long that the check plates were much over-developed.<sup>1</sup> If a little more time is given, slightly acid fixing baths destroy the latent image. In fact, four years ago<sup>2</sup> I published the fact that the latent image in a collodion emulsion is distinctly weakened by a preliminary fixing, in case the fixing bath contains bisulphite.

"We thus find completely analogous reactions for the negative image after the silver has been removed, for the visible image, and for the latent image. Since those substances, which we have hitherto considered as subhalides of varying compositions, are readily destroyed by any solvent which attacks silver and silver bromide, it seems to me that we must be dealing with a solid solution of silver in silver bromide, since it is not decomposed either by reagents which only dissolve silver, or by reagents which only dissolve silver bromide. It is only on the assumption of a solid solution or of a compound like the lakes, that it is easily intelligible how the products, resulting from the action of light on the silver halides, can show such remarkably complicated reactions with solvents of silver bromide on the one hand, and with solvents of silver on the other hand, as have been described by Eder recently in his magnificent paper<sup>3</sup> on 'The Nature of the Latent Image.'"

The different reactions of the latent images due to different exposures are brought out clearly in the paper by Eder<sup>4</sup> to which Lüppo-Cramer referred in the last paragraph. Eder says that the subhalide theory is able to explain without difficulty the complicated experimental behavior, toward chemical reagents, of the latent image in a silver bromide film; but he does it by introducing various undefined modifications of silver subbromide. There is nothing to be gained, from a scientific point of view, in postulating the coexistence

---

<sup>1</sup> Bisulphite retards very much the fixing in hyposulphite; neutral sulphite acts the same way.

<sup>2</sup> Phot. Correspondenz, 38, 359 (1906).

<sup>3</sup> Sitzungsber. Akad. Wiss. Wien, 114 IIa, 1159 (1905).

<sup>4</sup> Cf. Jour. Phys. Chem., 13, 57 (1909).

of numberless unknown silver subbromides. If Eder had expressed it in terms of silver bromide with continuously varying amounts of adsorbed silver, he would have accounted for the phenomena and he would also have raised the question as to what compositions corresponded to any given set of properties. With this word of warning, I quote Eder's explanation in full<sup>1</sup> as illustrating admirably the point that the reactions of the latent image vary with the composition thereof.

*"The substance of the normal latent image (negative of the first order) consists of silver bromide reduced in varying amounts to subbromide.*

*"We assume further for the case of progressive illumination that, in consequence of a photochemical setting free of bromine, at the beginning of the exposure to light there is formed a silver bromide corresponding very closely in composition to normal silver bromide. This subbromide, however, as we see from the process for making photographic negatives is more rapidly reduced by reducing agents to metallic silver than is the pure unexposed silver bromide. This modification of subbromide is destroyed by thiosulphate as well as by nitric acid. By means of this assumption we explain all the phenomena recorded in regard to the latent silver bromide images which result from very short exposures.*

*"With a somewhat longer exposure there is formed a silver subbromide which constitutes the latent image of the normal negative. It is only slightly attacked by nitric acid. With increasing exposure it yields on development a normal negative with the normal characteristic blackening curves corresponding to it. This silver subbromide is less readily soluble than silver bromide in solutions of the fixing media, such as ammonia, ammonium bromide, or thiosulphate. After the preliminary fixing of the latent image this subbromide therefore remains as a residual image which can be developed physically in spite of its having undergone certain*

---

<sup>1</sup> Cf. Jour. Phys. Chem., 13, 68 (1909).

changes. Depending on the chemical nature, the concentration or the temperature of the fixing bath, this silver subbromide is developed more or less completely into the soluble silver bromide and undissolved metallic silver so that the residual image consists of subbromide mixed with more or less of metallic silver. Potassium cyanide causes the greatest decomposition and with it the residue consists of metallic silver only.

"If one allows nitric acid to act on the latent image after it has been fixed, the substance forming the image is destroyed still more, the destruction being greater the more completely the image consists of metallic silver. Since the silver is dissolved, more or less of the image will be removed and there will remain behind some subbromide, the presence of which can be shown by physical development. But even this is broken down, by a continuous treatment with concentrated nitric acid, into silver which dissolves and silver bromide which does not respond in the dark to physical development, but which at once forms new nuclei for physical development if it is exposed to light and thus converted again into a developable subbromide.

"With a very strong over-exposure of the silver bromide there is formed a *solarization image*, the substance of which is not identical with the directly blackened silver bromide which is apt to be formed at the same time. This substance has a different chemical composition and different chemical properties from the substance forming the negative image of the first order.

"With more intense over-exposure and subsequent development we get the negative of the second order. The latent image from which this was formed probably consisted of a mixture of at least three chemically different substances, namely, of metallic silver, of the substance constituting the solarization image, and of the subbromide constituting the image which yields the negative of the first order. All these substances are shown to be present not only by their photographic behavior towards the photographic developer, but

by their different chemical behavior towards thiosulphate, ammonia, nitric acid, etc. The substance formed by the direct blackening of silver bromide in light shows a different photographic action from that of the latent or the solarized image. This can be explained less well on the assumption of a solid solution of variable amounts of  $\text{Ag}_2\text{Br}$  in silver bromide. It is more probable that different modifications of silver subbromide occur in the differently illuminated portions of the silver bromide film.

"The latent image on silver iodide with an excess of silver nitrate seems also to consist of silver subiodide, which, however, seems to be more easily decomposed into metallic silver and silver halide than is the case with silver subbromide.

"The substance forming the normal latent image on silver bromide does not vary in its qualitative behavior towards chemical reagents with the wave lengths of the light that produces it. Color sensitizers (eosine, ethyl violet, etc.) which make silver bromide light-sensitive to light of longer wave-length, force the silver bromide to the same photochemical reaction of the silver subbromide formation in the production of the latent image which is characteristic of silver bromide by itself in the blue, violet, and ultraviolet regions of the spectrum."

Another form of the difference in reaction with increasing exposure is the difference in reaction with difference in size of grain. A given amount of decomposition per grain produces a larger concentration in a small grain than in a large grain. With a large grain, there are also more possibilities of differences in concentration between the outside and the inside of the grain. These points have already been discussed by Lüppo-Cramer.<sup>1</sup>

"The remarkable influence of the size of the grain on the photochemical decomposition of the silver halides becomes quite intelligible if we assume the existence of solid solu-

<sup>1</sup> Jour. Phys. Chem., 16, 54, 61 (1912).

tions of silver in silver halide. The existence of a definite subhalide, Ag<sub>2</sub>Br, etc., has always been doubted and it is a substance to which one can attribute any property that one happens to need for an explanation. Even if such a compound were formed on exposure to light, that does not explain why fine-grained silver bromide should act fundamentally differently in regard to oxidizing agents. Quite accidentally, most photochemists have worked chiefly with silver bromide having a fairly coarse grain such as is obtained by precipitation from concentrated aqueous solutions, the silver bromide of the collodion emulsion, or that of the ordinary highly-sensitive dry plates. Except for this, it is probable that no one would have considered the visible blackening of silver bromide as due to a subbromide. In very fine-grained films the photochemical decomposition product behaves just like metallic silver.

"It is very improbable that a photochemical reaction, such as the reduction of the silver bromide, should vary with the size of the grain, giving metallic silver with a fine-grained emulsion and stopping at the subhalide with the coarse-grained emulsion. It is easy to see that the behavior of the photochemical decomposition product of silver bromide may vary with the size of the grain if one assumes that silver is formed in both cases but that it behaves differently when dissolved in the relatively large mass of silver bromide constituting the coarse grain than when dissolved in a small grain. One may assume that an almost complete decomposition takes place inside the very fine grains, since the blackening disappears so readily in nitric acid or chromic acid. When treated with these reagents after a long exposure to light, there only remains the infinitesimal trace of silver in solid solution which can be detected by physical development and which doubtless constituted the innermost part of the original silver bromide grain.

"With the increasing size of grain we get different phenomena as a result of photochemical decomposition. The silver is distributed through a much larger mass of solid

E

S

V

r

u

c

i

n

r

'

|

R

L

n

S

r

e

n

h

r



solvent, the dissociation pressure of bromine is different, the silver dissolved in this large complex is very resistant to oxidizing agents, though this disappears when the silver is set free from its solvent, silver bromide, by a reagent which dissolves this latter substance. Such solvents as hyposulphite or sulphocyanate cannot be used by themselves, before the treatment with an oxidizing agent. The two must be applied simultaneously because otherwise the silver dissolved in the solid silver bromide keeps this latter from dissolving. It is only when the grain is extraordinarily fine that it is possible to destroy what is left of the latent image after a preliminary fixing, by means of chromic acid or nitric acid alone. If the preliminary fixing is omitted, the latent image withstands treatment with chromic acid even in the case of the so-called grainless silver bromide emulsion.

"When the colloidal particles of a mixture of the hydrosols of silver bromide and silver begin to coagulate under the influence of electrolytes, there is formed an extraordinarily fine-grained, but distinctly reddish photobromide which is converted by concentrated nitric acid into silver bromide. A similar phenomenon occurs with silver chloride but the decolorizing by nitric acid ceases at a much lower limiting size of particles than is the case with silver bromide. When in a very fine-grained state, the photohalides do not resist oxidizing agents; they are able to do so only when they change from sols to gels.

"This is in complete accord with my experiments<sup>1</sup> on silver bromide and silver chloride emulsions. I found that the photochemical darkening disappeared completely and instantaneously when emulsions of colloidal silver halide were treated with oxidizing agents while, with coarse-grained emulsions, there was no change of color even when boiling concentrated nitric acid was allowed to act for quite a while. From this I concluded that silver was formed by the action of light in both cases; but that the behavior of silver varied

---

<sup>1</sup> Lüppe-Cramer: *Phot. Correspondenz*, 43, 28 (1906).

with the size of grain of the halide. With increasing size of grain the silver was dissolved in a larger amount of solid solvent and was therefore less readily attacked by chemical reagents. Of fundamental importance for the theory of the photohalides is the following experiment suggested by the behavior of mixtures of the hydrosols of silver and silver halide when coagulated by electrolytes.

"Plates with colloidal silver bromide gelatine were exposed under a 5 percent nitrite solution until quite dark. The color was bleached at once by 2 percent solutions of chromic acid, nitric acid, etc. If the colored films are removed from the glass and are heated with dilute sulphuric acid until the photobromide coagulates, even boiling concentrated nitric acid has no effect. I obtained similar results by treating pure silver bromide sols in a like way but the color was not so marked because the light does not have access to the silver salt so well as in the gelatine film.

"It is therefore not necessary that the silver reduced by the light should be inside a large molecular complex during the exposure in order to become chemically resistant. The coagulation by the colloidal particles to a gel after the exposure will have the same effect. It is quite clear that the purely chemical nature of the reduction product cannot be changed by the coagulation of the exposed silver bromide. Since the behavior of the exposed silver bromide is the same as that of the photobromide obtained, without the action of light from  $\text{AgBr} + \text{Ag}$ , both before and after the coagulation by electrolytes, this proves that the product obtained by exposure to light can only be silver, which loses its characteristic instability towards nitric acid by forming a compound with the normal halide. This is also the assumption made by Carey Lea in regard to his subhalide."

#### **Retrogression of Latent Image**

Photoretrogression is due to the latent image reacting with the halogen. The real problem is where the halogen comes from. It does not seem probable to me that any very

appreciable portion comes from the decomposition of a gelatino-bromide compound. It seems more likely that a certain amount of the bromine set free by light remains adsorbed temporarily in or on the silver bromide grain or on the silver bromide which was not exposed to light. Ordinarily it passes off into the air or reacts with gelatine; but it may react with the latent image if the conditions are favorable.

At first sight it seems improbable that bromine could be adsorbed by the decomposed silver bromide without reacting with it, but it is not impossible. The experiments of Carey Lea<sup>1</sup> are very instructive in regard to this.

"When silver iodide is boiled with a solution of sodium hypophosphite, it gives a brown product, evidently indicating that reduction to some extent has taken place; the hyposulphite solution may or may not show traces of iodine. The color of the silver iodide may show a very marked darkening, and yet the solution may give no trace of iodine by the most delicate reagents.

"This was very difficult to explain until I found that silver iodide has the property of taking up and retaining small portions of iodine, a reaction not very surprising in view of the tendency I have found in silver haloids to take up foreign substances of very various natures, and also of the facility with which iodine is taken up by alkaline iodides. This property in silver iodide was verified by shaking up portions of freshly precipitated and still moist AgI with iodine solutions. Alcoholic solution of iodine diluted until it has a pale sherry wine color is quickly decolorized by AgI, and the same thing happens with a very dilute solution of iodine in KI, which in a few minutes becomes as colorless as water.

"This reaction I found particularly interesting, for it not only explained the action of hypophosphite in the case just mentioned, but also gave a clue to the cause of a phenomenon I observed more than twenty years ago, and which then and long afterwards seemed to me an unanswer-

<sup>1</sup> Jour. Phys. Chem., 16, 42 (1912).

able argument in favor of the physical nature of the latent image.

"At the time referred to I formed films of pure silver iodide isolated from foreign matter, by reducing metallic silver on plates of ground glass, iodizing them with alcoholic solution of iodine, or with Levot's solution, then washing most thoroughly under a tap for hours. When these films of silver iodide were exposed to light, they received an invisible image which could be developed. But these invisible images, if the plates were laid aside in the dark, had the property of fading out in a few days or weeks, then could no longer be developed, but the film could receive a fresh image. This seemed an unanswerable proof of the physical nature of the latent image at least on silver iodide. The argument was: If the production of this latent image is the result of chemical action involving the loss of iodine by the silver salt, how then is this iodine recovered when the image fades out? If it is formed of subiodide, where does this latter substance get back its iodine to return to the normal form, as it unquestionably does?

"No answer could be given then or after, and this experiment, repeated and confirmed by others, has always seemed the strongest support of the physical theory. When, however, it appears that silver iodide can take up iodine and hold it, the course matters follow becomes evident. By the action of light a very small quantity of subiodide is formed, and combines with the normal salt to form photoiodide. The iodine set free evidently does not pass off but remains combined with neighboring molecules of  $\text{AgI}$ , and in the dark gradually recombines with the photoiodide reconverting it to normal  $\text{AgI}$ . In this retention the lower tension of iodine, as compared with bromine and chlorine no doubt, plays its part.

"In thus explaining away the fading out of the latent image on silver iodide, the last argument in favor of the physical theory is destroyed, while the chain of proof supporting this new explanation, that the latent image consists

of normal haloid combined with its own sub-salt, remains unbroken."

These experiments do not show whether the iodine is adsorbed by the decomposed or the undecomposed silver iodide. We know, however, that free chloral and free water coexist dissolved in fused chloral hydrate. We also know that acetic anhydride and water take hours to react completely when dissolved in acetic acid.

Lüppo-Cramer's experiments on photoregression are consistent with the view that we are dealing with a retention of the halogen by adsorption, since the amount of adsorption would presumably be greater with a fine-grained plate than with a plate having a coarser grain.<sup>1</sup>

"I have shown previously that the decay of the photochemical action is especially marked with iodides of mercury, that this reaction velocity is increased enormously by moisture, and that the recombination of the dissociated halogen with the mercury, taking place under the influence of water, is more complete the finer the grain of the emulsion. The decrease of the blackening with dry mercurous iodide gelatine takes place very much more rapidly and more completely with a fine-grained iodide than with the ripened emulsion. If one exposes one plate of each type until they are blackened to about the same degree and then puts them away in the dark, it is easy to notice a great difference at the end of a day or two. At the end of 2 days the fine-grained mercurous iodide has become very light while the coarser emulsion shows only a slight decrease in color. At the end of 7 days the fine-grained emulsion has entirely recovered its original bright color while the coarser mercurous iodide is still very dark.

"Stimulated by this experiment I decided to see whether a fine-grained silver bromide emulsion might not show the phenomenon of the decay of the latent image even though

---

<sup>1</sup> Lüppo-Cramer: *Phot. Correspondenz*, 44, 130 (1907); *Jour. Phys. Chem.*, 15, 324 (1911).

the highly sensitive bromide does not show it to any appreciable extent. As a matter of fact, water causes a distinct decrease in the darkening of a fine-grained silver bromide emulsion caused by exposure to direct sunlight. Nothing of the sort can be detected with highly sensitive plates. It is a question whether the decrease of the blackening with fine-grained plates is really due to a recombination of the halogen with the silver similar to that with the iodides. There is no doubt but that the latent image fades appreciably in these fine-grained emulsions, though slowly, as is the case with all latent images.<sup>1</sup> A large number of plates of the same fine-grained emulsion as that used in a previous investigation were exposed under a negative to daylight for the same length of time. Immediately after exposure half of each plate was developed, using in every case the same developer at the same temperature and developing for the same length of time. The developed halves were then put away together with the undeveloped halves. At the end of two months a marked decay of the latent image could be detected; at the end of six months only the high lights were left. There was no marked difference to be detected between plates developed after nine months and plates developed at the end of six months. There is therefore a distinct decay of the latent image on silver bromide gelatine plates when the emulsion is a fine-grained one."

The experiments of Baekeland<sup>2</sup> fit in well with this way of looking at things. With an under-exposed film, it takes less actual recombination with bromine to destroy the image than with a fully exposed one, and consequently one would expect the phenomenon of retrogression to be more marked under these circumstances, which is exactly what Baekeland found. It is quite evident that heat and moisture would accelerate the reverse reaction and would therefore increase the retrogression. In an alkaline solution the adsorbed

<sup>1</sup> Cf. Lüppo-Cramer: *Phot. Correspondenz*, 43, 80 (1906).

<sup>2</sup> *Internat. Kongress angew. Chemie, Berlin*, 4, 403 (1903); *Jour. Phys. Chem.*, 15, 314 (1911).

bromine would be decomposed much more readily than in an acid one and also the oxidizing power of the bromine would be greater in an acid solution than in a neutral. Consequently, the fading of the latent image should be more rapid in a slightly acid film than in a neutral or alkaline one, which is also what Baekeland found. Potassium iodide, bromide, and chloride would probably all act as carriers of halogen and would therefore cause a fading of the latent image.<sup>1</sup> Tannin would react with the bromine and would therefore prevent the disappearance of the latent image. Brush<sup>2</sup> found that "photographic action is slow in starting, involving considerable light energy which leaves no permanent record. If exposure is stopped at this stage, the starting action relapses almost wholly within a few minutes and is lost to further exposure." What this amounts to is that photo-retrogression is very much more marked the shorter the exposure. It is this fact of the adsorbed halogen reacting again with the latent image which makes the resultant of an intermittent lighting not equal to the sum of the single exposures.

#### Reversal, so-called, of the Latent Image

In a special series of papers,<sup>3</sup> I have shown that all the phenomena of solarization can be accounted for on the assumption that certain compositions of the latent image are less rapidly reduced than others which contain either more or less silver. This is a perfectly familiar phenomenon where we have a series of compounds as in the reduction of nitrobenzene. Nitrosobenzene is more readily reduced to aniline than is nitrobenzene though the latter contains more oxygen, while hydrazobenzene is less readily reduced than phenylhydroxylamine though the latter contains more oxygen. There is one point, however, which requires a correction.

<sup>1</sup> Barker: *Jour. Phys. Chem.*, 15, 323 (1911).

<sup>2</sup> *Phys. Rev.*, 31, 241 (1901).

<sup>3</sup> Bancroft: *Jour. Phys. Chem.*, 13, 1, 18, 269, 449, 538 (1909); 14, 292 (1910).

Partly for the sake of simplicity and partly because I knew no better, I followed Eder and assumed<sup>1</sup> that the second negative was metallic silver before development. I am satisfied now that that was an error and that the visible image on an undeveloped bromide plate consists of blackened grains which are capable of development. The only difference that this makes is that it now becomes possible theoretically to have any number of reversals, while a second positive was theoretically impossible under the original assumption.

In all discussions of solarization up to now, people have made qualitative statements. Now that we know what the latent image is, it ought to be possible to determine approximately at what composition we get a positive with any given developer. I had thought of getting at this by melting an emulsion, exposing it to light, and afterwards analyzing for bromide. This would have presented some experimental difficulties and I was glad to find that it was possible to make a first approximation by using the data of others.

Carey Lea's photobromide evidently was very close to the concentration required for reversal,<sup>2</sup> while the photoiodide was not.<sup>3</sup> "If we take the red or purple silver bromide, preparing it with exclusion of light and the same precaution as in the case of any plate, and extend it over paper (it is best, though not essential, to mix it with a little gelatine to enable it to retain its hold on the paper in the subsequent treatment), dry it and expose it to the light under a screen such as a piece of opaque stiff pasteboard with openings cut in, then apply potassio-ferrous oxalate, we shall obtain a very remarkable effect. All the parts exposed to light take a reverse development and appear as lighter spaces on a darker ground. And this goes so far that we may expose till we get the visible and quite strong image darker than the ground and yet in development this darker portion will come out lighter

<sup>1</sup> Jour. Phys. Chem., 13, 46 (1909).

<sup>2</sup> Carey Lea: Am. Jour. Sci., [3] 33, 487 (1887); Jour. Phys. Chem., 16, 109 (1912).

<sup>3</sup> Jour. Phys. Chem., 16, 115 (1902).



than the ground. Indeed I have one specimen which shows almost white figures on an intensely black ground. Before development these light figures were brown, by exposure to light, on a rose-purple ground. I have seen few more curious results than this.

"From the foregoing it follows that red bromide, notwithstanding its intense coloration, is in the same condition respecting light as normal silver bromide that has received an impression of light so strong that any further influence of light would cause reverse action, only that a vastly larger proportion of its molecules are affected. In the case of the latent image formed by light on normal bromide it would seem that the particles affected, although numerous enough to serve as a basis of development, are still too few and too scattered to be visible or affect the color. The photobromide on the contrary has its mass made up of them. Then, if exposed to light, the light carries them a stage farther—brings them to the reverse or solarized condition and the parts affected by light develop less strongly than those not exposed."

Lüppo-Cramer comments<sup>1</sup> on this as follows:

"In one of my previous papers<sup>2</sup> I have given a reproduction of a picture on a photobromide gelatine plate from which one can see that the extraordinarily surprising result described by Lea can easily be reproduced. I have also pointed out that we are not dealing with a reversal due to over-exposure but that any exposure, which has any effect at all, decreases the rate of development of the photobromide. My experiments on the gelatine emulsion of the photobromides yielded a number of results which were interesting in themselves. I prepared a large supply of photobromide plates in the following way:

"Since my experiments have shown that the photo-halides are the halides colored with colloidal silver, they can

---

<sup>1</sup> Phot. Correspondenz, 46, 397, 415, 424 (1909).

<sup>2</sup> Ibid., 46, 275 (1909).

be prepared easily by coloring the halides. It is not necessary to prepare the silver solution separately because one can precipitate silver bromide with an excess of silver nitrate and can then add a mild reducing agent such as ferrous citrate<sup>1</sup> which will reduce the soluble silver salt to colloidal silver but which will not reduce the silver bromide. After the reduction product has been washed for a while, it is treated with nitric acid to remove the uncombined silver. In this way there is obtained a beautifully violet-colored photobromide which can readily be peptonized by bromide ions in gelatine to a homogeneous, fine-grained, pink emulsion. After the bromide salts have been washed out, the emulsion can be worked up in the usual way.

“These red photobromide plates behave in a very remarkable way when exposed to daylight. They do not become darker, as was the case with Carey Lea’s paper; but they *bleach* to a *light grayish white* after an exposure of several minutes to diffused light. If the film is exposed to daylight for about half an hour under the Chapman Jones plate tester, one notices, even with yellow light, a surprising effect which I confess is *one of the most remarkable in my experience*. The whole scale comes out a light gray to white on the red ground and it looks as though the photobromide had been changed back into silver bromide. If the plate is placed in the ordinary metol developer, there appears, in a short time, a clear but reversed image on a black ground; it is interesting to note that, with a longer exposure of about an hour and a half, the first fields show distinctly the beginning of the second reversal of the solarization, the first numbers of the scale developing dark instead of light. An ordinary silver bromide plate (Schleussner yellow label) does not show any signs of a second reversal when exposed for 6 hours. As analogy to the second reversal of the solarization, a prolonged exposure of the photobromide film causes a bleaching and then a darkening. In this later stage a distinct residue is left if

<sup>1</sup> Cf. Lüppo-Cramer: Zeit. Kolloidchemie, 2, 360 (1908).

the plate is fixed. This new darkening of the bleached photobromide has no definite color and is a neutral gray. If the photobromide gelatine is dipped in a 1 percent silver nitrate solution and then exposed under the plate tester, the result is quite different. The light does not bleach the plate but makes it darker. On development we get a normal image though one that is badly fogged regardless of whether we develop physically or chemically. This experiment is in line with the fact that halogen absorbers prevent the occurrence of solarization<sup>1</sup> with ordinary silver bromide gelatine. Moistening the photobromide film with sodium nitrite also causes a rapid and intense darkening in the light.

"These reactions made it seem possible that the small amount of colloidal silver might have been converted into silver bromide, on exposure to light, by the traces of bromide from the peptonization, since perhaps they could not be washed out of the photobromide. Therefore the excess of silver was removed from the photobromide with nitric acid and the photobromide was merely washed and then taken up in gelatine without any addition of bromide. If one makes use of the artifice which I employed with pure silver bromide only to take a little gelatine at first, the photobromide can be got into a fine suspension very satisfactorily, though by no means so well as with the aid of bromide. These films also bleached in the light though there was a preliminary darkening in some of my many experiments. But even these plates behaved like Carey Lea's paper and always yielded reversed images on development. From these experiments we see that it is not permissible to assume that the bleaching of the photobromide is due to the action of traces of bromide left in the film. The residue left after fixing plates, which have been exposed till they bleached or until they darkened again, indicate that, taking the films as a whole, there are more silver nuclei formed the longer the exposure."

More accurate data have been obtained since then by

---

<sup>1</sup> Lippo-Cramer: *Photographische Probleme*, 139 (1907).

Lüppo-Cramer,<sup>1</sup> who prepared silver bromide emulsions containing known amounts of colloidal silver taken up by the silver bromide. When the silver bromide contained 0.002 percent silver synthetically, there was a distinct fogging on development. With increasing amounts of silver the rate of blackening in the developer increased and the sensitiveness to light increased until a maximum was reached at about 0.1 percent silver. An emulsion containing 0.1 percent silver is about twenty-five times as sensitive as one containing 0.4 percent silver. This gives the necessary figures for this type of emulsion and for the developer used. From 0.002-0.1 percent silver we are dealing with the first negative. Somewhere just beyond 0.1 percent silver we pass to the first positive. It is interesting to note that this is about the value given for the maximum decomposition when one is to develop a negative.

Since we get a solarized image when the concentration of adsorbed silver becomes too high, it is clear that any reagent which will remove enough of the adsorbed silver will cause the plate to develop as a negative. On the other hand, all exposures give negatives if the silver bromide is dissolved and the plate is then developed physically.

#### **Latent Image due to Pressure, Heat, Acids, Etc.**

Carey Lea<sup>2</sup> has shown that a developable latent image can be produced by the action of acids, pressure or heat.

"Dilute sulphuric acid quickly changes allotropic silver to normal, and therefore if the parallelism which I have indicated really exists, marks made on bromide paper with dilute sulphuric acid should be capable of development.

"The experiment was made by drawing characters on silver bromide with a glass rod dipped into sulphuric acid diluted with twice its bulk of water. After allowing the acid to remain in contact for 2 or 3 minutes, the paper was im-

<sup>1</sup> Phot. Correspondenz, 46, 526 (1909); Jour. Phys. Chem., 16, 119 (1912).

<sup>2</sup> Am. Jour. Sci., [3] 41, 262 (1891); 43, 528 (1892); Jour. Phys. Chem., 15, 330, 327 (1911).

mersed in running water and washed for an hour or two. On applying the oxalate developer nothing appeared. Feeling confident that an effect must be produced, the experiment was repeated several times and the results closely examined. On one specimen it was found that the characters had appeared, but reversed, that is, lighter than the ground which had darkened by the development being pushed. This at once gave a clue; it showed that the traces of the acid adhered too strongly to be removed by washing and, by locally checking the development, interfered with the reaction. Accordingly, next time after a very short washing, the paper was immersed in water to which a trace of ammonia had been added, and after 10 or 15 minutes' action, the ammonia was thoroughly washed out. The result was striking: as soon as the developer was applied, the characters which had been traced with acid came out strongly as brown marks on a white surface.

"Cold sulphuric acid even undiluted is generally held to have no action on silver haloids, but it is well known that the hot, strong acid decomposes them. The foregoing experiments leave no doubt that the cold dilute acid produces an initial effect invisible to the eye but revealed by greater tendency to give way under the action of a reducing agent. This action of the acid comes, therefore, exactly into line with that of light and heat. In all three cases an effect is produced inappreciably until a reducing agent is applied. But in all three cases the agent which produced this invisible effect is capable by continued action under favorable conditions of bringing about a visible change without the aid of a reducing agent.

"I was able to show many years ago that mechanical force could produce a latent image. Lines drawn with a glass rod on a sensitive surface could be rendered visible by development in the same way as impressions of light. An embossed card pressed on a sensitive film left an invisible image which could be brought out by a reducing agent. The raised portions of the embossed work exert a stronger pres-

sure on the sensitive film than the rest of the card and these portions darkened when acted upon by a reducing agent. In the same way, the lines traced with a glass rod, blackened under a developer. In each case, it was the portions which had been subjected to pressure which yielded first to the reducer. It is therefore clear that in the molecules which had received this slight pressure the affinities of the atoms had been loosened."

I doubt whether these images are the same as the ordinary latent image. We know that precipitated silver bromide, containing no gelatine, is reduced almost as rapidly before exposure to light as after exposure. We know that in an emulsion the silver bromide grain contains gelatine and water. Anything that will remove the gelatine will cause the silver bromide thus treated to develop more rapidly than the remaining silver bromide. I think that this is what happens in the cases under consideration and I think that we do not have a true latent image in the sense of a partially reduced silver bromide. This view is confirmed by some results of Lüppo-Cramer.<sup>1</sup>

"The experiments on the action of nitric acid on silver bromide gelatine and on the latent image were undertaken to find out whether there was any metallic silver in the latent image. The experiments proved nothing in regard to this, because the gelatine was destroyed by the action of the concentrated acid necessary to dissolve the silver. Curiously enough other investigators do not seem to have noticed a secondary phenomenon which attracted my attention when I repeated the experiments.

"An exposed silver bromide gelatine plate, on which I had as usual left a broad unexposed strip, was placed for half a minute in a dilute nitric acid (8.3 percent). The gelatine was attacked but remained on the plate. The plate was washed thoroughly and was developed along with another from the same emulsion, which had received the same exposure but which had not been dipped in nitric acid. I ob-

<sup>1</sup> Jour. Phys. Chem., 15, 574 (1911).

tained the entirely unexpected result that the plate which had been dipped in acid blackened even on the portions which had not been exposed, while the unexposed strip of the check plate remained quite clear. The same result was obtained even when the solution contained only one-half to one-fourth percent nitric acid and though no change in the gelatine was then visible. The effect disappeared when an extremely dilute nitric acid (0.05 percent) was used. A fogging of the unexposed silver bromide was also obtained by means of sulphuric acid but the sulphuric acid does not produce as marked changes in the gelatine as the nitric acid nor does it fog the plate so much. A 10 percent sulphuric acid is approximately equivalent to a 0.5 percent nitric acid. A 5 percent ammonium persulphate solution is about equivalent to these acids.

“That three substances which act so differently chemically should all act in the same way on silver bromide seems less intelligible than that the action should be upon the gelatine, though even this furnishes us with an interesting and difficult problem. We really know as little about development as about the latent image. Even when the gelatine, which forms a sheath, so to speak, round the silver bromide, is only slightly attacked, the bromide is nevertheless changed as though it had been exposed to light. This is even more remarkable than the fact to which I recently called attention, that substances which are not developers, such as gallic acid and formaldehyde, are readily able to reduce silver bromide which has been precipitated with no protecting colloid present, quite regardless of whether there has been an exposure to light or not. We find it impossible to conceive that persulphate or a dilute acid should produce a chemical change in silver bromide; we have no reason to suppose that the silver bromide undergoes any physical change during the treatment; and consequently we must postulate a change in the gelatine. This last is the more probable because even a concentrated nitric acid seems to have no effect on silver bromide suspended in collodion.”

Lüppo-Cramer<sup>1</sup> also believes that a true latent image is not formed by pressure. He says that the pressure phenomena "can be distinguished from real, reduction phenomena because the latter occur throughout the whole film and are not changed in the slightest by any rubbing of the surface."

In the Waterhouse process for making positives with short exposures, it has been shown<sup>2</sup> that thiocarbamide causes some change in unexposed silver bromide such that the bromide is readily reduced by the developer. In fact, the change is so marked that unexposed silver bromide, after treatment with thiocarbamide, will often reduce more rapidly than silver bromide which has been exposed for a short time to light. This might be accounted for by assuming that thiocarbamide removes gelatine less rapidly from silver bromide grains, the more decomposed these latter are. At first sight this seems absurd; but the difficulty disappears if we word the assumption another way and postulate that thiocarbamide acts on the gelatine in the silver bromide grains less rapidly, the more highly brominated the gelatine is. While this is a possible explanation, there are as yet no data to show that it is the right one and it will therefore be better to leave this point to be settled in the laboratories of Messrs. Perley<sup>3</sup> and Frary.<sup>4</sup>

#### Disintegration and the Latent Image

Bredig<sup>5</sup> once suggested that the developability of the latent image may be the result of a physical disintegration of silver bromide by light. This idea has recently been taken up by Lüppo-Cramer<sup>6</sup> who now lays great stress upon it, as a result of experiments with Röntgen rays. There is no doubt that light, or other radiations, may disintegrate silver salts

<sup>1</sup> Phot. Correspondenz, 40, 180 (1903); Jour. Phys. Chem., 15, 327 (1911).

<sup>2</sup> Perley: Jour. Phys. Chem., 13, 655 (1909).

<sup>3</sup> Eighth Internat. Congress Applied Chemistry, 20, 267 (1912).

<sup>4</sup> Jour. Phys. Chem., 17, 32 (1913).

<sup>5</sup> Eder's Jahrbuch der Photographie, 13, 365 (1899).

<sup>6</sup> Das latente Bild, 2 (1911).



and thus produce a developable image. It is possible that this may be an important factor in the case of the Röntgen rays, but I see no reason to suppose that it is of any importance under ordinary photographic conditions.

Lüppo-Cramer<sup>1</sup> thinks that disintegration must be an important factor in what strikes him as a very puzzling phenomenon, namely, that the latent image can be developed by light provided that there be added a solution of a bromine adsorber, such as sodium nitrite. There does not seem to me to be anything about this experiment which calls for any special explanation. The action of a uniform light on a previously exposed plate merely increases the decomposition uniformly, the original differences remaining unchanged. If the action of light is continued long enough, one gets a visible image. The pictures thus obtained are undoubtedly flatter than those obtained by straight development, because the percentage differences in the exposures decrease with the increasing time that the uniform light is allowed to act. It is a question whether Lüppo-Cramer really developed a silver image or not; but there is nothing difficult about the theory of the process.

On the other hand, the disintegration hypothesis may be of importance in the case of the daguerreotype and must be so in the case of Moser's experiments and in the case of Waterhouse's experiments with metal plates. In the case of the daguerreotype the latent image is formed on a plate of silver coated with silver iodide and it is developed by means of mercury vapor. The mercury condenses on the places which have been exposed to the light. The change due to the light is probably a chemical one; but the mercury would also condense if there were a physical disintegration.

In Moser's experiments<sup>2</sup> "a coin was placed on a glass or metal plate and left there for several hours. If one breathes

---

<sup>1</sup> *Das latente Bild*, 10 (1911).

<sup>2</sup> Cf. Namias: *Chimie Photographique*, 105 (1902); *Jour. Phys. Chem.*, 15, 348 (1911).

on the plate where the coin had been, or passes the vapor of iodine or mercury over it, there is a differential condensation on the places which have been in contact with the coin, and an image of the coin is thus formed. What appears more strange is that one can obtain an image and can develop it in this way, even without actual contact between the coin and the plate. It is enough if the coin is near the plate.

"These facts have nothing to do with the action of light; but light will produce similar phenomena. In fact, if one exposes a plate of silver, copper, or glass to an intense light for several hours, one notices that water vapor from the breath, or mercury vapor, will *develop* the parts which have been exposed to the action of light."

"Waterhouse<sup>1</sup> found that silvered glass or copper plates showed distinct traces of a visible image after being exposed to light for an hour or two. This image could be developed with mercury vapor or with a ferrous sulphate solution and silver nitrate (physical development). After a very long exposure a reversed image was obtained on development with mercury. The mercury precipitated on the unexposed places, whereas it precipitated on the high lights when the exposure was shorter."

The actual change in the surface does not need to be large. This is shown clearly in some experiments by Namias.<sup>2</sup>

"In a communication I made to the Chemical Society of Milan in 1897 on the chemical reactions involved in the manufacture of silver mirrors, I made use of a fact which has appeared to me to be a very interesting one. If one takes a carefully cleaned mirror and pours upon it a solution of stannous chloride, even one as dilute as 1 : 100000, and if one then washes the mirror with distilled water, the rate of precipitation of silver from an ammoniacal tartrate solution is much greater with such a mirror. The infinitesimal amount of stannous chloride remaining on such a plate is sufficient

<sup>1</sup> Proc. Roy. Soc., 66, 490 (1900).

<sup>2</sup> Phot. Correspondenz, 42, 155 (1907); Jour. Phys. Chem., 15, 325 (1911).

to make the reduction of the silver considerably easier. The labile equilibrium of the ammoniacal silver tartrate solution is at once upset by the action of infinitely small traces of such a powerful reducing agent as stannous chloride."

Svedberg<sup>1</sup> has shown that ultraviolet light will corrode a silver plate, lying under alcohol, so rapidly as to form a colloidal solution in a few minutes. A slight disintegration of the surface by longer wave-lengths therefore presents no theoretical difficulty. At present we are not able however to explain the reversal that Waterhouse observed with his metal plates. If mercury precipitates more rapidly on a slightly disintegrated surface than on a very smooth one, one would naturally expect it to precipitate still more readily on a surface that was still more disintegrated. This appears not to be true, but the problem is now one in colloid chemistry. It deals with the behavior of roughened surfaces and should be studied quite apart from any action of light.

The general results of this paper are as follows:

1. Since the action of light can be duplicated by any suitable reducing agent, the latent image must be a reduction product.

2. The latent image cannot be free metallic silver because it does not show the chemical reactions of free metallic silver, because it does not show the electrical potential of free metallic silver, because equilibrium is reached very slowly in the electrical measurements, and because the hypothesis cannot be reconciled with the facts of solarization.

3. The latent image cannot consist of a single definite subhalide because no such compound has been prepared, because no satisfactory chemical reactions can be assigned to it, because the prolonged action of light does not yield the pure compound, and because this hypothesis cannot be reconciled with the facts of solarization.

4. The latent image cannot consist of a number of definite compounds because we cannot isolate these in any way or

---

<sup>1</sup> Zeit. Kolloidchemie, 6, 130 (1910).

give any definite proof of their existence or properties, and because it is absurd to assume a number of definite compounds between pure silver bromide and silver bromide containing an excess of 0.5 percent silver when one can account for all the facts much better on the assumption of a phase of continuously varying composition.

5. The latent image is a phase of continuously varying composition, because these products can be prepared synthetically, because this hypothesis accounts for all the chemical reactions of the latent image, and because this hypothesis accounts for the phenomena of solarization.

6. While there is no definite proof as yet whether the latent image consists of silver bromide with adsorbed metallic silver or of silver bromide with an adsorbed hypothetical subhalide, the former hypothesis is the simpler and accounts for the parallelism between the colors of the photohalides and the colors of colloidal silver. The question would be settled if an examination with the ultramicroscope showed that the colors of the photohalides were due to metallic particles.

7. The latent image is identical with the photohalides except as to color. This discrepancy disappears in one set of experiments by Lüppo-Cramer and probably could be made to disappear in other cases if people were to make systematic experiments along this line.

8. The arguments against the decomposition theory are really arguments against the silver nucleus theory and the subhalide theory. They lose their force when applied to the adsorption theory.

9. The reactions of the latent image have been discussed and have been shown to be in accord with the adsorption theory.

10. Photoretrogression is due chiefly to the recombination of halogen with the latent image. The free halogen is apparently adsorbed temporarily either on or in the decomposed grain or the undecomposed grain. It is shown that all the facts of photoretrogression are in accord with this hypothesis.

11. The adsorption theory enables us to account for all the phenomena of solarization. The latent image, which gives rise to a negative under normal development, consists of silver bromide with an excess of about 0.002–0.1 percent silver. When the excess of silver rises above 0.1 percent, we get positives on development. The second negative is not due to metallic silver. There are no data as yet as to the composition at which the second negative begins.

12. The latent images produced by heat, acids, pressure, etc., are not like the latent image produced by light, because they do not necessarily involve a change in the ratio of silver to bromine. They are due to the removal of gelatine, etc., from the silver bromide grain.

13. Under ordinary conditions the mechanical disintegration of silver salts by light is not an important factor in the production of a latent image.

14. Disintegration is the important factor in the images developed on metal surfaces after exposure to light. The reversal on long exposure cannot be accounted for at present. It is, however, really a problem in colloid chemistry and should be studied quite independently of the action of light.

15. Development by means of light and sodium nitrite presents no theoretical difficulties.

*Cornell University*

A METHOD OF DETERMINING "a" OF VAN DER  
WAALS' EQUATION FROM THE SUR-  
FACE TENSION

BY ALBERT P. MATHEWS.

Uncertainty still exists as to the correct value of van der Waals' constant "a," which expresses the cohesive pressure of a fluid.

It is well known that if "a" and "b" are both supposed to be constant, the equation of state may be solved and the relationships obtained:  $a = 3P_c V_c^2$ ;  $V_c = 3b$ ;  $P_c = a/27b^2$ ; and  $T_c = 8a/27bR$ . As this solution depends on the erroneous assumption of the constancy of "b," there is no certainty that any of these expressions is correct; and as a matter of fact, only one of them, *i. e.*,  $P_c = a/27b^2$ , happens to approximate very closely to a correct value. Were these relationships true, the calculation of "a" and "b" from the critical data would be very simple; but as they are not true, except for unknown values of "b," it is necessary to find some other means of computing "a," which does not require a knowledge of the real molecular volume, or "b."

While the formula usually employed for the calculation of "a," *i. e.*,  $a = 27T_c^2/64 \times 273^2 \times P_c$ , gives a value at least approximately correct for non-associating substances of medium molecular complexity, it is still uncertain whether the value thus obtained is correct for very simple substances such as hydrogen, or for very complex substances such as diphenyl methane. The ratio 27/64 can only be justified theoretically if "b" were constant and it is probable that this ratio, 27/64, is not constant, but diminishes as molecular compressibility increases. "b<sub>c</sub>" may not always be the same fraction of V<sub>c</sub>, for it is possible that this fraction also varies with the compressibility of the molecule. All other formulas for "a" are also more or less unsatisfactory. Thus in the formula  $a = 6.28V_c^2P_c$ , the coefficient is not the same for all substances. In the formula  $a = 27b_c^2P_c$  a knowledge

of  $b_c$  is required. The calculation of "a" from the latent heat of vaporization by the formula  $(L - E)/(d_l - D_v) = a/\text{Mol.wt.}$ , where L is the total latent heat and E the part consumed in doing external work, is rendered uncertain by the fact that there is still another part of the heat consumed by the expansion of the molecules from the size they are in the liquid to the size they are in the vapor, and this correction is unknown.

The following method of the computation of "a" from the surface tension is new, so far as I can find, although it is an application of the very first method used to obtain some idea of the amount of the cohesive pressure of a liquid; it does not involve the value "b;" and it is of interest that the results obtained from it are, on the whole, closely similar to those given by the usual formula. It is, I believe, more trustworthy than the formula usually employed. It is a method proposed by the great English philosopher, Thomas Young, in his epoch-making work on Cohesion. In that work, by an insight little short of marvelous, he came to the conclusion that S, the surface tension, was equaled to one-third the total cohesive pressure, multiplied into the radius of action of the cohesive attraction, or  $S = rK/3$ .

Since "a" varies with the volume of the gas taken under standard conditions of temperature and pressure, it would be, in many ways, convenient to have a value which was characteristic of the molecules of each substance and which would be independent of the volume of gas or liquid, or the temperature or pressure to which it was subjected. Such a value is very easily obtained by putting "a" equal to  $N^2M^2K$ , where N is the number of molecules in the volume V; and writing  $V^2$  as  $Nv^2$ , where small v is the volume at the disposal of a single molecule. By dividing by  $N^2$  we have then  $a/V^2 = M^2K/v^2$ . We may call M the mass of cohesion of a molecule, and K is a constant of proportion. This same value may be obtained directly by supposing that molecules attract each other inversely as the fourth power of the distance between their centers, directly as the product of their cohesive masses

and that each molecule attracts only the six surrounding molecules. In another paper I shall show that the value  $M^2K$  is proportional to the two-thirds power of the product of the molecular weight and the number of valences in the molecule. In this paper I wish to show how  $M^2K$  may be derived from the surface tension. The computations are made in absolute units.

The formula,  $S = rK/3$ , states that the surface tension of a liquid is a function of the cohesive pressure of the liquid alone. It is clear, then, that this formula can hold only at very low temperatures, since only at such temperatures can the cohesive pressure in the vapor be neglected. The surface tension, strictly speaking, can not represent the cohesive pressure of the liquid alone, since it is in the very nature of things an expression of the difference in cohesive energy of the liquid and vapor. I shall, then, take the formula as holding at absolute zero, since, if we are going to a temperature in which the vapor may be entirely neglected, it is more convenient to go to the end.

The radius of action of the cohesive attraction, or  $r$ , has been found, both by calculation and by direct measurement, to be, at higher temperatures, very nearly equal to the distance between the molecular centers; and at absolute zero, with the molecules in contact, we may safely assume that " $r$ " is equal to  $v^{1/3}$ .  $K$  is Laplace's constant and is equal to  $a/V^2$ , or  $M^2K/v^2$ . The formula becomes then:  $S = v_o^{1/3}M^2K/3v_o^2 = M^2K/3v_o^{5/3}$ . By multiplying both sides of the equation by  $v_o^{2/3}$  we have,  $Sv_o^{2/3} = M^2K/3v_o$ ;  $v_o$ , the volume at the disposal of one molecule at absolute zero, is, for substances of medium complexity such as ether, very nearly equal to  $v_c$ , the volume of a molecule at the critical temperature, divided by 4. For simpler substances, such as  $O_2$  or  $CO_2$ , the volume  $v_o$  is equal to  $V_c/3.63$ ; and for more complex substances, such as octane, it is  $v_c/4.04$ , or for some even  $v_c/4.10$ . The volume of a molecule is obtained by dividing the volume of a gram mol by  $6.21 \times 10^{23}$ , which is the most probable number of molecules in a gram mol. There is a



difference of opinion as to the value of the coefficient which is given as  $1/3$  by Young,<sup>1</sup> but as  $3/20$  by Rayleigh.<sup>2</sup> As will be shown presently, Young's value is to be preferred.

The value of  $Sv_0^{2/3}$ , the molecular surface tension energy at absolute zero, may be obtained from Eötvös<sup>3</sup> and Ramsay and Shields<sup>4</sup> rule,  $S(mv)^{2/3} = 2.12$  (or  $2.19$ )( $T_c - T - 6$ ).  $S(mv)^{2/3}$  divided by  $N^{2/3}$ , where  $N$  is the number of molecules in one gram mol, equals  $Sv^{2/3}$ . Hence  $Sv^{2/3} = 2.19(T_c - T - 6)/N^{2/3}$ ; and at absolute zero, where  $T$  is zero,  $Sv_0^{2/3} = 2.19(T_c - 6)/N^{2/3} = 3.015 \times 10^{-10}(T_c - 6)$  ergs. It is assumed that the law holds clear to absolute zero.

I have used the coefficient  $2.19$  because I thought it more typical of a non-associating substance, and it is nearer to the value of Eötvös. However, this has given me slightly higher values for "a" than those generally computed, as may be seen in the table. The agreement with other values of "a" seemed on the whole better with this coefficient. It varies slightly with different substances in any case being nearly  $2$ , for some gases like oxygen, and as high as  $2.3$  for very complex substances.  $2.19$  comes close to the mean.

We have then  $Sv_0^{2/3} = M^2K/3v_0 = 3.015 \times 10^{-10}(T_c - 6)$  ergs. So  $M^2K = 9.045 \times 10^{-10}(T_c - 6)v_0$ .

The value  $6^\circ$  subtracted from the critical temperature was established for substances having a critical temperature of about  $400^\circ$ – $480^\circ$  Abs. It would be better perhaps to make it  $1/80$ th of  $T_c$ . The formula corrected thus would be  $M^2K = 9.045 \times 10^{-10}T_c v_0 79/80 = 8.932 \times 10^{-10}T_c v_0$ . As this last correction is uncertain, however, I have uniformly subtracted  $6^\circ$  from the critical temperature, unless it is specifically stated to the contrary.

<sup>1</sup> Young: "An Essay on the Cohesion of Fluids," Philosophical Transactions, 1805. (Collected works, edited by G. Peacock, Vol. I, 1855, p. 418, London.)

<sup>2</sup> Rayleigh: Article on "Capillarity," Encyclopaedia Britannica, xi edition.

<sup>3</sup> Eötvös: Wied. Ann., 27, 458 (1886).

<sup>4</sup> Ramsay and Shields: Zeit. phys. Chem., 12, 433 (1893).

As already mentioned there is an uncertainty whether the coefficient should be  $\frac{1}{3}$ , as found by Young, or  $\frac{3}{20}$ , as found by Rayleigh. As I was unable to decide which of the values of the coefficient was preferable, I tried them both, and Young's value gives a consistent result. Rayleigh's gives an impossible result, the cohesive pressure computed by it being more than double what it ought to be, so that if it be substituted in van der Waals' equation,  $b_c$  must be taken very large and at what are impossible values. For example,  $b_c$  must be  $0.748V_c$ , or nearly three-fourths of the critical volume, if the coefficient  $\frac{3}{20}$  is used. Such a value for "b" is impossible if the atoms retain their uniform size in the molecules, or if they change very little, since the intramolecular cohesion is so much greater than the intermolecular that the greater part of the gain in volume in coming from zero to the critical temperature must be in the spaces between the molecules, rather than within them. If the atoms are incompressible and make up one-fourth of the total volume, then three-fourths of the critical volume will be free space. If  $b_c = 0.75V_c$  and the atomic volume is  $0.25V_c$ , then free space within the molecule will be  $0.5V_c$ , leaving only a total of  $0.25V_c$  for the inter-molecular space. In other words, the space within the molecules would have enlarged more in passing from zero to the critical temperature than the space between the molecules. Such a result is impossible. With Young's formula, however,  $b_c = 0.5V_c$  approximately; if the atomic volume is  $0.25V_c$ , then the free space within the molecules would be  $0.25V_c$  and between the molecules,  $0.5V_c$ , which is a more probable result.

The following values of  $M^2K$  were obtained by the formula,  $M^2K = v_c \times 9.045 \times 10^{-16}(T_c - 6)/4$ :

Substance	$\log_{10}M^2K$
Pentane	-35.71919
Isopentane	-35.70663
Methyl acetate	-35.61791
Ether	-35.67593

With the values thus found for four of the most carefully investigated non-associating substances, the value of the real molecular volume, or  $b_c$ , at the critical temperature was computed by substituting in van der Waals' equation, with the following result:

Substance	$V_c$	$b_c$	$V_c/b_c$
Ether	282.23	135.81	2.078
Pentane	309.94	149.44	2.074
Methyl acetate	227.55	109.09	2.086
Isopentane	307.30	148.30	2.072

By substituting the values of  $M^2K$  derived in the foregoing manner from the surface tension,  $b_c$  turns out to be the same fraction of  $V_c$  for the three best investigated, normal substances, ether, pentane and iso-pentane, a result anticipated from van der Waals' reduced, characteristic equation.  $V_c$  is, therefore,  $2.074b_c$ . The value thus obtained for  $b_c$ , namely  $V_c/2.074$ , is very close to that calculated by van der Waals' from a value of "a" obtained from the coefficient of compressibility. He thus obtained the value  $V_c = 2.03b_c$ . Other estimates of  $b_c$  made by him bring it about 2.08. This value of  $b_c$ , moreover, is inherently probable, the value of  $b_c$  necessarily being close to  $V_c/2$ , and presumably a little less than this.

We may now, with this value of  $b_c$  fixed, calculate by substitution in van der Waals' equation the value of the coefficients in the formulas given on page 154 in place of those derived when "a" and "b" were considered constant.

The following relationships were obtained:<sup>2</sup>

- 1  $a/P_c = 6.284V_c^2$ ; in place of  $a/P_c = 3V_c^2$ .
- 2  $V_c = 2.074b_c$ ; in place of  $V_c = 3b_c$ .
- 3  $P_c = a/27.02b_c^2$ ; in place of  $P_c = a/27b_c^2$ .
- 4  $T_c = 7.769a/27.02Rb_c$ ; in place of  $T_c = 8a/27Rb_c$ .
- 5  $b_c + RT_c/P_c = 4.243V_c$ ; in place of  $b_c + RT_c/P_c = 3V_c$ .
- 6  $P_cV_c/T_c = R2.074/7.769 = 21.92$ ; in place of  $P_cV_c/T_c = 3R/8 = 30.80$ .
- 7  $RT_c/P_cV_c = 3.75$ .

<sup>1</sup> Van der Waals: Proc. Roy. Acad. Sci., Amsterdam, 3, 583 (1901).

<sup>2</sup> Compare with van der Waals: Proc. Roy. Acad. Sci., Amsterdam, 13, 1211 (1912).

TABLE I

Values of  $M^2K$ , as calculated by different formulas, expressed in absolute units. (1)  $M^2K = V_c T_c 3.594 \times 10^{-6}$ ; (2)  $M^2K = P_c V_c^2 1.6296 \times 10^{-47}$ ; (3)  $M^2K = 9.045 \times 10^{-16} (T_c - 6)^2$ ; (4)  $M^2K = 27 T_c^2 / 64 \times (273)^2 P_c N^2$ . Critical data of all substances those of Young.

Substances	Formulas			
	1	2	3	4
SnCl <sub>4</sub>	7.476 × 10 <sup>-35</sup>	7.538 × 10 <sup>-35</sup>	7.499 × 10 <sup>-35</sup>	7.083 × 10 <sup>-35</sup>
Diisobutyl	9.522 × 10 <sup>-35</sup>	9.411 × 10 <sup>-35</sup>	9.541 × 10 <sup>-35</sup>	9.202 × 10 <sup>-35</sup>
Hexamethylene	6.105 × 10 <sup>-35</sup>	6.201 × 10 <sup>-35</sup>	6.118 × 10 <sup>-35</sup>	5.742 × 10 <sup>-35</sup>
Diisopropyl	6.415 × 10 <sup>-35</sup>	6.457 × 10 <sup>-35</sup>	6.421 × 10 <sup>-35</sup>	6.089 × 10 <sup>-35</sup>
Isopentane	5.090 × 10 <sup>-35</sup>	5.132 × 10 <sup>-35</sup>	5.089 × 10 <sup>-35</sup>	4.821 × 10 <sup>-35</sup>
Methyl formate	2.992 × 10 <sup>-35</sup>	2.893 × 10 <sup>-35</sup>	2.993 × 10 <sup>-35</sup>	2.992 × 10 <sup>-35</sup>
Carbon tetrachloride	5.514 × 10 <sup>-35</sup>	5.650 × 10 <sup>-35</sup>	5.526 × 10 <sup>-35</sup>	5.142 × 10 <sup>-35</sup>
Fluorbenzene	5.453 × 10 <sup>-35</sup>	5.416 × 10 <sup>-35</sup>	5.465 × 10 <sup>-35</sup>	5.245 × 10 <sup>-35</sup>
Chlorbenzene	6.993 × 10 <sup>-35</sup>	6.981 × 10 <sup>-35</sup>	7.017 × 10 <sup>-35</sup>	6.692 × 10 <sup>-35</sup>
Brombenzene	7.791 × 10 <sup>-35</sup>	7.712 × 10 <sup>-35</sup>	7.810 × 10 <sup>-35</sup>	7.522 × 10 <sup>-35</sup>
Iodobenzene	9.093 × 10 <sup>-35</sup>	9.070 × 10 <sup>-35</sup>	9.135 × 10 <sup>-35</sup>	8.711 × 10 <sup>-35</sup>
Benzene	5.170 × 10 <sup>-35</sup>	5.188 × 10 <sup>-35</sup>	5.181 × 10 <sup>-35</sup>	4.921 × 10 <sup>-35</sup>
Methyl butyrate	6.770 × 10 <sup>-35</sup>	6.535 × 10 <sup>-35</sup>	6.784 × 10 <sup>-35</sup>	6.698 × 10 <sup>-35</sup>
Methyl isobutyrate	6.580 × 10 <sup>-35</sup>	6.413 × 10 <sup>-35</sup>	6.591 × 10 <sup>-35</sup>	6.448 × 10 <sup>-35</sup>
Hexane (normal)	6.697 × 10 <sup>-35</sup>	6.583 × 10 <sup>-35</sup>	6.704 × 10 <sup>-35</sup>	6.508 × 10 <sup>-35</sup>
Heptane (normal)	8.289 × 10 <sup>-35</sup>	8.099 × 10 <sup>-35</sup>	8.303 × 10 <sup>-35</sup>	8.103 × 10 <sup>-35</sup>
Octane (normal)	10.025 × 10 <sup>-35</sup>	9.766 × 10 <sup>-35</sup>	10.050 × 10 <sup>-35</sup>	9.826 × 10 <sup>-35</sup>
Ether (ethyl)	4.736 × 10 <sup>-35</sup>	4.685 × 10 <sup>-35</sup>	4.797 × 10 <sup>-35</sup>	4.574 × 10 <sup>-35</sup>
Pentane	5.238 × 10 <sup>-35</sup>	5.238 × 10 <sup>-35</sup>	5.239 × 10 <sup>-35</sup>	5.004 × 10 <sup>-35</sup>
Ethyl formate	4.183 × 10 <sup>-35</sup>	4.047 × 10 <sup>-35</sup>	4.188 × 10 <sup>-35</sup>	4.130 × 10 <sup>-35</sup>
Methyl acetate	4.144 × 10 <sup>-35</sup>	3.961 × 10 <sup>-35</sup>	4.149 × 10 <sup>-35</sup>	4.142 × 10 <sup>-35</sup>
Propyl formate	5.500 × 10 <sup>-35</sup>	5.357 × 10 <sup>-35</sup>	5.510 × 10 <sup>-35</sup>	5.395 × 10 <sup>-35</sup>
Ethyl acetate	5.377 × 10 <sup>-35</sup>	5.131 × 10 <sup>-35</sup>	5.397 × 10 <sup>-35</sup>	5.383 × 10 <sup>-35</sup>
Methyl propionate	5.371 × 10 <sup>-35</sup>	5.177 × 10 <sup>-35</sup>	5.377 × 10 <sup>-35</sup>	5.322 × 10 <sup>-35</sup>
Propyl acetate	6.810 × 10 <sup>-35</sup>	6.521 × 10 <sup>-35</sup>	6.823 × 10 <sup>-35</sup>	6.791 × 10 <sup>-35</sup>
Ethyl propionate	6.750 × 10 <sup>-35</sup>	6.483 × 10 <sup>-35</sup>	6.772 × 10 <sup>-35</sup>	6.711 × 10 <sup>-35</sup>
Propyl alcohol	4.234 × 10 <sup>-35</sup>	3.989 × 10 <sup>-35</sup>	4.241 × 10 <sup>-35</sup>	4.293 × 10 <sup>-35</sup>

The value of 21.92 thus obtained for  $P_c V_c / T_c$  corresponds with the value determined from Young's very careful observations on the critical data of some non-associating substances.

The values obtained for M<sup>3</sup>K by the use of the foregoing formulas, the surface tension formula, and the ordinary formula, when applied to the critical data of the substances so carefully investigated by Young<sup>1</sup> are given in Table I.

The value of "a" in atmospheres for 1 cc of a gas under standard conditions of pressure and temperature may be obtained from any of the values in this table by multiplying by  $7.573 \times 10^{32}$ .

A comparison of columns 3 and 4 of Table I will show that the values obtained by the surface tension formula, while on the whole closely similar to those obtained by the ordinary formula given in column 4, differ, nevertheless, in some instances quite markedly from them. The values of column 3, on the other hand, are almost identical with those of column 1. Owing to the fact that there is less uncertainty about the factors used in computing "a" from the surface tension than from the usual formula, I believe the surface tension values are to be preferred. If the coefficient in the surface tension formula had been taken as 2.12 instead of 2.19, all the values of column 3 would need to be reduced proportionally, and the values in columns 1 and 2 would also be lower. That the values of "a" computed in this way from the surface tension are the more accurate is indicated also by the fact that these values exhibit most clearly and with fewest exceptions the relation of cohesion to molecular weight and the number of valences in the molecule, as is set forth in a subsequent paper.

*University of Chicago*

<sup>1</sup> Young: "The Vapor Pressures, Specific Volumes, Heats of Vaporization and Critical Constants of 30 Pure Substances," *Proc. Roy. Dublin Soc.*, 12, 374-443 (1910).

## STUDIES OF THE ELECTRICAL CONDUCTANCE OF NON-AQUEOUS SOLUTIONS

BY LEON IRWIN SHAW

In the study of aqueous solutions, their conductance has received considerable attention, but similar work on the conductance of non-aqueous solutions is entirely disproportionate to their importance. A further study of the latter will aid materially in forming an explanation of the results obtained in the study of both types of solutions.

As stated by Kahlenberg and Lincoln<sup>1</sup> conductance was first studied in aqueous solutions, then in solutions in which the solvent was a mixture of water and some other solvent, and lastly in solutions that contain no water. They give a bibliography of the work done up to that time.

The earlier theories have been taken up by Kahlenberg and Lincoln and by Lincoln<sup>2</sup> in their articles. Some of these will also be considered in this paper after the experimental data have been presented. Lincoln shows that several of the theories presented to explain conductance are untenable. In the present investigation other examples have been found where these theories will not explain the observed facts. These will be considered in detail later.

Kahlenberg and Lincoln<sup>3</sup> made qualitative measurements of the conductivities of four salts (ferric chloride, antimony trichloride, bismuth trichloride, and mercuric chloride) in seventy-two organic solvents of very varying types. The quantitative work recorded in the first article was done in solutions of ferric chloride, antimony trichloride, arsenic trichloride, phosphorus trichloride, cuprous chloride, stannous chloride, and bismuth trichloride. The solvents employed in preparing the solutions were methyl alcohol, ethyl alcohol, acetone, ethyl acetate, ethyl acetoacetate, benzaldehyde, and

<sup>1</sup> Jour. Phys. Chem., 3, 12 (1899).

<sup>2</sup> Ibid., 3, 457 (1899).

<sup>3</sup> Loc. cit.

nitrobenzene. In the second article qualitative experiments on the conductance of eighteen salts were made in twenty-nine solvents, and then quantitative measurements were made using six different salts and eighteen different solvents. However, measurements were not made for each of six different salts in all of the eighteen different solvents, but only for certain salts in certain solvents.

As a result of this work they showed among other things that the electrolytic dissociation theory as promulgated to explain the electrical conductance in aqueous solutions apparently can not be applied in its present form to explain the conductance of non-aqueous solutions.

Paul Walden has carried on the most extensive research work on conductance in non-aqueous solutions since that of Kahlenberg and Lincoln. The results of his investigations appeared in ten articles from 1903 to 1908.<sup>1</sup>

In the first two of these articles he considers the relation between the dielectric constant of the solvent and the dissociating power of the latter. These first two articles will be the only ones considered, because the others deal with the relation of other properties to the dissociative power. Walden's work consisted of the study of the dissociative power of forty-nine solvents with one solute, tetraethyl ammonium iodide (in a few exceptional cases other solutes were used), and on these observations he generalized, and concluded that the dissociative power of a solvent is directly parallel to the dielectric constant, in harmony with the Nernst-Thomsen rule. To get the degree of dissociation, it was necessary for him, in most cases, to calculate the value of the conductance at infinite dilution, as no limiting value could be obtained experimentally. He disagrees with Dutoit and Aston<sup>2</sup> that only those solvents, that are associated, yield conducting solutions. By making his conductivity measurements at different temperatures, he also shows that the product of the

<sup>1</sup>Zeit. phys. Chem., 46, 103 (1903); 54, 131; 55, 207, 281, 683 (1906); 58, 479; 59, 192, 385; 60, 87 (1907); 61, 633 (1908).

<sup>2</sup>Comptes rendus, 125, 240 (1897).

conductivity at infinite dilution (calculated) multiplied by the temperature coefficient is nearly constant. Many other points are also taken up.

A bibliography of the work on non-aqueous and mixed solvents is given by Walden in his first article, "Organic Solvents and Ionizing Media."<sup>1</sup> In the next ten articles he has kept the bibliography up-to-date.

The solvents used by Walden represent thirteen different types of compounds, namely, alcohols, aldehydes, ketones, acids, acid anhydrides, chlorides, bromides, amides, esters, nitriles, thiocyanides, thiocarbamides, and nitro compounds. He purified the solvents by distillation and other means, until a product of minimum conductance was obtained. He then concluded that the solvent was pure. This point will be taken up after the presentation of the experimental data.

As before stated, Walden, in most of his researches, used only one solute, namely, tetraethyl ammonium iodide, in a number of solvents. He arranged these solvents in a list according to their decreasing dielectric constants, to see if there was any regular agreement between the dielectric constant and the dissociative power, and found *for this one solute*, that it was always the case, that the greater the dielectric constant the greater the dissociative power.

The purpose of the present investigation was to find out if other solutes would act in an analogous manner to tetraethyl ammonium iodide; that is to say, if we took another salt, and dissolved it in the same solvents, if the molecular conduction of this given salt, in the different solvents, at a given dilution, would be highest in the solvent of the highest, and lowest in the solvent of the lowest dielectric constant. Three salts were therefore taken, and the conductance of their solutions in nine solvents was measured.

The solvents used in the present investigation are as follows: (1) methyl alcohol; (2) salicylic aldehyde and

---

<sup>1</sup> Loc. cit.



benzaldehyde; (3) acetic acid anhydride; (4) acetyl chloride; (5) ethyl acetate and dimethyl sulphate; (6) benzo-nitrile; (7) acetone; (8) aniline; (9) epichlorhydrin. It will be noted that they represent nine different types of organic compounds. The solutes used in the quantitative work were lithium chloride, mercuric chloride, and iodine. In the qualitative tests, cadmium iodide, cobalt carbonate, cuprous iodide, ferric chloride, mercuric iodide, mercurous chloride, nickel carbonate, antimony trichloride, cuprous chloride, zinc acetate and lead sulphate were also tried.

The solvents used were all of c. p. grade, prepared by Merck, Kahlbaum, or Schuchardt, except the ethyl acetate, which was a pure sample that had been prepared by Professor Kahlenberg. They were each first dried by an appropriate drying agent, and then distilled. Thus a fraction of very constant boiling point was obtained. This distillate was then further treated and distilled from a flask, to which a hard glass condenser was connected by means of a ground glass joint. In exceptional cases a block tin condenser or a platinum still and condenser was used. Thus a liquid of less conductance could sometimes be obtained. The distillate was always protected from the water and carbon dioxide of the air by means of soda-lime and calcium chloride. The distillation was always repeated in a given apparatus, until a minimum conductance was obtained for the substance. In some cases this was less than that found by other recent investigators. If the first distillate was condensed in glass, a tin or platinum condenser was then substituted, and thus in some cases a distillate of constant and lower conductance was obtained. All condensers, flasks, etc., used in this work were cleaned thoroughly with the solvents best adapted to remove the substance last used therein, then they were rinsed with distilled water, and dried in a current of pure air.

The method of purification of each of the solvents will now be taken up. The numbers given as the conductance of the purified solvents indicate the number of divisions of the deflection of the galvanometer needle. For guidance as to

what these scale divisions represent approximately in reciprocal ohms the following table is appended:

TABLE I

Spaces	Reciprocal ohms
0.50	$0.5 \times 10^{-7}$
0.75	$0.5 \times 10^{-8}$
1.00	$0.5 \times 10^{-5}$
8.00	$0.5 \times 10^{-4}$

The cell used was one that will be referred to as the qualitative cell. It was a platinum crucible with a tightly fitting cover and a polished platinum electrode inside. A direct current was used and the conductance was measured by noting the initial deflection of the galvanometer needle.

Methyl alcohol. Merck's C. P. product was used. After standing three weeks over anhydrous copper sulphate it was distilled off, and condensed in glass. The portion boiling at  $63.5^{\circ}$  and 744 mm was saved. This was treated with sodium and distilled; then with anhydrous copper sulphate; then again with sodium and distilled, each time rejecting the first and last eighth. This then exhibited a constant conductance represented by 5.0 divisions, in making the qualitative tests.

Salicylic aldehyde (Kahlbaum's C. P.) was dried by means of anhydrous copper sulphate, and distilled from it three times condensing in glass. The observed conductance was 0.5 division.

Acetic acid anhydride was allowed to stand over fused sodium acetate for three weeks, and then distilled from this four times, condensing in glass. The conductance was 1.0 divisions.

Acetyl chloride. Merck's C. P. product was distilled twice and condensed in glass. Its conductance was 1.5 divisions.

Ethyl acetate from Professor Kahlenberg was distilled three times. It had a very constant boiling point,  $75^{\circ}$  at 744 mm, and showed a conductance 0.5 division.

Dimethyl sulphate. Schuchardt's C. P. was distilled being condensed in a block tin condenser. The boiling point was constant at  $188^{\circ}$  and 751 mm. The distillation was repeated seven times. The substance would blacken each time on heating. A constant conductance of 25.0 divisions was finally secured. On analysis for the sulphate radical, it was found to contain a large percentage of sulphuric acid, and therefore it was a constant boiling mixture rather than a definite compound.

Benzonitril. Schuchardt's C. P. article was dried for three weeks over anhydrous copper sulphate, and distilled, using a glass condenser. It had a very constant boiling point. After four distillations the conductance was constant, the galvanometer deflection being 3.0 divisions.

Acetone. Merck's highest purity was kept over potassium hydroxide for 2 days. It turned brown. It was distilled off, and the portion boiling between  $54^{\circ}$  and  $56^{\circ}$  was treated with fused calcium chloride and heated on the steam bath for 8 weeks, a reflux condenser being attached. It was then distilled, using a tin condenser. The conductance was constant 1.5 divisions after three distillations. The liquid was then treated with anhydrous copper sulphate, and condensed in glass, when, after three distillations, the conductance was constant at 0.75 divisions.

Aniline. Merck's highest purity product was treated with potassium hydroxide for 2 weeks and distilled, when a straw-colored distillate was obtained. After five distillations from anhydrous copper sulphate the distillate was colorless, and had a conductance so low that no movement of the galvanometer needle could be detected.

Epichlorhydrin. Kahlbaum's C. P. product was treated with anhydrous copper sulphate for 2 weeks, and distilled, being condensed in block tin. It had a constant boiling point of  $112^{\circ}$  at 744 mm. After distilling three times, the distillate was colorless, and had a constant conductance, the galvanometer indicating 0.5 division. This could not be changed by

repeated treatments and distillations, using either a glass or a platinum still.

**Benzaldehyde.** Kahlbaum's C. P. product was distilled three times in a current of carbon dioxide. It was immediately stoppered with the flask full of gas. On standing a few days autooxidation would decompose the product, giving crystals of benzoic acid, for which reason it was not used in this investigation.

The solutes used were all of the anhydrous C. P. variety of standard makes. For the qualitative tests they were dried to constant weight, in an air bath, at as high a temperature as they would stand without decomposition.

For the quantitative work the solutes were purified as follows: Mercuric chloride, Schuchardt's C. P. product, was sublimed twice, and the fine crystalline sublimate was used. Lithium chloride, Merck's recrystallized C. P. preparation, was heated in a mortar, in an air bath, for 3 hours, to  $210^{\circ}$ , when it was removed and pulverized while hot. This was repeated four times. During the last two treatments there was no caking of the salt. On dissolving in water, the salt showed neither alkaline nor acid properties toward phenolphthalein. Iodine. A solution of Kahlbaum's C. P. potassium iodide was decomposed by chlorine. The iodine thus obtained was washed and dried, after which it was sublimed three times with an admixture of potassium iodide. It was then allowed to stand in a desiccator over sulphuric acid for 2 days during which time it lost no weight.

Qualitative tests were made on the saturated solutions to see if the various solutes dissolved in the different solvents, and yielded conducting solutions. In these tests the qualitative cell was used. As a result of these tests, the three substances before mentioned were selected as the most suitable for the work in this investigation. Lithium chloride and mercuric chloride represent true salts, while the iodine is an element. The results of these experiments are given below together with other data.

All three of the solutes did not dissolve in each of the nine

solvents, but in every case where solution resulted, the quantitative measurements of the conductance of the solutions were made. The measurements were all made at 25° C, in a cell of the Arrhenius type, by the Kohlrausch method. A resistance box of a maximum of 33,330 ohms was available, and thus small conductances could be measured with accuracy.

To insure constant temperature, the cell was immersed in a thermostat bath regulated to within 0.005°. The solutions were made by weighing into a weighing bottle an amount of solute a little less than that which would dissolve in 10 cc of the solvent. This amount had to be ascertained by an independent preliminary experiment. The solvent (at 25°) was then put into the weighing bottle, and the latter was immersed to the neck in the thermostat. To insure accuracy, the pipettes were kept in a glass cylinder immersed in the bath, and stoppered to keep out moisture. Five cubic centimeters of the solution were then transferred to the cell and the conductance measured. An equal volume of pure solvent was then introduced, and the conductance measured again. Five cubic centimeters of the solution were then withdrawn, an equal volume of pure solvent was added, and the conductance measured again. This process was repeated till accurate measurements could no longer be made.

The plates of the cell were coated with platinum black. They were 15 mm in diameter and 2 mm apart. The cell, between each different solution, was washed with the proper solvent, then with carbon dioxide free water, after which it was dried in pure air. The air was purified by drawing it through the following train: Acidified permanganate, sulphuric acid, soda-lime, calcium chloride, a heated tube, soda-lime and calcium chloride. The constant of the cell was re-determined with  $N/100$  KCl after each solvent had been used, and was not found to change appreciably.

The resistance of each solution was measured at least three times, with different resistances in the rheostat. In only a few cases was there any disagreement, and then a large number of measurements were made and the average taken.

The results of the qualitative measurements will now be given. In the following Tables, II and III, giving the qualitative results, *s* stands for soluble, *ss* for slightly soluble, *d* for decomposed by solvent, *os* for conductivity too large to measure, *h* for conductance of the solution is no greater than that of the pure solvent, *p* for conductance of pure solvent, being the scale divisions of the galvanometer, *DC* for dielectric constant of pure solvent. The values of the scale divisions of the galvanometer in reciprocal ohms are given in Table I.

TABLE II

Solvent	<i>p</i>	CdI <sub>2</sub>	CoCO <sub>3</sub>	Cu <sub>2</sub> I <sub>2</sub>	FeCl <sub>3</sub>	LiCl	HgCl <sub>2</sub>	DC
Epichlorhydrin	0.5	9	4	1	9	<i>h</i>	8	26.0
Dimethyl sulphate	25.0	<i>h</i>	<i>h</i>	<i>h</i>	<i>s</i>	<i>h</i>	<i>s</i>	..
Acetone	0.75	<i>os</i>	8	6	<i>os</i>	<i>os</i>	<i>os</i>	21.0
Methyl alcohol	5.0	<i>os</i>	35	15	15	40	6	32.5
Benzonitril	3.0	<i>h</i>	<i>h</i>	<i>h</i>	10	5	9	26.0
Acetyl chloride	1.5	2	5	13	<i>os</i>	<i>h</i>	5	15.5
Acetic anhydride	1.0	<i>h</i>	20	<i>h</i>	<i>os</i>	<i>os</i>	4	..
Aniline	0.0	1	<i>h</i>	0.5	4	0.5	<i>h</i>	7.5
Ethyl acetate	0.5	20	<i>h</i>	2	<i>os</i>	8	10	6.5
Salicylaldehyde	0.5	3	<i>h</i>	3	<i>os</i>	6	4	13.9

TABLE III

Solvent	HgI <sub>2</sub>	HgCl	NiCO <sub>3</sub>	SbCl <sub>3</sub>	CuCl <sub>2</sub>	Zn(C <sub>2</sub> H <sub>3</sub> O <sub>2</sub> ) <sub>2</sub>	PbSO <sub>4</sub>	<i>I</i>
Epichlorhydrin	15.0	<i>h</i>	<i>s</i>	<i>d</i>	<i>d</i>	10	3	25
Dimethyl sulphate	<i>h</i>	<i>h</i>	<i>h</i>	<i>os</i>	<i>h</i>	<i>h</i>	<i>h</i>	<i>h</i>
Acetone	18	10	4	<i>os</i>	<i>os</i>	9	10	<i>os</i>
Methyl alcohol	6	15	6	20	<i>os</i>	<i>os</i>	20	20
Benzonitril	<i>h</i>	<i>h</i>	<i>h</i>	6	15	<i>os</i>	<i>h</i>	15
Acetyl chloride	3	3	12	<i>os</i>	17	30	18	25
Acetic anhydride	18	15	<i>h</i>	30	6	18	12	<i>os</i>
Aniline	0.5	<i>h</i>	<i>h</i>	10	<i>h</i>	<i>h</i>	<i>h</i>	20
Ethyl acetate	8	10	<i>h</i>	<i>os</i>	2	<i>h</i>	<i>h</i>	20
Salicylaldehyde	3	<i>h</i>	<i>h</i>	15	15	1	1	10

The values of the dielectric constant here given are taken from the compilation in Walden's second article<sup>1</sup> except those for aniline and ethyl acetate which are Tereschin's figures.

Looking over the results in Tables II and III, it appears that methyl alcohol and acetone yield the greatest number of well conducting solutions. Acetyl chloride and acetic anhydride are the next best for this purpose with the salts investigated. This might be expected, for methyl alcohol has a high dielectric constant. However, both epichlorhydrin and benzonitril have a higher dielectric constant than acetone, and still do not show as great "dissociating power" as exemplified in forming conducting solutions.

Aniline which has a coefficient of association of 1.05 according to Ramsay and Shields<sup>2</sup> gives solutions of higher resistance than ethyl acetate or acetic anhydride in case of all of the fourteen salts investigated. Ethyl acetate and acetic anhydride each have coefficients of association of 0.99 according to Ramsay and Shields.<sup>1</sup> Therefore it can not be held with Dutoit and Aston<sup>3</sup> that only those solvents that are polymerized yield conducting solutions. This has been shown before by Kahlenberg and Lincoln<sup>1</sup> and by Walden.<sup>1</sup>

Many of the solvents that are saturated compounds, yield better conducting solutions than aniline which is surely unsaturated. Therefore the theory of Brühl<sup>4</sup> that only those solvents that are unsaturated yield conducting solutions, is untenable. This was also shown by Kahlenberg and Lincoln.<sup>1</sup>

The results of the quantitative measurements will now be given. In the tables  $\kappa$  represents the specific conductance in reciprocal ohms,  $v$  the volume in liters in which 1 gram

---

<sup>1</sup> Loc. cit.

<sup>2</sup> Jour. Chem. Soc., 63, 1089 (1893).

<sup>3</sup> Comptes rendus, 125, 240 (1897).

<sup>4</sup> Zeit. phys. Chem., 18, 514 (1895); 27, 317 (1898); Ber. chem. Ges. Berlin, 30, 163 (1897).

molecule is contained, and  $u$  the molecular conductance.

#### Solutions in Epichlorhydrin

The solvent was purified as before stated. It had a specific conductance of  $0.61 \times 10^{-7}$  reciprocal ohms.

TABLE IV  
Mercuric chloride

$x$	$v$	$u$
$2.48 \times 10^{-4}$	2.0	0.496
$1.97 \times 10^{-4}$	4.0	0.788
$1.39 \times 10^{-4}$	6.0	0.834
$0.95 \times 10^{-4}$	12.0	1.140
$0.69 \times 10^{-4}$	24.0	1.656

TABLE V  
Iodine

$x$	$v$	$u$
$5.35 \times 10^{-6}$	2.7	0.1045
$5.21 \times 10^{-6}$	5.4	0.0255
$3.01 \times 10^{-6}$	10.8	0.0326
$2.14 \times 10^{-6}$	21.6	0.0464
$1.39 \times 10^{-6}$	43.3	0.0603
$1.15 \times 10^{-6}$	86.7	0.0997
$0.93 \times 10^{-6}$	173.4	0.1613
$0.80 \times 10^{-6}$	346.8	0.2775
$0.76 \times 10^{-6}$	693.7	0.2813

Lithium chloride was insoluble in epichlorhydrin and so could not be tested.

#### Solutions in Acetone

The solvent was purified as before stated. It had a specific conductance of  $0.37 \times 10^{-8}$  reciprocal ohms.



TABLE VI  
Mercuric chloride

$x$	$\nu$	$\mu$
$4.96 \times 10^{-4}$	0.47	0.2366
$3.62 \times 10^{-4}$	0.95	0.3453
$2.28 \times 10^{-4}$	1.90	0.4350
$1.36 \times 10^{-4}$	3.81	0.5182
$7.95 \times 10^{-5}$	7.63	0.6073
$4.45 \times 10^{-5}$	15.26	0.6809
$2.69 \times 10^{-5}$	30.5	0.8229
$1.63 \times 10^{-5}$	61.0	0.9959
$1.01 \times 10^{-5}$	122.0	1.2322
$6.85 \times 10^{-6}$	244.0	1.6055
$4.92 \times 10^{-6}$	488.0	2.4010
$3.87 \times 10^{-6}$	977.0	3.7810
$3.03 \times 10^{-6}$	1,950.0	5.9206

TABLE VII  
Iodine

$x$	$\nu$	$\mu$
$1.33 \times 10^{-2}$	1.82	24.07
$1.16 \times 10^{-2}$	3.64	42.23
$0.92 \times 10^{-2}$	7.28	67.16
$0.50 \times 10^{-2}$	14.56	73.00
$0.40 \times 10^{-2}$	29.13	116.00
$0.33 \times 10^{-2}$	58.27	192.00

It is to be noted that in no case does the molecular conductance show a limiting value on dilution, but increases steadily even at very high dilutions. Therefore it is impossible to determine the conductivity at infinite dilution. Consequently in these cases the "degree of dissociation," at any given dilution, can not be found by dividing the conductance at any given dilution, by the conductance at infinite dilution.

As another example which shows that Ostwald's or Rudolphi's dilution law does not always hold, is cited the case of lithium chloride in acetone. Here the molecular conductance first increases, than decreases, and then increases again, as the solution is diluted farther.

TABLE VIII  
Lithium chloride

$x$	$v$	$u$
$6.6 \times 10^{-4}$	3.5	2.36
$5.1 \times 10^{-4}$	7.1	3.66
$3.9 \times 10^{-4}$	14.2	5.63
$2.9 \times 10^{-4}$	28.5	8.29
$2.0 \times 10^{-4}$	57.1	11.59
$1.4 \times 10^{-4}$	114.0	15.76
$0.94 \times 10^{-4}$	228.0	21.47
$0.65 \times 10^{-4}$	456.0	29.69
$0.41 \times 10^{-4}$	913.0	37.46
$0.26 \times 10^{-4}$	1,830.0	47.51
$0.15 \times 10^{-4}$	3,650.0	54.83
$0.71 \times 10^{-5}$	7,310.0	51.89
$0.30 \times 10^{-5}$	14,600.0	43.96
$0.26 \times 10^{-5}$	29,200.0	76.02
$0.18 \times 10^{-5}$	58,400.0	105.25
$0.15 \times 10^{-5}$	117,000.0	175.00

Walden in his work<sup>1</sup> subjected a solvent to one and the same definite treatment repeatedly, until a definite minimum conductance was obtained, and then concluded that the substance was pure. He said that the conductance was due to ionization of the solvent. I have obtained both acetone and epichlorhydrin of less conductance than that obtained by Walden. In the case of the acetone a constant minimum conductance was obtained by one given treatment, but when another treatment was employed, a still lower conductance was obtained. These and other cases point to the probability not of "self dissociation" but of constant impurities.

According to Walden, the solvent power for tetraethyl ammonium iodide diminishes as the dielectric constant increases. That this is not the case for all solutes is shown by the fact that lithium chloride dissolves readily in acetone (dielectric constant 21.0), but not in acetyl chloride (dielectric constant 15.5).

Looking over the results in the tables of the quantitative

<sup>1</sup> Loc. cit.

measurements, it will be noted that at a given dilution, say 1 gram molecule in two liters, iodine shows a higher conductance in acetone than in epichlorhydrin. The dielectric constant of the first, however, is lower than that of the second. On the other hand, for mercuric chloride, in the same solvents, at the same dilutions, the reverse is true. In order to compare the results more easily the following tables are given. (See Table IX.)

TABLE IX  
Mercuric chloride

$\nu$	$\kappa$ in acetone	$\kappa$ in epichlorhydrin
2	0.435	0.496
4	0.518	0.788
8	0.607	0.900
16	0.689	1.200

Iodine

$\nu$	$\kappa$ in acetone	$\kappa$ in epichlorhydrin
2	24	0.013
4	42	0.023
8	67	0.028
16	75	0.039

The dielectric constant of acetone equals 21.0, that of epichlorhydrin 26.0. In Table IX only approximate values are given for  $\kappa$  at the stated dilutions. As before mentioned, mercuric chloride shows a higher conductance at a given dilution in epichlorhydrin than in acetone, while of iodine the reverse is true. (See Table IX.) Consequently, if in this case we arrange our solvents in the order of their decreasing dielectric constants as Walden did, we find that in the case of mercuric chloride, the greater the dielectric constant of the solvent, the greater the conductance. This is parallel with Walden's results with tetraethyl ammonium iodide. However, in the case of iodine, in these same two solvents, the reverse is true. That is, iodine shows a much higher con-

ductance at the same dilution in acetone, than in epichlorhydrin. Therefore, while in the case of one of these substances it can be said with Walden, that the greater the dielectric constant of the solvent the greater the "dissociative power," in the case of the other it cannot. It cannot be held, therefore, as an infallible rule that the "dissociative power" of a solvent stands in direct parallelism to the dielectric constant.

This investigation was carried out under the supervision of Professor Louis Kahlenberg, to whom I am under many obligations for his valuable suggestions, and I take this means of acknowledging the same.

*Chemical Laboratory  
University of Wisconsin  
Madison*

## NEW BOOKS

*Handbuch der Spectroscopie. By H. Kayser. Vol. VI. 17 × 24 cm; pp. vi + 1056. Leipzig: S. Hirzel, 1912. Price: 60 marks.*—In the fifth and sixth volumes the author gives the data as to the spectra of the elements, the elements being arranged according to the alphabetical order of their symbols. The fifth volume contained the elements from argon to nitrogen; the remainder are in the sixth volume. Among the especially interesting ones are sodium, oxygen, phosphorus, sulphur, silicon, tin, strontium, titanium, and zinc. As in the preceding volume, the literature references are remarkably full. These two volumes should serve admirably as a starting point. Kayser is strongly on the side of the physicists and he does not sympathize at all with the views of Pringsheim, Smithells, and others that spectra are due to chemical reactions. There is a herculean task before the man, or group of men, who will work out the data so that these two volumes can be rewritten from the other point of view. The work of these men will be made possible by the fact that Kayser has cleared the ground for them and has collected the material so that it can now be gone over with the minimum of labor.

There is something pathetic about the preface. Kayser says that it will now be impossible for him to do more than revise these six volumes and that he will have to leave to others the writing of the volume on the astrophysical applications—the one in which he himself is most interested. No man who thinks in a big way ever finishes the work which he plans to do and Kayser is no exception to the rule. Any man, who can do for any branch of science what Kayser has done for his specialty, need not fear the verdict of his fellow men, no matter how far short of realizing his dreams he may have fallen. *Wilder D. Bancroft*

*The Measurement of High Temperatures. By G. K. Burgess and H. Le Chatelier. 3rd Ed. 15 × 22 cm; pp. xviii + 510. New York: John Wiley & Sons. Price: \$4.00 net.*—The French edition of this useful book was reviewed (4, 394). The English translation made by Burgess was reviewed (5, 660) and the second edition of this was reviewed (9, 156).

The present edition is a very welcome one, for, as is stated by M. Le Chatelier in the preface, "Mr. Burgess has rewritten anew the whole book, so that it is no longer a translation but an original work which we present to the reader."

Further, M. Le Chatelier states that, "for several years past, my studies have taken me into other fields of investigation and I have been unable to follow the considerable progress realized in the measurements of temperatures. Mr. Burgess, on the contrary, has been actively interested in these new researches, and to him is due an important part in the more recent edition."

It is certainly gratifying to the reviewer to note that Mr. Burgess has taken up the matter of high temperature measurements from this standpoint, and has given us a book which contains such a large amount of important material, material which can be obtained only through experience or personal communications with companies making high temperature measurements a specialty. The recent additions and advances in pyrometry have been given proper notice

in the present volume. The chapters on thermoelectric and electric resistance pyrometry have been increased in length in keeping with the important additions along those lines, in later years. Especially is this true in the case of the important base metal couples, which of course are used in large numbers at the present time.

The figures, and the bibliography at the end of the book, are worthy of note. The number of figures has been increased over two-fold, while their character has been maintained of the highest grade, the majority of these being line cuts.

On the other hand, however, the fact that many of the drawings are still not described—a great many of them not being lettered—detracts somewhat from the value of the work. Some of the vague statements in the second edition have not been removed.

The book, however, is an enormous improvement over the second edition, is printed on better paper, with wide margins, and contains almost twice as much material. It is certain, therefore, to be received with welcome, by students, and investigators, as well as by practical men. *C. W. Bennett*

*Lehrbuch der Thermochemie und Thermodynamik.* By *Otto Sackur*. 16 × 24 cm; Berlin: Julius Springer, 1912. Price: paper, 12 marks; bound, 13 marks.—In the preface the author says:

"It is generally recognized that a complete understanding of all the physical chemical disciplines with their scientific and technical triumphs, is only to be obtained through thermodynamics. Consequently all chemists and physicists, who wish to take part in the development of physical chemistry, must master the fundamental principles of thermodynamics and must have practice in the application of these to special problems. This text-book is written for those who wish to acquire the necessary knowledge; it also aims to give an outline of what has been accomplished."

The headings of the chapters are: introduction; the behavior of substances when heated; the equivalence of heat and work; applications of the first law of thermodynamics; the second law of thermodynamics; general conclusions from the two laws of thermodynamics; theory of solutions; the law of chemical equilibrium; thermodynamics and electrochemistry; thermoelectric phenomena; thermodynamics and capillarity; heat radiation; Nernst's heat theorem. The phase rule and the theorem of Le Chatelier come in as sections in the chapter on general conclusions from the two laws of thermodynamics.

*Wilder D. Bancroft*

*The Elements of Qualitative Chemical Analysis.* By *Julius Stieglitz*. Vol. II. 14 × 22 cm; pp. viii + 148. New York: The Century Co., 1911. Price: \$1.20.—The first volume has already been reviewed (16, 705). This present volume contains Parts III and IV. "The Laboratory Manual proper includes, as Part III of the author's book, a laboratory study of the analytical reactions of the common metal and acid ions and of the analysis of the various groups of these ions, as an introduction to the study and practice of systematic analysis. The laboratory work of this part (III) should be accompanied by classroom work on Part II of the first volume. The outline of systematic qualitative chemical analysis adopted forms Part IV of the book, and comprises the

second half of the laboratory work provided for in this manual" Part III is study of reactions while Part IV is systematic analysis. Part III is subdivided into reactions of the metal ions and reactions of the acid ions. In Part IV the subheads are: preliminary examinations; the solution of substances for the systematic analysis for metal ions; the analysis for metal ions of substances soluble in water, hydrochloric acid, nitric acid, or aqua regia; the analyses for the acid ions of substances soluble in water, acids, or aqua regia; the analysis of substances insoluble in water, acids, and aqua regia; the analysis of silicates.

Besides the regular information in the text there is much to be learned from the footnotes, on p. 15, for instance. "Barium chloride gives a more characteristic line spectrum if a loopful of ammonium chloride is held in the flame under the barium salt; the hydrochloric acid, formed by the decomposition of the ammonium chloride, reduces the amount of decomposition of the barium chloride in the flame."

Wilder D. Bancroft

*Elektrische Doppelbrechung der Kohlenstoffverbindungen.* By Richard Leiser. 25 X 17 cm.; pp. 70. Halle: Wilhelm Knapp, 1910.—The author has used a modification of the Des Coudres method and has determined the double refraction produced by an electrical field in the case of about one hundred and fifty organic liquids. The value of Kerr's constant varies very much with the constitution as well as with the composition, the value for *o*-chlortoluene, for instance, being little more than one-third that for *p*-chlortoluene. As is the case with most constitutive properties, the empirical relations are qualitative.

Wilder D. Bancroft

*Elementary Chemical Theory and Calculations.* By Joseph Knox. 12 X 19 cm.; pp. vii + 102. London: Gurney and Jackson, 1912. Price: 2 shillings.—"In this little volume an attempt has been made to give not only a series of problems in chemical arithmetic, suitable for elementary students, but also a simple, clear, and connected account of the fundamental principles on which the problems are based. The book is intended to be used with a text-book of systematic chemistry. In the theoretical part, therefore, the fundamental laws of chemistry have been discussed in their simplest form only; exceptions and limitations have been omitted. On the other hand, these laws have been discussed in a more detailed manner than is usual, but, at the same time, as simply and clearly as possible. By this means, and by the aid of numerous illustrative examples and frequent repetitions, it is hoped that many of the difficulties which this part of the subject presents to the average student may be to a certain extent overcome. The discussion of the laws of combination is followed by a short account of the atomic and molecular hypotheses, and the methods of determining molecular and atomic weights are then considered in detail.

"The theoretical matter usually included in an elementary course is thus fairly completely covered, and it is believed that the plan of presenting the theory along with the problems in this manner will be found to possess many advantages. Throughout the book the standard  $O = 16$  has been adopted as the basis of atomic weights. The answers to the calculations have been obtained by the use of four-figure logarithms, and for this reason the atomic weight of hydrogen has been taken throughout as 1.01 instead of the more exact value 1.008 [0.0043

buffers from 0.0035 even in four-place logarithms). In all other cases, except where especially mentioned, the international atomic weights (1912) have been used in the calculations, since it is as easy to work with exact atomic weights as with approximate ones, and more instructive. The student is strongly advised to provide himself with a table of four-figure logarithms, and to master the use of them for the operations of multiplication and division—a task which he would accomplish in an hour at most."

The problems are grouped under the following headings: the metric system; thermometric scales; influence of temperature and pressure on the volume of gases; percentage composition; laws of chemical composition; equivalents; atomic and molecular hypotheses; outline of general method for determinations of atomic weights; determination of molecular weights by vapor density methods; freezing-point and boiling-point methods; determination of atomic weight from specific heat; deduction of formula from percentage composition; percentage composition from formula; calculation of reacting quantities by weight and volume from chemical equations; diffusion of gases.

*Wilder D. Bancroft*

**A Laboratory Manual of Inorganic Chemistry.** By John B. Ekeley. 13 × 19 cm; pp. viii + 128. New York: John Wiley & Sons, 1912. Price, \$1.00.—"The author has used Professor Holleman's 'Text-Book of Inorganic Chemistry' in his classes for a number of years, and each year the merit of this splendid text becomes more apparent. To meet a demand in his own classes for a laboratory manual written and arranged for use in connection with Professor Holleman's text, he has gathered together the set of experiments here published. He has found them to work well in his own laboratory, and hopes that they will prove a help to others in the teaching of beginners in chemistry."

*Wilder D. Bancroft*

**A Text-Book of Physics.** By A. Wilmer Duff. 3rd Ed. 13 × 20 cm; pp. xiii + 686. Philadelphia: P. Blakiston's Son & Co., 1912.—"This excellent college text, as the editor remarks in the preface to the first edition, is the result of the attempt of six experienced college teachers to compile a work more satisfactory in every branch than any existing one. In this undertaking they have been very successful. The important topics treated in large type are, in this edition, all consecutive and may be used independently as a shorter course. The subject matter is fully but tersely expressed and in most cases deals with the mathematical as well as the physical definitions. Entirely new parts have been prepared on the subject of heat, Electricity and Magnetism, and the work is profusely illustrated with halftones, drawings, diagrams and curves of more than ordinary merit.

The editor states in the preface to this edition: "The great importance which the electron theory has assumed since the appearance of the first edition has led to its introduction at various points, but, inasmuch as the details of this theory are still somewhat speculative, it has usually been treated in fine print and can be omitted at the discretion of teachers who use the book in their classes. To facilitate reference, a list of tables of constants has been given and the indexes have been somewhat increased."

*Charles O. Brown*



THE RELATION OF THE VALUE "a" OF VAN DER  
WAALS' EQUATION TO THE MOLECULAR  
WEIGHT AND THE NUMBER OF  
VALENCES OF THE  
MOLECULE

BY ALBERT P. MATHEWS

The discovery of the properties of the molecule upon which cohesion depends is a matter of great interest. I have found that "a" of van der Waals' equation is equal to a constant multiplied into the square of the cube root of the product of the molecular weight by the number of valences in the molecule. This enables a calculation of the valence number of a molecule from the critical constants; and on the other hand a calculation of "a" from the valence and molecular weight. Some interesting facts have been discovered relative to the valence of the halogens, of the argon group and some other elements by the application of this rule.

If the value  $a/V^2$  of van der Waals' equation, which represents the internal, or cohesive, pressure per unit surface, be divided in both the numerator and denominator by  $N^2$ ,  $N$  being the number of molecules in the volume  $V$ , we obtain a value for "a" which may be called the molecular cohesive pressure and which is independent of the volume. If "a" be represented by the expression  $N^2M^2K$ , in which  $M$  is the mass of cohesion of a molecule and  $K$  a constant, then since  $V^2$  is equal to  $N^2v^2$ ,  $v$  being the volume at the disposal of a single molecule,  $a/V^2 = N^2M^2K/N^2v^2 = M^2K/v^2$ . This value  $M^2K$  may be computed from "a" by dividing the latter by  $N^2$ .  $N$ , the number of molecules in a cc. of gas under standard conditions, is equal to  $2.77 \times 10^{19}$ . In the computations which follow I have taken the value of "a" in dynes instead of atmospheres and wherever possible I have used the value of  $M^2K$  computed by the surface tension formula described in a previous paper.<sup>1</sup>

<sup>1</sup> Mathews: Jour. Phys. Chem., 17, 154 (1913).

Tables I and II bring out the relationship that  $M$  is some function of the molecular weight and the number of valences in the molecule, or  $M^2K = f(\text{Wt})(\text{Valence})$ . The relationship to molecular weight appears if we compare compounds of the same valence number as shown in Table I.

TABLE I

Substance	Mol. weight	Valences	$M^2K \times 10^{28}$
$\text{CO}_2$	44.0	8	1.216
$\text{CCl}_4$	153.8	8 <sup>1</sup>	5.526
$\text{GeCl}_4$	214.3	8	6.274
$\text{SnCl}_4$	260.8	8	7.499
$\text{C}_6\text{H}_6$	78.0	30	5.181
$\text{C}_6\text{H}_5\text{F}$	96.0	30	5.465
$\text{C}_6\text{H}_5\text{Cl}$	112.45	30	7.017
$\text{C}_6\text{H}_5\text{Br}$	157.0	30	7.810(?)
$\text{C}_6\text{H}_5\text{I}$	204.0	30	9.135(?)
Ether	74.0	28	4.797
Methyl propionate	88.0	28	5.377
Ethyl acetate	88.0	28	5.397

It is clear from Table I that the factor  $M^2K$  increases steadily with the molecular weight.

The importance of valence is shown in Table II. A heavier compound, if it have fewer valences, may have a lower mass of cohesion than a lighter substance.

TABLE II

Substance	Mol. weight	Valences	$M^2K \times 10^{28}$
$\text{C}_6\text{H}_5\text{I}$	204.0	30	9.135
$\text{SnCl}_4$	260.8	8	7.499
$\text{C}_6\text{H}_5\text{Br}$	157.0	30	7.810
$\text{CCl}_4$	153.8	8	5.526
Iso-pentane	72.0	32	5.089
Ether	74.0	28	4.797
Ethyl formate	74.0	22	4.188

<sup>1</sup> The valence of the halogens in this and the next table is, for simplicity, taken as unity. Their true valence is discussed farther on.

It might also be imagined that the mass of cohesion was a function of the number of atoms in the molecule, rather than the number of valences, but a trial of this possibility showed that this was not the case.

After many trials in which the mass of cohesion, or the factor  $M^2K$ , was supposed to be a function of the first power, the square, the square root, or the square of the cube root of the product of the number of valences and the molecular weight, it was found that only the last supposition yielded a consistent result. In all the other guesses, the proportionality factor "C" was far from being constant. Hence we have:  $M^2K = C(\text{Wt} \times \text{Val.})^{2/3}$ .

With the values of  $M^2K$  computed by the surface tension formula it was found that the quotient  $M^2K/(\text{Wt.} \times \text{Val.})^{2/3}$  was indeed as constant as could be expected and C had a mean value of  $2.98 \times 10^{-37}$ , when  $M^2K$  is the square of the mass of cohesion of one molecule multiplied by K and expressed in absolute units. If "a" of van der Waals' equation is taken for 1 cc. of gas under standard conditions and expressed in atmospheres, the proportionality factor C would be  $2.2564 \times 10^{-4}$ . This gives values for "a" a little higher than those generally accepted owing to my having used the coefficient 2.19 instead of 2.12 in computing  $M^2K$  from the surface tension. The computation of "a" for ether by the formula  $2.2564 \times 10^{-4} (\text{Weight} \times \text{Valences})^{2/3}$  gives the value 0.03669, whereas the value from the usual formula of van der Waals is 0.03473; the coefficient 2.12 would have given the value 0.03550. The fact that these values are throughout proportionally somewhat higher than those usually assumed does not affect the constancy of C.

Table III shows that the quotient  $M^2K/(\text{Wt. Val.})^{2/3}$  really equals a constant when  $M^2K$  is computed for the compounds of carbon, hydrogen and oxygen of which the critical data have been so carefully determined by Young. For the elements of these compounds there is no doubt of the valence number. Carbon is always quadrivalent, hydrogen univalent; and oxygen has been taken as bivalent.

TABLE III  
 $C = M^2K / (Wt. Val.)^{1/2}$ 

Substance	Formula	Log <sub>10</sub> M <sup>2</sup> K	Mol. wt.	No. of valences	C × 10 <sup>27</sup>	Remarks
1 Pentane	C <sub>5</sub> H <sub>12</sub>	-35.71925	72	32	3.00	
2 Isopentane	C <sub>5</sub> H <sub>12</sub>	-35.70663	72	32	2.92	
3 Ether	C <sub>4</sub> H <sub>10</sub> O	-35.68097	74	28	2.95	
4 Et formate	C <sub>3</sub> H <sub>6</sub> O <sub>2</sub>	-35.62201	74	22	3.03	
5 Me acetate	C <sub>3</sub> H <sub>6</sub> O <sub>2</sub>	-35.61794	74	22	3.00	
6 Me formate	C <sub>2</sub> H <sub>4</sub> O <sub>2</sub>	-35.47611	60	16	3.08	
7 Benzene	C <sub>6</sub> H <sub>6</sub>	-35.71441	78	30	2.94	
8 Hexamethylene	C <sub>6</sub> H <sub>12</sub>	-35.78661	84	36	2.93	
9 Diisopropyl	C <sub>6</sub> H <sub>14</sub>	-35.80760	86	38	2.92	
10 Hexane	C <sub>6</sub> H <sub>14</sub>	-35.82633	86	38	3.04	
11 Et acetate	C <sub>4</sub> H <sub>8</sub> O <sub>2</sub>	-35.73215	88	28	2.96	
12 Prop formate	C <sub>3</sub> H <sub>6</sub> O <sub>2</sub>	-35.74039	88	28	3.01	
13 Me propionate	C <sub>4</sub> H <sub>8</sub> O <sub>2</sub>	-35.73954	88	28	2.95	
14 Fluorbenzene	C <sub>6</sub> H <sub>5</sub> Fl	-35.75295	96	30	2.80	Fl = 1; V <sub>c</sub> /V <sub>o</sub> = 3.86
15 Heptane	C <sub>7</sub> H <sub>16</sub>	-35.91924	100	44	3.09	
16 Me butyrate	C <sub>6</sub> H <sub>10</sub> O <sub>2</sub>	-35.83149	102	34	2.96	
17 Me isobutyrate	C <sub>6</sub> H <sub>10</sub> O <sub>2</sub>	-35.81895	102	34	2.88	
18 Chlorbenzene	C <sub>6</sub> H <sub>5</sub> Cl	-35.84615	112.45	32	2.99	Cl = 3
19 Octane	C <sub>8</sub> H <sub>18</sub>	-34.00100	114	50	3.15	
20 Diisobutyl	C <sub>8</sub> H <sub>18</sub>	-35.97959	114	50	2.99	
21 Prop acetate	C <sub>5</sub> H <sub>10</sub> O <sub>2</sub>	-35.83398	102	34	2.98	
22 Et propionate	C <sub>5</sub> H <sub>10</sub> O <sub>2</sub>	-35.83072	102	34	2.96	
23 Brombenzene	C <sub>6</sub> H <sub>5</sub> Br	-35.89265	157	30	2.78	T <sub>c</sub> and V <sub>c</sub> estimated
24 Iodobenzene	C <sub>6</sub> H <sub>5</sub> I	-35.90071	204	30	2.73	T <sub>c</sub> and V <sub>c</sub> estimated
25 Carbon tetrachloride	CCl <sub>4</sub>	-35.74247	153.8	16	3.03	Cl = 3
26 Stannic chloride	SnCl <sub>4</sub>	-35.87500	260.8	16	2.89	Cl = 3

 Mean (omitting C<sub>6</sub>H<sub>5</sub>I and C<sub>6</sub>H<sub>5</sub>Br), 2.98

It will be seen in Table III that  $C$  has a mean value of  $2.98 \times 10^{-37}$  for the twenty-six non-associating, or nearly non-associating, substances studied by Young. The greatest deviation from the mean is octane on the one side, which deviates a little more than four percent; and on the other, fluorobenzene, which deviates 6 percent, methyl isobutyrate deviating a little over 3 percent, and brom- and iodobenzene. The deviation of the last two substances, about 7 percent, may, I think, be disregarded since the critical temperature and pressure were estimated and not directly determined; the critical data are therefore less certain. The other twenty-one substances do not deviate more than 3 percent from the mean. The cause of the deviation of fluorobenzene is uncertain, but there is a regularity in the other deviations which suggests that the size, shape, or compressibility of the molecule may play a slight rôle in determining the critical data, or the coefficients of our formulas. For it appears that  $M^2K$ , and hence  $C$ , is always lower in the iso-compounds than in the corresponding normal compounds. Diisobutyl has  $C$  of the mean value, whereas normal octane has a high value for  $C$ ; a similar relationship exists between diisopropyl and hexane; and between iso- and normal pentane. Some of this difference would disappear if, instead of taking  $v_0$  equal to  $v_c/4$ , I had used the accurate ratio computed from the law of rectilinear diameter. Thus  $V_0$  of isopentane is only  $V_c/3.92$ ; while that of pentane is  $V_c/3.96$  and octane is  $V_c/4.04$ . The substitution of these values for  $V_0$  in computing  $M^2K$  would have made  $C$  of isopentane 2.98; of pentane, 3.03. The difference is not entirely due then to this factor. It seems more probable to me that  $b_c$  is not always exactly the same fraction of  $V_c$  and that consequently the coefficients of the formulas used in computing  $M^2K$  are not exactly the same in all substances.

Notwithstanding these slight deviations, the constancy of  $C$  is certainly remarkably good and shows beyond question, I think, that a close connection exists between molecular cohesion and the molecular weight and number of valences in the molecule.

TABLE IV

Substance	Formula	Log <sub>10</sub> M <sup>2</sup> K	Mol. wt.	No. of valences	C × 10 <sup>21</sup>	Critical data used in computing M <sup>2</sup> K
1 Ethylene	C <sub>2</sub> H <sub>4</sub>	-35.15671 <sup>1</sup>	28	12	2.97	d <sub>c</sub> = 0.21; T <sub>c</sub> = 10; P <sub>c</sub> = 51.7
2 Toluene	C <sub>7</sub> H <sub>8</sub>	-35.82459	92	36	3.01	T <sub>c</sub> = 320.6; P <sub>c</sub> = 41.6
3 Cymol	C <sub>10</sub> H <sub>14</sub>	-34.06800	134	54	3.13	T <sub>c</sub> = 378.6; P <sub>c</sub> = 28.6
4 Decane	C <sub>10</sub> H <sub>22</sub>	-34.12922	142	62	3.16	T <sub>c</sub> = 330.4; P <sub>c</sub> = 21.3
5 Diethylamine	C <sub>4</sub> H <sub>11</sub> N	-35.68002	73	30	2.84	T <sub>c</sub> = 222; P <sub>c</sub> = 40
6 Dimethylamine	C <sub>3</sub> H <sub>7</sub> N	-35.42717	45	18	3.08	T <sub>c</sub> = 163; P <sub>c</sub> = 56
7 Ethane	C <sub>2</sub> H <sub>6</sub>	-35.21866	30	14	2.95	T <sub>c</sub> = 35; P <sub>c</sub> = 45.2
8 Acetylene	C <sub>2</sub> H <sub>2</sub>	-35.08564	26	10	2.99	T <sub>c</sub> = 35.5; P <sub>c</sub> = 61.6
9 Propane	C <sub>3</sub> H <sub>8</sub>	-35.39037	44	20	2.68	T <sub>c</sub> = 97; P <sub>c</sub> = 44
10 Propyl amine	C <sub>3</sub> H <sub>9</sub> N	-35.58048	59	24	3.02	T <sub>c</sub> = 218; P <sub>c</sub> = 50
11 Propyl benzol	C <sub>9</sub> H <sub>12</sub>	-35.99865	120.0	48	3.10	T <sub>c</sub> = 365.6; P <sub>c</sub> = 32.3
12 Propyl chloride	C <sub>3</sub> H <sub>7</sub> Cl	-35.59465	78.45	20	2.91	T <sub>c</sub> = 221; P <sub>c</sub> = 49; Cl = 1
13 Pseudo-cumol	C <sub>9</sub> H <sub>12</sub>	-34.00767	120	48	3.17	T <sub>c</sub> = 381.2; P <sub>c</sub> = 33.2
14 Me valerate	C <sub>8</sub> H <sub>12</sub> O <sub>2</sub>	-35.92785	116	40	3.05	T <sub>c</sub> = 293.7; P <sub>c</sub> = 31.5; d <sub>c</sub> = 0.279
15 Phenetol	C <sub>8</sub> H <sub>10</sub> O	-35.97509	122	44	3.08	T <sub>c</sub> = 374; P <sub>c</sub> = 33.8
16 Chloroform	CHCl <sub>3</sub>	-35.61128	119.35	14	2.90	T <sub>c</sub> = 260; P <sub>c</sub> = 54.9; Cl = 3
17 Me chloride	CH <sub>3</sub> Cl	-35.26811	50.45	10	2.93	T <sub>c</sub> = 141.5; P <sub>c</sub> = 73; Cl = 3
18 Me fluoride	CH <sub>3</sub> F	-35.10958	34	8	3.07	T <sub>c</sub> = 44.9; P <sub>c</sub> = 62; Fl = 1
19 Isoamylene	C <sub>6</sub> H <sub>10</sub>	-35.69737	70	30	3.04	T <sub>c</sub> = 191.6; P <sub>c</sub> = 33.9
20 Isobutyl benzene	C <sub>10</sub> H <sub>14</sub>	-34.03059	134	54	2.87	T <sub>c</sub> = 377.1; P <sub>c</sub> = 31.1
21 Isopropyl benzene	C <sub>9</sub> H <sub>12</sub>	-35.99603	120	48	3.08	T <sub>c</sub> = 362.5; P <sub>c</sub> = 32.2

<sup>1</sup> This is a mean value of M<sup>2</sup>K computed by the several different formulas given in my previous paper.

TABLE IV (Continued)

22	Methyl ether	$C_2H_6O$	—35.35126	46	16	2.76	$T_c = 129.6; P_c = 57$
23	Methyl ethyl ether	$C_3H_8O$	—35.52175	60	22	2.76	$T_c = 168.4; P_c = 46.3;$ $d_c = 0.307$
24	Dimethyl-o-toluidine	$C_9H_{12}N$	—34.03389	135	52	2.95	Guye and Mallet "a"
25	Dipropyl amine	$C_9H_{15}N$	—35.88675	101	42	2.94	$T_c = 277; P_c = 31$
26	Germanium tetrachloride	$GeCl_4$	—35.79817	214.3	16	2.76	$T_c = 276.9; P_c = 38; Cl = 3$
27	Anisol	$C_7H_8O$	—35.87207	108	38	2.91	Guye and Mallet "a"
28	Ethyl butyrate	$C_8H_{16}O_2$	—35.88584	108	40	2.90	$T_c = 292.8; P_c = 30.24$
29	Ethyl chloride	$C_2H_5Cl$	—35.49356	64.45	16	3.05	$T_c = 182.6; P_c = 52.6;$ $Cl = 3$
30	Ethylidene chloride	$C_2H_4Cl_2$	—35.63725	98.9	18	2.95	$T_c = 250; P_c = 50; Cl = 3$
31	Xylol	$C_8H_{10}$	—35.93390	106	42	3.17	$T_c = 344; P_c = 35$
32	Triethylamine	$C_6H_{15}N$	—35.87209	101	42	2.84	$T_c = 259; P_c = 30$
33	Trimethylamine	$C_3H_9N$	—35.55859	59	24	2.87	$T_c = 160.5; P_c = 41$
34	Carbon bisulphide	$CS_2$	—35.53733	76	16	3.03	$T_c = 273; P_c = 73; S = 6;$ $V_c = 175.6$
35	Isobutyl acetate	$C_8H_{16}O_2$	—35.91209	116	49	2.94	$T_c = 295.8; P_c = 31.4$
36	Diphenyl	$C_{12}H_{10}$	—34.14224	154	58	3.22	$T_c = 495.6; P_c = 31.8$
37	Diphenyl methane	$C_{12}H_{12}$	—34.18482	166	64	3.17	$T_c = 497; P_c = 28.2$
38	Durene	$C_{10}H_{14}$	—34.07619	134	54	3.19	$T_c = 402.5; P_c = 28.6$
39	Mesitylene	$C_9H_{12}$	—35.96426	120	48	2.87	$T_c = 367.6; P_c = 33.2$
40	Ethyl benzol	$C_8H_{10}$	—35.90224	106	42	2.95	$T_c = 346.4; P_c = 38.1$
41	Isobutyl formate	$C_6H_{12}O_2$	—35.84701	102	34	3.07	$T_c = 278.2; P_c = 38.3;$ $d_c = 0.2879$

Mean value of C 2.98

Table IV is a summary of the values of  $C$  computed for forty-one other substances, of many of which the critical data are not so accurately known as those included in Table III. Since for most of these substances  $d_c$  and  $V_c$  were not given in the Landolt-Börnstein-Meyerhoffer tables, I computed  $V_c$  by the formula  $V_c P_c / T_c = 21.92$  and then  $M^2K$  by the formula  $M^2K = 3.594 \times 10^{-10} V_c T_c$ . The values of  $V_c$  so computed are of course not so accurate. Wherever the critical volume or density was given it was used. In a few cases, which are specified,  $M^2K$  was obtained by dividing the value of " $a$ ," given by Guye and Mallet, by  $N^2$ , *i. e.*,  $(2.77 \times 10^{10})^2$ .

While the values are thus less certain and the deviations somewhat greater, the mean value of all is what it was for the other substances, *i. e.*,  $C = 2.98 \times 10^{-37}$ . The values are surprisingly uniform. It will be noticed that the more complex substances such as diphenyl and diphenyl methane have  $C$  a little high. This may possibly be due to slight association or quasi-association in these substances. With this and one or two other exceptions the uniformity of  $C$  is marked.

All substances known to be associating give a value for  $C$  higher than  $2.98 \times 10^{-37}$  when  $M^2K$  is computed by the same formulas as for normal substances, and the weight and valence used in computing  $C$  are those of the normal non-associated molecule. This result is to be anticipated, since in these substances the molecular weight and valence do not remain the same throughout the temperature interval. The computation of  $M^2K$  from the critical data is uncertain in the case of associating substances for the reason that there is no certainty that the coefficients of the formulas are the same for these substances as for normal substances. Although the figures for  $M^2K$  are thus uncertain, I have nevertheless calculated  $M^2K$  by the usual formula in order to show that these substances deviate in the direction we should expect from the value of  $C$  found in normal substances. The results are given in Table V:



## Value of "a" of van der Waals' Equation

TABLE V

Substance	Formula	Log <sub>10</sub> M <sup>2</sup> K	Normal weight	No. of valences	C × 10 <sup>3</sup>	Remarks
1 Propyl alcohol	C <sub>3</sub> H <sub>8</sub> O	—35.62672	60	22	3.52	M <sup>2</sup> K = V <sub>c</sub> T <sub>c</sub> 3.594 × 10 <sup>-10</sup>
2 Methyl alcohol	CH <sub>4</sub> O	—35.33602	32	10	4.63	M <sup>2</sup> K = V <sub>c</sub> T <sub>c</sub> 3.594 × 10 <sup>-10</sup>
3 Ethyl alcohol	C <sub>2</sub> H <sub>6</sub> O	—35.56793	46	16	4.54	M <sup>2</sup> K = V <sub>c</sub> T <sub>c</sub> 3.594 × 10 <sup>-10</sup>
4 Acetic acid	C <sub>2</sub> H <sub>4</sub> O <sub>2</sub>	—35.56329	60	16	3.76	M <sup>2</sup> K = V <sub>c</sub> T <sub>c</sub> 3.594 × 10 <sup>-10</sup>
5 Propionitrile	C <sub>3</sub> H <sub>5</sub> N	—35.77583	55	20	5.60	M <sup>2</sup> K = T <sub>c</sub> <sup>2</sup> (3.057 × 10 <sup>9</sup> )/PN <sup>2</sup>
6 Benzonitrile	C <sub>6</sub> H <sub>5</sub> N	—35.96933	103	36	3.87	M <sup>2</sup> K = T <sub>c</sub> <sup>2</sup> (3.057 × 10 <sup>9</sup> )/PN <sup>2</sup>
7 Capronitrile	C <sub>6</sub> H <sub>11</sub> N	—35.97752	97	38	3.98	M <sup>2</sup> K = T <sub>c</sub> <sup>2</sup> (3.057 × 10 <sup>9</sup> )/PN <sup>2</sup>
8 Butyronitrile	C <sub>4</sub> H <sub>7</sub> N	—35.85452	69	26	4.85	M <sup>2</sup> K = T <sub>c</sub> <sup>2</sup> (3.057 × 10 <sup>9</sup> )/PN <sup>2</sup>
9 Ammonia	NH <sub>3</sub>	—35.04731	17	6	5.11	T <sub>c</sub> = 130; P <sub>c</sub> = 115
10 Hydrogen sulphide	H <sub>2</sub> S	—35.08657	34	4	4.64	T <sub>c</sub> = 100; P <sub>c</sub> = 90
11 Methyl amine	CH <sub>5</sub> N	—35.30293	31	12	3.88	T <sub>c</sub> = 155; P <sub>c</sub> = 72
12 Phosphoretted hydrogen	PH <sub>3</sub>	—35.11711	34	6	3.78	T <sub>c</sub> = 52.8; P <sub>c</sub> = 64
13 Meta cresol	C <sub>7</sub> H <sub>8</sub> O	—35.94056	108	38	3.40	T <sub>c</sub> = 432; P <sub>c</sub> = 45
14 Aniline	C <sub>6</sub> H <sub>7</sub> N	—35.86700	93	34	3.42	T <sub>c</sub> = 425.7; P <sub>c</sub> = 52.35
15 Thiophene	C <sub>4</sub> H <sub>4</sub> S	—35.76101	84	22	3.83	T <sub>c</sub> = 317.3; P <sub>c</sub> = 47.7

I have also calculated the value of  $M^2K$  and the quotient  $C$  of a number of other substances from the surface tension measurements of Ramsay and Shields. From the surface tension, the critical temperature may be calculated approximately by the rule of Eötvös, revised by Ramsay and Shields, namely,  $K(T_c - T - 6) = S(Mv)^{2/3}$ , where  $S$  is the surface tension in dynes at the absolute temperature  $T$  and  $Mv$  the molecular volume. Having thus found  $T_c$ , the fraction  $T/T_c$  may be calculated for any temperature and by interpolation from the curve expressing the relation between  $T/T_c$  and  $V/V_c$ ,  $V/V_c$  may be found and from this  $V_c$  may be calculated if  $V$  is known. We thus obtain the theoretical critical volume. From  $V_c$  and  $T_c$  the value of  $M^2K$  may be calculated either by the surface tension formula or the formula  $M^2K = V_c T_c 3.594 \times 10^{-10}$ . I shall, in the first place, show how exactly the law correlating  $M^2K$  with weight and valence holds for some substances which do not contain chlorine but contain elements of which the valence is fairly certain. Some of these substances associate slightly. The results are summarized in Table VII.

From Table VI it may be seen that the values obtained for  $C$ , although less reliable than those from the other tables, nevertheless agree well with the mean of about  $3 \times 10^{-37}$ .

The substances marked associating in the above table were found to be so by Dutoit and Mojoïu,<sup>1</sup> who determined the association and calculated the mean molecular weight at various temperatures.

There are two sources of uncertainty in computing " $a$ " and  $M^2K$  for the simplest gases; the first is the uncertainty of the critical data of some of them; and the second, the uncertainty that the coefficients of the formulas hitherto used for calculating these values remain the same for the gases. If the usual formula for " $a$ " be used, by which " $a$ " is calculated from the pressure and temperature, the formula being derived from certain assumptions as to the value of the crit-

<sup>1</sup> Dutoit and Mojoïu: Constante de capillarité et poids moléculaire. Jour. Chim. Phys., 7, 169 (1909).

TABLE VI

Substance	Formula	Calc. $T_c$ , Abs.	Calc. $V_c$	Log <sub>10</sub> $M^2K$	Mol. wt.	No. of valences	No. of $C \times 10^{10}$	Remarks
1 Pyridine	$C_5H_5N$	617.2	240	-35.72618	79	28	3.14	Associates
2 Aniline	$C_6H_7N$	677.9	279.6	-35.83315	93	34	3.16	"
3 Nitrobenzene	$C_6H_5NO_2$	715.4	323.5	-35.92012	123	36	3.08	"
4 Benzotrile	$C_6H_5CN$	671	313	-35.87843	103	36	3.16	"
5 Quinoline	$C_8H_7N$	739.1	370	-35.99255	129	46	3.00	Normal
6 Quaiacol	$C_7H_7O$	699.8	342	-35.93470	124	40	2.96	"
7 Paraldehyde	$C_3H_2O_2$	583.5	394	-35.91365	132	54	2.84	"
8 Acetic anhydride	$C_4H_6O_3$	608.9	283	-35.79183	102	28	3.08	"
9 Piperidine	$C_4H_{10}N$	604.4	292	-35.80236	85	34	3.24	Normal
10 Me propyl ketone	$C_5H_{11}N$	604.4	$P_c = 45.9$	-35.79995	85	34	3.11	Guye and Mallet
11 Ethyl acetate	$C_4H_{10}O$	569.6	301	-35.79142	86	32	3.15	Associates
		668	389	-35.96831	130	40	3.10	

ical coefficient, the value of  $C$  is, for fairly complex substances, about  $2.80 \times 10^{-37}$ ; but in the simple gases, such as  $N_2O$ ,  $H_2$ ,  $O_2$ ,  $N_2$ , etc., it is uniformly lower and about 2.25. The question is, therefore, whether this formula does not give an exact value for  $M^2K$ , or whether the relation of  $M^2K$  to the weight and valence is only approximate and does not remain the same for the simple substances. It is possible that the ratio 27/64 in the "a" formula is not the same for all substances, but may vary a little with the complexity, or compressibility, of the molecule. To solve this uncertainty, I have computed  $M^2K$  directly from the surface tension of the liquid gases by the half empirical formula which holds pretty well for more complex substances:  $M^2K(1/v_l - 1/v_v) = 3Sv_l^{2/3} [(T_c - 6)/(T_c - T - 6)]^{2/3}$ . I have used the data of Baly and Donnan in this calculation. I also calculated  $M^2K$  from the latent heat of vaporization from figures given by Dewar in his article on Liquid Gases in the Encyclopedia Britannica, by the formula:  $L - E = a(1/V_l - 1/V_v)$ .  $a = N^2M^2K$ . This formula neglects the heat used in the expansion of the molecules in passing from the liquid to the vapor. It generally gives, therefore, a value of  $M^2K$  somewhat too high. I have also computed  $M^2K$  by the usual formulas involving  $V_c$  and  $T_c$  instead of  $P_c$  such as the surface tension formula. In Table VII I have included the values thus calculated for hydrogen, using successively the critical data of Olszewski and Dewar.

It is evident that a considerable uncertainty in the case of hydrogen arises from the uncertainty of the critical data. I think the  $P_c V_c^2$  formula gives too high results. If we take the mean of all it would be  $-37.88161$ . With the valence 2 and the weight 2 this would give for "c" a value of  $3.02 \times 10^{-37}$ , which is close to the value obtained before.

I have made similar calculations in the case of oxygen, nitrogen, carbon dioxide and nitrous oxide. For the sake of brevity I omit these and give in Table VIII only the mean value for  $M^2K$  for each gas.

It is clear from Table VIII that with the exception of car-

TABLE VII  
Values of  $M^2K$  for hydrogen

Log <sub>10</sub> $M^2K$	Formula	Critical data used	
37.82276	Latent heat		
37.95621	$M^2K = V_c^2 P_c 1.6296 \times 10^{-47}$	$T_c = 32; P_c = 15; V_c = 60.42$	Dewar
37.80014	$M^2K = 9.045 \times 10^{-16} (T_c - 6)^{7.0}$	$T_c = 32; P_c = 15; V_c = 60.42$	
37.84190	$M^2K = V_c T_c^3 3.594 \times 10^{-40}$	$T_c = 32; P_c = 15; V_c = 60.42$	
37.87758	$M^2K = V_c T_c^3 3.594 \times 10^{-40}$	$T_c = 38.5; P_c = 20; V_c = 54.52$	
37.99118	$M^2K = P_c V_c^2 1.6296 \times 10^{-47}$	$T_c = 38.5; P_c = 20; V_c = 54.52$	Olszewski
37.85242	$M^2K = 9.045 \times 10^{-16} (T_c - 6)^{7.0}$	$T_c = 38.5; P_c = 20; V_c = 54.52$	

TABLE VIII

Substance	Formula	Log <sub>10</sub> M <sup>2</sup> K	Mol. wt.	No. of valen. ccs	C × 10 <sup>21</sup>	Formula used
1 Hydrochloric acid	HCl	-36.88550	36.45	2	4.49	Associates
2 Hydrogen selenide	H <sub>2</sub> Se	-35.14572	81.2	4	2.96	V <sub>c</sub> = 94.9; T <sub>c</sub> = 138; P <sub>c</sub> = 91
3 Sulphurous anhydride	SO <sub>2</sub>	-35.27880	64	8	2.97	T <sub>c</sub> = 156; P <sub>c</sub> = 78.9; V <sub>c</sub> = 123.1
4 Nitrous oxide	N <sub>2</sub> O	-35.09684	44	6(?)	3.04	P <sub>c</sub> = 75; d <sub>c</sub> = 0.41; T <sub>c</sub> = 35.4
5 Carbon dioxide	CO <sub>2</sub>	-35.08430	44	6	2.95	Mean value of M <sup>2</sup> K
6 Oxygen	O <sub>2</sub>	-36.65703	32	2(?)	2.84	"
7 Nitrogen	N <sub>2</sub>	-36.63671	28	2	2.96	"
8 Hydrogen	H <sub>2</sub>	-37.88161	2	2	3.02	"
9 Bromine	Br <sub>2</sub>	-35.14659	159.92	2	3.00	T <sub>c</sub> = 302.2; d <sub>c</sub> = 1.18
10 Chlorine	Cl <sub>2</sub>	-35.22351	70.9	6	2.96	T <sub>c</sub> = 146; P <sub>c</sub> = 93.5; V <sub>c</sub> = 111; Cl = 3
11 Carbon monoxide	CO	-36.65853	28	4	1.96	T <sub>c</sub> = -139.5; P <sub>c</sub> = 35.5; d <sub>c</sub> = 1.14
Carbon monoxide	CO	-36.65853	28	2(?)	3.11	

bon monoxide, which is hopelessly aberrant if carbon and oxygen have a higher valence than one, the value of C comes close to the value found in other substances, namely,  $2.98 \times 10^{-37}$ . It is true that in making the calculation I have, in one or two instances, used other valence numbers than those generally attributed to the elements. Thus chlorine is trivalent. But I shall show in a subsequent paper that chlorine is always trivalent in its organic compounds; nitrogen in the gaseous form is univalent, while it is bivalent in nitrous oxide;<sup>1</sup> but both these valences have already been ascribed to nitrogen. Oxygen cannot have more than two valences in the molecule. The value I have taken for M<sup>2</sup>K is certainly as high as the facts warrant and the critical data seem reliable. I believe that the conclusion is justified that oxygen is monovalent in its gaseous form. The surprising fact is the value for carbon dioxide. The carbon cannot be more than bivalent here, giving a kind of peroxide formula, if carbon dioxide is to follow the rule. On the whole, the gases agree well with the results already obtained for C.

In a subsequent paper I shall show that all chlorine compounds also follow the rule if the chlorine be taken trivalent; and that there is good reason, from quite independent sources, to attribute a valence of three to chlorine. The valences of sulphur, nitrogen and the argon group will also be considered separately.

In closing it may be pointed out that the law just established can be used to determine the number of valences in a molecule if M<sup>2</sup>K of the substance is known, or if its critical data are known, as follows: If the computation is made from the approximate values of "a" given in the Landolt-Börnstein-Meyerhoffer tables, which were computed by the formula:  $a = 27T_c^2 / (64 \times 273^2 \times P_c)$ , proceed by the following formula: (1) Valence number =  $(a)^{3/2} \times 3.2 \times 10^6 / (\text{Mol. Wt.})$ . Or, if the calculation is made from the critical data, the following formula will serve:

<sup>1</sup> Possibly nitrogen is univalent in this gas, but the oxygen is quadrivalent, having two free valences.

- (2) Val. number =  $0.0043 T_c^3 / P_c^{3/2}$  (Mol. Wt.); or, if the calculation is made from the temperature and volume:  
 (3) Val. number =  $4.21 \times 10^{-5} \times (V_c T_c)^{3/2} / (\text{Mol. Wt.})$ .

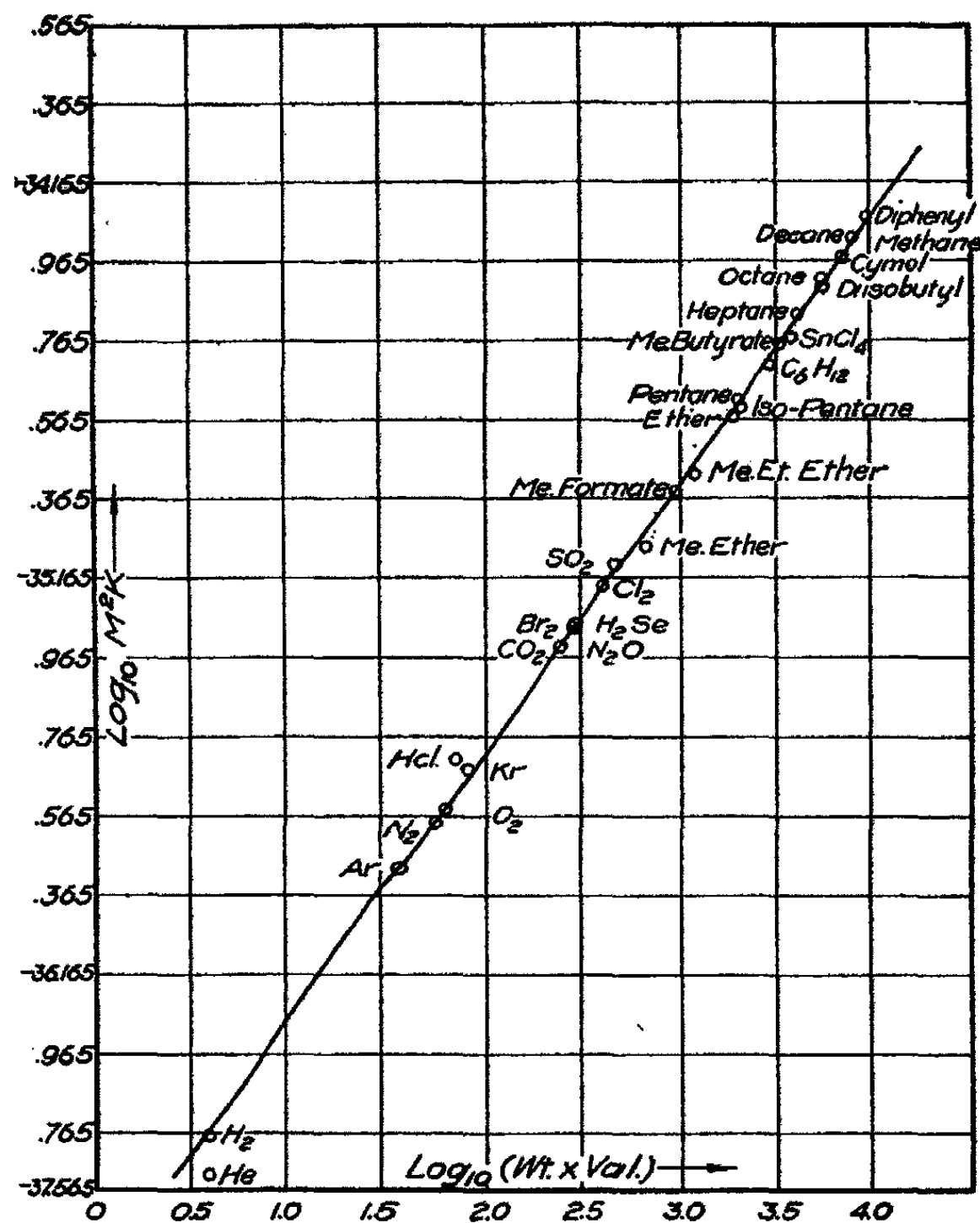

Fig. 1.—Showing the relationship between the logarithm of  $M^3K$  and the logarithm of the product of the molecular weight by the number of valences

In these formulas  $V_c$  is the critical volume of a gram mol. in cubic centimeters;  $T_c$ , the absolute critical temperature; and  $P_c$  the critical pressure in atmospheres.



How accurately the number of valences can be calculated by the first formula is shown by Table IX, which is, of course, little more than a rearrangement of the results already stated in the preceding tables, except that in this instance I have used the approximate values of "a" given in the Landolt tables computed by the formula  $a = 27T_c^2/(64 \times 273^2 \times P_c)$ .

An inspection of Table IX will, I think, convince all that molecular cohesion, as expressed by the value "a" of van der Waals' equation, is a function of the weight and valence of the molecule. If "a" is calculated for all these substances from the critical temperature and pressure by the formula:  $a = 27T_c^2/64P_c \times 273^2$ , the number of valences is calculated, with a remarkable degree of approximation, from the assumption that  $a = CN^2Wt^{2/3}Val^{2/3}$ , by the formula given at the beginning of the table. It will be noticed that all associating substances give by this formula a larger number of valences than that calculated for the normal substance, and that the degree of excess of the number of valences is more or less proportional to the degree of association. Thus the largest excess is in the case of water, where the cohesion calls for 22 valences, and in some of the nitriles; whereas substances like the esters, which associate very little, have only a few valences in excess. Putting aside associating substances, of which the deviation from the rule is to be expected, there are certain exceptions characteristic of certain observers. The coefficient  $3.2 \times 10^5$  was taken from Young's data for ether. It will be seen that always Nadejdine's critical constants give a value for "a" lower than Young's, where both observers have worked on the same substances. So the substances computed from Nadejdine's critical data generally show a deficit of two or three valences to the molecule. I think in these cases Young's values are to be accepted. Vincent and Chappuis' determinations, also, generally come a little low, though they are very close. The main constant deviation from the law is to be observed in the case of substances like methane and hydrogen of very low molecular weight and great molecular simplicity; and those substances

TABLE IX  
 Computation of the number of valences per molecule from the molecular cohesion by the formula: Valences =  $d^{3/2} \times 3.2 \times 10^5 / (\text{molecular weight})$

Substance	Formula	Value of "a"	Computed valences	Theoretical valences	Observer	Remarks
Ether	$C_2H_{10}O$	0.03473	28	28	Young	
Ethyl acetate	$C_4H_8O_2$	0.04076	29.9	28	Young	
Ethyl acetate	$C_4H_8O_2$	0.03897	27.98	28	Nadejdine	
Ethane	$C_2H_6$	0.01060	11.64	14	Olszewski	
Ethane	$C_2H_6$	0.01189	13.83	14	Dewar	
Acetone	$C_3H_6O$	0.02774	25.49	20	Sajotschewsky	Associated
Acetone	$C_3H_6O$	0.02459	21.3	20	Sajotschewsky	
Acetylene	$C_2H_2$	0.008745	10.06	10		
Acetonitrile	$C_2H_3N$	0.03503	51.2	14	Guye & Mallet	Associated
Ethyl amine	$C_2H_7N$	0.01736	16.3	18	Vincent & C.	
Ethyl benzene	$C_8H_{10}$	0.05701	41.09	42	Altschul	
Ethyl butyrate	$C_8H_{16}O_2$	0.05993	40.47	40	Nadejdine	
Ethyl chloride	$C_2H_5Cl$	0.02174	15.92	16	Vincent & C.	Cl = 3
Ethylene	$C_2H_4$	0.00889	9.58	{12(?) {10(?)	Dewar	One carbon bivalent
Ethylene	$C_2H_4$	0.00877	9.39	18	Olszewski	Cl = 3
Ethylene chloride	$C_2H_4Cl_2$	0.03370	20.02	18		Associated
Ethyl formate	$C_3H_6O_2$	0.03122	23.85	22	Young	
Ethyl formate	$C_3H_6O_2$	0.02949	21.91	22	Nadejdine	
Ethylidene chloride	$C_2H_4Cl_2$	0.03090	17.57	18	Nadejdine	Cl = 3
Ethyl isobutyrate	$C_6H_{12}O_2$	0.05754	38.1	40	Nadejdine	
Ethyl propionate	$C_5H_{10}O_2$	0.05088	36.0	34	Young	Associated
Ethyl propionate	$C_5H_{10}O_2$	0.04861	33.62	34	Nadejdine	
Alcohol	$C_2H_6O$	0.02395	25.8	16	Young	Associated

TABLE IX (Continued)

Ammonia	NH <sub>3</sub>	0.00818	13.93	6	Nadejdine	Association				
Amyl formate	C <sub>8</sub> H <sub>16</sub> O <sub>2</sub>	0.05496	35.51	40	"	"				
Aniline	C <sub>6</sub> H <sub>7</sub> N	0.05282	41.77	34		Slt. association				
Anisol	C <sub>7</sub> H <sub>8</sub> O	0.05645	39.79	38	Young	Cl = 3				
Benzene	C <sub>6</sub> H <sub>6</sub>	0.03726	29.51	30	Young	Cl = 3				
Chlorine	Cl <sub>2</sub>	0.01157	5.62	6	Young	Cl = 3				
Chlorbenzene	C <sub>6</sub> H <sub>5</sub> Cl	0.05083	32.61	32	Young	Cl = 3				
Carbon tetrachloride	CCl <sub>4</sub>	0.03735	17.27	16	Sajotschewsky	Cl = 3				
Chloroform	CHCl <sub>3</sub>	0.02930	13.45	14	Vincent & C.	Cl = 1. Association				
Hydrochloric acid	HCl	0.00621	4.3	2		Association				
Metacresol	C <sub>7</sub> H <sub>8</sub> O	0.06254	46.0	38						
Decane	C <sub>10</sub> H <sub>22</sub>	0.09675	67.8	62						
Cymol	C <sub>10</sub> H <sub>18</sub>	0.08403	58.2	54						
Diisobutyl	C <sub>8</sub> H <sub>18</sub>	0.06963	51.6	50	Young					
Diethylamine	C <sub>4</sub> H <sub>11</sub> N	0.03385	27.3	30	Vincent & C.					
Diisopropyl	C <sub>6</sub> H <sub>14</sub>	0.04596	36.7	36						
Dimethyl amine	C <sub>3</sub> H <sub>9</sub> N	0.01922	18.95	18						
Dimethyl aniline	C <sub>8</sub> H <sub>11</sub> N	0.07473	54	46	Guye & Mallet	Some association				
Dimethyl orthotoluidine	C <sub>9</sub> H <sub>13</sub> N	0.08194	55.6	52	Guye & Mallet	Some association				
Diphenyl	C <sub>12</sub> H <sub>10</sub>	0.10520	71	58	Guye & Mallet	Some association at				
Diphenyl methane	C <sub>13</sub> H <sub>12</sub>	0.1190	78.2	64	Guye & Mallet	low temperatures				
Diphenylamine	C <sub>9</sub> H <sub>12</sub> N	0.05524	41.1	42	Vincent & C.					
Durol	C <sub>10</sub> H <sub>14</sub>	0.09032	64.8	54	Guye & Mallet					
Fluorbenzene	C <sub>6</sub> H <sub>5</sub> F	0.03972	26.4	30	Young					
Heptane	C <sub>7</sub> H <sub>16</sub>	0.06143	48.7	44	Young					
Hexane	C <sub>6</sub> H <sub>14</sub>	0.04928	40.7	38	Young					
Hexamethylene	C <sub>6</sub> H <sub>12</sub>	0.04349	34.6	36	Young					
Isoamylene	C <sub>6</sub> H <sub>10</sub>	0.03604	31.3	30	Nadejdine					
Isobutyl acetate	C <sub>8</sub> H <sub>16</sub> O <sub>2</sub>	0.05680	37.4	40	Nadejdine					

TABLE IX (Continued)

Substance	Formula	Value of $\frac{1}{d}$	Computed valences	Theoretical valences	Observer	Remarks
Isobutyl alcohol	$C_4H_{10}O$	0.03394	27.04	28	Nadejdine	
Isobutyl benzene	$C_{10}H_{18}$	0.07692	50.95	54	Altschul	
Isobutyl formate	$C_5H_{10}O_2$	0.04492	29.9	34	Nadejdine	
Isopentane	$C_5H_{12}$	0.03650	31.0	32	Young	
Isopropyl alcohol	$C_3H_8O$	0.02747	24.3	22	Nadejdine	
Isopropyl benzene	$C_9H_{12}$	0.07105	50.5	48	Altschul	
Iodobenzene	$C_6H_5I$	0.06590	42.1	42	Young	
Carbon dioxide	$CO_2$	0.00719	4.43	6?	Dewar	
Carbon monoxide	$CO$	0.00285	1.28	2?	Olszewski	
Carbonoxysulfide	$COS$	0.00784	3.70	6?	Olszewski	
Mesitylen	$C_9H_{12}$	0.06840	47.7	48	Altschul	
Methane	$CH_4$	0.00376	4.6	8	Olszewski	
Methyl acetate	$C_3H_6O_2$	0.03206	24.8	22	Young	Slt. association
Methyl acetate	$C_3H_6O_2$	0.03047	23.0	22	Nadejdine	
Methyl ether	$C_2H_6O$	0.01609	14.2	16	Leduc & S.	
Methyl ethyl ether	$C_3H_8O$	0.02381	19.6	22	Nadejdine	
Methyl alcohol	$CH_3O$	0.01895	26	10	Young	Association
Methyl amine	$CH_5N$	0.01441	17.9	12	Vincent & C.	Association
Methyl butyrate	$C_7H_{14}O_2$	0.05082	35.9	34	Young	
Methyl chloride	$CH_2Cl$	0.01332	9.8	10	Vincent & C.	Cl = 3
Methyl fluoride	$CH_2Fl$	0.00923	8.4	8	Collie	Fl = 1
Methyl formate	$C_2H_4O_2$	0.02371	19.47	16	Young	Association
Methyl formate	$C_2H_4O_2$	0.02160	16.9	16	Nadejdine	
Methyl isobutyrate	$C_5H_{10}O_2$	0.04882	33.8	34	Young	
Methyl propionate	$C_4H_8O_2$	0.03968	28.75	28	Young	
Methyl valerate	$C_6H_{12}O_2$	0.05771	38.2	40	Nadejdine	
Naphthalin	$C_{10}H_8$	0.07928	55.8	48	Guye & Mallet	
Octane	$C_8H_{18}$	0.07284	55.2	50	Young	

TABLE IX (Continued)

Pentane	$C_5H_{12}$	0.03789	32.8	32	Young	Some association
Phenetole	$C_8H_{10}O$	0.07009	48.7	44	Guye & Mallet	Association
Phosphorus hydride	$PH_3$	0.00939	8.6	6	Leduc & S.	Association
Propane	$C_3H_8$	0.01760	17.0	20	Olszewski	Slt. association
Propionitrile	$C_3H_5N$	0.04279	51.5	20	Guye & Mallet	Associated
Propyl acetate	$C_5H_{10}O_2$	0.05149	36.7	34	Young	Associated
Propyl acetate	$C_5H_{10}O_2$	0.04908	34.1	34	Nadejdine	Associated
Propyl alcohol	$C_3H_8O$	0.03250	31.25	22	Young	Cl = 1
Propyl amine	$C_3H_7N$	0.02729	24.45	24	Vincent & C.	Slt. association
Propyl benzene	$C_9H_{12}$	0.07146	50.9	48	Altschul	S = 6
Propyl chloride	$C_3H_7Cl$	0.02819	19.31	20	Vincent & C.	Associated
Propyl formate	$C_4H_8O_2$	0.04086	29.7	28	Young	S = 4
Pseudo-cumole	$C_9H_{12}$	0.07298	52.6	48	Altschul	N = 1; O = 1
Oxygen	$O_2$	0.00273	1.4	2?	von Wroblewski	N = 2; or N = 1
Carbon bisulphide	$CS_2$	0.02316	14.8	16	Batelli	N = 1
Hydrogen sulphide	$H_2S$	0.00876	7.72	4	Leduc & S.	Associated
Sulphur dioxide	$SO_2$	0.01316	7.6	8	Sajotschewsky	Associated
Hydrogen selenide	$H_2Se$	0.01050	4.2	4	Olszewski	Associated
Nitric oxide	$NO$	0.00257	1.4	2(?)	Olszewski	Associated
Nitrous oxide	$N_2O$	0.00710	4.35	4(?)	Villard	Associated
Nitrogen	$N_2$	0.00277	1.67	2(?)	Olszewski	Associated
Thiophen	$C_4H_4S$	0.04130	32	22	Pawlewski	Associated
Toluene	$C_7H_8$	0.04795	36.5	36	Altschul	Associated
Triethylamine	$C_6H_{15}N$	0.05415	39.9	42	Vincent & C.	Associated
Trimethylamine	$C_3H_9N$	0.02594	22.7	24	Vincent & C.	Associated
Water	$H_2O$	0.01149	21.9	4	Cailltet & C.	Associated
Hydrogen	$H_2$	0.00042	1.38	2	Olszewski	Associated
<i>o</i> -Xylol	$C_8H_{10}$	0.05974	44.1	42	Altschul	Associated
Stannic chloride	$SnCl_4$	0.05365	15.25	16	Young	Cl = 3

studied by Guye and Mallet<sup>1</sup> of very high molecular weight and complexity, such as durol, cymol, diphenyl and diphenyl methane. So far as I can find, the evidence is that these substances associate but little; so the deviation cannot be attributed to that. It may be that Guye and Mallet's determinations have some constant source of error which brings them higher than determinations on similar substances by Altschul, but I do not think this is the explanation of the facts. The fact that the deviation is in the opposite direction in the simplest from what it is in the most complex substances leads me to believe, as stated on page 192, that the calculation of "a" by this formula may be at fault.

While there can be little doubt that this formula gives a value for "a" approximately correct for all normal substances, as van der Waals has recently reaffirmed, and accordingly that the ratio 27/64 is at least approximately true for all substances, yet it is not certain that this ratio is exactly constant for all substances. It can only be strictly justified for the simplest substances in which "b," the volume of the molecule, is constant. I believe it to be far more likely that this ratio changes a little with progressive increase in molecular complexity, and a resulting greater compressibility of the molecule, as indeed van der Waals has suggested, than that the law, which I have here attempted to establish, of the dependence of cohesion on molecular weight and valence holds strictly only for substances of medium complexity. This relationship of cohesion to these two molecular properties seems so probable and so fundamental that I believe we may, with some confidence, anticipate that if it holds at all, it holds everywhere.

It seems not worth while to consider this question further until it is decided whether "a" is in all instances determined by the formula just mentioned; or whether the ratio 27/64 is true only for the simplest substances with constant molecular volume, that is a constant "b;" and that for more complex

<sup>1</sup> Guye and Mallet: *Comptes rendus*, 133, 1288 (1901); 134, 168 (1902).

and compressible molecules it must be slightly diminished as the complexity and compressibility increases. If the latter shall prove to be the case, then most of the exceptions noted in the preceding pages would disappear. The substitution of the value for "M<sup>2</sup>K" computed by my formula from the surface tension would have given a much closer agreement of the calculated and observed valence numbers, but I wished to show that the law holds at least approximately even though we use the approximate values of "a" computed by the usual formula.

The constant  $2.98 \times 10^{-37}$  discovered in the foregoing pages, is evidently the factor M<sup>2</sup>K of a substance of unit molecular weight and unit valence. No such substance as this is known, but hydrogen with a weight and valence of two, and helium with a weight of four and valence of unity(?) have values of M<sup>2</sup>K not very different. Thus for hydrogen,<sup>1</sup> M<sup>2</sup>K is between 3.16 and  $7.72 \times 10^{-37}$ ; and M<sup>2</sup>K of helium lies between the same two values probably. The value of  $2.98 \times 10^{-37}$  is of the order of magnitude of the gravitational attraction of two average molecules. Thus at 20° two molecules of ether in the liquid state attract each other gravitationally with a force of  $3.11 \times 10^{-37}$  dynes. The similarity of these values is, however, probably only a coincidence.

#### Conclusion

The facts presented in the foregoing pages enable us to draw the general conclusion: The "mass" of cohesion of a molecule is everywhere proportional to the cube root of the molecular weight multiplied by the cube root of the number of valences in the molecule. Or, to put it in another way, "a" of van der Waals' equation for one cc. of gas under standard conditions is equal to  $2.98 \times 10^{-37} \times \text{Mol. Wt}^{2/3} \times \text{Valences}^{2/3} \times (2.77 \times 10^{10})^2$  dynes; or this number divided

<sup>1</sup> M<sup>2</sup>K for H<sub>2</sub> computed from the value "a" given by Landolt-Börnstein is  $5.55 \times 10^{-37}$ . This was computed by the formula  $a = \frac{27 T_c^3}{64 \times 273^2 \times P_c}$ .

by  $1.0135 \times 10^6$  atmospheres. This formula gives a value for "a" somewhat higher than the ordinary formula and it may be that the coefficient should be taken a little lower.

The theoretical significance of this relationship of cohesion to the molecular weight and the number of valences is very interesting, but I shall reserve its consideration for a subsequent paper.

*University of Chicago*



## THE PHOTOSENSITIVENESS OF FEHLING'S SOLUTION

BY ALAN LEIGHTON

In a discussion of Fehling's solution, Byk<sup>1</sup> points out that Fehling's solution is decomposed by light having a wavelength of something less than  $400\mu$ , while it is not sensitive to light corresponding to the absorption band in the red and yellow.

"The sensitiveness of Fehling's solution to light and the consequent precipitation of cuprous oxide was noticed by Fehling<sup>2</sup> himself and was afterwards studied carefully by Eder.<sup>3</sup> It is necessary to find out to what rays the solution is sensitive. Since the sensitiveness to light is relatively slight, experiments were made to find the most sensitive mixture of caustic soda, Seignette salt and copper sulphate solution. In consequence the solution used in the later experiments was always made up in the following way: Forty grams of crystallized copper sulphate were dissolved in water and the solution diluted to 200 cc; 200 grams Seignette salt were dissolved to make 400 cc solution. To 15 cc of the Seignette salt solution there were added 2.5 cc copper solution and then 10 cc of a ten percent caustic soda solution. To increase the absolute effect of the light, the solution under examination was illuminated from all sides. A stoppered cylinder containing the Fehling solution was placed in a beaker which could be filled with colored liquids to act as ray filters and to cut off special portions of the solar spectrum. The thickness of this outside solution was about 5 cc. To prevent the direct daylight from acting on the solution, black paper was placed over the top of the beaker and down the

<sup>1</sup> Zeit. phys. Chem., 49, 659, 679 (1904).

<sup>2</sup> Liebig's Ann., 72, 108 (1849).

<sup>3</sup> Sitzungsber. Akad. Wiss. Wien, 92, 344 (1885). Eder showed that a sensitiveness to light existed also in dilute solutions containing 0.02 gram-atom of copper and 0.1 gram-molecule of tartaric acid per liter. It is to be noted that the Fehling's solution of the ordinary composition is only very slightly sensitive.

sides to just below the level of the ray filter solution. When 20 cc of the standard solution were exposed to daylight without any ray filter solution, a distinct precipitation of cuprous oxide could be noted in one to two days.

"Since the deeply colored Fehling's solution shows strong absorption in the red and yellow, it was thought at first that these rays would be the ones which were photochemically active. Therefore two ray filter solutions were prepared, such that one of them cut out completely the rays absorbed by Fehling's solution, the red end of the spectrum, while the other let the red rays pass and cut off the violet rays. The first solution was Fehling's solution itself, made up of 200 cc Seignette salt solution, 100 cc copper solution and 400 cc 10 percent NaOH; the second ray filter solution consisted of 0.12 percent tartrazin. When these two solutions were placed one behind the other, they allowed a band in the green to pass, so that the two sets of transmitted rays overlap a bit. It is therefore certain that every ray of the visible spectrum can pass through one or the other of the solutions. Consequently, the photochemical effect must be obtained with one ray filter or the other in case the action is due to rays from the visible spectrum. To my great surprise there was no precipitation of cuprous oxide in either case<sup>1</sup> even long after precipitation had occurred in a control experiment with no ray filter solution. The photochemically active rays must therefore be outside the visible spectrum.

"Since Fehling's solution absorbs the red end of the spectrum and lets the violet through, it was thought at first that the ultra-red rays might be the active ones. To test this, the solution was illuminated behind a filter which cut off the ultra-red absolutely. Distilled water was selected as the absorbing liquid, but this lets through the shortest of the ultra-red rays. At the suggestion of Professor Rubens, to whom I express my thanks, enough ferrous chloride was added to

<sup>1</sup> [The selection of Fehling's solution for a ray filter seems fundamentally wrong.—A. L.]

the water to make the solution distinctly green. To prevent the oxidation of the ferrous salt during the long experiment, a solution of acidified stannous chloride was added while a layer of kerosene cut down the rate of diffusion of oxygen. Under these conditions the solution remained permanently greenish and no ferric salt could be detected even after several days. With this filter in place the photochemical change took place readily. This made it certain that the action must be due to ultra-violet rays.

"If that is the case, the precipitation of cuprous oxide must be prevented by the use of a ray filter which cuts off the ultra-violet. The addition of quinine sulphate makes distilled water opaque to ultra-violet. As a matter of fact, a one percent solution of quinine sulphate acidified with a little sulphuric acid protects Fehling's solution from the action of the sun's rays. The active rays are therefore really in the ultra-violet. In addition to an upper limit of about  $400\mu\mu$  for the wave-length of the active light, we can also give a lower limit. According to Precht<sup>1</sup> a tartrazin solution absorbs chiefly the wave-lengths  $495-362.5\mu\mu$  but cuts down the rays as far as  $352.5\mu\mu$ . Since tartrazin protects Fehling's solution, the active wave-lengths must be above  $350\mu\mu$  and there must be a maximum sensitiveness between  $400\mu\mu$  and about  $350\mu\mu$ .

"If the photochemical absorption law holds, there must also be a strong optical absorption in this region. To prove this, spectrum photographs were made on silver bromide gelatine plates using a grating photograph. In one case the sunlight passed through a layer of distilled water, one centimeter in thickness; the second time it passed through an equal thickness of Fehling's solution. Varying the absolute times of exposure brought out the fact that in all cases the plate behind the water blackened farther into the ultra-violet than did the plate behind Fehling's solution. There is therefore a region of increasing absorption in the ultra-violet. In one

<sup>1</sup> Zeit. wiss. Photographie, 1, 262 (1903).

exposure behind Fehling's solution, no sign of a blackening could be found beyond  $359\mu$ , while behind the water layer the blackening could be followed down to  $341.5\mu$ . There is therefore a strong optical absorption over the range of photo-chemical activity. This is the more remarkable because one would not have suspected the existence of an absorption band in the ultra-violet so near the visible spectrum in the case of a solution like Fehling's solution which lets the blue and violet through completely and absorbs the red and yellow."

The decomposition of Fehling's solution by the longer ultra-violet rays and the failure of the red and yellow rays to cause a reduction seems, at first, not to be in agreement with the generalization that all radiations which are absorbed by a substance tend to eliminate that substance.<sup>1</sup> The discrepancy disappears if we show that the red and yellow rays do tend to decompose Fehling's solution but that they are not powerful enough, under the conditions of the experiment, to produce actual decomposition unaided. Bennett<sup>2</sup> has proved that light reduces copper sulphate solutions in presence of a dilute solution of phosphorus in ether, and that "the effect due to light is superposed on the effect due to the reducing agent, thereby making possible reductions which would not take place in the dark."

Following out this idea it was thought advisable to add a reducing agent to the Fehling solution in quantities too small to bring about definite reduction in the dark, and then to subject the solution to the action of red light in order to see whether the combined action of red light and reducing agent would cause reduction to cuprous oxide.

The Fehling solution was made up according to Byk. Solution A consisted of 40 grams crystallized copper sulphate in 200 cc; solution B of 200 grams sodium potassium tartrate in 400 cc; and solution C of 20 grams NaOH in 200 cc. A solution was also made up which contained ten grams of hydroquinone per liter.

<sup>1</sup> Bancroft: *Internat. Congress Applied Chemistry*, 20, 33 (1912).

<sup>2</sup> *Jour. Phys. Chem.*, 16, 785 (1912).

In small bottles there were placed a Fehling solution consisting of 2.5 cc A, 15 cc B and 10 cc A. Varying amounts of the hydroquinone solution were added to different bottles. One lot of bottles was placed in the dark while another set was exposed to the action of red light. The source of light was a 2.5 kw Macbeth carbon arc printing lamp. A potassium bichromate solution was used as a ray filter, cutting off all except the red end of the spectrum. To ensure effective screening, the bottles containing the Fehling solution were immersed in liter beakers containing the bichromate solution. The thickness of the ray filter solutions was about 4.5 cm.

The data and results are given in Table I.

TABLE I

Bottle No.	Fehling's solution cc	Hydroquinone cc	Subjected 15 hours to	Result
1	27.5	0.0	Direct light	Reduced
2	"	0.0	Red rays	No apparent red
3	"	0.0	Darkness	"
4	"	0.10	Red rays	"
5	"	0.20	"	"
6	"	0.30	"	"
7	"	0.40	"	"
8	"	0.60	"	Reduced
9	"	0.80	"	"
10	"	1.00	"	"
11	"	0.60	Darkness	"
12	"	0.80	"	"
13	"	0.40	Red rays	No apparent red
14	"	0.40	Darkness	"
15	"	0.45	Red rays	Reduced
16	"	0.45	Darkness	No apparent red
17	"	0.45	Red rays	Reduced
18	"	0.45	Darkness	No apparent red
19	"	0.45	Red rays	Reduced

In all cases the bottles were made up with quantitative accuracy and were left standing at the temperature of the room. In order to be certain that the experiments were not vitiated by temperature fluctuations, the check bottles, which

were kept dark, were always made up at the same time as the others and were tested along with them.

From the data concerning Nos. 15-19 inclusive, reduction takes place when a Fehling solution containing 0.45 cc hydroquinone solution is exposed to red light, whereas no reduction to cuprous oxide takes place if the solution is kept in the dark.

The results of this paper are:

1. By adding a suitable amount of hydroquinone to a specified Fehling solution, the solution is reduced by the action of red light, whereas the solution is not reduced if kept in the dark.

2. Since red light actually reduces a specified Fehling solution to which a suitable amount of hydroquinone has been added, the red light must tend to reduce the same Fehling solution to which no hydroquinone has been added.

3. The case of Fehling's solution is not an exception to the generalization that all radiations which are absorbed by a substance tend to eliminate that substance.

4. Another case has been studied in which reduction is caused by the combined action of a certain light and a certain reducing agent whereas no reduction by the action of the light alone or by the reducing agent alone when used at that concentration.

This investigation was suggested by Prof. Bancroft and has been carried on under his supervision.

*Cornell University*

## A QUANTITATIVE STUDY OF SOME PHOTOCHEMICAL EFFECTS PRODUCED BY ULTRA-VIOLET LIGHT<sup>1</sup>

BY J. HOWARD MATHEWS AND LEON H. DEWEY

The object of this investigation was to follow, quantitatively, the decomposition and oxidation of various solutions under the action of ultra-violet light. For this purpose solutions of sodium sulphite, potassium permanganate, potassium dichromate, and oxalic acid were used.

A Cooper-Hewitt quartz mercury vapor lamp was used as the source of ultra-violet rays. The lamp was run on a direct current and used three amperes with a potential drop across the terminals of 70 volts. Care was exercised to keep the current strength constant, as the velocity of the reactions studied is so highly dependent upon the strength of the illumination.

The flasks containing the solutions to be worked with were made of transparent quartz, a material which allows the ultraviolet rays to pass freely. They were supported in direct light of the lamp at a distance of 10 cm. Due to the considerable amount of heat generated by the lamp in action, and the heat effect produced by the absorption of the rays, the temperature had to be controlled. This was accomplished by supporting a water-bath immediately under the lamp, connecting it with a water tap and so regulating the flow of water as to keep a constant temperature in the bath. The temperature of the water was kept at about 20°. The quartz flasks were supported on floats in this bath in such a manner that one-half of their surface was exposed to the light, the other being exposed to the cooling action of the water. A thermometer kept in the solution indicated its exact temperature. It was found possible to maintain a constant temperature of  $25^{\circ} \pm 1.5^{\circ}$ , which was close enough

<sup>1</sup> A paper read before the Eighth International Congress of Applied Chemistry in New York, September, 1912.

as temperature coefficients of photochemical reactions are small.

The solutions used were 0.1 normal. In titrating the weight burette was used. The water from which the solutions were prepared was specially distilled from the city water supply; potassium permanganate was added to the water before distillation, and the first third of the distillate rejected.

#### Sodium Sulphite

A liter of 0.1 normal sodium sulphite was divided into two portions of 500 cc. each and placed in glass-stoppered liter flasks. One of these was placed in the dark and the other placed in daylight. The solutions were titrated at intervals with a 0.1 normal solution of resublimed iodine. The solution in the light oxidized completely in four days' time, while that portion of the same solution which was kept in the dark for the same period of time was but about half oxidized. From this it was very evident that the oxidation of sulphite solutions is greatly accelerated by light.

Separate experiments in which the containing vessels were entirely filled with the solutions showed that in the absence of air the oxidation is but very slight. This slight oxidation is, of course, due to the oxygen contained in the water.

For the study of the effect of ultra-violet light on the oxidation of sodium sulphite solutions, a 0.1 normal solution contained in a quartz flask was placed under the light. It was found that the ultra-violet light has a decidedly accelerating influence on the reaction. The oxidation proceeded about twenty times as rapidly in this light as in the ordinary light of the laboratory.

In order to determine whether there might not be an autoxidation of the sulphite in the ultra-violet light, a 0.1 normal solution prepared from boiled water was placed in a quartz flask, care being taken to completely fill the flask. Exposure to the light for six hours produced no appreciable oxidation.



#### **Potassium Permanganate**

Solutions of potassium permanganate are usually considered quite stable, although it is known that upon long standing they do change somewhat.

A rather strong solution of potassium permanganate was subjected to the action of ultra-violet light for seven hours. It was titrated before and after exposure with a standard solution of oxalic acid, in presence of sulphuric acid. A slight reduction of the strength of the solution was evident, and a deposit of oxide appeared on the walls of the vessel.

#### **Potassium Bichromate**

Six hours exposure of a 0.1 normal solution of potassium bichromate to the ultra-violet rays produced no change whatever in the strength of the solution.

#### **Decomposition of Oxalic Acid**

Solutions of oxalic acid when placed in ultra-violet light are but very slowly decomposed. However, if a uranium salt be present the reaction is greatly accelerated. A series of determinations of the rate of decomposition of oxalic acid solutions with varying amounts of uranium salts and with salts of uranium containing different acid radicles was made. The nitrate, sulphate and acetate were used. The oxalic acid solutions were 0.1 normal, and were titrated with 0.1 normal solutions of potassium permanganate.

In the first experiment, a solution containing approximately 0.5 gram of uranium nitrate per 100 cc of 0.1 normal oxalic acid was used. In the first series of titrations considerable trouble was experienced in keeping the intensity of the light constant. This fact accounts for the irregularity shown in the curve (Fig. 1). During the first two hours the pressure was low, after which it increased while the batteries were being charged until at the third hour the maximum was reached. At the end of the fifth hour the pressure began to fall off again, and the rate of decomposition of the acid decreased correspondingly, all of which is well shown on the graph.

In a later series, using the same concentration of uranium nitrate, no difficulty was experienced in the regulation of the light, and the curve plotted from the data obtained was perfectly linear.

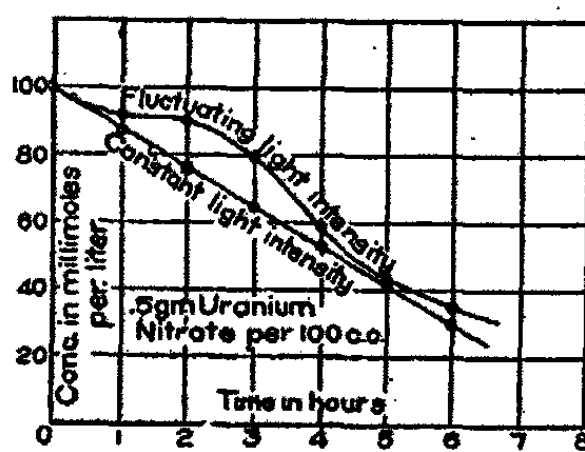

Fig. 1

Oxalic acid with varying amounts of uranium nitrate were then subjected to the action of the ultra-violet rays, with the results shown in the accompanying tabulations and the graphs plotted therefrom.

SERIES NO. 1.—CONTAINING 0.5 GRAM URANIUM NITRATE IN 100 CC OF SOLUTION

Time of titration	Millimols of acid present per liter
10.45 A.M.	100.0
11.45 A.M.	85.0
12.45 P.M.	74.9
1.45 P.M.	65.0
2.45 P.M.	56.3
3.45 P.M.	48.5
4.45 P.M.	33.4

SERIES NO. 2.—CONTAINING 0.25 GRAM URANIUM NITRATE IN 100 CC OF SOLUTION

Time of titration	Millimols of acid present per liter
11.00 A.M.	100.0
12.00 M.	96.0
1.00 P.M.	90.5
2.00 P.M.	85.5
3.00 P.M.	79.4
4.00 P.M.	73.8
5.00 P.M.	65.0

SERIES NO. 3.—CONTAINING 0.1 GRAM OF URANIUM NITRATE IN 100 CC OF SOLUTION

Time of titration	Millimols of acid per liter
8.00 A.M.	100.0
9.00 A.M.	97.0
10.00 A.M.	92.0
11.00 A.M.	88.8
12.00 M.	86.5
1.00 P.M.	85.0
2.00 P.M.	77.8

Fig. 2 shows, graphically, the results given in the above tables. It will be observed that the curves are linear, the rate of decomposition being constant.

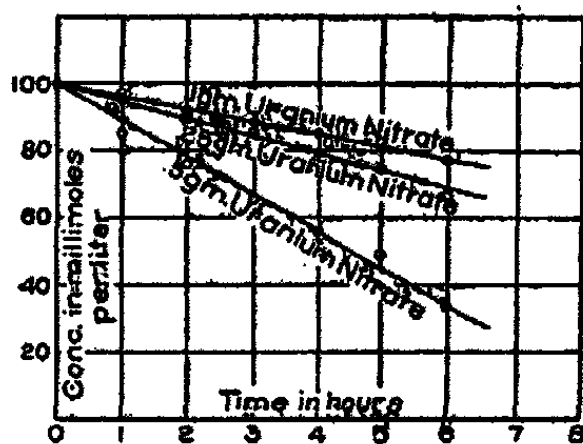

Fig. 2

The next series of determinations were made with uranium sulphate as catalyzer. Since it is the uranium which is the active agent in accelerating the reaction, care was taken to use equimolecular amounts of the different salts.

SERIES NO. 4.—CONTAINING 0.427 GRAM URANIUM SULPHATE IN 100 CC OF SOLUTION

Time of titration	Millimols of acid per liter
10.00 A.M.	100.0
11.50 A.M.	93.0
12.50 P.M.	76.8
1.50 P.M.	65.8
2.50 P.M.	50.7
3.50 P.M.	39.9
4.50 P.M.	27.8

SERIES NO. 5.—CONTAINING 0.214 GRAM URANIUM SULPHATE IN  
100 CC OF SOLUTION

Time of titration	Millimols of acid per liter
11.00 A.M.	100.0
12.00 A.M.	95.0
1.00 P.M.	89.0
2.00 P.M.	81.8
3.00 P.M.	75.2
4.00 P.M.	68.2
5.00 P.M.	59.5

SERIES NO. 6.—CONTAINING 0.085 GRAM URANIUM SULPHATE IN  
100 CC OF SOLUTION

Time of titration	Millimols of acid present per liter
8.45 A.M.	100.0
9.45 A.M.	95.2
10.45 A.M.	91.4
11.45 A.M.	87.3
12.45 P.M.	82.5
1.15 P.M.	80.2

The curves for the sulphate solutions, Fig. 3, show the same regularity in rate of decomposition as previously found with the nitrate of uranium. The more uranium present the faster is the decomposition.

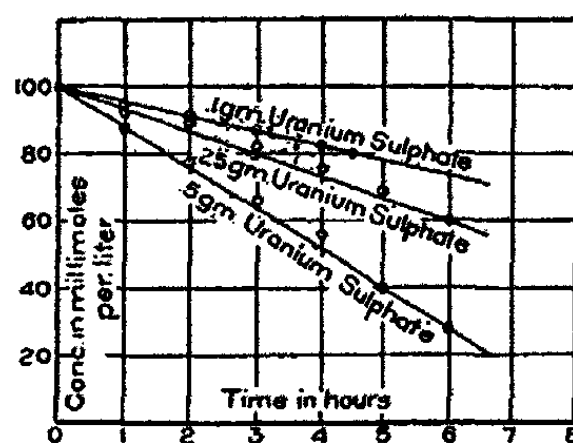

Fig. 3

The final series of measurements was made with uranium acetate as the catalyzer, the amounts used being varied as before.

**SERIES NO. 7.—CONTAINING 0.422 URANIUM ACETATE IN 100 CC OF SOLUTION**

Time of titration	Millimols of acid present per liter
8. 15 A.M.	100.0
9. 15 A.M.	90.0
10. 15 A.M.	77.0
11. 15 A.M.	69.8
12. 15 P.M.	59.0
1. 15 P.M.	48.5
2. 15 P.M.	38.9

**SERIES NO. 8.—CONTAINING 0.084 GRAM OF URANIUM ACETATE IN 100 CC OF SOLUTION**

Time of titration	Millimols of acid present per liter
11. 00 A.M.	100.0
12. 00 M.	96.0
1. 00 P.M.	93.0
2. 00 P.M.	89.8
3. 00 P.M.	84.9
4. 00 P.M.	78.5
5. 00 P.M.	72.6

**SERIES NO. 9.—CONTAINING 0.211 GRAM OF URANIUM ACETATE IN 100 CC OF SOLUTION**

Time of titration	Millimols of acid present per liter
10. 45 A.M.	100.0
11. 45 A.M.	90.5
12. 45 P.M.	81.8
1. 45 P.M.	73.0
2. 45 P.M.	65.0
3. 45 P.M.	57.5
4. 45 P.M.	46.8

The decomposition of the oxalic acid with uranium acetate as the catalyzer proceeds regularly, as with the other salts of uranium. Other radio-active salts should be tried to ascertain whether this property is limited to uranium compounds, or whether it is common to those possessing radio-activity. It may be that the rays given off from the

uranium throw the molecules into an unstable condition, which favors their decomposition by the light waves.

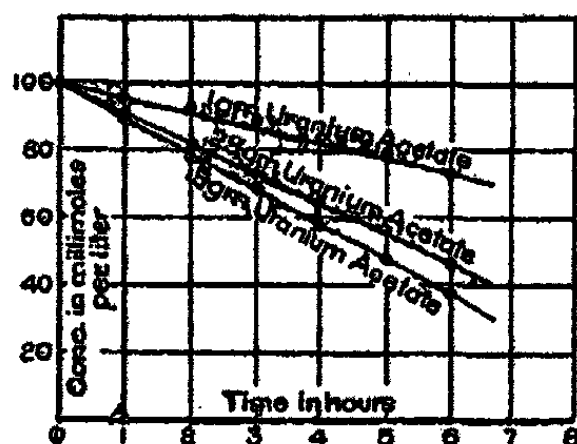

Fig. 4

From the experiments described in this paper it is concluded that:

1. The rate of decomposition of a solution by ultra-violet light is dependent upon the amount of light photochemically absorbed.
2. The rate of decomposition of the oxalic solutions in the presence of the catalytic uranium salts varies directly with the amount of uranium salt used.
3. The salts potassium permanganate and potassium bichromate are very stable toward ultra-violet light.
4. Sodium sulphite solutions do not oxidize (autoxidation) when air is kept away from them, even under the influence of ultra-violet light, but the oxidation in air is greatly accelerated by such light.
5. Possibly other radio-active elements might behave similarly to uranium in its accelerating action on the decomposition of oxalic acid.

*University of Wisconsin*

## STUDIES ON CELLULOSE

BY EDWARD G. PARKER

The statement is made in text-books that cellulose is distinguishable by its non-reactivity to ordinary reagents. Methods of analysis start upon this assumption, removing the non-celluloses by more or less drastic means, leaving the basal fiber or cellulose itself untouched.

The portions which are removed are either hydrolyzed or oxidized, thus being rendered soluble. Excepting the elementary analysis of cellulose, there is in no method a complete reaction. Since hydrolysis and oxidation are not separate and distinct actions each due to definite reagents, but are rather parallel and coexisting with nearly all reagents used, it seems better to divide analytical methods for the determination of cellulose into

- A. Those depending upon acids.
- B. Those depending upon bases.

The general reactions involve oxidation and solution where acids are employed, hydrolysis and solution where bases are used. The normal cellulose is least subject to those influences and remains as a fairly inert residue. It is, however, undoubtedly attacked to a certain extent, being converted, at least superficially, into oxy- and hydrocellulose, as shown: chemically by reaction with Fehling's solution (the CO group of oxycellulose), and the fixation of basic aniline dyes (methylene blue); physically by a change from long fiber with definite microscopic characteristics, to a more or less finely divided powder and short brittle fiber, depending upon the extent of the attack.

Under (A) there are mainly the methods of Schulze<sup>1</sup> (nitric acid and KClO<sub>3</sub> at 15° for 12 to 14 days); Müller<sup>2</sup> (bromine in diffused daylight at 20° for 2 to 3 days); Cross and

<sup>1</sup> Chem. Zentralblatt, 321 (1857).

<sup>2</sup> Die Pflanzenfaser, 27, 28.

Bevan<sup>1</sup> and modification of Dean and Tower<sup>2</sup> (chlorine).

These are based upon the main fact of oxidation and ultimate breaking down of the cellulose molecule completely. It therefore becomes a matter of choice, where any of them is to stop, and where the measure of the reaction is to be taken. This is especially true of methods depending upon the halogens, which invariably give lower results than those depending on the action of alkalies which follow, and upon which this work is based.

Under (B) we have mainly the methods of: Lange<sup>3</sup> (water and alkali, fusion at 180°); Hönig<sup>4</sup> (glycerine at 110°); Gabriel<sup>5</sup> (glycerine and alkali; a combination of Hönig and Lange methods); and the Weender process<sup>6</sup> or crude fiber method, which is most widely used, for the determination of fiber in plants and foodstuffs. It depends primarily upon the alternate action of dilute alkali (KOH) and dilute acid (H<sub>2</sub>SO<sub>4</sub>).

It is perfectly true that all methods for the isolation of normal cellulose are more or less arbitrary, and even slight deviations from procedure, in time, concentration, or temperature will affect materially the results obtained. It is evident, nevertheless, that the nearer we approach pure cellulose the slower the reaction becomes, leading us to believe that it is the non- and lignocellulosic constituents which give reactions their impetus and that when pure cellulose is reached a considerable period of time may elapse before the attack is recommenced.

We propose to show this in our work, by means of a modification of Lange's<sup>7</sup> method. Lange's original method is as follows:

---

<sup>1</sup> Cross and Bevan: Cellulose, 95.

<sup>2</sup> Jour. Chem. Soc., 29, 1119 (1907).

<sup>3</sup> Zeit. physiol. Chem., 14, 217 (1909).

<sup>4</sup> Chem. Ztg., 14, 868, 902 (1890).

<sup>5</sup> Zeit. physiol. Chem., 16, 270 (1891).

<sup>6</sup> Holdefleiss: Landwirtschaftl. Jahrbücher, Suppl., Band 103 (1887).

<sup>7</sup> Zeit. physiol. Chem., 14, 283 (1889); 16, 270 (1891).



"Ten grams of the original substance are placed in a large, deep, tubulated retort with 3-4 times its weight of pure KOH, and about 30-40 cc of H<sub>2</sub>O. This is then closed with a glass stopper, and heated in an oil bath. The temperature is measured by a thermometer placed in the bath, the bulb being on a level with the bottom of the retort. At about 140°, with considerable foaming, boiling begins. The temperature then rises little by little to about 180°. The heating is continued for about one hour. The foaming is then finished, and the mass falls together in the retort, then melts and finally dries. End of reaction. The retort is now taken from bath, the contents, after cooling to about 80° C, are taken up with hot water and washed carefully, first with repeated washings with hot water, and, finally, into a beaker with cold water. After cooling, the solution is acidified with dilute H<sub>2</sub>SO<sub>4</sub>, whereupon immediately a thick flocculent precipitate is formed consisting of small particles of cellulose, which had remained suspended in the strong alkali. Upon acidification the cellulose is precipitated out quantitatively. The contents of the beaker are now made slightly alkaline by the careful addition of NaOH, so that all the precipitated substance with the exception of the cellulose goes again into solution. The solution is now filtered with strong suction, through a sieve-like, fine-perforated, platinum cone. The residue left on the filter is washed first with hot and then with cold water, taken from the filter, and digested with alcohol, again filtered, and washed with ether, and finally dried and weighed. By ignition of the residue and subtraction of the weight of the product obtained, the pure cellulose content is obtained." In a later modification Lange<sup>1</sup> substituted a porcelain crucible 65 cm high for the retort and a centrifugal for suction, thus cutting down the time of operation from six to two and one-half hours.

This method has given widely varying results in the hands of different investigators, and, while it may give comparable

<sup>1</sup> *Zeit. angew. Chem.*, 19, 561 (1895).

results on different substances, slight variations of conditions (temperature and time), when used on the same substance, affect the results obtained to a considerable extent.

In Table I are some of the results obtained by J. J. Frank (of this University) with the method of Lange on pure cotton (Red Cross surgeon's absorbent cotton):

TABLE I.—5 GRAMS COTTON AND 20 GRAMS KOH

Time Hours	Temp.	H <sub>2</sub> O Grams	Yield Percent
I	180°	100	92.80
I	"	"	92.84
I	180°-210°	"	83.80
I	180°	40	91.40
I	"	"	82.00
I	"	"	88.20
0.5	210°	100	91.80
I	"	"	67.80
I	"	"	67.00
4.5	180°	"	43.32
4.5	"	"	42.60

These results do not meet the broadest analytical requirements and the method as such is apparently useless. The fault obviously lies in the fact that the concentration of caustic potash varies within wide limits, due to the fact that water is being driven off continually. Now if the concentration is kept constant, there is no reason why this method should not give results, and this work was carried on by modifying Lange's method in this respect. This was done by means of a reflux condenser connected to the vessel in which the action takes place.

Pure absorbent (surgeon's) cotton was used entirely in this work, and the method is as follows:

0.5-2.0 grams of the sample were weighed out, the moisture content being previously obtained from a separate sample, and placed in a 500 cc round-bottom flask (Jena glass). 50 cc of KOH solution were then added, the flask connected with a reflux condenser, and heated in a paraffin bath to the

desired temperature. The temperature of the bath was taken in each case, and was regulated by the height of the flame used;  $130^{\circ}$ – $140^{\circ}$  was the highest temperature of the bath which was used on long runs, due to serious bumping at higher temperature. The bath was maintained at that temperature for the time desired. The flask was then allowed to cool to about  $70^{\circ}$ – $80^{\circ}$ , and the contents washed into a beaker with distilled water. The cotton wool (which can be gathered together on a glass rod) was then washed with water and removed to a Gooch crucible, where it was washed thoroughly with dilute acid, dilute alkali, water, alcohol and ether. The residue was then dried in a water oven to constant weight.

Serious bumping took place at first, even at  $130^{\circ}$ – $140^{\circ}$ , which was overcome, first, by weighing the sample out in as compact a mass as possible, and, secondly, by means of a long glass rod extending down through the condenser to the bottom of the flask and resting on the sample near the center. This causes the steam evolved to pass up around the outside of the sample instead of being confined under it and thereby causing the bumping.

At the outset a 20 percent KOH solution was used in each case, and the time varied from one to 166 hours, the temperature of the bath with a few exceptions, being constant at  $130^{\circ}$ – $140^{\circ}$ . Moisture was previously determined on a separate sample of cotton and found to be, (1) 3.21 percent, (2) 3.34 percent. All results are calculated to air-dry conditions, so that a yield of about 96.7 percent means pure cellulose containing 3.3 percent water.

On inspection of the results obtained (Table II) it is seen that there is an appreciable drop in the percentage yield for the first 15 hours, but that after that the yield remains practically constant as far as investigated.

Normal cellulose is the basis of fibrous materials generally. Various modifications of it, oxy-, hydro- and ligno-cellulose, are associated with and give it chemical activity. All methods of determining fibre content of a substance are

TABLE II

Time Hours	Bath temp.	KOH Grams	H <sub>2</sub> O Grams	Yield Percent
1	170°-180°	10	50	96.66
	170°-180°	10	50	96.12
	130°-140°	10	50	96.02
2	170°-180°	10	50	95.92
	170°-180°	10	50	96.06
3	170°-180°	10	50	95.80
	170°-180°	10	50	95.76
4	170°-180°	10	50	95.42
	130°-140°	10	50	95.48
6	170°-180°	10	50	94.92
	130°-140°	10	50	95.00
8	170°-180°	10	50	94.50
	130°-140°	10	50	94.00
	130°-140°	10	40	94.10
12	170°-180°	10	50	93.60
	130°-140°	10	50	93.20
15	130°-140°	10	50	92.70
	130°-140°	10	50	92.60
18	130°-140°	10	50	92.60
20	130°-140°	10	50	92.64
24-25	130°-140°	10	50	92.70
37	130°-140°	10	50	92.40
48	130°-140°	10	50	92.02
72	130°-140°	10	50	92.80
92	130°-140°	10	50	92.80
100	130°-140°	10	50	92.54
140	130°-140°	10	50	92.60
166.5	130°-140°	10	50	91.80

based upon the premise that at the end of a certain time the reaction is to be made to stop, and the result at that point determined. If the reaction proceeds beyond that point the results are no longer comparable. On the other hand, the action of caustic potash appears to be divided into two definite stages:

- I. The period of first attack in which the superficial oxy-

and hydrocelluloses are dissolved (first 15 hours for concentration of KOH used).

2. The period in which the caustic potash is in contact with normal cellulose is without appreciable action so far as change in weight is concerned. It is in this period of constant weight that the true cellulose content may be arrived at.

Next a 10 percent KOH solution was used in each case and the time varied from 1 to 84 hours. The temperature of bath was kept constant at 130°-140°.

TABLE III

Time Hours	Bath temp.	KOH Grams	H <sub>2</sub> O Grams	Yield Percent
1	130°-140°	5	50	95.30
3	130°-140°	5	50	94.20
6	130°-140°	5	50	92.42
15	133°-140°	5	50	92.50
47	130°-140°	5	50	92.30
47	130°-140°	5	50	92.40
60	130°-140°	5	50	92.40
84.5	130°-140°	5	50	92.64

On inspection of the results obtained (Table III), it is seen that there is an appreciable drop in the percentage yield for the first 4 or 5 hours; but that after that the yield remains practically constant as far as investigated.

It is seen that in each case (20 percent and 10 percent KOH) the percentage yield drops practically to the same value, and then remains constant, the value for the 10 percent KOH being very slightly below that of the 20 percent KOH. But, however, contrary to what might be expected, the drop to this constant value is much quicker in the case of the 10 percent KOH, than in that of the 20 percent KOH.

In view of this fact, the time was next kept constant (3 hours), and the concentration of KOH solution was varied from a 20 percent solution to a 1 percent solution.

TABLE IV

Time Hours	Bath temp.	KOH Grams	H <sub>2</sub> O Grams	Yield Percent
3	130°-140°	10	50	95.80
3	130°-140°	5	50	94.20
3	130°-140°	3.5	50	93.38
3	130°-140°	1.25	50	92.90
3	130°-140°	0.50	50	93.00
3	130°-140°	0.50	50	92.70

Pure water was found to be without appreciable action on cotton, what action there was, being due probably to impurities in the glass used.

On inspection of the results obtained (Table IV), it is seen that by decreasing the concentration of the KOH, the percentage yield decreases with a certain degree of regularity as far as investigated.

An explanation of this may lie in the fact that the water is the important factor in the action, the non-celluloses being carried into suspension in the presence of the KOH. In the short runs no appreciable coloration of the solution is noticed, while in the long runs considerable coloration is noticed, this coloration pointing to the probability that decomposition has taken place, although the percentage yield is approximately the same in the short as in the long runs. This observation tends to bear out the explanation offered, the KOH reacting with the non-celluloses after they have been carried into suspension. Also there may be some dependence on the fact that the evolution of steam takes place at a much greater rate in the diluted solution, therefore an increased movement of entire contents of flask.

It is, of course, well known that cotton cellulose is soluble in cuprammonium (Schweitzer's reagent), from which it may be precipitated by acids or salts. In view of what was done with cotton—indicating that it was from 92-93 percent normal cellulose—it was desired to get at the changes, if any, involved in the solution of it. There was no reason to sup-

pose that reprecipitated cotton would show any marked changes toward alkali, if it were chemically the same. If not chemically the same it was hoped to show this in the yield after solution.

A strong cuprammonium solution was made up (copper hydroxide was precipitated from a solution of  $\text{CuSO}_4$ , to which was added  $\text{NH}_4\text{Cl}$ ). The blue precipitated  $\text{Cu}(\text{OH})_2$  was then filtered, and dried by means of filter cloth. It was then finally dissolved in  $\text{NH}_4\text{OH}$  (sp. gr. 0.92). Cotton wool was dissolved (apparently) in this solution and after standing, for varied periods of time, was precipitated by means of  $\text{H}_2\text{SO}_4$ . The precipitated substance was then filtered, washed thoroughly, and dried in a water oven, the dried substance being then ground in a mortar to a fine powder, and treated in a similar way to the cotton wool.

The dried substance was ground fine so that it would remain partially in suspension in the  $\text{KOH}$  solution, thereby alleviating the bumping, usually caused by the gathering of the substance in the bottom of the flask.

In some cases the solution was filtered before precipitation with acid, by means of asbestos in a Büchner funnel. It was thought that, perhaps by filling the pores of the filter up by consecutive filtering of the same solution, a partial separation of cotton which might be in suspension, and cotton which was in true solution, might be effected.

TABLE V.—COTTON WOOL REPRECIPITATED FROM SCHWEITZER'S REAGENT, WITHOUT FILTERING. TEMP. OF BATH,  $130^\circ$ - $140^\circ$ ; 5 GRAMS  $\text{KOH}$  PER 50 GRAMS  $\text{H}_2\text{O}$ .

Precipitated from Schweitzer's reagent	Time Hours	Digestion with $\text{KOH}$ at constant volume. Yield Percent
After 0 hours	24	80.32
" 0 "	6	76.36
" 4 "	6	32.04
" 15 "	6	42.52
" 18 "	6	31.21
" 24 "	6	15.45

COTTON WOOL REPRECIPITATED FROM SCHWEITZER'S REAGENT,  
WITH FILTERING. TEMPERATURE OF BATH, 130°-140°; 5  
GRAMS KOH PER 50 GRAMS WATER.

Precipitated from Schweitzer's reagent	Time Hours	Digestion with KOH at constant volume. Yield Percent
After 5 hours	24	19.95
" 6 "	6	29.47
" 13 "	24	30.72
" 15 "	6	21.98
" 15 "	6	52.95
" 18 "	6	26.95
" 30.5 "	24	24.66
" 45 "	6	36.19

From the results obtained (Table V) it is shown that cotton reprecipitated from Schweitzer's reagent is not the same as before, in regard to its action towards KOH. Other than this no conclusions can be drawn, since the results obtained show very clearly that some other condition or conditions must be regulated before anything definite can be concluded.

A sample of oxycellulose was prepared (HCl + KClO<sub>3</sub> in dilute solution at boiling point for one hour), and treated similarly to the reprecipitated cotton wool.

Time Hours	Bath temp.	KOH Grams	H <sub>2</sub> O Grams	Yield Percent
6 hours	130°-140°	5	50	30.22

This result shows that the substance obtained by the action of HCl + KClO<sub>3</sub> on cotton wool (presumably oxycellulose) is not the same as cotton wool in regard to its action with KOH.

Whether cotton cellulose in contact with Schweitzer's reagent in the open air is converted into oxycellulose, the amount depending upon the time of contact, cannot be said, but, from the work done, indications point in this direction.



The general results of this paper are:

1. The fusion method of Lange as originally proposed does not give sufficiently concordant results to be generally useful.

2. Slight variations of time, temperature and concentration of reagents in all other methods so far proposed are accountable for variations of cellulose yield, and therefore none of the methods are a true measure of normal non-reactive cellulose, but merely arbitrary approximations.

3. By use of a constant volume of KOH solution at a temperature of 130°-140°, after a certain interval of time, depending upon the conc. of the KOH solution, a constant yield of presumably normal cellulose is obtained from absorbent cotton. By this modification of the fusion method of Lange a criterion for normal cellulose in cotton wool is arrived at.

4. By varying the concentration of the KOH solution the time required to reach this constant yield is varied, the more dilute solution requiring the shorter time within the limits studied.

5. Further experiments will be necessary before one can tell whether this method is applicable to other forms of cellulose than the one studied.

6. Cotton, reprecipitated from Schweitzer's reagent, is changed so that it reacts more readily with caustic potash. The results are very irregular, showing that further study of the reaction is necessary.

7. Surgeon's cotton contains approximately 92-93 per cent normal cellulose, 4-5 percent of cellulose, etc., soluble in KOH, and 3.25 per cent moisture.

This investigation was suggested by Professor Bancroft and was carried on under his supervision.

*Cornell University*

## THE PRODUCTION OF PHOTOCHEMICALLY ACTIVE RAYS IN ORDINARY CHEMICAL REACTIONS<sup>1</sup>

BY J. HOWARD MATHEWS AND LEON H. DEWEY

From time to time for a number of years announcements have appeared stating the discovery of new "rays" having their origin in ordinary chemical reactions. In the attempt to prove the existence of such rays a great number of experiments have been made. Many reactions which were thought to have been productive of such rays have been proven to be ordinary chemical reactions, the gaseous products of which produced the supposed phenomena.

The latest addition to the literature on this subject appears in the form of an article by Matuschek and Ueming<sup>2</sup> in the *Chemiker Zeitung*. A brief résumé of their article is as follows:

A beaker containing zinc and hydrochloric acid was placed on a photographic plate in a light-tight case, a tin-foil star being interposed between the beaker and plate. After several hours of "exposure" a distinct image of the star was obtained upon development of the plate. The best results were said to have been found when ribbed (fluted) pieces of zinc were used. Similar results were obtained with hydrochloric and nitric acids acting on copper, tin and lead. The intensity of the new "rays" was found to vary considerably. Copper hydroxide, copper oxide, and potassium hydroxide also gave the photographically active "rays" when dissolved in acids. Other reactions producing the "rays" were: the slaking of lime, the setting of Portland cement, the decomposition of calcium by water and the formation of ammonium amalgam. The reaction producing the strongest "rays" was that between dilute hydrochloric acid and sodium silicate, which gave a distinct image in less than an hour's time.

<sup>1</sup> A paper read before the Eighth International Congress of Applied Chemistry in New York, September, 1912.

<sup>2</sup> *Chem. Zeit.*, 36, 21 (1912).

It was our object to verify, if possible, the results obtained by these investigators. A number of the above mentioned reactions—as many as the limited time allowed—were tried.

A light-tight wooden box, 18" × 12" × 12" in size, was lined with black paper and the edges padded with black cloth. The plates used were the well known Lumière Sigma plates, these particular plates being chosen because of their extreme sensitiveness. All the manipulations were carried out in a dark room, the plates being developed in darkness.

A plate was placed in the box and a beaker or Erlenmeyer flask containing the metal was placed upon it, a piece of tin-foil being interposed between the beaker (or flask) and the plate. The acid was introduced by means of a separatory funnel which passed out through a light-tight joint in the cover of the box. When a beaker was used the gaseous products of the reaction were not conducted away, but remained in the box where they could come into contact with the plate. When the Erlenmeyer flask was used, however, the gaseous products were conducted away through a delivery tube extending out of the box, so that by no possibility could the gases come into contact with the plate.

#### EXPERIMENT I

##### (a) Action of Dilute (1:3) Hydrochloric Acid on Zinc, in a Beaker

Here there was no attempt to conduct the gaseous products of the reaction away. Instead of interposing a tin-foil star between beaker and plate, a circular piece of foil, having a circular hole in the center, was used. The diameter of the piece of foil was slightly greater than the diameter of the beaker. After the reaction had been going for an hour or two the plate was removed and developed and an image of the piece of foil appeared, that portion of the plate protected by the foil not being reduced by the developer. However, not only was the plate unaffected beneath the foil but that portion under the hole in the center was also unaffected.

**(b) Action of Dilute Hydrochloric Acid on Zinc, in an Erlenmeyer Flask**

In this experiment the same reaction was repeated, but the hydrogen formed in the reaction was conducted away, and upon development the plate showed no sign whatever of reduction.

**(c) Plate Protected by Glass**

Experiment (a) was repeated, except that a clean sheet of glass the same size of the plate was placed upon the emulsion and the two plates securely fastened together with strips of adhesive cloth, making it impossible for gases to come into contact with the emulsion. The beaker was placed upon the plate, with the tin-foil interposed. After twenty-four hours' exposure to the reaction the plate showed no signs of reduction upon development.

**EXPERIMENT II**

(a) and (b) of Experiment I were repeated, using dilute nitric instead of hydrochloric acid. In both cases the results obtained were the same as in the previous experiment.

The fact that no reduction was apparent when the gaseous products of the reactions were conducted away led to the following experiment:

**EXPERIMENT III**

In this experiment the action of hydrogen gas on the photographic plate was tried. For this purpose an ordinary hydrogen generator was fitted up and the gas was allowed to impinge upon a photographic plate from a glass tube drawn out to a very fine jet. Upon development the plate was found to be reduced wherever the hydrogen had come into contact with it. Using the hydrogen jet for a pen one can write upon the plate by allowing the gas to impinge upon the plate, the writing remaining invisible until development has taken place.

From these experiments it seems certain that the effects noted by Matuschek and Ueming were due to the gaseous

products of the reactions employed. In our first experiment no image of the circular hole in the foil appeared because the pressure of the beaker prevented the gas from reaching this portion of the plate.

#### **EXPERIMENT IV**

In this experiment the action of dilute hydrochloric acid upon sodium silicate was tried. To 25 cc of a solution of sodium silicate contained in a small beaker standing on a plate dilute hydrochloric acid was added. No reduction of the plate could be detected after development, although the reaction was continued for a considerable time.

#### **EXPERIMENT V**

##### **(a) Water on Calcium Carbide, in a Beaker**

Upon exposure to this reaction for twenty-four hours the plate, where not protected by the foil, was plainly reduced.

##### **(b) Water upon Calcium Carbide, in a Flask**

The same reaction was repeated, but in this case the gaseous products of the reaction were carried away. The plate showed no reduction upon development.

#### **EXPERIMENT VI**

##### **The Setting of Portland Cement**

A sample of ordinary Portland cement was mixed with water and poured into a paste-board ring affixed to a glass plate. This plate was then laid upon a photographic plate in the dark and the cement allowed to set. Although the experiment was continued for forty-eight hours no indication of any reduction could be detected upon development. Had any gas capable of reducing the plate been given off during the process of setting, it could not have affected the plate because the emulsion was protected by the glass plate in contact with it.

#### **EXPERIMENT VII**

##### **The Slaking of Lime**

Lime was caused to slake slowly by the frequent addition of small amounts of water. The operation was conducted

in a beaker standing upon a photographic plate. After forty-eight hours the plate showed no indication of reduction upon development.

From the results of the foregoing experiments we are led to conclude that the reduction of photographic plates observed by Matuschek and Ueming was due, not to any new kind of "rays," but to the natural gaseous products of the reactions employed. This is substantiated by the fact that there was no reduction in any case where the gaseous products of the reaction were conducted away from the plate, and by the fact that when certain of the gaseous products (viz., hydrogen) were brought into contact with the plate a reduction resulted.

*University of Wisconsin*

## PRELIMINARY STUDIES ON DIRECT PHOTOGRAPHIC POSITIVES<sup>1</sup>

BY G. A. PERLEY AND ALAN LEIGHTON

During the experiment on solarization phenomena conducted by one of us<sup>2</sup> the reversal of the negative photographic image by thiocarbamides was considered.

Colonel Waterhouse<sup>3</sup> found that a positive image resulted in place of the normal negative during some experiments made early in July with an eikonogen developer to which a little phenylthiocarbamide had been added. He obtained more or less complete positive pictures not only with the phenyl compound, but also with allyl-thiocarbamide. Thiocarbamide yielded still less regular results, while urea failed to give any sort of a reversal.

The results obtained by Colonel Waterhouse left much to be desired in clearness.

After many trials during the first experiments on solarization a more or less satisfactory positive was obtained by adding a small amount of a thiocarbamide to a hydroquinone developer. The work was conducted during the warm summer months.

By means of a preliminary immersion of the plates in the thiocarbamide solution, and washing in running water for a short time, fairly consistent positives were obtained for exposures a little below the normal. Such results seemed to warrant a theory of sensitizing action.

As the previous work had not created a really practical method for the production of direct positives, it seemed advisable to clear up the weak points. It was evident that a detailed study of conditions was essential for a clear understanding of the process.

<sup>1</sup> A paper read before the Eighth International Congress of Applied Chemistry in New York, September, 1912.

<sup>2</sup> Perley: *Jour. Phys. Chem.*, 13, 630 (1909).

<sup>3</sup> Waterhouse: *Proc. Asiatic Soc. of Bengal*, Aug., 1890.

At first a developer of the following composition was made:

Solution A	Solution B
1,000 grams water 126 grams Na <sub>2</sub> SO <sub>3</sub> (anhyd.) 21 grams hydroquinone	1,000 grams water 126 grams Na <sub>2</sub> CO <sub>3</sub> (anhyd.)

The thiocarbamide was made according to the method of Reynolds.<sup>1</sup> Ammonium thiocyanate was heated in a round-bottom flask at a temperature of 140° to 180° C for five hours. The remaining thiocyanate was extracted with cold water. The thiocarbamide was dissolved in hot water, evaporated and recrystallized. A standard solution of 1 gram of thiocarbamide in one liter of water was employed.

In the early spring work was undertaken to duplicate former results. The developer consisted of 20 cc of the thiocarbamide solution, 25 cc of Solution A, and 25 cc of Solution B.

A positive of a brownish purple color was obtained on plates exposed under a standard lantern-slide plate. In many cases only a partial reversal resulted.

Much time was expended in varying the different constituents of the developer until a fairly satisfactory positive was obtained. These results are of no importance in the light of our recent work and accordingly may be omitted.

Just as the results seemed to be capable of duplication the warm spring days approached. With this balmy weather some sort of a spring ailment afflicted the developer. None of the much prized previous results could be duplicated.

The first explanation was that of depreciation of the thiocarbamide solution. The solution of thiocarbamide was titrated from day to day with standard permanganate, and the solution was found to remain quite stable. Newly prepared solutions failed to eliminate the trouble.

In order to ventilate the dark room properly during the

<sup>1</sup> Reynolds: Jour. Chem. Soc., 22, 1 (1869).



warmer weather it was necessary to open the windows. At this point it became possible to produce positives of fair quality. The solution of our former troubles became clear. The reactions were exceedingly affected by temperature changes.

As the previous data seemed to be worthless in the light of this last fortunate discovery, and as the reactions involved seemed to attain almost a quantitative aspect, a new source of attack was formulated.

Every variable involved was placed under quantitative control. Separate standard solutions of each of the constituents of the developer were made, and all other factors were standardized.

The 5 × 7 camera employed was made by the Eastman Kodak Co. and equipped with a Cooke anastigmat lens, Series III f/6.5, made by Bausch & Lomb.

A standard photograph was located 19 inches from the lens of the camera and illuminated by means of a Cooper-Hewitt mercury arc lamp whose center was 22 inches above the photograph. All photographs were taken with the widest stop (f/6.5).

The following standard solutions were employed:

Thiocarbamide,	1 gram per liter
Hydroquinone,	21 grams per liter
Na <sub>2</sub> CO <sub>3</sub> (anhyd.),	126 grams per liter
Na <sub>2</sub> SO <sub>3</sub> (anhyd.),	126 grams per liter

Each of these solutions was measured from a standard burette. A burette stand was located in the dark room in such a manner that the four burettes were compact, yet easily accessible. The water was measured by means of a pipette.

Considering that the source of illumination and actinic value of the light was maintained constant by the above precautions, and that a plate of the same emulsion was employed, we recognized the following variables: time of exposure, temperature of development, time of development, size of plate, amount of thiocarbamide, hydroquinone, sodium carbonate, sodium sulphite and water. A total of

nine variables had to be considered before the perfect conditions could be understood.

The plates employed in this work were purchased at different times, but the Seed 26 X plate was always used.

Each one of the constituents was measured into a glass tray and the whole developer was thoroughly mixed before immersing the plate. The developer was used for one experiment and then discarded.

Using the concentrations that had previously given the best results the data of Table I were obtained:

TABLE I

Size of plate  $6\frac{2}{3}$  sq. in.

Exposure in seconds, 8.

Time of development, 5 minutes.

Composition of developer: 0.020 gram thiocarbamide; 0.273 grams hydroquinone; 1.512 grams  $\text{Na}_2\text{SO}_3$ ; 0.504 gram  $\text{Na}_2\text{CO}_3$ ; 85 grams  $\text{H}_2\text{O}$ .

No.	Temperature of developer	Remarks
1	8° C	Thin negative
2	10° C	Thin negative
3	12° C	Best positive
4	14° C	Fogged positive
5	16° C	Heavy fog
6	18° C	Heavy fog

The results of Table I show that only one temperature can be employed for the particular concentration of developer used. The temperature was controlled by inserting the tray of previously cooled developer into a mixture of ice and water maintained at the desired temperature.

A difference of two degrees Centigrade from the best conditions yielded an absolutely worthless plate.

The influence of temperature on this reaction is enormous. This undoubtedly explains the reason for the better success attained previously by a preliminary immersion in running water. During the hot months this served to cool the developer to the essential temperature conditions.

In view of these data all future work was conducted at 12° C during development.

The results of Table II were obtained by varying the content of thiocarbamide.

TABLE II

Size of plate, 6<sup>2</sup>/<sub>3</sub> sq. in.  
 Exposure in seconds, 8.  
 Temperature of developer, 12° C.  
 Time of development, 5 minutes.  
 Composition of developer: 0.273 gram hydroquinone; 1.512 grams Na<sub>2</sub>SO<sub>3</sub>; 0.504 gram Na<sub>2</sub>CO<sub>3</sub>; 85 grams H<sub>2</sub>O.

No.	Gram thiocarbamide	Remarks
1	0.006	Thin negative
2	0.008	{ Partial positive; high lights negative
3	0.010	{ Partial positive: high lights negative
4	0.014	Fogged positive
5	0.018	Heavy fog
6	0.020	Best positive
7	0.022	Thin positive
8	0.024	Thin positive
9	0.026	Thin positive
10	0.030	Thin positive
11	0.032	Thin positive
12	0.034	Thin positive
13	0.036	Thin positive
14	0.040	No image

It was evident that at 12° C the best amount of thiocarbamide was 0.02 grams when used with 85 grams of water, 0.273 gram hydroquinone, 1.512 grams Na<sub>2</sub>SO<sub>3</sub>, and 0.504 gram Na<sub>2</sub>CO<sub>3</sub>. This, of course, is not essentially the best developer.

This work brought forth a few interesting points. Only a very small amount of thiocarbamide (0.003 gram per sq. in. of plate surface) is required to produce a positive. Its action with high concentrations is limited by the influence it has as a solvent for the emulsion. In other words, a partial positive results with insufficient thiocarbamide; with a trifle

in excess, the reaction is so rapid that a badly fogged plate results; and with still greater amounts, a thin positive with less fog is produced. Above a certain concentration there is only a solvent action.

It was interesting to note that for the lower concentrations a fairly dense reddish brown deposit was produced, while just beyond the zone of complete fogging (0.02 gram) a brownish purple deposit made up the positive image. The two colors were absolutely different.

The next variable studied was the hydroquinone and the data are given in Table III.

TABLE III

Size of plate,  $6\frac{2}{3}$  sq. in.  
 Exposure in seconds, 8.  
 Temperature of developer,  $12^{\circ}$  C.  
 Time of development, 5 minutes.  
 Composition of developer: 0.020 gram thiocarbamide; 1.512 grams  $\text{Na}_2\text{SO}_3$ ; 0.504 gram  $\text{Na}_2\text{CO}_3$ ; 85 grams  $\text{H}_2\text{O}$ .

No.	Grams hydroquinone	Remarks
1	0.126	Heavy fog
2	0.184	Heavy fog
3	0.210	Heavy fog
4	0.252	Best positive
5	0.273	More dense positive
6	0.294	Thin positive
7	0.336	Thin positive
8	0.357	Partial negative
9	0.420	Partial negative

Table III shows that there is only a comparatively narrow range for the variation of hydroquinone within which good results may be produced.

The action may be best understood by a description of the progress of development. In all cases where a more or less good positive results there first appears a very faint negative on the plate. This develops as a rule after one and a half minutes' immersion; after approximately three minutes, the negative appears to fade into a positive which attains its

best contrasts after a total of five minutes' development. The production is a very thin negative, and seems to be essential to the making of a good positive.

The rôle of the hydroquinone would seem to be in the production of just the minimum negative to render a positive. Too small amounts would not yield a negative. Hence, there would be a uniform development over the whole surface. This explains the fog. Too large amounts would yield such a dense negative (provided the exposure was sufficient) that it would injure the positive effect.

The very thin negative that seemed essential for the success of the positive creates a thin fog in the high lights of the very best positives.

The amount of sodium carbonate was next varied and the results are given in Table IV.

TABLE IV

Size of plate,  $6\frac{2}{3}$  sq. in.  
 Exposure in seconds, 8.  
 Temperature of developer, 12° C.  
 Time of development, 5 minutes.  
 Composition of developer: 0.020 gram thiocarhamide; 0.252 gram hydroquinone; 1.512 grams  $\text{Na}_2\text{SO}_3$ ; 85 grams  $\text{H}_2\text{O}$ .

No.	Grams $\text{Na}_2\text{CO}_3$	Remarks
1	0	Blank
2	0.126	Very thin negative
3	0.252	Thin negative
4	0.378	Best positive
5	0.504	Fair positive
6	0.630	Very fair positive
7	0.756	{ Dense positive; high lights negative
8	0.882	{ Dense positive; high lights negative
9	1.134	{ Dense positive; high lights negative
10	1.386	Dense partial negative
11	1.764	Dense partial negative

Table IV gave results consistent with Table III. With increase of carbonate there is of course an increase in the

density of the negative produced per unit time. For excessive amounts of carbonate there would then be a negative masking a positive. The data show one interesting point. There is, off hand, no reason why No. 2 should not have produced the best positive, as the thinnest negative (with no trace of a positive) resulted with this concentration. This result would seem to indicate that a certain amount of carbonate is essential in the production of a positive.

The sodium sulphite was next varied and the results are given in Table V.

TABLE V

Size of plate,  $6\frac{2}{3}$  sq. in.  
 Exposure in seconds, 8.  
 Temperature of developer,  $12^{\circ}$  C.  
 Time of development, 5 minutes.  
 Composition of developer: 0.020 gram thiocarbamide; 0.252 gram hydroquinone; 0.378 gram  $\text{Na}_2\text{CO}_3$ ; 85 grams  $\text{H}_2\text{O}$ .

No.	Grams $\text{Na}_2\text{SO}_3$	Remarks
1	0	Fogged negative
2	0.378	{ Partial positive; high lights negative
3	0.630	{ Partial positive; high lights negative
4	1.008	Fair positive
5	1.260	More dense positive
6	1.386	Dense positive
7	1.512	Very dense positive
8	1.638	Less dense positive
9	1.890	Best positive
10	2.520	Less dense positive
11	2.772	Thin positive

With increase of sulphite there seems to be a maximum in the density of the positive. An increase in concentration of sulphite limits the quality of the positive by a seemingly restraining or solvent action. Since the density of the positive passes through a maximum, it is possible to obtain good results with two different concentrations of sulphite (1.008 grams and 1.890 grams), yet 1.890 grams is the preferable since there is a minimum of darkening in the high lights. The

data of No. 1 show that a certain amount of sulphite is necessary for the production of a positive.

The results of Tables I, II, III, IV and V indicated that with an exposure of 8 sec., and a development to 12° C, a developer for a plate with 6<sup>2</sup>/<sub>3</sub> sq. in. of surface area consisting of 0.02 gram thiocarbamide, 0.252 gram hydroquinone, 0.378 gram sodium carbonate, and 1.890 grams sodium sulphite in 85 grams of water was the best. At any rate, consistent results could be obtained.

There are a few criticisms on the positive produced, even under the most ideal conditions. First, each plate has a thin light brown fog just beneath its surface. The fog does not appear in the slightest by transmitted light, yet upon reflected light it becomes very evident. This only detracts from the appearance of the plate and not from its use. Secondly, the production of a good positive requires a thin, yet distinct negative. The reduced silver yields in the high lights a very thin fog, while the shadows overmask the negative by the dense positive deposit. The negative is so thin that it does not appear when the plate is used as a lantern slide. Thirdly, the deposits do not have the characteristic black color, but are nearly purple. It is an interesting fact that, after fixing and washing, the deposit is of a beautiful sepia tone, while after drying it has a purple hue.

Since the attempt to eliminate the negative by variation of carbonate or hydroquinone was a failure, the time of exposure was varied as a last resort. The results as given in Table VI were obtained.

Table VI shows that with too great an exposure the negative develops more rapidly than the positive. For too short exposures there seems to be a uniform surface development. For exposures below six seconds there seems to be an insufficient latent image formed to facilitate the development of a contrasting and dense positive. Thus the data of Table VI are consistent with those of Tables III and IV.

TABLE VI

Size of plate,  $6\frac{2}{3}$  sq. in.Temperature of developer,  $12^{\circ}$  C.

Time of development, 5 minutes.

Composition of developer: 0.020 gram thiocarbamide; 0.252 gram hydroquinone; 1.890 grams  $\text{Na}_2\text{SO}_3$ ; 0.378 gram  $\text{Na}_2\text{CO}_3$ ; 85 grams  $\text{H}_2\text{O}$ .

No.	Exposure in seconds	Remarks
1	2	Thinly fogged positive
2	3	Thinly fogged positive
3	4	More dense positive
4	5	Fair positive
5	6	Good positive
6	7	Best positive
7	8	Fair positive
8	9	Fair positive
9	10	Partial negative
10	11	Nearly all negative
11	13	Negative

All of the variables had been considered with the exception of the water content. Table I gave indications that there might be a possibility of varying the total concentration of the active agent and thereby to alter the rate of reaction. The results of this work are given in Table VII.

TABLE VII

Size of plate,  $6\frac{2}{3}$  sq. in.

Exposure in seconds, 8.

Temperature of development,  $12^{\circ}$  C.

Time of development, 5 minutes.

Composition of developer: 0.020 gram thiocarbamide; 0.252 gram hydroquinone; 1.890 grams  $\text{Na}_2\text{SO}_3$ ; 0.378 gram  $\text{Na}_2\text{CO}_3$ .

No.	Grams $\text{H}_2\text{O}$	Remarks
1	51	Thin negative
2	68	Thin negative
3	77	Thin negative
4	81	Fair positive
5	85	Best positive
6	81.5	Thinner positive
7	91	Heavily fogged positive
8	101	Fog



Table VII shows that only within a narrow range of total concentration can any sort of a positive result. With a high concentration the latent image is developed the more rapidly and the thiocarbamide exerts a solvent action. With greater dilution, the rate of development of the whole surface becomes uniform with the resultant formation of a fog.

In order to obtain a qualitative idea concerning the effect of plate surface on the process, an exposed plate of the normal size was developed under the best conditions. A second exposed plate was immersed in the same developer. A very badly fogged positive resulted. It thus seemed essential to express the concentration of the developer in plate surface units.

Table VII indicated a method of applying the process at room temperature and accordingly the results of Table VIII were obtained.

TABLE VIII

Size of plate,  $6\frac{2}{3}$  sq. in.  
 Exposure in seconds, 6.  
 Temperature of developer, 18°.  
 Time of development, 5 minutes.  
 Composition of developer: 0.020 gram thiocarbamide; 0.252 gram hydroquinone; 1.890 grams  $\text{Na}_2\text{SO}_3$ ; 0.378 gram  $\text{Na}_2\text{CO}_3$ .

No.	Grams $\text{H}_2\text{O}$	Remarks
1	41	Very thin positive
2	51	Best positive
3	56	Dense and fogged positive
4	61	Fog

The work showed that it is possible to obtain a positive at room temperature, yet the water content must be regulated with great care.

During the work at 12° C a universal thin haze seemed to appear on all of the plates with the exception of one box. One box of the Seed 26 X plates gave a very sharp contrasting positive. At the time, this was considered purely a manipulative error. At 18° C this haze increased slightly in density.

In order to check up the influence of the emulsion on our results a  $3\frac{1}{4} \times 4$  lantern slide plate made by the Imperial Dry Plate Co. was exposed under the same conditions as in the previous work. The developer consisted of 0.0030 gram thiocarbamide, 0.0387 gram hydroquinone, 0.2907 gram  $\text{Na}_2\text{SO}_3$ , 0.0775 gram  $\text{Na}_2\text{CO}_3$ , and 7.8461 grams  $\text{H}_2\text{O}$  per square inch of plate surface. An exceedingly fine positive resulted, yet with the characteristic minor faults. With a Seed 26 X plate of the same size and developed under the same conditions the thin fog was visible. Thus, much depends on the emulsion when perfect results are sought.

This work must be considered as a preliminary study of the process. All indications point to the possibility of producing a direct positive of fine quality.

Experiments are already proceeding with a view to substituting such developing agents as pyrogallol, eikonogen, metol, glycine, pyrocatechin, amidol, rodinal, etc., for the hydroquinone.

The results, to date, indicate that the reducing agent affects the color of the resulting deposit. Eikonogen was found to yield far less fog, no visible negative after fixing, and almost a black deposit. The results on this are very incomplete.

There is also the possibility of substituting allyl thiocarbamide, phenyl thiocarbamide, and, in fact, all of the thiocarbamides in place of straight thiocarbamide. The results will be greatly different from our present series. A small amount of work on the allyl thiocarbamide has shown possibilities. In place of the purple deposit consistently obtained by use of thiocarbamide, a most beautiful red deposit results. If it were not for the reddish fog, the present results would yield a plate almost unequalled by hand painting for use as a transparency. The results on this are incomplete.

A later paper on the theory of this process will attempt to clear the problem. Instead of using some thiocarbamide or derivative it should be possible to find some substance that will eliminate the present unpleasant fog.

Other possible sources of attack are in the addition of

some type of a restrainer which will restrain the negative and leave the positive unaffected. A small amount of potassium bromide was found to restrain the positive more rapidly than the negative. As yet some chloride, citric acid, etc., have not been tried as restrainers.

If the present thin negative and brownish fog formation can be restrained, a perfect plate may be produced at room temperature.

The work is still under investigation.

To summarize:

1. The work was attempted in order to produce consistently direct positives of good quality.
2. The production of a positive by the Waterhouse process is most easily influenced by alteration of the conditions governing the reaction.
3. The variables considered in this preliminary study were: time of exposure, temperature of development, time of development, size of plate, amount of thiocarbamide, amount of hydroquinone, amount of sodium carbonate, amount of sodium sulphite and amount of water. Under the conditions the same emulsion was employed and the source of illumination and actinic value of the light was maintained constant.
4. The temperature during development must be carefully regulated. Utilizing a given concentration, the temperature cannot be varied more than one degree centigrade.
5. The quantity of the developer utilized governs the resultant positive. It is best expressed in plate surface units.
6. By exposing a plate in a camera to an object illuminated by a Cooper-Hewitt mercury arc light at a given distance, a positive was obtained after 5 minutes' development in the following solution maintained at 12° C: 0.0030 gram thiocarbamide, 0.0378 gram hydroquinone, 0.2837 gram Na<sub>2</sub>SO<sub>3</sub>, 0.0567 gram Na<sub>2</sub>CO<sub>3</sub> and 12.7627 grams water per square inch of plate surface.
7. An excess of any constituent which favors an increase in the development of the latent image yields a partial nega-

tive (or a masked positive). An insufficient amount produces uniform development and a resultant fog.

8. An excess of thiocarbamide acts as a solvent for the emulsion. An insufficiency does not visibly affect the thin negative resulting from normal development.

9. No single constituent can be omitted from the above developer to obtain good results.

10. At 12° C a small quantity of water (high concentration) causes the thiocarbamide to exert its solvent action. A large quantity of water (low concentration) retards the development of the latent image with the production of a fog.

11. Under the same conditions as in 6, at 18° C, an exceedingly good positive can be obtained on a lantern slide plate with 0.0030 gram thiocarbamide, 0.0387 gram hydroquinone, 0.2907 gram  $\text{Na}_2\text{SO}_3$ , 0.075 gram  $\text{Na}_2\text{CO}_3$ , and 7.8461 grams water per square inch of plate surface.

12. Work is being conducted on the substitution of eikonogen, metol, pyrogallol, amidol, glycine, rodinal, pyrocatechin, etc., for hydroquinone. Allyl thiocarbamide produces red deposits, while thiocarbamide yields bluish tones. The derivatives are under investigation.

13. A suitable restrainer for the yellow fog and thin negative would yield great improvements.

14. The contrast and clearness of the final deposit depend much upon the emulsion on the plate.

15. The only sources of dissatisfaction with the present positive are: first, the bluish color of the deposit; secondly, the necessity of a preliminary appearance of a thin negative; thirdly, the appearance by reflected light of a yellowish fog.

*New Hampshire College  
Durham, N. H.*

## A SIMPLE INEXPENSIVE CALORIMETER FOR DETERMINING THE HEAT OF SOLUTION AND OF NEUTRALIZATION

BY ERNEST ANDERSON AND H. A. NOYES

The apparatus consists of a wide-mouth Dewar bulb of about 450 cc capacity.<sup>1</sup> This is closed by a rubber stopper with two holes. Through one hole passes a Beckmann thermometer, and through the other, as an inlet to the stirrer, passes a glass tube three inches long, extending just inside the stopper. Both the thermometer and the tube should fit tightly. The stirrer is a glass spatula, with a blade approximately two inches long and one-half inch wide, to the handle of which is sealed a glass rod twelve inches long. The shaft of the stirrer is passed through the glass tube in the stopper which acts as one bearing. Then a small wooden pulley is fastened on the shaft, and above the pulley a second piece of glass tubing as a second bearing for the shaft. The apparatus is fastened to an iron ring stand and driven by a water or an electric motor (Fig. 1).

To determine the water equivalent of the calorimeter, 200 cc of water at about 8° above the room temperature is put in

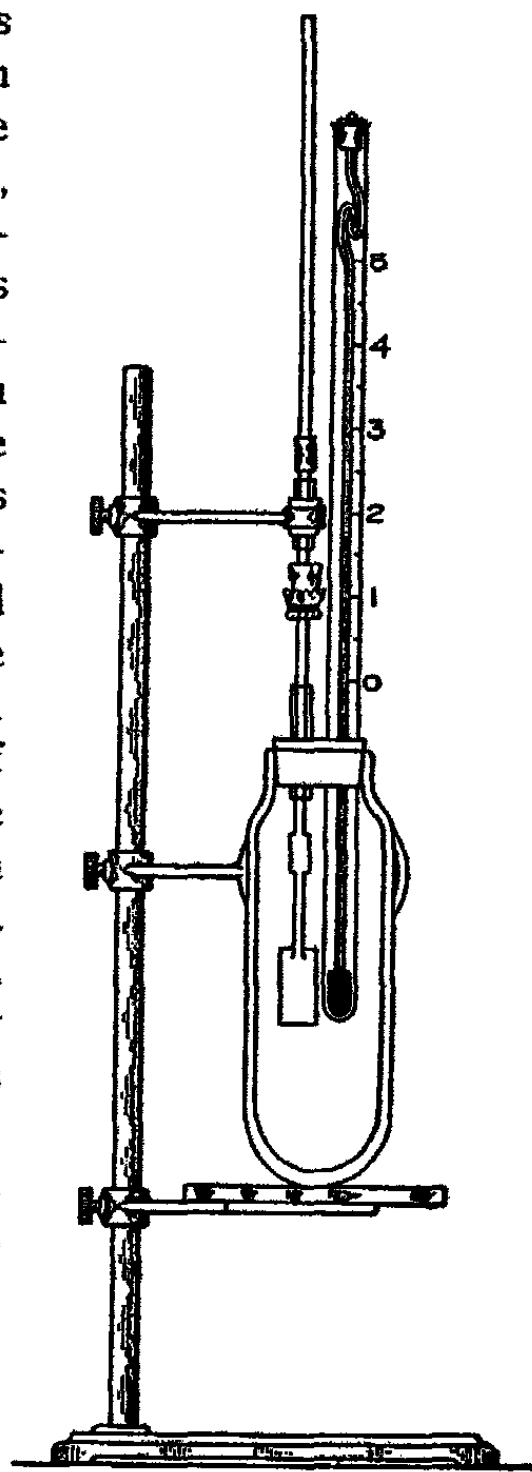

Fig. 1

<sup>1</sup> We used a *wide-mouth* "Thermos" bottle with aluminium case.

the calorimeter. The stirrer is started and the Beckmann thermometer is read each minute. As soon as the drop in temperature becomes constant, the temperature is read and 200 cc of water at room temperature is quickly poured into the calorimeter. The temperature of this water must be read on a Beckmann thermometer which has been compared with the one in the calorimeter. The water is stirred vigorously and the temperature drops in two minutes to its lowest point, and then begins to fall very slowly. If  $a$  and  $b$  are the weights of the hot and the cold water, these can be obtained from the temperature and the volume— $c$  and  $d$  the changes in the temperature of the hot and the cold water and  $x$  the water equivalent of the calorimeter; we have

$$(a + x)c = bd, \text{ or } x = \frac{bd}{c} - a.$$

To determine the heats of solution and of neutralization, the directions of any standard text on physical chemistry are used.

The following table contains a list of the values obtained with the calorimeter, no special precautions or corrections being observed:

	1	2	3	Av.	Usual value
Water equivalent	12.4 gs.	10.7 gs.	11.6 gs.	11.5 gs.	
Heat of solution of $\text{KNO}_3$	-8300	-8290	-8320	-8303	-8500
Heat of solution of $\text{NH}_4\text{Cl}$		-3877	-3843	-3860	-3880
Heat of neut. of $\text{Ba}(\text{OH})_2$ by $\text{HCl}$	13,977	13,984	13,932	13,964	+13,850

When the calorimeter contains 400 cc of water at room temperature and the stirrer is running vigorously, there is a rise in temperature of less than  $0.001^\circ$  per minute. When the temperature of the water is  $9^\circ$  above or below room temperature the loss or gain in temperature is  $0.01^\circ$  per minute.

The accuracy of the calorimeter could be increased by using the larger size Dewar bulb or quart "Thermos" bottle and by converting it into an adiabatic calorimeter according to the method of Richards.<sup>1</sup>

The calorimeter has given satisfaction in the hands of students, the purpose for which it was designed.

*Department of Chemistry  
Massachusetts Agricultural College*

---

<sup>1</sup> Jour. Am. Chem. Soc., 32, 272-274 (1910).

## THE VALENCE OF CHLORINE AS DETERMINED FROM THE MOLECULAR COHESION OF CHLORINE COMPOUNDS

BY ALBERT P. MATHEWS

Since molecular cohesion is a function of the molecular weight and the number of valences in the molecule,<sup>1</sup> we may use the cohesion for the purpose of determining the valence of elements; and in this paper I shall consider chlorine, although something will be said, also, about the other halogens.

It is generally believed, at the present time, that the valence of chlorine is not fixed, but varies in different compounds from one to seven. In its organic, and some inorganic compounds, and in its elemental form it is generally represented as univalent; whereas in the chlorates it is supposed to be pentavalent; and in the perchlorates it is heptavalent.

That chlorine even in such compounds as chloroform, where it replaces univalent hydrogen, may not be univalent is indicated by the action of chlorine compounds on light. Drude,<sup>2</sup> reasoning that it must be the valence electrons of compounds which would have a period of vibration sufficiently long to respond to light waves, worked out a modification of the Ketteler-Helmholtz dispersion formula which enabled an approximate computation of the number of electrons influencing dispersion in the molecule. He found that in many cases this number was close to the total number of valences in the molecule; but in the case of compounds containing chlorine and fluorine, the number of such light-refracting valences was always greater than in the corresponding hydrogen compounds, and he inferred from this that

<sup>1</sup> Mathews: "The Relation of the Constant "a" of van der Waals' Equation to the Molecular Weight and the Number of Valences in the Molecule," *Jour. Phys. Chem.*, 17, 181 (1913).

<sup>2</sup> Drude: "Optische Eigenschaften und Elektronen Theorie," *Annalen der Physik*, [4], 14, 677 (1904).



these elements must be polyvalent, and not monovalent, as they were usually supposed to be. This conclusion of Drude's was confirmed by Pascal<sup>1</sup> both by the dispersion method of computing valence and by a study of the diamagnetic properties of halogen compounds, the diamagnetic properties having been shown to be related to the number of valences in the molecule. Pascal concluded that fluorine, in organic compounds at any rate, was univalent; but chlorine and the other halogens were polyvalent, and probably chlorine was trivalent. Traube,<sup>2</sup> in a study of the relationship between the molecular refraction of compounds and the number of their valences, found that for most compounds the molecular refraction of Brühl divided by the number of valences in the molecule was a constant, or nearly such, in all saturated compounds; but in the case of molecules containing the halogens it was necessary to ascribe several valences to the halogens to obtain this constant. He attributed seven valences to chlorine, and had to make still other assumptions for bromine and iodine to bring them into line.

Several chemists, also, have in the past ascribed several valences to chlorine. Thus Meldola<sup>3</sup> wrote the formula of

methylether hydrochloride, in the form  $\begin{array}{c} \text{CH}_3 \\ \text{CH}_3 \end{array} \rangle \text{O} = \text{Cl}-\text{H}$ ,

with chlorine trivalent; Nef<sup>4</sup> represented elemental chlorine as trivalent, but combined chlorine generally as monovalent; and recently Thiele<sup>5</sup> has especially emphasized the reserve, or extra, valences of iodine and bromine, although, as a rule, he represents chlorine as univalent. Even in sodium chloride it is not certain that the chlorine is univalent, since it is

<sup>1</sup> Pascal: "Recherches magnéto-chimiques sur la structure atomique des halogènes," *Comptes rendus*, 152, 862 (1911); "Sur un mode de contrôle optique des analyses magnéto-chimiques," *Ibid.*, 152, 1852 (1911).

<sup>2</sup> Traube: "Valency, Lichtbrechung u. volume," *Ber. chem. Ges. Berlin*, 40, 130 (1907).

<sup>3</sup> Meldola: I have mislaid this reference and have not been able to find it again.

<sup>4</sup> Nef: *Liebig's Ann.*, 298, 205 (1897).

<sup>5</sup> Thiele and Peter: *Ber. chem. Ges. Berlin*, 38, 2842 (1905).

known that sodium chloride will add iodine, presumably by the extra valences of the chlorine.<sup>1</sup>

There is good ground, therefore, for doubting whether chlorine is ever monovalent. This question can be tested easily by the cohesion method.

Before proceeding to the actual computations it must be decided whether the cohesion method detects only valences actually employed in binding atoms together, or stretching between the atoms; or whether it detects in addition the reserve valences; and also valences which do not extend to atoms, but which are open, in an active form, and ready to combine if the opportunity arises. It is clear from my former paper that concealed, polarized, resting or reserved valences do not play any part in cohesion; or, at any rate, they are not to be counted in the number of valences affecting the cohesion. Thus oxygen has certainly two reserve valences which are usually in an inactive or resting state. In many compounds examined, not more than two valences could be attributed to the oxygen as affecting its cohesion. These two reserve valences played no rôle as long as they were inactive. Similarly, nitrogen has the power of opening up at least seven valences, but it was actually found that only one, two or three valences played a rôle in the cohesion of the nitrogen compounds, depending on how many active valences the atom had. The reserve, or inactive, valences played no part. Carbon is usually quadrivalent, but it is suspected of having the power of becoming hexavalent; but the number of valences active in carbon compounds was always two, or four. If these reserve valences of carbon exist they do not affect cohesion. Sulphur, too, although it may be hexavalent, has only four of its valences playing a part in the cohesion of sulphur dioxide; the two reserve valences are inactive on the cohesion.

It is clear, then, that the cohesion does not detect, and consequently it is not affected by, those reserve valences which are polarized, or resting, or, which are, as it were, like antennae, withdrawn or folded, within the atom.

<sup>1</sup> See Friend: "The Theory of Valency," London, 1909, pp. 58 et seq.

But valences may conceivably exist in an active state not stretching between atoms, but extending outward from the atom and in a condition to unite with other atoms. These are active valences. For example, we may expect the valences on the atoms of a dissociated, monovalent gas to be in this condition. Such atoms would naturally be very active chemically and we should expect the cohesion of such particles to be affected by this condition. There are many evidences that this is actually the case and that valences of this kind are detected by cohesion and will be included in the number of valences computed from the cohesion as existing in the molecule. This is well shown in the argon group, which I shall discuss later, in which it appears that there are two such active valences in argon, krypton, and probably xenon. It appears to be the case, too, in unoxidized sulphur compounds such as ethyl sulphide, as I shall show in a subsequent paper. And there is evidence elsewhere that these open or active valences affect cohesion, although they do not stretch between the atoms of the same molecule. It is, then, active valences, and valences actually employed in binding together the atoms of the molecule, which affect molecular cohesion. It is only the number of such valences which the cohesion enables us to compute, and it is, of course, exactly for this reason that the method has so great a value.

We may then be certain that if we find the valence of chlorine to be three and the compounds are not associating, those three valences are not free, but are actually extending between atoms in the molecule, and if we wish an accurate graphic formula of the compound we must represent these ties.

The method of measuring the number of valences is to compute the number from "*a*" of van der Waals' equation, or from what I have called the square of the cohesive mass, or  $M^2K$ , a factor which is equal to "*a*", divided by the square of the number of molecules in the volume of fluid for which "*a*" has been taken. The method of computing  $M^2K$  is given in the previous paper. The formula employed is  $M^2K = 2.98 \times 10^{-37} (\text{Mol. Wt.} \times \text{Valences})^{2/3}$ . Or: Number of Valences =  $(M^2K)^{3/2} \times 6.147 \times 10^{34} / (\text{Mol. Wt.})$ .

TABLE I.—THEORETICAL AND COMPUTED NUMBER OF VALENCES IN CHLORINE COMPOUNDS

1 Substance	2 Formula	3 Log <sub>10</sub> M <sup>w</sup> K	4 Mol. wt.	5 Computed No. of valences	Theoretical No. of valences		8 Graphic formula
					6 Cl=3	7 Cl=1	
1 Carbon tetrachloride	CCl <sub>4</sub>	-35.74247	153.8	16.4	16	8	
2 Stannic chloride	SnCl <sub>4</sub>	-35.87500	260.8	15.3	16	8	
3 Germanium tetrachloride	GeCl <sub>4</sub>	-35.79817	214.3	14.3	16	8	
4 Chlorobenzene	C <sub>6</sub> H <sub>5</sub> Cl	-35.84615	112.45	32.1	32	30	
5 Chloroform	CHCl <sub>3</sub>	-35.61128	119.35	13.5	14	8	
6 Methyl chloride	CH <sub>3</sub> Cl	-35.26811	50.45	9.7	10	8	

TABLE I (Continued)

7	Propyl chloride	$C_3H_7Cl$	-35.59465	78.45	19.7	22	20	
8	Ethyl chloride	$C_2H_5Cl$	-35.49356	64.45	16.6	16	14	
9	Ethylidene chloride	$C_2H_4Cl_2$	-35.63725	98.9	17.8	18	14	
10	Ethylene chloride	$C_2H_2Cl_2$	-35.67488	98.9	20.2	18	14	
11	Chlorine	$Cl_2$	-35.22351	70.9	5.9	6	2	$Cl \equiv Cl$
12	*Silicon tetrachloride	$SiCl_4$	-35.74648	170.2	15.1	16	8	
13	*Thiosulphuryl chloride	$S_2Cl_2$	-35.76597	134.9	20.3	18	14	Some association. S=6
14	*Acetyl chloride	$CH_3COCl$	-35.55497	78.45	16.8	16	14	
15	*Chlorethyl formate	$C_2H_5ClO_2$	-35.74968	108.45	23.9	24	22	
16	*Chloral	$CCl_3CHO$	-35.73899	147.35	16.9	20	14	
17	*Thionyl chloride	$SOCl_2$	-35.63703	118.9	14.8	14	10	
18	*Sulphuryl chloride	$SO_2Cl_2$	-35.65648	134.9	14.1	14	10	
19	*Phosphorus trichloride	$PCl_3$	-35.70915	137.35	16.4	16	10	P = 7
20	*Phosphorus oxychloride	$POCl_3$	-35.76967	153.35	18.1	18	12	P = 7
21	Hydrochloric acid	HCl	-35.88550	36.45	3.6	4	2	Associates
22	Bromine	$Br_2$	-35.14659	159.92	2.0	6	2	Br-Br
23	Brombenzene	$C_6H_5Br$	-35.89265	157	27.0	32	30	
24	Iodobenzene	$C_6H_5I$	-35.96071	204	26.4	32	30	
25	*Ethyl iodide	$C_2H_5I$	-35.67614	155.85	12.9	16	14	

\*Compounds marked \* have  $V_c$  and  $T_c$  computed from the surface tension, and  $M^*K$  is not so accurate as when  $V_c$  and  $T_c$  are directly determined. For the method of computation see the preceding paper.

To show how closely these compounds yield the constant "c," where  $c = M^2K/(\text{Mol. Wt.} \times \text{Valences})^{2/3}$ , Table II is appended. "C" was found in a previous paper to be about  $2.98 \times 10^{-27}$  for other than chlorine compounds. Chlorine is throughout considered as trivalent.

TABLE II.—"C" CALCULATED FOR CHLORINE COMPOUNDS. CL CONSIDERED TRIVALENT EXCEPT IN HYDROCHLORIC ACID AND PROPYL CHLORIDE

	Substance	Formula	Val- lance	$C \times 10^{27}$	Remarks
1	Carbon tetrachloride	$\text{CCl}_4$	16	3.03	
2	Stannic tetrachloride	$\text{SnCl}_4$	16	2.91	
3	Germanium tetrachloride	$\text{GeCl}_4$	16	2.78	All 4 chlorines trivalent
4	Silicon tetrachloride	$\text{SiCl}_4$	16	2.86	
5	Chloroform	$\text{CHCl}_3$	14	2.90	
6	Methyl chloride	$\text{CH}_3\text{Cl}$	10	2.97	
7	Chlorine	$\text{Cl}_2$	6	2.96	
8	Ethyl chloride	$\text{C}_2\text{H}_5\text{Cl}$	16	3.06	
9	Ethylene chloride	$\text{C}_2\text{H}_4\text{Cl}_2$	18	3.15	
10	Ethylidene chloride	$\text{C}_2\text{H}_3\text{Cl}_2$	18	3.02	
11	Chlorobenzene	$\text{C}_6\text{H}_5\text{Cl}$	32	2.98	
12	Thiosulfuryl chloride	$\text{S}_2\text{Cl}_2$	18	3.23	Some association
13	Acetyl chloride	$\text{CH}_3\text{COCl}$	16	3.08	Slight association
14	Chlorethyl formate	$\text{C}_2\text{H}_5\text{ClO}_2$	24	2.96	
15	Chloral	$\text{CCl}_3\text{CHO}$	20	2.67	
16	Thionyl chloride	$\text{SOCl}_2$	14	3.09	Slight association (sulphur hexavalent)
17	Sulfuryl chloride	$\text{SO}_2\text{Cl}_2$	14	2.97	Sulphur quadrivalent
18	Propyl chloride	$\text{C}_3\text{H}_7\text{Cl}$	21	2.93	
19	Phosphorus trichloride	$\text{PCl}_3$	16	3.03	
20	Phosphorus oxychloride	$\text{POCl}_3$	18	2.99	
21	Hydrochloric acid	$\text{HCl}$	2	3.24	Association (?)
	Mean (omitting HCl, $\text{S}_2\text{Cl}_2$ , and $\text{CCl}_3\text{CHO}$ ), 2.99				

The answer to the question whether chlorine is trivalent or monovalent is given in no indecisive manner by the method

of determining the valence from the cohesion, as is shown in columns 5 and 6 of Table I. With three possible exceptions, chlorine is seen to be everywhere trivalent. The possible exceptions are hydrochloric acid, propyl chloride and one of the chlorine atoms in germanium tetrachloride. In the first, association renders the valence of the chlorine somewhat doubtful; in other words, here also chlorine may be trivalent. In the second, propyl chloride, the critical data may be wrong. They were determined in 1886 by Vincent and Chappuis, and the other determinations by these authors give generally a value for "*a*" slightly lower than is to be expected. It is not impossible, therefore, that a redetermination of the critical data for this substance will make  $M^3K$  sufficiently high to make the chlorine trivalent. For the third substance, germanium tetrachloride, I can find but one determination of the critical data in 1887. It is not unlikely, therefore, that the data will need some revision. This method of determining the valence of chlorine confirms, therefore, the conclusions of Pascal, based on the study of the dispersion and the magnetic properties, that chlorine is polyvalent, and, further, this method shows it to be beyond doubt generally trivalent.

Moreover, since nearly all these compounds are normal and not associating, the valences of the chlorine are shown to be not resting, or in reserve, and not dissociated active valences, but actually extending between the atoms of the molecule. I have indicated in column 8 of Table I, some possible structural formulae showing how these valences may be extending in the molecule. Where there are two or more chlorine atoms in the molecule, no serious reconstruction of the graphic formulae is required, since the extra valences may be pictured as reaching between the chlorine atoms; but where there is an odd number of chlorine atoms in the molecule, or where there is but a single one, then a fundamental change must occur in the graphic formula. For example, in ethyl and methyl chlorides, the formula must be written as I have indicated, with the chlorine joining the carbon by two bonds

and with one hydrogen united to the chlorine. I do not wish to lay stress on this point until by a careful determination of the critical data the number of valences in the molecule shall have been exactly determined, but it may be pointed out that, if methyl chloride be written as:

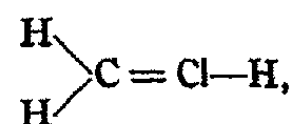

the reason why it decomposes into methylene and hydrochloric acid appears at a glance, since such a double bond is always a source of weakness; and similarly with ethyl chloride, which would be in reality ethylidene chlorhydrate, decomposing into ethylidene and hydrochloric acid. One can also more easily understand in this way the decomposition of chloroform into dichloro-methylene and hydrochloric acid, as the formula

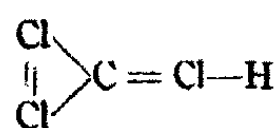

shows. Phosgen will arise from the dichloromethylene uniting with oxygen.

The evidence, then, from such various sources as the behavior toward light, the diamagnetic properties and cohesion is unanimous that chlorine is polyvalent and not monovalent; many of the chemical and physiological properties of chlorine compounds are also more easily understood on the hypothesis of its trivalency. We may, therefore, conclude that in all these compounds chlorine is trivalent.

The question which must now be settled is no longer whether chlorine is trivalent, but whether it is ever monovalent. It is certainly trivalent in most of these compounds in which it was supposed to be monovalent; it is trivalent even in its elemental state. It remains to be seen whether it is ever monovalent. In hydrochloric acid it would appear to be monovalent; but it is exactly here that association takes place. Is it without significance that exactly that compound associates which has but one of the valences of the chlorine



satisfied by another monovalent atom? Is it not rather more probable that this is the cause of its association, the other two valences being not closed, but out and active? The computation actually shows that the chlorine is here also trivalent. I know of no means of telling whether it is monovalent or trivalent in sodium chloride. But it is not impossible that sodium chloride itself is a highly associated substance. Furthermore, its power of adding iodine indicates that the chlorine may be trivalent. Friend also states that sodium chloride may be  $\text{Na} - \text{Cl} = \text{Cl} - \text{Na}$ .

Concerning the valence of the other halogens, the facts are too scanty and the data too unreliable to draw a conclusion from the cohesion, except perhaps in the case of elemental bromine, which appears to be univalent. The critical data of brombenzene and iodobenzene were not directly determined by Young, but computed from the temperature, pressure and density curves. I do not believe that they are entirely trustworthy, since the number of valences found in the molecule is too small even if these halogens are considered monovalent, unless the carbon be here trivalent, and this does not seem possible.  $T_c$  and  $V_c$  of ethyl iodide, I computed from Ramsay and Shields' surface-tension determinations, and this computation is not very accurate. Hence I do not attach much weight to the cohesive evidence of the valence of any of these compounds of bromine and iodine. There are no indications, however, that they are polyvalent. That they are polyvalent is, however, indicated from their action on light, their diamagnetic properties and many of their chemical properties. Inasmuch, however, as the refraction method is not very satisfactory for determining valence, the question of the valence of these substances must be left open, with the probability that they will be found to be polyvalent like chlorine.<sup>1</sup>

<sup>1</sup> The fact that bromine is monovalent in its elemental state may account for its relative inertness and is confirmed by its dissociation at high temperatures, when the atoms have been shown to have but one active valence. See Friend: "The Theory of Valence," 1909, p. 18.

Fluorine is apparently monovalent in fluorbenzene, since even with fluorine monovalent the number of valences computed from the cohesion is still too small. For this I can give no reason since the critical data of this substance seem to be accurately known. In methyl fluoride the total valences are computed as 9, whereas there should be 10 if fluorine is trivalent and 8 if it is monovalent. Pascal found fluorine to be monovalent by the magnetic and optical method; but Drude, from the optical behavior of calcium fluoride, believed it to be polyvalent. The critical data of more fluorine compounds must be accurately determined before the cohesion method can determine the valence of fluorine. The chemical behavior of hydrogen fluoride leaves no doubt that in it fluorine is polyvalent.

There is still another interesting conclusion from this study: it appears that all substances, and only those substances, associate, which are found by this method to contain active, free valences. I believe we may here have the explanation of the cause of association; and possibly the reason why associating substances dissolve in other associating liquids and are there normal, but as this is a separate problem in itself, I shall hope to return to it later.

#### Summary and Conclusion

1. If the valence of chlorine be determined by the cohesion method it is found to be trivalent in its elemental state and in nearly all the compounds examined. The three valences of the chlorine in these compounds are not reserve valences, but are all in action and extending between the atoms of the molecule. Graphic formulae have been suggested based on this fact.

2. This result is in harmony with the determination of the valence of chlorine by the diamagnetic and refraction method.

3. The valence of fluorine is more doubtful, but appears to be unity in fluorbenzene. Bromine has unity valence in its elemental form. The valence of iodine and bromine in

their compounds cannot be definitely determined from their cohesion on account of the inadequacy of the critical data.

4. The cohesion method detects two kinds of valences, namely, valences actually extending between the atoms and active in binding the atoms together; and valences active or open, which are in a position to unite, but to which no atoms are attached. Reserved, or resting, valences play no part as valences in molecular cohesion.

*University of Chicago*

## CONDUCTIVITY MAXIMA IN GLYCERINE

BY STEWART J. LLOYD

Absolute maxima of conductivity in aqueous solutions have long been known. Kohlrausch and Holborn<sup>1</sup> give numerous instances of such maxima with acids, bases, and salts, including lithium chloride, zinc chloride, magnesium sulphate, sodium acetate, potassium sulphide, hydrochloric, nitric, sulphuric and formic acids, potassium, sodium, and ammonium hydroxides. In fact, nearly all highly soluble salts, except those of the alkalis with strong acids, and a few like silver nitrate, appear to give maxima. The writer has not noticed, however, any record of such phenomena being observed with organic solvents. While studying at different temperatures the electrolytic deposition of zinc from concentrated solutions of its chloride in glycerine, maxima were observed and a short study of them made.

Despite the high solubility of zinc chloride in glycerine the fused anhydrous salt dissolves very slowly until the temperature is raised well above 100°. At 150° the salt appears to dissolve indefinitely, but the gradual decomposition of the glycerine in solutions held at that temperature precluded any attempt to determine the solubility more closely. Upon cooling concentrated solutions made at temperatures above 100° they solidified always to a jelly-like paste.

Measurements of the conductivity of solutions of different strengths were made at three temperatures, 50°, 100°, and 150°. An ordinary conductivity cell was used. At the temperatures in question very little trouble was experienced from air bubbles in the liquid.

The most concentrated solution used contained per cc 0.2941 gram of zinc, corresponding to 0.6131 gram zinc chloride.

The following table contains the results of the conductivity measurements:

<sup>1</sup> Leitvermögen der Electrolyte, page 145, 1898 edition.

Zinc per cc Gram	150° Resistance in ohms	100° Resistance in ohms	50° Resistance in ohms
0.2941	34.4	206	5600
0.2000	37	153	2350
0.1470	39.4	134.4	1326.1
0.1130	46.2	133	1050
0.0735	57.3	150.8	1035.2
0.0367	70	200	1301.2

From the accompanying curves the position of the maxima at the different temperatures will be fairly apparent.

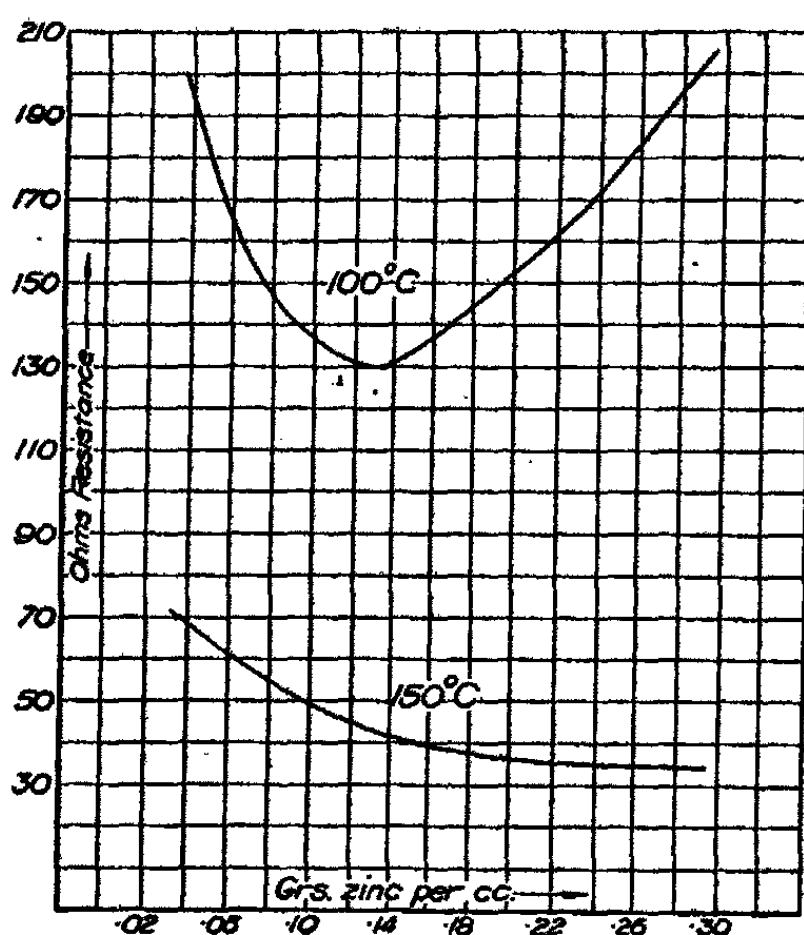

Fig. 1

Evidently the concentration giving the maximum conductivity at 150° had not been reached. At 100° the content of zinc for maximum conductivity is in the neighborhood of 0.13 gram per cc, corresponding to a zinc chloride content of 0.271 gram. At 50° the maximum corresponds to a zinc

content of about 0.09 gram, or a zinc chloride content of 0.188 gram per cc.

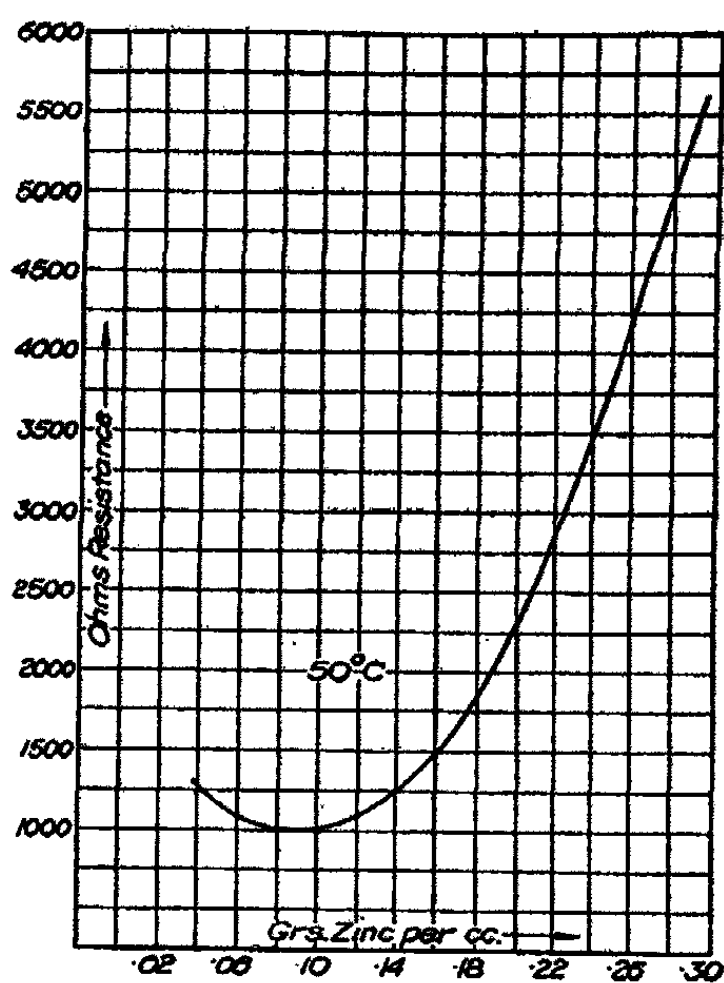

Fig. 2

Jones and Schmidt<sup>1</sup> have drawn attention to the remarkably high temperature coefficients of conductivity in fairly dilute glycerine solutions of lithium bromide, cobalt chloride, and potassium iodide, and point out the close relationship between fluidity and conductivity in such solutions. The above solutions likewise show high temperature coefficients, as may easily be seen from the data, and the parallelism between conductivity and viscosity is very apparent, especially in the case of the most concentrated solution. At 50° it was practically solid, with a correspondingly high resistance.

No attempts appear to have been made to determine

<sup>1</sup> Am. Chem. Jour., 42, 88 (1909).

just what conditions must obtain in order to bring about such maxima in aqueous solutions; whether they are due to the increasing viscosity just balancing the increase in the number of ions caused by the addition of more solute; to the addition of more solute failing to increase at all the number of ions already present; to the virtual change of solvent due to the addition of so much solute; or to a combination of these and perhaps other causes. In the present case it appears highly probable that the rapid increase in viscosity is the important factor, a view which is being subjected at present to quantitative examination in this laboratory.

*University of Alabama*  
*January, 1913*

## NEW BOOKS

*The Mechanistic Conception of Life.* By Jacques Loeb. 15 X 22 cm; 227 pp. Chicago: The University of Chicago Press, 1912.—In the preface the author says:

"The essays contained in this volume were written on different occasions, mostly in response to requests for a popular presentation of the results of the author's investigations. The title of the volume characterizes their general tendency as an attempt to analyze life from a purely physico-chemical viewpoint."

The essays are entitled: *The Mechanistic Conception of Life; The Significance of Tropisms for Psychology; Some Fundamental Facts and Conceptions concerning the Comparative Physiology of the Central Nervous System; Pattern Adaptation of Fishes and the Mechanism of Vision; on Some Facts and Principles of Physiological Morphology; On the Nature of the Process of Fertilization; On the Nature of Formative Stimulation (Artificial Parthenogenesis); The Prevention of the Death of the Egg through the Act of Fertilization; The Role of Salts in the Preservation of Life; Experimental Study of the Influence of Environment on Animals.*

The author's point of view will be seen from the following quotations, pp. 26, 30, 42, 48, 71, 73, 80, 100, 158, 169, 204:

"If the structure and the mechanism of the atoms were known to us we should probably also get an insight into a world of wonderful harmonies and apparent adaptations of the parts to the whole. But in this case we should quickly understand that the chemical elements are only the few durable systems among a large number of possible but not durable combinations. Nobody doubts that the durable chemical elements are only the product of blind forces. There is no reason for conceiving otherwise the durable systems in living nature.

"The contents of life from the cradle to the bier are wishes and hopes, efforts and struggles, and unfortunately also disappointments and suffering. And this inner life should be amenable to a physico-chemical analysis? In spite of the gulf which separates us to-day from such an aim I believe that it is attainable. As long as a life phenomenon has not yet found a physico-chemical explanation, it usually appears inexplicable. If the veil is once lifted we are always surprised that we did not guess from the first what was behind it.

"That in the case of our inner life a physico-chemical explanation is not beyond the realm of possibility is proved by the fact that it is already possible for us to explain cases of simple manifestations of animal instinct and will on a physico-chemical basis; namely, the phenomena which I have discussed in former papers under the name of animal tropisms. As the most simple example we may mention the tendency of certain animals to fly or creep to the light. We are dealing in this case with the manifestation of an instinct or impulse which the animals cannot resist. It appears as if this blind instinct which these animals must follow, although it may cost them their life, might be explained by the same law of Bunsen and Roscoe, which explains the photochemical effects in inanimate nature.



"Our wishes and hopes, disappointments and sufferings, have their source in instincts which are comparable to the light instinct of the heliotropic animals. The need of and the struggle for food, the sexual instinct with its poetry and its chain of consequences, the maternal instincts with the felicity and the suffering caused by them, the instinct of workmanship, and some other instincts are the roots from which our inner life develops. For some of these instincts the chemical basis is at least sufficiently indicated to arouse the hope that their analysis, from the mechanistic point of view, is only a question of time.

"If our existence is based on the play of blind forces and only a matter of chance, if we ourselves are only chemical mechanisms—how can there be any ethics for us? The answer is, that our instincts are the root of our ethics and that the instincts are just as hereditary as is the form of our body. We eat, drink, and reproduce, not because mankind has reached an agreement that this is desirable, but because, machine-like, we are compelled to do so. We are active, because we are compelled to be so by processes in our central nervous system; and as long as human beings are not economic slaves the instinct of successful work or of workmanship determines the direction of their action. The mother loves and cares for her children, not because metaphysicians had the idea that this was desirable, but because the instinct of taking care of the young is inherited just as distinctly as the morphological characters of the female body. We seek and enjoy the fellowship of human beings because hereditary conditions compel us to do so. We struggle for justice and truth since we are instinctively compelled to see our fellow beings happy. Economic, social, and political conditions or ignorance and superstition may warp and inhibit the inherited instincts and thus create a civilization with a faulty or low development of ethics. Individual mutants may arise in which one or the other desirable instinct is lost, just as individual mutants without pigment may arise in animals; and the offspring of such mutants may, if numerous enough, lower the ethical status of a community. Not only is the mechanistic conception of life compatible with ethics: it seems the only conception of life which can lead to an understanding of the source of ethics.

"Many animals show no heliotropism at all; many show only a slight reaction, while others show it in a degree as pronounced as do the winged aphids. The problem therefore presented itself of producing heliotropism artificially in animals; which, under natural conditions, show no positive heliotropism. If small crustaceans of a fresh-water pond or lake are taken with a plankton net at noontime or in the afternoon and placed in an aquarium which is illuminated from one side only, it is often found that these animals move about in the vessel pretty much at random and distribute themselves irregularly. Some seem to go more toward the source of light, others in the opposite direction, and the majority perhaps pay no attention to the light.

"This condition changes instantly if we add to the water some acid, preferably carbonic acid, which easily penetrates the cells of the animals. To every 50 cc of the fresh water a few cc of water charged with carbon dioxide are slowly added. If the correct amount is added all the individuals become actively heliotropic and move in as straight a line as the imperfection of their swimming movements permits toward the source of light, and remain there closely crowded together on the illuminated side of the vessel. If the vessel is turned 180°,

they go directly back again to the lighted side of the vessel. Every other acid acts like carbonic acid and alcohol acts in the same manner, only more weakly and much more slowly. Animals which were previously indifferent to light become under carbonic acid treatment complete slaves of the light.

"How does the acid produce this result? We will assume that it acts as a sensitizer. The light produces chemical changes, for instance, oxidation, on the surface of the animal, especially in the eye, as was suggested in the case of the aphids. The mass of photochemical substance which is acted upon by the light is often relatively small, so that even when the light strikes the crustacean (copepod) on one side only, the difference in the chemical changes on the two sides of the body remains still too small to call forth a difference in tension or action in the muscles of the two sides of the body, sufficient to turn the animal toward the source of light. But if we add an acid this could act as a catalyzer, as, for instance, in the *catalysis of esters*. In the *catalysis of esters*, the acid acts, according to Stieglitz, only to the extent of increasing the active mass of the substance which undergoes a chemical change. In order to fix our ideas provisionally we will assume that the acid makes the animal more strongly positively heliotropic by increasing the active mass of the photosensitive substance. In this way the same intensity of light which before produced no heliotropic reaction now may cause a very pronounced positively heliotropic reaction; because if now the animal is struck on one side only by the light, the difference in the reaction products in both retinae becomes rapidly large enough to cause automatically a difference in the action of the muscles of both sides of the body and a turning of the head toward the source of light.

"It is a common phenomenon that animals in certain larval stages are positively heliotropic, while in others they are not sensitive to light or are even negatively heliotropic. I will not discuss these facts further in this place, but refer my readers to my earlier papers.

"This change in the heliotropic sensitiveness, produced by certain metabolic products in the animal body, is of great biological significance. I pointed out in former papers that it serves to save the lives of the above-mentioned young larvae of *Chrysorrhoea*. When the young larvae are awakened from their winter sleep by the sunshine of the spring they are positively heliotropic. Their positive heliotropism leaves them no freedom of movement, but forces them to creep straight upward to the top of a tree or branch. Here they find the first buds. In this way their heliotropism guides them to their food. Should they now remain positively heliotropic they would be held fast on the ends of the twigs and would starve to death. But we have already mentioned that after having eaten they once more lose their positive heliotropism. They can now creep downward, and the restlessness which is characteristic of so many animals forces them to creep downward until they reach a new leaf, the odor of tactile stimulus of which stops the progressive movement of the machine and sets their eating activity again in motion.

"The fact that ants and bees become positively heliotropic at the time of sexual maturity plays an important rôle in the vital economy of these creatures. As is well-known, the mating of these insects takes place during the so-called nuptial flight. I found that among the male and female ants of a nest the heliotropic sensitiveness increases steadily up to the time of the nuptial flight and

that the direction of their flight follows the direction of the rays of the sun. I gained the impression that this nuptial flight is merely the consequence of a very highly developed heliotropic sensitiveness. The case seems to be similar among the bees according to the following experiment described by Kellogg. The bees were ready to swarm out of the opening of the box used for the experiment when he suddenly removed the dark covering of the box so that the light now entered it from above. The heliotropic sensitiveness of the animals was so great that they crept upward within the box, following the direction of the light rays, and were not able to make the nuptial flight. Thus according to these observations the bees at the time of the nuptial flight are positively heliotropic machines.

"We must discriminate between simple and conscious spontaneity. In simple spontaneity we must consider two kinds of processes, namely, aperiodic spontaneous processes and rhythmically spontaneous or automatic processes. The rhythmical processes are of importance for our consideration. Respiration and the heartbeat belong in this category. The respiratory movements seem to indicate that automatic activity *can* arise in the ganglion-cells, and from this the conclusion has been drawn that all automatic movements are due to specific structures of the ganglion-cells. Recent investigations, however, have transferred the problem of rhythmical spontaneous contractions from the field of morphology into that of physical chemistry. The peculiar qualities of each tissue are partly due to the fact that it contains certain ions (Na, K, Ca and others) in definite proportions. By changing these proportions, we can impart to a tissue properties which it does not ordinarily possess. If in the muscles of the skeleton the Na ions be increased and the Ca ions be reduced, the muscles are able to contract rhythmically like the heart. It is only the presence of Ca ions in the blood which prevents the muscles of our skeleton from beating rhythmically in our body. As the muscles contain no ganglion-cells, it is certain that the power of rhythmical spontaneous contractions is not due to the specific morphological character of the ganglion-cells, but to definite chemical conditions which are not necessarily confined to ganglion-cells.

"Consciousness is only a metaphysical term for phenomena which are determined by associative memory. By associative memory I mean that mechanism by which a stimulus brings about not only the effects which its nature and the specific structure of the irritable organ call for, but by which it brings about also the effects of other stimuli which formerly acted upon the organism almost or quite simultaneously with the stimulus in question. If an animal can be trained, if it can learn, it possesses associative memory. By means of this criterion it can be shown that Infusoria, Coelenterates, and worms do not possess a trace of associative memory. Among certain classes of insects (for instance, ants, bees, and wasps), the existence of associative memory can be proved. It is a comparatively easy task to find out which representatives of the various classes of animals possess, and which do not possess, associative memory. Our criterion, therefore, might be of great assistance in the development of comparative psychology.

"Our criterion puts an end to the metaphysical idea that all matter, and hence the whole world, possesses consciousness. We are brought to the theory that only certain species of animals possess associative memory and have con-

sciousness, and that it appears in them only after they have reached a certain stage in their ontogenetic development. This is apparent from the fact that associative memory depends upon mechanical arrangements which are present only in certain animals, and present in these only after a certain development has been reached. The fact that certain vertebrates lose all power of associative memory after the destruction of the cerebral hemispheres, and the fact that vertebrates in which the associative memory either is not developed at all or only slightly developed (*e. g.*, the shark or frog) do not differ, or differ but slightly in their reactions after losing the cerebral hemispheres, support this view. The fact that only certain animals possess the necessary mechanical arrangements for associative memory, and, therefore, for consciousness, is not stranger than the fact that only certain animals possess the mechanical arrangements for uniting the rays from a luminous point on the retina. The liquefaction of gases is an example of a sudden change of condition which may be produced when one variable is changed; it is not surprising that there should be sudden changes in the ontogenetic and phylogenetic development of organisms when there are so many variables subject to change, and when we consider that colloids easily change their state of matter.

"It becomes evident that the unraveling of the mechanism of associative memory is the great discovery to be made in the field of brain physiology and psychology. But at the same time it is evident that this mechanism cannot be unraveled by histological methods, or by operations on the brain, or by measuring reaction times. We have to remember that all life phenomena are ultimately due to motions or changes occurring in colloidal substances. The question is, Which peculiarities of the colloidal substances can make the phenomenon of associative memory possible? For the solution of this problem the experience of physical chemistry and of the physiology of the protoplasm must be combined. From the same sources we must expect the solution of the other fundamental problems of brain physiology, namely, the process of conduction of stimuli.

"The idea that the formation of the vertebrate embryo is a function of growth has been made the basis of the embryological investigations of His. In a masterly way, His has shown how inequality of growth determines the differentiation of organs. In the blastoderm of a chick, for example, the first step in the formation of the embryo is a process of folding. There originates a head fold, a tail fold, a medullary groove, and the system of amniotic folds. According to His, all these processes of folding are due simply to inequalities of growth, the center of the blastoderm growing more rapidly than the periphery. It can be shown, very simply, that such a process of unequal growth must, indeed, lead to the formation of exactly such a system of folds as we find in the blastoderm of a chick. If we take a thin, flat plate of elastic rubber, and lay it on a drawing-board, we can imitate the stronger growth in the center by sticking two tacks in the middle of the rubber, a short distance apart, and then pulling them in opposite directions. In this way we may imitate unequal growth, the center growing faster than the periphery. If we then fix the tacks in the drawing-board, so that the rubber in the middle remains stretched, we get the same system of folds as that shown by the embryo of a chick. I mention this

way of demonstrating the effects of unequal growth as the ideas of His are still doubted by some morphologists.

"His raised the question, Why is growth different in different parts of the blastoderm? But instead of trying to answer it from the physiological standpoint he answered it from the anatomical standpoint. According to him, the different regions of the unsegmented egg correspond already to the different regions of the differentiated embryo. But this so-called theory of preformed germ-regions gives no answer to the question, why some parts of the embryo grow faster than others. Nevertheless, it is not necessarily in opposition to the theory of growth offered in the preceding chapter. Starting with the idea of His, we may well imagine that the different regions of the ovum are somewhat different chemically, and that these chemical differences of the different germ-regions determine the differences of growth in the blastoderm. Thus the phenomena of heteromorphosis would show that, in some animals at least, the arrangement of preformed germ-regions may be changed by gravitation, light, adhesion, etc.

"How can we explain the fact that fertilization saves the life of an egg? Let us make the following preliminary assumption: The unfertilized egg contains a poison, or some faulty combination of conditions which, if oxidations take place, causes the death of the egg. In the unfertilized but mature egg oxidations take place. The spermatozoon carries into the egg among other substances something which protects the egg against the fatal effects of the oxidations, and allows them even to carry on oxidations at an increased rate without suffering. We might say that the mature but unfertilized egg is comparable to an anaerobic being for which oxidations are fatal, and that the spermatozoon transforms the egg into an aerobic organism.

"If we compare the eggs of different animals, we find great differences in regard to the above-mentioned conditions. The eggs of certain annelids (*Polynoe*) also perish rapidly if they become mature without being caused to develop, while the eggs of the sea-urchin remain alive for a longer period of time after they have become mature. The problem as to what determines this difference has not yet been investigated.

"Less is known of the rôle of the salts in the animal body than of the rôle of the three other main food-stuffs, namely, carbohydrates, fats, and proteins. As far as the latter are concerned we know at least that through oxidation they are capable of furnishing heat and other forms of energy. The neutral salts, however, are not oxidizable. Yet it seems to be a fact that no animal can live on an ash-free diet indefinitely, although no one can say why this should be so. We have a point of attack for the investigation of the rôle of the salts in the fact that the cells of our body live longest in a liquid which contains the three salts, NaCl, KCl and CaCl<sub>2</sub> in a definite proportion, namely, 100 molecules NaCl, 2.2 molecules KCl and 1.5 molecules of CaCl<sub>2</sub>. This proportion is identical with the proportion in which these salts are contained in sea-water; but the concentration of the three salts is not the same in both cases. It is about three times as high in the sea-water as in our blood serum.

"Biologists have long been aware of the fact that the ocean has an incomparably richer fauna than fresh-water lakes or streams and it is often assumed that life on our planet originated in the ocean. The fact that the salts of Na, Ca

and K exist in about the same proportion in our blood serum as in the ocean has led some authors to the conclusion that our ancestors were marine animals, and that, as a kind of inheritance, we still carry diluted sea-water in our blood. Statements of this kind have mainly a metaphorical value, but they serve to emphasize the facts that the three salts, NaCl, KCl and CaCl<sub>2</sub>, exist in our blood in the same relative proportion as in the ocean and that they seem to play an important rôle in the maintenance of life.

"The reader is probably familiar with the fact that there exist two different types of human twins. In the one type the twins differ as much as two children of the same parents born at different periods; they may or may not have the same sex. In the second type the twins have invariably the same sex and resemble each other most closely. Twins of the latter type are produced from the same egg, while twins of the former type are produced from two different eggs.

"The experiments of Driesch and others have taught us that twins originate from one egg in this manner, namely, that the first two cells into which the egg divides after fertilization become separated from each other. This separation can be brought about by a change in the chemical constitution of the sea-water. Herbst observed that if the fertilized eggs of the sea-urchin are put into sea-water which is freed from calcium, the cells into which the egg divides have a tendency to fall apart. Driesch afterward noticed that eggs of the sea-urchin treated with sea-water which is free from lime have a tendency to give rise to twins. The writer has recently found that twins can be produced not only by the absence of lime, but also through the absence of sodium or potassium; in other words, through the absence of one or two of the three important metals in the sea-water. There is however a second condition, namely, that the solution used for the production of twins must have a neutral or at least not an alkaline reaction.

"The procedure for the production of twins in the sea-urchin egg consists simply in this: the eggs are fertilized as usual in normal sea-water and then, after repeated washing in a neutral solution of sodium chloride (of the concentration of the sea-water), are placed in a neutral mixture of potassium chloride and calcium chloride, or of sodium chloride and potassium chloride, or of sodium chloride and calcium chloride, or of sodium chloride and magnesium chloride. The eggs must remain in this solution until half an hour or an hour after they have reached the two-cell stage. They are then transferred into normal sea-water and allowed to develop. From 50 to 90 percent of the eggs of *Strongylocentrotus purpuratus* treated in this manner may develop into twins. These twins may remain separate or grow partially together and form double monsters, or heal together so completely that only slight or even no imperfections indicate that the individual started its career as a pair of twins. It is also possible to control the tendency of such twins to grow together by a change in the constitution of the sea-water. If we use a twin-producing solution, a mixture of sodium, magnesium, and potassium chlorides (in the proportion in which these salts exist in the sea-water), the tendency of the twins to grow together is much more pronounced than if we use simply a mixture of sodium chloride and magnesium chloride."

*Wilder D. Bancroft*

**The Metallography of Iron and Steel.** By Albert Sauveur. 18 × 26 cm; pp. xvi + 413. Cambridge: Sauveur and Boylston, 1912. Price: \$6.00.—In the preface the author says:

"While several excellent books on metallography have been published and while numerous papers on the metallography of iron and steel have appeared in the scientific and technical press, a well-balanced, specific, and comprehensive treatise on the subject has not heretofore been written. In the belief that there is a real and urgent need of such a treatise, the author has endeavored to supply it, craving for his effort the indulgent criticism of his readers. He offers his book to those seeking self-instruction in the metallography of iron and steel, their special needs having been carefully considered in the arrangement of the lessons; he offers it to teachers and students trusting that they will find it valuable and suggestive as a text book; he offers it to manufacturers and users of iron and steel in the belief that he has given due weight to the practical side of the subject and has avoided discussions of ill-founded or purely speculative theories; he offers it to the general reader interested in the scientific or practical features of the metallography of iron and steel, as the language used should be readily understood by those lacking specialized knowledge of the subject; he offers it to experts in the hope that they will find it not entirely devoid of original thought, original treatment, and suggestiveness."

The subject is presented under the following headings: apparatus for the metallographic laboratory; pure metals; pure iron; wrought iron; low carbon steel, medium high and high carbon steel; impurities in steel; the thermal critical points of iron and steel; cast steel; the mechanical treatment of steel; the annealing of steel; the hardening of steel; the tempering of hardened steel; theories of the hardening of steel; the cementation and case-hardening of steel; special steels; cast iron; impurities in cast iron; malleable cast iron; constitution of metallic alloys; equilibrium diagram of iron-carbon alloys; the phase rule; manipulations and apparatus; nomenclature of the microscopic constituents.

The author has had much experience in correspondence work and it shows. He has written a very readable book. It is rather to be regretted that he looks upon ferrite and graphite as the only two stable phases and it is quite unpardonable that the book should not be paged continuously. If the chapter on the phase rule is to come after the iron-carbon diagram, why not omit it altogether?

What the author has to say on mechanical refining is interesting (Lesson XI, p. 9): "It would seem as if, with the use of pyrometers at least, it should be a relatively simple matter to finish steel objects very near the desirable temperature and thus secure for them the best structure that can be imparted by work alone. Upon reflection, however, it will be manifest that the problem is on the contrary an insoluble one, for the reason that unless the objects are of very small cross-sections, it is quite impossible to finish them so that their temperature will be uniform throughout, the central portions being necessarily hotter than the outside. Should the forging be so conducted that the temperature of the outside be very near the critical range, the center, being materially hotter, will coarsen on cooling, while if the implements, on the contrary, are finished so that their center may have the fine structure produced by ceasing the work at the proper temperature, their outside must necessarily suffer from cold working.



The limitations of work alone as a means of imparting the best possible structure to steel are, therefore, quite evident.

"While a uniformly fine grain cannot be imparted to steel objects of considerable size through hot working alone, the value of hot work as a means of refining the structure of steel remains very great as exemplified by the structure of properly hot forged steel when compared with the structure of steel castings of similar composition. The finer grain imparted to steel by working it has been called by some writers 'mechanical' refining to distinguish it from the refining produced by heat, *i. e.*, from 'thermal' refining. In practice hot work should be so conducted, that is, the finishing temperatures so regulated, that the central portions of the finished implements will not suffer unduly from the coarsening influence of too high a finishing temperature, while at the same time the outside will not suffer unduly from the effect of cold working. The natural tendency of rolling and other forging mills is to finish work at too high temperatures for the simple reason that the metal is then more plastic and consequently requires less power for its working. In some manufactures, however, and especially in the rolling of rails, the importance of proper finishing temperatures has been given careful attention and the rolling operation so modified as to deliver rails of much finer grain, and, therefore, better physical quality than formerly.

"Besides its important grain refining influences hot work further improves the quality of steel by closing and, if the carbon be low enough, welding the blow-holes and otherwise increasing its soundness and by removing cooling strains."

In Lesson XII, p. 2, we read that "having imparted a fine structure to the steel the next step must be to retain it. The most effective way of accomplishing this consists in cooling the steel very quickly, by quenching it in water, for instance, as time is then denied for the structure to coarsen at all while the metal cools to atmospheric temperature. Such rapid cooling, however, as is well known, hardens the metal and deprives it of ductility (unless indeed it contains very little carbon), and this would defeat the purpose of annealing which always demands the retention of considerable ductility. It follows from these considerations that, in annealing, cooling from the annealing temperature cannot be so rapid as to very materially harden the steel. Its rate should, moreover, be regulated in accordance with the kind of properties we most desire the steel object to possess. For instance, (1) if softness and ductility are wanted (for ease of machining), necessarily at a certain sacrifice of strength and elasticity, the cooling should be very slow, to wit, with the furnace in which the object was heated, (2) if greater hardness (for wearing power), strength and elasticity are desired, at the necessary sacrifice of some ductility, the cooling should be more rapid, as, for example, in air or, in the case of low carbon steel, in oil or, with very low carbon steel, even in water."

After giving an account of the different theories of the hardening of steel the author sums up as follows (Lesson XV, p. 6):

"From the above short description of the various theories advanced to explain the hardening of steel the reader will probably gather the impression that the retention theories, especially the beta iron theory, are the most acceptable ones. It seems quite possible, however, even probable, that the various theories while apparently antagonistic, bring each their contribution to the elucidation of the problem. Should we not believe with the allotropists that the hardness



of steel is due chiefly to the retention of a large quantity of a hard allotropic variety of iron, probably beta iron, and that this iron contains in solution the hardening carbon of the carbonists, the presence of which is absolutely essential to the existence of beta iron in the cold? Should we not with the advocates of the stress theories believe in the hardening influence of the strains created on quick cooling (a) because of the shrinkage of the outer layers of the metal and (b) because of the expansion accompanying the transformation of gamma into beta iron? None of these theories alone gives a fully satisfactory explanation: beta iron cannot be retained in the absence of carbon and if it could be it is not certain that it would be intensely hard; the presence of intensely hard carbon or iron carbide as the chief cause of hardening is contrary to evidences; the strained condition of hardened steel does not account satisfactorily for its hardness; Le Chatelier's contention that quickly cooled steel is hard although its iron is in the soft alpha condition because of its being in a state of solution is opposed by the evidences at hand (a) of the existence of beta iron and (b) of the hardness of beta iron: Arnold's theory that hardened steel owes its hardness to the retention of a hard subcarbide of iron lacks experimental support and is scientifically untenable."

Wilder D. Bancroft

**Explosives.** By H. Brunswig. Translated by Charles E. Munroe and Allon L. Kibler. 14 X 20 cm; pp. xv + 350. New York: John Wiley and Sons, 1912.—In the preface the author says that "the application of physical chemistry to the problems of explosives is to be desired for several reasons. . . . The days of purely empirical progress in the technique of explosives are numbered. The development of our knowledge of explosive processes forces us more and more into the narrow field of an exact chemistry of explosives, or, in other words, a physical chemical science dealing with the velocities of chemical reactions and chemical equilibria at very high temperatures and pressures."

The headings of the chapters are: general behavior of explosive systems; velocity of explosive reactions; explosion pressure; temperature of explosion; gases from explosive reactions; explosions by influence; flame of an explosion; characteristics of particular explosions; propellants; blasting explosives.

As illustrating the difference between exothermal and endothermal reactions, the author points out, p. 4, that "a mixture of porous carbon with liquid oxygen is explosive, while liquid carbon dioxide is not, although both systems, in going over to gaseous carbon dioxide, reach the same final condition with a nearly equal increase of volume." On p. 13 we read that "a surprising result is obtained by a comparison of the energy content, expressed in calories, of the explosion of powerful explosive substances with that of the burning of ordinary fuels. Thus one kilogram of petroleum in burning to carbon dioxide and water furnishes about 12,000 calories; coal about 8000 calories; and dry wood, 3500-4000 calories; while dynamite (with 25 percent kieselguhr) in exploding furnishes only 1300 calories. The energy content of explosives is usually thought to be very great, while really they are technically valuable only because they liberate all their energy in a very short space of time. As a fact, explosives are unproductive and costly sources of energy."

The following paragraphs on sensitiveness, p. 19, and on detonators, pp. 35 and 47, are interesting:

"From the foregoing, sensitiveness and heat of formation appear to be related, yet the laws of this relationship have not been completely explained. This is probably due to the influence which the physical condition of the explosive substance exercises on its sensitiveness, and this is a factor which is very difficult to bring under a common law. Among them might be mentioned physical state, viscosity, structure, density, hardness and perhaps also conductivity for heat, sound and the like. In the test for sensitiveness such considerations are often much more important than differences in the atomic structure of the molecule. By successive compressions of an explosive mixture its sensitiveness can be brought to the vanishing point, a fact which has often been noticed in the case of compressed detonators as well as cartridges and explosives; it has been observed by Berthelot and others even in the case of highly sensitive chlorate mixtures.

"The sensitiveness of an explosive apparently bears no relationship to that of its component parts. This applies also to added substances which in themselves are not explosive. It is a well-known fact that hard, sharp-edged admixtures, such as sand, powdered glass and even metallic particles, increase considerably the sensitiveness of an explosive towards shock, blow and friction, and the explosives industry makes frequent use of this principle. It has not yet been indisputably demonstrated that the influence of such hard admixtures upon the sensitiveness under a blow is due to the concentration of the pressure on the sand or glass points. The sensitiveness is often greater on softer metals than on harder ones. Yet admixtures lessen the sensitiveness when they have a tendency to soften the explosives, or, when they inclose its smallest particles like an elastic envelope. For this reason, substances such as water, methyl alcohol, acetone, also glycerin, paraffin, vaselin, and even camphor, caoutchouc, and fatty oils have found applications as admixtures in the manufacture of explosives. It is found, for example, that if cottonseed oil be mixed in varying proportions with finely crystallized picric acid, the addition of more than 3.2 percent of oil to the picric acid entirely destroys its ability to be detonated by blows or friction, and even by the influence of 2-gram detonators. Other fatty oils, especially castor oil, have a similar effect and each of such admixtures seems to have its own specific influence. If the protecting envelope, which weakens the effect of the initial impulse upon the explosive, is broken, even partly, the sensitiveness again increases. If, for instance, a mixture of 9 parts picric acid with 1 part nitronaphthalene be warmed until the latter melts, and then the mixture is allowed to cool and solidify, the mass cannot be caused to explode by the detonation of a 2-gram detonator. If the same mass be now finely powdered, and then compressed to the same density as the previous solid mass, it can be detonated without fail with a 1-gram detonator.

"M. Berthelot has sought to prove that mechanical shock does not, as a rule, cause the explosion directly but indirectly through the heat produced. Previous to this, chemists were inclined to the opinion, on the strength of experiments with very sensitive explosives such as silver fulminate, nitrogen iodide, nitrogen chloride and the like, that violent agitations of the particles of the substance could directly bring about chemical reaction. M. Berthelot's experiments, however, prove that a reaction, even one that is already begun, is not accelerated when the substance in reaction is placed on a tuning fork or in a

glass tube vibrating over 7000 times per second. As a fact, nitrogen iodide did explode at from 100 to 200 vibrations, but only because the vibrations produced a rise of temperature sufficient for more rapid decomposition.

"The phenomena of the transmission of an explosion from one explosive cartridge to another separated from it (section 28) proves, however, that very violent vibrations, as such, can bring about an explosive reaction.

"The explosive reaction brought about by a detonator owes its peculiar character to the circumstance that it proceeds nearly adiabatically; that is, the amount of heat carried off in unit of time by radiation or conduction is vanishingly small compared to that developed in the same time by chemical reaction."

Under the velocity of explosive reactions, p. 85, we learn that "investigators have accepted the assumption that the grains of black powder burn in concentric layers and that, therefore, during the process of combustion a proportion exists between the time consumed in burning and the thickness of the layer burned. Vieille proved, in a suggestive work, that this hypothesis is not true in general for black powder; but is true for explosives, such as gelatinized nitrocellulose, which possess a nearly homogeneous character. . . . By the establishment of these facts Vieille laid the foundation for the modern gelatinized smokeless gunpowder, which, on account of its regular velocity of combustion within wide limits, allows a much higher utilization of its energy than was possible in the case of black powder without injuring the weapon to any material extent."

One unexpected source of danger is mentioned on p. 222:

"The power of nitrocellulose to collect static electricity is not only troublesome but has frequently been the cause of accidents due to a discharge of electricity in the form of sparks. An unusual occurrence which took place in the powder factory of the Nobel's Explosive Company in Ardeer, on Dec. 14, 1901, was due to the electrification of gelatinized powder when rubbed. A workman engaged in winding up strings of cordite allowed the strands to run through his hand. The floor of the room was covered with lead, and the workman wore shoes with rubber soles. As he started to dip his fingers in a dish of acetone to free them of the fragments of cordite a spark sprang from his fingers to the acetone and ignited it. The workman was apparently charged with static electricity from rubbing the cordite. In fact, the experience was afterwards repeated as an experiment and was always successful so long as the workman was insulated. It could not be accomplished, however, after a copper nail had been driven in the rubber sole of his shoe. The nail acted as a conductor and carried off the electricity through the lead floor."

The only error which comes within the reviewer's knowledge is on p. 53 where the author cites the work of Falk to the effect that the mixture,  $H_2 + O_2$ , is most easily detonated without referring to the subsequent work of Dixon which showed the error in the experimental work. *Wilder D. Bancroft*

*Untersuchungen über die Bildungsverhältnisse der ozeanischen Salzablagerungen.* By J. H. van't Hoff. 18 × 26 cm; pp. xx + 374. Leipzig: Akademische Verlagsgesellschaft, 1912.—The monumental work of van't Hoff on the Stassfurt salt deposits was published in the Transactions of the Prussian Academy of Sciences in fifty-two papers extending over eleven years. Under the circumstances the papers were not readily accessible as a whole. Messrs.

Cohen and Precht have done the chemical world a favor by republishing these papers in a single volume. Since the papers really are the first stages of a revolution in geology, it is difficult to overestimate their importance. In fact, most chemists have not waked up as yet to their real significance. In the memorial address on van't Hoff, Emil Fischer says quite frankly that many of van't Hoff's friends considered the Berlin days as a period of rest or even of exhaustion. Such a belief is due to a lack of perspective. To revolutionize geology is no small matter. The Geophysical Laboratory at Washington is carrying on in splendid style the work which van't Hoff began. It is very doubtful whether the Geophysical Laboratory could have been founded when it was, had it not been for the pioneer work of van't Hoff, which rests in its turn on the work of Roozeboom, which was a continuation of the work of Gibbs.

*Wilder D. Bancroft*

**The Principles of Organic Chemistry.** By James F. Norris. 15 X 21 cm.; pp. v + 565. New York: McGraw-Hill Book Co., 1912.—This book is one of the first of the International Chemical Series to appear; while intended for beginners, it is a little more advanced than Remsen's, and a little more elementary than Bernthsen's book. The order followed is practically the same as that of the latter book. The emphasis laid on the foundation for this treatment, however, is of interest. Radicals are treated on the basis of hydrogen as standard. Those more basic than hydrogen are called positive, and those more acid in nature, negative. According to this, the classification of organic chemistry partakes somewhat of that of inorganic. First, the organic unit, or radical, corresponding to the element in inorganic chemistry, is treated. Then in order a positive group connected with a hydroxyl group; alcohols; a negative group with hydroxyl acids; two positives with oxygen, ethers; two negatives with oxygen, anhydrides; and etc., emphasizing the similarity with inorganic bases, acids, oxides, acid anhydrides, and etc.

The chapters on carbohydrates, proteins, and dyes are especially worthy of comment. More attention is given these subjects than in the ordinary elementary text book. The growing interest in dyeing, the importance of proteins in all life processes, and the commercial importance of the carbohydrates, require that the ordinary student should have a more intimate acquaintance with these everyday substances. The chapter on identification of organic compounds may be of some value in giving the student an idea of the nature of organic analysis. On the other hand, the attempt to treat analysis in a chapter of fifteen pages might mislead some students.

The book is practical, and should be used by those desiring a less advanced work than the Bernthsen, but similar in make-up. It is printed on thin, but good paper, so that although consisting of about 600 pages, it is small and attractive.

*C. W. Bennett*

# THE ELECTROCHEMICAL PRODUCTION OF COLLOIDAL COPPER

BY T. ROLAND BRIGGS

## PART I—SCHÜTZENBERGER'S ALLOTROPIC COPPER

In the year 1878, Schützenberger<sup>1</sup> announced to the French Academy a new and allotropic modification of copper which he had prepared by the electrolysis of a neutral aqueous solution of cupric acetate. He was greatly impressed with the peculiar properties of the new form of copper and proceeded at once to its further investigation. I quote from his first paper:

"The following facts establish the existence of an allotropic modification of copper, distinct in its physical and chemical properties. The electrolyte employed is a ten percent, aqueous solution of copper acetate, which has been boiled for several minutes. . . . There are employed two Bunsen or three Daniell cells of moderate size and all rise in temperature during the electrolysis is to be avoided. The negative platinum plate is placed [opposite and] parallel to the sheet of copper serving as the soluble positive electrode, at a distance of three or four centimeters. Its size should be a little less than that of the positive electrode. Under these conditions the face of the negative platinum electrode becomes covered with a deposit of allotropic copper.

"*Physical Properties.*—The allotropic copper occurs in layers having a metallic lustre. . . . and is less red than ordinary copper, resembling certain bronzes. It is brittle, absolutely lacks malleability and can be reduced to an impalpable powder. . . ."

Schützenberger continues by pointing out that the density of the new form of copper varies between 8.0 and 8.2, which is decidedly less than that of ordinary sheet copper. He continues:

<sup>1</sup> Comptes rendus, 86, 1265 (1878).

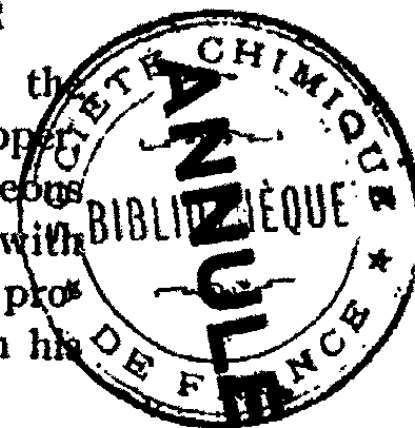

*Chemical Properties.*—The layers, washed with previously boiled water and exposed while moist to the air, are superficially oxidized with great rapidity; they become beautifully iridescent and in a few moments take on a deep indigo-blue color. In warm water, from 50 to 60 degrees in temperature, and in slightly basic copper acetate solution, the oxidation is instantaneous. In the beginning, the electrolysis of a bath of basic acetate gives only deposits rich in copper acetate and it is only after a certain time, when the bath has become more nearly neutral, that the operation goes properly.

“The allotropic copper, exposed to the air as a dry powder and at the ordinary temperature, blackens after a short time and changes to copper oxide.

“The way in which it acts with pure nitric acid, cold and diluted with ten times its weight of water, is characteristic; its surface is quickly cleaned [of oxide] and the metal is attacked with the immediate evolution of nearly pure nitrous oxide, at the same time becoming covered with an olive-black layer of unknown nature. Ordinary copper is with difficulty attacked by acid of this strength, while with more concentrated acid it gives off mainly nitric oxide, and this without any blackening. Sometimes samples [of allotropic copper] are obtained which evolve mixtures of nitrous and nitric oxides when dissolved in nitric acid but it is easy to show that this [mixture] is formed from the presence of both forms of copper. This effect often occurs when the bath becomes warm during the electrolysis or if it contains acid.

“The allotropic copper is converted into ordinary copper by the action of heat or by prolonged contact with a dilute solution of sulphuric acid.

“Heated to 100° Centigrade in a vacuum or in carbon dioxide the modified copper does not disengage hydrogen. The peculiarities of its physical and chemical properties should not be attributed to the presence of a hydride of copper nor to occluded hydrogen, and can be explained only by the existence of a special form of copper, susceptible to oxidation and dissolving in nitric acid with an evolution of nitrous oxide

even in the cold. It is quite probable that this modification corresponds to the copper of the cupric salts. In changing to ordinary copper it polymerizes, evolves heat and gives by oxidation cuprous oxide before passing to the final state of cupric oxide."

In a second paper<sup>1</sup> Schützenberger described further experiments upon allotropic copper and also mentioned the preparation of an allotropic form of lead. From lead acetate solutions that had been decomposed with an excess of caustic potash he obtained by electrolysis a form of metallic lead that very easily became oxidized in the air with the production of the yellow crystalline oxide.

Certain of Schützenberger's results and his conclusions did not long remain unchallenged. Wiedemann<sup>2</sup> was unwilling to admit the existence of an allotropic modification of copper and brought to the French chemist's attention a paper published by himself as early as the year 1856. In this early communication,<sup>3</sup> Wiedemann described the electrolysis of neutral copper acetate solutions and the production of a peculiar bronze-like deposit at the cathode. The following interesting paragraph occurs in this article:

"The copper deposited at the negative pole takes with it a quantity of copper oxide from the solution, the deposit then becoming very brittle and dark brown. The amount of copper oxide held by this deposit is dependent upon the concentration of the solution."

At that time (in 1856) Wiedemann did not further investigate the nature of the copper deposit but after the announcement of Schützenberger's work he again took up his former study, obtaining somewhat different results from those of the latter chemist. Wiedemann's cathode films were invariably impure and contained, besides oxide of copper, very appreciable amounts of acetic acid.

<sup>1</sup> *Comptes rendus*, 86, 1397 (1878).

<sup>2</sup> *Wied. Ann.*, 6, 81 (1879).

<sup>3</sup> *Pogg. Ann.*, 99, 193 (1856).



Wiedemann performed several quantitative experiments in order to ascertain the relationship between the amount of current consumed and the mass of the substance or substances deposited by this current upon the cathode, as well as to determine the amount of the copper actually present in the deposit. He arranged three electrolyzing dishes in series, to wit—a silver coulometer, a saturated aqueous solution of cupric acetate and a weaker solution of the same salt. Platinum cathodes were used in all three cells. After determining the weight of the substance deposited from the acetate solutions by a given current (as indicated by the coulometer), each deposit was dissolved in pure nitric acid and its copper content determined. The data follow, with the calculated results:

(1) Number of the experiment	VI	VII
(2) Copper in solution in grams per cc	0.273	0.136
(3) Cathode deposit in grams	0.422	0.363
(4) Cathode deposit calculated in grams	0.263	0.263
(5) CuO equivalent to cathode deposit	0.473	0.422
(6) CuO calculated from (4)	0.329	0.329
(7) Excess of CuO in deposit	0.144	0.093
(8) Percent CuO adsorbed	35.3	25.4

Under (2) are given the concentrations of copper in the two acetate solutions. Under (3) are the actual weights of each cathode deposit; while (4) and (6) give the weights of copper and copper oxide required by Faraday's law, assuming all the copper to be in the divalent condition. (5) gives the amount of copper as oxide found by analysis in each cathode deposit. (7), obtained by subtracting (6) from (5), gives the excess of copper in the deposit, assuming it to be present as cupric oxide.

The numbers in this table indicate that there was deposited on the platinum cathodes decidedly more copper than was required by Faraday's Law. Assuming that the excess of copper was present as cupric oxide, it must have been extracted (adsorbed) from the electrolyte. The presence of cupric oxide in the deposit, noticed by Wiedemann in 1856, was thus confirmed.



As a result of his own experiments, Wiedemann was unable to accept the views of Schützenberger as to the allotropy of copper and explained the observed phenomena as being due to the presence of admixed cupric oxide in the deposit. He concludes with the following statement:

“Therefore the copper precipitated from the acetate solutions contains very definite amounts of cupric oxide and the more concentrated is the solution employed, the greater is the amount of copper oxide which the primarily deposited copper finds in its company.”

Schützenberger was not long silent. In reply<sup>1</sup> to Wiedemann he stoutly defended all his former statements and conclusions.

“Having with great care studied the chemical phenomena which accompany this electrolysis [of cupric acetate], I am convinced that the deposited copper enjoys special and characteristic properties which cannot be explained unless there is admitted the existence of a new and allotropic state of this metal.”

Wiedemann's deposits of copper were invariably rich in oxide but concerning this observation, Schützenberger wrote the following :

“At the beginning of my experiments, I obtained, as did M. Wiedemann, deposits rich in the oxide, but in following out my researches as I have specified to the Academy, I was able to reduce the proportions of the oxide to below five percent. . . . .

“The density is very much less than that which would result from a mixture of copper and copper oxide in the proportions furnished by his [Wiedemann's] analyses. Finally . . . all the properties mentioned disappear spontaneously when the allotropic copper is exposed to an atmosphere of oxygen or more rapidly, when heated to 100 or 150 degrees centigrade. The existence of an allotropic modification of lead and a red modification of silver . . . gives more weight to my conclusions.”

<sup>1</sup> Bull. Soc. chim. Paris, [2] 31, 291 (1879).

At this point the controversy ended and the subject was not again considered until in 1881, Mackintosh<sup>1</sup> disagreed with the conclusions of Schützenberger. He prepared the so-called allotropic copper and by analysis found that it contained appreciable amounts of carbon and hydrogen as well as of oxide and, as a result of his work and that of Wiedemann, concluded that Schützenberger's assumption of allotropy was unnecessary. He thus explained the peculiarities of the new form of copper: "The cause of the rapid oxidation . . . seems to be that the deposit is very porous."

For many years this question of the allotropy of copper was allowed to remain unsolved until it was again taken up in great detail by Carl Benedicks.<sup>2</sup> Benedicks checked Schützenberger's results and, in general, succeeded in corroborating them. He employed a rotating cathode and *acidified* cupric acetate solutions, so obtaining "acetate-copper" almost free from oxide. He thus described the deposits which he obtained.

"This 'acetate-copper,' as I have already shown, possessed all the properties of the allotropic copper, as for example, its marked tendency toward oxidation (blue tarnish when moistened), rapid evolution of nitrous oxide with nitric acid (dilute), low specific gravity, bronze-like color, etc. Hence the properties cannot be explained by the assumption of an admixture of cuprous or cupric oxide."

Benedicks also found that this "acetate-copper" invariably contained oxygen, carbon and hydrogen. The following are his analytical results:

Percent Loss in H <sub>2</sub>	C Percent	H <sub>2</sub> Percent	Acetic acid Percent	Excess O <sub>2</sub> Percent
1.58	0.248	0.052	0.62	0.96
2.86	0.441	0.075	1.10	1.76
2.84	0.688	0.107	1.72	1.12

<sup>1</sup> Am. Chem. Jour., 3, 354; Chem. News, 44, 279 (1881).

<sup>2</sup> Metallurgie, 4, 5, 33 (1907).

The above data were obtained by the analysis of deposits resulting from the electrolysis of approximately 0.7 normal copper acetate solutions containing from 1.2 to 2.4 percent of acetic acid.

As a result of his experiments, Benedicks advanced the theory that in the case of acetate-copper one was dealing with a solid solution of acetic acid in ordinary copper and not with an allotropic form of the metal. As an alternative he suggested that the acid might be present as a dispersed phase (colloidal suspension) in the solid copper, in other words, that acetate-copper was an "acetic acid cuprosol." In support of his idea of solid solutions he submitted the following experimental observations:

(1) Acetic acid is present in the deposit but the actual inclusions cannot be seen even with the most powerful microscopes.

(2) The specific volume of acetate-copper is less than that required by a mechanical mixture of acetic acid and copper in the proportions determined by analysis.

(3) A high electrical resistance, in one case eight times as great as that of pure copper, indicates wide-spread internal change. The conductivity is partially restored by heat. The data illustrating this point follow:

Resistance (micro-ohms per cm <sup>3</sup> ) of the acetate	
copper before heating was.....	14.4
After heating to 200° C.....	3.0
Resistance of pure copper.....	1.7

(4) The hardness of the deposit exceeds that of ordinary copper.

(5) A condition of internal strain causes spontaneous cracking and contraction, this being accompanied by the expulsion (sweating out) of small amounts of acetic acid.

(6) The formation of nitrous oxide by the interaction of dilute nitric acid on acetate-copper indicates a deep-seated internal change which cannot be due either to acetic acid or to copper oxide mechanically held by the deposit of copper.

#### Discussion of Previous Work

Benedicks' conclusions are decidedly vague. While the possibility of the existence of a solid solution of acetic acid in metallic copper is, *per se*, perfectly plausible, nevertheless the proofs adduced in its support are weak and inconclusive. The invisibility of acetic acid in the test portions of acetate-copper does not prove that the acid is in solution in the metal any more than the invisibility under the microscope of the individual particles of certain gold hydrosols proves that the latter are one-phase systems, *i. e.*, true solutions. The alternative of the cuprosol of acetic acid is interesting but one must admit that it is straining the point a great deal more than the facts necessitate.

The determination of the specific volume and the contraction so discovered is admittedly rendered of doubtful value by the experimental difficulties and need not be considered as highly important. The "sweating out" of small amounts of acetic acid and accompanying cracking and contraction of the deposit can be explained better by the theory that will be proposed than by postulating a very instable solid solution of acetic acid in copper. The formation of nitrous and not nitric acid *might* be a property of such a solid solution, but this behavior can hardly be brought forward as an indication of its actual existence.

The increased hardness and the decreased electrical conductivity remain as perhaps favorable to Benedicks' idea. But it must be remembered that the deposits studied by the latter were obtained under different conditions from those of Schützenberger. Benedicks' electrolyzed copper acetate containing *from 1.2 to 2.4 percent of acetic acid*; the other dealt with neutral solutions.

Wiedemann's objections to Schützenberger's statements were overcome by the latter's repeated investigations and the results of Benedicks. There remains no doubt but that deposits *almost* free from oxide may be obtained under certain conditions (rotating cathode, acidity, moderate concentration),

which exhibit all the properties described by the French scientist.

The major objection to Schützenberger's idea of allotropy lies in the fact that the copper deposit is *not pure* but invariably has been found to contain carbon, hydrogen and oxygen (probably as acetic acid) and small amounts of oxide. Allotropy postulates an internal change in a *pure substance* and, while, in the case under discussion, the copper in itself may or may not be in an unusual form (crystalline or amorphous, etc.) the assumption of allotropy as the explanation of the behavior of acetate-copper is unnecessary and meaningless.

J. Maxwell Garnett, in an interesting paper<sup>1</sup> upon the "Colors of Metal Glasses and Thin Films," quotes Roberts-Austen as thus defining allotropy. "The occurrence of metals in allotropic states... means that the atoms are differently arranged in the molecules." Schützenberger considered that the copper in the new form of the metal was present in a peculiar molecular form.

By heating or by contact with acids this instable molecule of copper was caused to polymerize with the evolution of considerable heat, and the polymer so formed corresponded to the ordinary form of the metal. Concerning this idea, Mackintosh<sup>2</sup> writes as follows:

"To account for the phenomenon of the spontaneous change of allotropic to ordinary copper in oxygen he frames the theory that allotropic copper corresponds to the copper of the cuprous [?] salts and that the molecular change is accompanied by development of heat. But we can see how liable to spontaneous oxidation such a large quantity of finely divided copper would be when it contained both carbon and hydrogen in a loose state of combination, and it is unnecessary to suppose the existence of another form of metallic copper to account for the phenomenon."

As I shall proceed to show that Schützenberger's allo-

<sup>1</sup> Phil. Trans., 205, 237 (1906).

<sup>2</sup> Loc. cit.

tropic copper was made up of particles of *normal copper in the colloidal condition* and hence in a state of extreme subdivision, it becomes at once evident that Mackintosh was on the right path. He recognized the fact that chemical reactivity is enormously influenced by surface phenomena and that in a substance of "great porosity" these become of very great magnitude, owing to the enormous surface development. Thus iron, released from its amalgam by the distillation of the mercury, readily burns in the air because of the great surface thus exposed to oxidation.

Mackintosh was also of the opinion that much of the increased activity of the copper was due to its holding in loose chemical combination both carbon and hydrogen. Such a combination does not exist and the mechanism by which these elements are held in the copper is governed by physical rather than by chemical forces (adsorption).

Mendeléeff<sup>1</sup> has described the results and conclusions of Schützenberger very inaccurately and was of the opinion that the modified form of copper was not allotropic but that it owed its unusual properties to occluded hydrogen or to the formation of a hydride. We will not discuss this statement further than to point out that Schützenberger himself showed fairly conclusively that such cannot be the case and that the small amounts of hydrogen present do not play an important rôle.

Schützenberger's allotropic copper shows a striking resemblance in nearly all its physical properties to the allotropic silvers prepared by Carey Lea.<sup>2</sup> By the reduction of silver tartrate with ferrous tartrate or of silver citrate with ferrous citrate, dextrine and other reducing agents, silvers were prepared which possessed very remarkable properties and existed apparently in many different and allotropic forms. By the first mentioned process in neutral or acid solutions, Lea obtained a form of silver<sup>3</sup> that "exactly resembled me-

<sup>1</sup> "Principles of Chemistry," 2, 404.

<sup>2</sup> Am. Jour. Sci., [3] 37, 38 (1899); 41, 42 (1891); etc.

<sup>3</sup> Ibid., [3] 41, 179 (1891).

tallic gold." A brief résumé of the more striking properties of the gold-colored silver will be given.

The deposit of metallic silver, after filtering and washing, was of a golden color and by further washing with water containing one percent of Rochelle salts changed to a reddish or coppery gold. The dried lumps of metal were lustrous and mirrors formed upon glass were, when dry, optically continuous. The allotropic metal was exceedingly brittle and pulverulent and, ground in a mortar, gave a fine powder of ordinary silver.

The yellow silver was readily transformed by the action of heat into the ordinary white form. Contact with mineral acids and with certain salt solutions caused a like transformation which was also readily induced by shock and the high tension spark discharge from a Leyden jar. The density was very much less than that of ordinary silver. The yellow allotropic silver invariably contained from two to five percent of iron, carbon and hydrogen and other impurities, depending upon the substances present during its reduction.

The extraordinary similarity between the yellow "allotropic" silver of Lea and the copper of Schützenberger will be made more evident by consideration of the physical properties of the latter substance. Its color was that of certain bronzes and it was exceedingly brittle and pulverulent. By contact with dilute mineral acids or with strong acetic acid it was slowly changed to the ordinary form of copper and this same transformation could be brought about by subjecting the substance to moderately high temperatures. The deposits of acetate-copper contained carbon, hydrogen and copper oxide as irremovable impurities. The density was abnormally low.

Lea's yellow silver was more active chemically than the ordinary form of the metal. In dilute hydrochloric acid the so-called "gold-colored allotropic silver" was changed to a mixture of normal "white" silver and silver chloride—a reaction which takes place only to a very slight extent with

fine filings of the normal metal. E. A. Schneider<sup>1</sup> entirely confirmed Lea's observation.

Benedicks' acetate-copper possessed a very low electrical conductivity, which could be increased very greatly by subjecting the metal films to heat, as we have seen on a previous page. But it was shown by Faraday<sup>2</sup> in the case of mirrors of colloidal gold, that such films of colloidal metals, though optically quite homogeneous, nevertheless offered extraordinarily high resistance to the passage of an electric current and hence must have been composed of innumerable small particles of metal in more or less imperfect contact. Barus and Schneider<sup>3</sup> measured the resistance of films of Lea's silver and found them non-conducting, or nearly so, because of the *great contact resistance between the particles*. The same phenomenon was studied by Lüdtkke<sup>4</sup> who found that the electrical conductivity *increased* as the mirrors were allowed to age, a very strong indication that in the course of time, the particles coalesce and reduce the contact resistance.

On heating gold-colored allotropic silver to 180° Centigrade Carey Lea<sup>5</sup> found that it was no longer easily pulverizable in a mortar. Heat has the same effect upon acetate-copper and the change is to be ascribed to the coalescence of the particles under the influence of heat.

A summary of certain of the points of similarity between the so-called allotropic forms of silver and copper will be given at this point.

(1) The color of the allotropic forms is distinctly different from that of the normal metal. The color of Lea's silvers may be almost anything depending upon conditions—yellow, golden or coppery colors predominate. Schützenberger's copper was brownish or bronze-like.

<sup>1</sup> Ber. chem. Ges. Berlin, 25, 1440 (1892).

<sup>2</sup> Phil. Mag., [4] 14, 407, 512 (1857).

<sup>3</sup> Zeit. phys. Chem., 8, 278 (1891).

<sup>4</sup> Wied. Ann., 50, 678 (1893).

<sup>5</sup> Am. Jour. Sci., [3] 41, 179 (1891).



(2) The *apparent* specific volume is in both cases greater than that of the normal metal; that is, the density is less.

(3) The electrical conductivity of the modified form is very much less than that of the ordinary form and is increased in both cases with age and heat.

(4) Both modified forms are easily reduced to an impalpable powder by grinding in a mortar.

(5) In both cases, the allotropic modification is converted more or less easily into the normal form by a variety of agencies, such as heat, light, ageing, contact with dilute acids and salt solutions and so forth.

(6) The chemical activity of both allotropic forms is very much greater than that of the ordinary metal.

It is now universally conceded that Lea's so-called allotropic silver owed its properties to its finely divided, colloidal condition and that the gold-colored form consisted, not of an allotropic modification, but of ordinary silver in the form of a hydrogel. In other words, *no molecular rearrangement had occurred within the silver molecule*—such a rearrangement being the only premise on which to base a condition of allotropy. Prange,<sup>1</sup> Barus and Schneider,<sup>2</sup> and later, Garnett,<sup>3</sup> all came to the same conclusion, substantially as outlined above.

"Allotropic" silver being colloidal and showing, in all respects, a perfect similarity to Schützenberger's allotropic copper, there can be but one conclusion concerning this latter substance. Allotropic or acetate-copper is an electrically deposited hydrogel of normal copper. We shall now proceed to further proofs in support of this hypothesis and to an elaboration of the idea in a somewhat unique manner.

It now becomes necessary to account for the formation of colloidal copper by the electrolysis of acetate solutions. An aqueous solution of copper acetate on standing or, more rapidly, when heated (cf. Schützenberger's directions) be-

<sup>1</sup> Rec. Trav. chim. Pays-Bas, 9, 126 (1890).

<sup>2</sup> Zeit. phys. Chem., 8, 278 (1891).

<sup>3</sup> Phil. Trans., 205, 237 (1906).

comes partially hydrolyzed with the production of an insoluble basic acetate or of cupric hydroxide.

A portion of this may be precipitated; the remainder will stay in suspension. On electrolyzing such a solution, if it contains a sufficient quantity of free acetic acid, the suspended hydroxide of copper will assume a positive charge, wander by cataphoresis to the cathode and there concentrate, it having been shown by Perrin<sup>1</sup> and confirmed by (as yet unpublished) work in this laboratory that oxides or hydroxides of the heavy metals suspended in *acid* solutions assume a positive charge and wander with the current to the cathode. Many of the organic emulsion-colloids behave in a similar manner and become positively charged in weakly acid suspension.

Müller and Bahntje<sup>2</sup> have confirmed these statements in a most conclusive manner by certain experiments upon the effect of organic colloids (emulsion-colloids) in the electrolysis of copper-sulphate solutions. They advanced the idea that copper, while being deposited at the cathode during electrolysis, is at first in a colloidal condition and, if a suitable protecting colloid be present, this condition will be maintained to a greater or less degree, depending upon the colloid employed in the solution. Thus copper, from sulphate solutions containing gelatine, has a structure indicative of very finely crystalline structure and has a low specific gravity because of the organic matter carried down with it during its formation.

Finally, unless the organic colloid is present at the cathode during the separation of the copper, no change in the appearance and structure of the metal can be detected.

The formation of colloidal copper by the electrolysis of copper acetate is due to the action of the inorganic colloid present in the solution and concentrating by cataphoresis at the cathode. The gelatinous copper hydroxide or basic acetate forms a "protecting" layer about each particle of copper and, by preventing the coalescence of these particles, maintains the metal in the form of a solid gel.

<sup>1</sup> Jour. Chim. Phys., 2, 601 (1904).

<sup>2</sup> Zeit. Elektrochemie, 12, 317 (1906).

Silver, again, furnishes us with interesting comparisons. Paal<sup>1</sup> prepared colloidal silver by the combined reducing and protecting action of prot- and lys-albinic acids, the albuminous substance forming the films about the metal particles. Hanriot<sup>2</sup> found that the oxide of iron present in Lea's golden silver formed an integral part of the silver molecules; in other words, present as the gelatinous hydrate, the iron plays a rôle exactly analogous with that of the albuminoid bodies present in Paal's silver.

Copper is not unique in forming a colloidal deposit at the cathode during the electrolysis of certain of its salts. Vogel<sup>3</sup> obtained a form of silver deposited upon a platinum cathode which tended to the formation of a colored powder (compare Lea's silvers). By the electrolysis of silver nitrate containing gelatine, Snowdon<sup>4</sup> obtained a yellow and a purple deposit of colloidal silver on a rotating cathode and his experiments have been repeated in the course of my investigations. The same experimenter, in this laboratory, has studied<sup>5</sup> the effect of gelatine upon the nature of the lead deposited upon stationary and rotating cathodes from lead acetate solutions and in every case the organic colloid *if it concentrates at the cathode*, causes the metallic deposit to assume a more or less finely crystalline or colloidal form.

In Schützenberger's electrolysis, no organic substance was added to the solution, the colloid, as has been stated, being a product of the hydrolysis of the electrolyte. That such a "protecting" colloid actually exists in the solution can be shown by the following interesting experiments.

It has been shown by Quincke,<sup>6</sup> Bechold, Pickering,<sup>7</sup> and others in the case of the well-known emulsions of oils

<sup>1</sup> Ber. chem. Ges. Berlin, 35, 2206, 2224 (1902).

<sup>2</sup> Comptes rendus, 137, 122 (1903).

<sup>3</sup> Pogg. Ann., 117, 316 (1861).

<sup>4</sup> Jour. Phys. Chem., 9, 392 (1905).

<sup>5</sup> Ibid., 10, 500 (1906).

<sup>6</sup> Cf. Freundlich: "Kapillarchemie," 459 (1909).

<sup>7</sup> Jour. Chem. Soc., 91, 2001 (1907); Zeit. Kolloidchemie, 7, 11 (1910).

in soapy water, that the oil is present as a highly dispersed phase in drops suspended in the water containing the soap. Each drop of oil is surrounded by a viscous film or membrane of soap, the attraction between the drops is reduced to a minimum<sup>1</sup> and a more or less stable and permanent emulsion is formed. The soap functions as a protecting colloid and by violently shaking an oil, such as kerosene or benzene, in water containing sodium oleate as the soap, emulsions may easily be obtained consisting of 99 percent by volume of benzene and 1 percent by volume of a one percent solution of sodium oleate.

With these results in view, we are justified in using the emulsification test, in the case of a pure substance such as benzene as an indication of the presence in a liquid of a protecting colloid. A positive test indicates without doubt that such a substance is present; a negative test, however, is of little value for the reason that many colloids do not act as emulsifying agents save under very special conditions.

The emulsification test for detecting the presence of a protecting substance in suspension was first applied to an aqueous solution of ferric acetate. Pure benzene was added to an approximately 5 percent solution of ferric acetate contained in a stoppered bottle and the whole vigorously shaken until an emulsion was formed. By adding the benzene in small quantities at a time and by thoroughly shaking after each addition, a product was finally obtained which had the consistency of blanc-mange, possessed an opaque brown appearance and could be kept without marked change of structure for at least a week. The product possessed all the properties of the typical emulsions of benzene formed in presence of soap (sodium oleate).

Obviously, the conclusions to be drawn from the above experiment are that an emulsifying substance is present in the ferric acetate solution and that this substance must be a product of the decomposition of the iron salt, for it is hard

<sup>1</sup> Cf. Donnan: *Zeit. phys. Chem.*, 31, 42 (1899).

to see how the acetate itself could so function. It is a well-known fact that the iron salts are strongly hydrolyzed in aqueous solution, with the production of a hydrated oxide of iron which possesses a marked tendency to remain suspended in the solution. By the dialysis of a freshly boiled and dilute solution of ferric chloride or by similar treatment of a more concentrated solution of ferric acetate, very characteristic, red suspensions of ferric oxide may be prepared with great ease. It is this gelatinous substance, suspended in the ferric acetate solution, that forms the films about the drops of benzene and gives rise to a typical benzene-in-water emulsion.

Having applied the emulsification test with such marked success to the case of hydrolyzed ferric acetate solutions, it was next employed as a measure of the "protecting" action of the hydrated copper oxide present in a copper acetate solution. As copper oxide shows a very much smaller tendency to remain in suspension than does iron oxide, it was expected that the emulsification of benzene would be only partial; such was the case when the experiment was performed. On shaking benzene with a five percent cupric acetate solution, however, a very distinct emulsion was formed, and the drops of benzene did not completely coalesce until several days had passed. While the test was not nearly so striking as that with the iron solution it was quite sufficient as an indication of the actual existence of a gelatinous "protecting" substance such as was postulated on a previous page. The results justify the statement that a gelatinous, colloidal oxide (or hydroxide) of copper exists in copper acetate solutions and that this undoubtedly exerts a definite effect in the solution, similar in every respect save that of magnitude, to the effect of iron oxide, sodium oleate or gelatine. The extraordinary action of gelatine furnishes the theme for the second part of this paper.

Since the mode of preparation and the great similarity to other established colloidal forms of metals make it evident that Schützenberger's acetate-copper was normal copper in the condition of a *hydrogel*, it remains only to show wherein some of the more peculiar properties of the substance serve

to further the above-mentioned hypothesis. Low specific gravity, low electrical conductivity, great brittleness and marked chemical reactivity are the usual accompaniment of a state of colloidal subdivision. The effect of strong mineral acids, very strong acetic acid and heat is to cause a coagulation of the particles and, as a result, conversion to normal "red" copper.

The presence of the very noticeable amounts of copper oxide in Wiedemann's deposits can be explained by three processes: (1) The oxidation of the deposit, (2) the adsorption of copper oxide from the solution, and (3) the presence of copper hydrate films about the copper particles. More will be said of this second important property in the second part of this paper.

The presence of acetic acid in the copper is due no doubt to its adsorption from the slightly acid solution and to its presence as basic acetate which may serve as the insoluble substance in the colloidal films. As the copper deposits age, we should expect a certain amount of change from the colloidal to the normal form of the metal, and this would certainly be attended by a volume-shrinkage. This accounts very well for the observations of Benedicks with regard to the cracking of the deposit and resulting expulsion of small amounts of acetic acid.

Under certain conditions the colloidal *gel* of copper is spontaneously changed to red copper with a considerable evolution of heat. Colloidal silver evolves considerable heat in changing to the normal white form.<sup>1</sup>

The peculiar action of this form of colloidal copper upon dilute nitric acid is a result of the extreme state of subdivision in which the metal exists. The reactivity being greatly intensified, it is but natural to find it combining with much weaker acid solutions than are able to bring about chemical reaction with ordinary copper. Normal copper gives a mixture of nitric and nitrous oxides (including nitrogen) when

<sup>1</sup> Prange: Rec. Trav. chim. Pays-Bas, 9, 121 (1890).

dissolved in nitric acid, nitric oxide largely predominating. But Sabatier and Senderens<sup>1</sup> have found that copper in the finely divided state is readily oxidized by nitric oxide and nitrous oxide is so formed. With ordinary sheet copper this reduction of nitric oxide does not take place. When "allotropic" copper was placed in dilute nitric acid a brown or black discoloration was seen by Schützenberger, which was probably cupric oxide produced by the reduction of the nitric oxide, at first formed. When sheet copper dissolves in the same acid, no brown layer is formed and nitric oxide is the chief product. Thus the nitrous oxide is formed by the reduction of nitric oxide by colloidal copper.

#### Summary

Schützenberger's "allotropic" copper has been described and the literature on the subject reviewed in detail.

The idea of "allotropy" held by Schützenberger and the "solid-solution" theory of Benedicks have been criticized and rejected.

By analogy with other known colloidal forms and by its behavior and preparation, the so-called allotropic copper has been shown to be a colloid hydrogel of the normal metal.

The formation of colloidal copper by the electrolysis of copper acetate solutions has been explained by postulating the existence in such solutions of a gelatinous, colloidal substance, probably copper hydroxide, formed by hydrolytic decomposition.

That such a "protecting" colloid actually exists has been shown by emulsification experiments with benzene.

Every property of Schützenberger's allotropic copper and Benedicks' acetate-copper can be explained on the basis of the above theory.

#### PART II—BLUE GELATINE-COPPER

Copper and the copper alloys such as brass and the bronzes lend themselves very readily to artistic decoration

---

<sup>1</sup> *Comptes rendus*, 114, 1429 (1892).

by means of colored superficial films or "patinas." Great as is the variety of hues which may thus be imparted to copper, it is a remarkable fact that a rich, permanent and true blue patina for this metal is practically unknown. It was while seeking such a blue surface film that the electrolysis of copper acetate solutions containing gelatine was first performed. One gram of gelatine was dissolved in about 325 cc of a one percent solution of cupric acetate and this mixture electrolyzed between carefully cleaned and burnished electrodes of sheet-copper. The electrolysis was allowed to proceed for about five minutes with a cathode (and anode) current density which varied from 0.15 to 0.45 ampere per square decimeter in the different experiments. The deposition was carried out at room temperature.

Great care was exercised in preparing the electrodes employed throughout the work, in order that they might be absolutely free from grease. The cleaning was done by first "pickling" the electrodes in warm caustic alkali solution and by following this treatment with a short immersion in nitric acid diluted with its own volume of water. After being thoroughly rinsed and dried, the electrodes were then burnished with a rotating burnisher until a fairly good polish was obtained.

The electrolysis performed, the cathode was found to be covered on its inner surface with a thin, pale brown deposit, which under the fingers possessed a peculiar slippery surface due, no doubt, to the deposition of a certain amount of gelatine with the metal. On prolonging the electrolysis for five minutes a noticeable amount of the gelatine was deposited at the cathode; indeed the film was no longer adherent and could be scraped off the surface of the electrode. No gas was given off at either pole.

In itself, this pale brown cathode deposit gave no indication of its peculiar properties, and it was by chance only that these were discovered. An electrode, freshly coated with a layer of the gelatine-copper, was by an oversight allowed to remain in the solution of copper acetate from which the film



of metal had just been deposited and the current was turned off. On removing the electrode from the solution, it was noticed that the brown color originally possessed by the cathode film had given place to a purplish blue of extraordinary brilliance and beauty. This led to further experiments.

A second electrode was then coated with gelatine-copper and, after careful rinsing in cold water, immersed in a five percent solution of cupric acetate. A most beautiful and startling phenomenon was the result. For straightway there ensued a remarkable series of color changes upon the surface of the copper deposit; hues of marked evenness and color-intensity followed each other in regular succession until the electrode had acquired a magnificent deep blue coloration. On continued immersion this blue color gradually faded to a pale blue or to an olive-green, after which no further changes were to be seen. This process we shall speak of as a "development," since it bears a certain resemblance to the development of the silver image in photography. The color changes occur in the following order:

1. Original pale brown
2. Golden brown
3. Reddish purple
4. Purple
5. Blue
6. Light blue
7. Final pale blue or olive-green

This color-development in copper acetate is an exceedingly beautiful phenomenon and can be stopped at any desired point by means of careful manipulation. The speed of the color-development increases rapidly with an increase in the temperature of the developing solution and varies under the influence of other and seemingly uncontrollable factors, of which more will be said later.

Of the colors mentioned in the table given above the blue is by far the most interesting. This color can be prepared of great purity and brilliance but unfortunately is exceedingly instable. In course of time when exposed to the air, the blue

patina loses its beauty and a pale blue-gray or a drab olive-green effectively hides all vestiges of the original splendid color. If the electrode, bearing its blue film, is heated in an air-oven at 180° Centigrade or is gently and cautiously warmed over a Bunsen flame the blue color is also destroyed and a peculiar greenish gray film (doubtless copper oxide) is formed. This latter film completely hides the normal copper color of the metal and has remained unchanged for over a year.

A "water-white" collodion lacquer was then applied to the blued copper with the hope that this would prove a cure-all for these troubles and effectually protect the delicate patina. But intense as is the blue reflection from the colored film, nevertheless the lacquer robbed it of much of its brilliancy and reduced it to a dull, paint-like coating of an indigo-blue shade. The lacquer possessed the added disadvantage of accentuating any *red* that might happen to be admixed with the blue.

The electrodes that have been covered with the "developed" film of gelatine-copper require the most careful treatment at all times. Careless handling with moist or soiled fingers is quite sufficient to ruin the beauty of the patina, and immersion in practically any salt solution leads to similar detrimental results. Dilute solutions of mineral acids and bases instantly destroy the blue color of these films and generally displace the blue with a more or less even shade of brown.

#### (a) The Effect of Gelatine—the Protecting Colloid

A 1 percent solution of cupric acetate *containing no gelatine* was electrolyzed under the conditions employed in preparing gelatine-copper. The cathode deposit was dark brown in color, possessed a granular structure and gave only traces of blue color-development in copper acetate. The deposit was identical with the "allotropic" copper of Schützenberger which we have discussed at length in the first part of this paper.

Gelatine in the required amount was then added to this acetate solution and the electrolysis repeated. The usual

pale brown cathode film was formed and the results on development were completely satisfactory. Gelatine was the determining factor in the process of the film formation.

The concentration of gelatine in the electrolyte was varied between fairly wide limits without any very striking results; there is, however, an optimum concentration of gelatine which will give the best results. The following summary of results show this:

1. With little or no gelatine the cathode deposits were identical with those of Schützenberger and were not developable to an even blue color.

2. If the concentration of gelatine lay between 0.25 and 0.66 percent the cathode films were even and translucent and developed a beautiful blue color in copper acetate.

3. If the gelatine exceeded one percent in concentration, the deposit was unsatisfactory and gave no development in copper acetate solution. In this latter case the gelatine migrated by cataphoresis to the cathode and was precipitated with the copper to such an extent that there resulted a non-adherent and sticky mixture of gelatine, copper oxide and metallic copper.

The rôle of gelatine in the process of forming these developable films was shown in a second and more interesting manner. Burnished copper and platinum electrodes were dipped in a hot, concentrated gelatine solution, and then dried. Thus treated, a portion of each electrode became coated with a hard, thin and perfectly transparent film of gelatine and the electrodes were then used as cathodes in a solution of cupric acetate *containing no gelatine*. They were immersed to such a depth that both the gelatine-coated surface and the clean, uncoated metal came in contact with the solution. After electrolysis, it was found that a brown, granular deposit of copper had formed on the free surface of the electrode and that this deposit was identical with the ordinary films obtained from gelatine-free solutions. On the other hand, on that part of the cathode which was covered with the gelatine layer, the usual film of gelatine-copper had been deposited and this

deposit, immersed in copper acetate developer, soon showed the usual blue color-reaction. The results, while not nearly so perfect as those obtained in the usual manner, nevertheless showed in a striking manner the importance of gelatine in modifying the nature of the cathode film.

Having become convinced of the important part played by gelatine in the process, we naturally expected a similar result with other colloidal substances. Starch and gum arabic were used but the results were negative; the copper film gave little or no blue color in the developing bath of copper acetate. In the case of soluble starch, a certain degree of development actually was noticed but it was not in the least comparable with that of gelatine-copper. Albumen, which might have given better results, was flocculated by the copper acetate electrolyte and could not be used.

It was thought that the failure of starch to give better results was due to the fact observed by Müller and Bahntje<sup>1</sup> that starch in copper sulphate migrated to the cathode only in strongly acid solutions and hence only under these special circumstances did starch modify the structure of their cathode deposits. Copper acetate was then made strongly acid with acetic acid, starch was added and the electrolysis performed. In the case of soluble starch the acid had a slightly beneficial effect, but the results were quite disappointing. Doubtless the acid, while causing a migration of the starch to the cathode, at the same time tended to coagulate the gel of colloidal copper and so, by its action on the metal, neutralized the advantage gained by its effect on the starch.

#### (b) The Effect of Temperature Variations

As already stated, the best results were obtained in the process by maintaining the electrolyte at room temperatures, or between 20 and 25 degrees Centigrade. By prolonged heating to temperatures above 60° C. the copper acetate solutions are hydrolyzed to a large extent and deposit basic

<sup>1</sup> Zeit. Elektrochemie, 12, 317 (1906).

acetates and oxides of copper. When a freshly prepared bath of acetate and gelatine was electrolyzed at 50° C. and with a current density (cathode) of about 0.3 ampere per square decimeter, the results were entirely different from those obtained at the lower temperatures. At first, a golden-yellow film spread out over the electrode but as the electrolysis proceeded, this gave way to a bright red or red-brown layer containing gelatine and cuprous oxide. Under certain conditions this layer could be peeled off from the body of the electrode and, by examination, proved to be highly translucent. After about ten minutes, the cathode was covered completely with a bright red layer; on longer electrolysis the red was displaced by brown. A second and freshly prepared acetate-gelatine solution gave, after five minutes' electrolysis on a water-bath at 85° C, a very beautiful salmon-pink film on a cathode of copper.

A one percent solution containing one-half percent of gelatine was then electrolyzed with the exceedingly small current density of 0.1 ampere per square decimeter and at 57°-60° Centigrade. After ten minutes the cathode had received a very beautiful shade of gold. At temperatures above 60° C the gold became distinctly redder and if the electrolysis was continued for an hour or so, a splendid red coloration was the result. None of these gold, salmon-pink or red films are affected in the least by attempted development of copper acetate solutions.

These results may be summed up as follows: Up to 35° C or thereabouts, electrolysis of copper acetate-gelatine solutions gives a brownish film of copper at the cathode which develops a blue surface coloration in copper acetate solutions. Under the same conditions of time and current density, at temperatures between 50° and 90° the cathode deposit is red in color and does not lose this color by development in copper acetate. With very low current densities and at temperatures lying between 55° and 60°, a short electrolysis gives a golden-colored film, while longer electrolysis leads to the red modification. As the acetate is hydrolyzed and the gelatine decomposed

by prolonged heating, the colors of the cathode film become less beautiful and brown colors predominate.

These red deposits can be lacquered and when so preserved have kept their color unchanged for over a year. The golden-colored sheets become brownish gold on standing and then exhibit an iridescent appearance, the golden color being perhaps the result of thin-film colorations (cf. Nobili's rings).

(c) **The Nature of the Electrolyte**

There now arose the question as to whether or not other copper salts could be employed in this electrolysis in place of the copper acetate that had been used up to this time. Accordingly one, two and five percent copper sulphate pentahydrate solutions were prepared and gelatine added in varying proportions. The results upon electrolysis presented nothing striking; the deposit was copper in its usual form with a more or less burnished appearance (due to its finely crystalline structure) and not the least trace of blue development in either copper acetate or sulphate solutions was noticeable.

A two percent solution of copper formate containing gelatine was next used and a light brown cathode deposit resulted. This film underwent a fairly good development in both copper formate and acetate, but the effects were less satisfactory than those obtained with the acetate solutions.

Copper propionate was then prepared by decomposing copper carbonate with hot aqueous propionic acid, filtering the blue liquid thus obtained so as to remove the excess of carbonate, and allowing the copper propionate to crystallize out on cooling and slow evaporation. Using one percent solutions of copper propionate with gelatine, a cathode deposit was formed which was similar in every respect to the gelatine copper obtained from the acetate solutions. All the films developed a good, even, blue shade in copper propionate and acetate solutions.

Copper glycollate was prepared from the carbonate and glycollic acid but, owing to its slight solubility in water, negative results were obtained.

Copper chloride and nitrate gave results similar to those with the sulphate; it is thus necessary to use the copper salts of the lower fatty acids to obtain developable gelatine-copper films.

**(d) The Concentration of the Electrolyte**

Returning once more to the use of acetate solutions it was discovered that the best results were obtained with one or two percent solutions of the copper salt. Very dilute solutions, caused a troublesome evolution of hydrogen at the cathode; saturated solutions gave rise to dark brown, non-adherent deposits.

**(e) Duration of the Electrolysis**

Under the standard conditions previously determined and described, five minutes was sufficient time for the preparation of a satisfactory deposit. Prolonged electrolysis caused the copper to blacken and to become heavily coated with gelatine concentrating at the cathode.

**(f) Effect due to Acidity of Electrolyte**

When acetic acid was added to the electrolyte, it was found that the films became lighter in color and gave poorer blues on development. With strongly acid solutions the development became very slight indeed. The electrolyte should be neutral or contain but a slight excess of free acetic acid.

**(g) The Nature of the Cathode**

The nature of the metal used as cathode is of little importance in this process as long as it does not in itself cause the decomposition of the copper solution. Thus, with nickel, brass and platinum good deposits of gelatine-copper were obtained and all these gave good blue colorations upon development.

**Quantitative Experiments**

The electrolysis of copper acetate solutions containing the usual quantity of gelatine was next carried out with a

carefully measured current and with carefully weighed electrodes. A copper coulometer was placed in series with the acetate cell and, using Faraday's law as the basis of computation, the cathode efficiency was determined. The solution employed contained 1.5 percent of crystallized cupric acetate and 0.6 percent of gelatine. The experiments were performed at room temperatures, the developments at 30°–35° C.

## (a) WITH A CATHODE OF SHEET-COPPER

Coulometer gain Gram	Test cathode gain Gram	Efficiency Percent	Weight change on de- velopment Gram
0.0198	0.0231	117	+0.0008
0.0125	0.0160	128	—
0.0203	0.0283	139	—0.0043

## (b) WITH A CATHODE OF SHEET-PLATINUM

Coulometer gain Gram	Test cathode gain Gram	Efficiency Percent	Weight change on de- velopment Gram
0.0251	0.0340	131	—0.0047
0.0313	0.0376	120	—0.0007
—	0.0140	—	—0.0005

The numbers in the first column are the weights in grams of the copper deposited upon the coulometer cathodes while those of the second column show the corresponding gain by the test-cathodes in the acetate solution. The cathode efficiency is shown in the third column and the changes in weight occasioned by careful development of the test cathodes constitute the fourth column.

It is evident from the data so obtained that the deposit from the gelatine-acetate solution is distinctly abnormal. The high efficiency calculated for the cathode deposition is, of course, meaningless as the deposit was certainly contaminated with *gelatine*, oxide, acetic acid or copper acetate.



After electrolysis the gelatine was present upon the deposit in a visible layer and was removed by careful rinsing in cold water before the electrode was weighed.

The weight changes upon development are small and show nothing. The high loss in weight in two experiments (over four milligrams) may have been due to incomplete removal of gelatine from the electrodes before they were weighed to determine the cathode efficiency.

These experiments are vitiated by the errors met with in handling such small quantities of a very instable substance, possessing enormous surface and an undoubted tendency towards oxidation and the adsorption of cupric oxide and gelatine.

#### **The Development of the Blue Color**

We have seen that the copper deposited by the electric current from certain copper solutions containing gelatine possesses the striking property of developing a remarkable blue coloration in aqueous solutions of these same copper salts. This development is equally good in both acetate and propionate solutions while the formate gives a decidedly less satisfactory result, the blue color being duller, thinner and less evenly distributed over the surface. The presence of gelatine in the developing solution is of no effect and plays no discoverable part in the rather mysterious process of development.

*The effect of temperature* upon the rate of development was then studied. The cathode films were prepared under constant conditions and were then developed in saturated copper acetate solution at various temperatures. The development was continued until the same shade of blue was visible upon each copper electrode and the time required for this to occur was determined with a stop-watch. Electrolyte A contained 3 grams of copper acetate, 1 gram of gelatine and 325 cubic centimeters of distilled water. Electrolyte B contained 4 grams of acetate, 1 gram of gelatine and 325 cubic centimeters of distilled water. The data follow:

## COPPER FROM ELECTROLYTE A

Temp. of developer	Time required
17.5° C	420 sec.
20.0° C	180 sec.
24.0° C	110 sec.
28.0° C	65 sec.
31.0° C	50 sec.
34.0° C	40 sec.

## COPPER FROM ELECTROLYTE B

Temp. of developer	Time required
23° C	300 sec.
28° C	140 sec.
33° C	90 sec.
38° C	60 sec.
45° C	40 sec.

These data show that the rate of development increases very rapidly with a rise in the temperature of the developing solution. They also make prominent the fact that very small differences in the concentration of the electrolyte apparently have a marked effect upon the reactivity of the gelatine-copper. Indeed, films prepared under seemingly identical conditions oftentimes have displayed extraordinary differences in rate and nature of development in the same acetate developer. The experimental conditions are not easy to control.

The concentration of the developer has an uncertain effect, good development being obtained in both weak and strong solutions of acetate. With weak solutions the development is rapid but gives rise to thin and uneven colors. A five percent solution has usually been employed in this work.

The nature of the salt employed as a developer was next studied. A very great number of salts were used in aqueous solution but in no instance was a blue development noticed except in the following cases. Normal copper sulphate solution was carefully neutralized with ammonium hydroxide and used as a developer for gelatine-copper deposited from

an electrolyte made up of 325 cubic centimeters of 1.5 percent copper acetate and 1 gram of gelatine. A blue-black coloration ensued and the film on immersion in warm dilute hydrazine hydrate gave distinct evidences of the presence of copper oxide. With an eighth normal solution of copper sulphate the development was better and a dull but distinctly blue color was obtained from the warm solution. A control experiment with 5 percent copper acetate gave a magnificent blue. A mixed developer of 50 cc of  $N/5$   $K_2SO_4$  and 50 cc of 5 percent copper acetate gave a much duller and darker color.

These experiments show that development of gelatine-copper does occur to a limited extent in copper sulphate solutions.

In fiftieth normal sulphate developer the blue color was fairly bright and evenly distributed, although the development required the high temperature of  $45^{\circ}$ – $50^{\circ}$  C. In none of the experiments with sulphate developers, however, were the gorgeous colors of the acetate developers obtained.

The failure of the sulphate solution to give the best results must be ascribed to the presence of the  $SO_4$  ions and perhaps a trace of free  $H_2SO_4$ . This is borne out by the fact that the mixed potassium sulphate-copper acetate gave results little better than those obtained with copper sulphate, while potassium acetate had little effect upon copper acetate developer in retarding the coloration. Previous treatment of the film of gelatine-copper with very dilute  $H_2SO_4$  also prevented the formation of the blue patina.

Fifth normal copper nitrate at both room temperatures and at  $40^{\circ}$  C gave a black surface coloration to the copper film. In this case it is certain that the nitrate acted as an oxidizing agent, and that nothing more than brown or black cupric oxide resulted. Copper chloride gave no blue development.

Sodium and potassium acetate solutions of various concentrations gave not the smallest trace of blue surface colors nor did solutions of acetic acid alone. Hence we cannot

ascribe the color development to the acetate anions of the copper acetate --a copper salt is essential.

But is the blue color the result of an oxidation process? Various oxidizing solutions, such as potassium dichromate, permanganate, perchlorate, chlorate and persulphate, were employed as developers without the formation of a trace of blue color. A dirty brown discoloration of the film was the usual result, especially if the solutions were warmed to 50° C. A series of hydrogen peroxide solutions with a wide concentration range also afforded no indications of development. We are thus assured that the blue coloration is not simply and solely an oxidation process.

Reducing solutions gave negative results. The film of gelatine-copper was unaffected, by dilute, warm, hydrazine hydrate solution and underwent accelerated blue development in copper acetate after such treatment.

Contact with dilute solutions of mineral acids decreased the activity of the gelatine-copper toward copper acetate developer. About one-half of the surface of a film of gelatine-copper was immersed for a short time in tenth normal hydrochloric acid, the treatment resulting in a slight cloudy discoloration of the clear brownish layer. The whole film was then immersed in the usual copper acetate developer. A bright even blue color developed upon the surface that had not been treated with the hydrochloric acid; wherever the acid had been in contact with the deposit the developments were poor and uneven.

In stronger hydrochloric acid solutions the deposit took on a yellow-brown color which on standing, even under a collodion lacquer, became iridescent in appearance. Stronger nitric acid solutions turned the deposit into a non-adherent dark brown form while solutions of arsenic trioxide gave rise to an almost black coloration.

All of these observations make it evident that the gelatine-copper is very sensitive indeed to the action of almost any substance and solution but that the blue color-reaction can

be brought about only in solutions of copper acetate, propionate or formate or to a less degree in dilute copper sulphate.

#### **Reverse Development in Hydrazine Hydrate**

An electrode, covered with a layer of the deep blue copper, was immersed in a cold and dilute solution of hydrazine hydrate (5 to 10 drops of  $N_2H_4OH$  in 100 cc of water). In a short time bubbles of nitrogen began to rise from the blue surface and the color commenced to fade away, giving place first to a purplish red and then to a red. A golden brown color then overspread the surface until finally this disappeared and there was left the pale brown of the undeveloped gelatine-copper film. Indeed, this series of color changes was about the *reverse* of that exhibited during the usual process of development and will be termed "*reverse development*."

After the reverse development was completed, the electrode was rinsed in distilled water and once more immersed in copper acetate developer. The usual series of color changes occurred, the final product being a fairly good blue in color, even though a bit thin and uneven.

Further experiments in this direction led to the conclusion that in the powerfully reducing hydrazine solution the usual development could be reversed. The gelatine-copper so treated retained to a greater or less extent its property of turning blue in copper acetate. The obvious conclusion to be drawn from these experiments is that the process of *reverse development is a reduction*. This point is of prime importance in this investigation as it leads to an explanation of these phenomena which will be advanced later.

#### **Effect of Oxidation**

It was observed early in my experiments that a deposit of gelatine-copper, if dried and allowed to stand for an hour or longer exposed to the oxygen of the air, deepened slightly in color and *completely lost its power of developing the blue color in copper acetate solutions*. The colloidal, finely divided structure of the film being recognized, this striking decrease in activity was attributed to the "ageing" or coagulation

that colloid gels undergo upon standing and dehydration. In the case under discussion, however, while the "ageing" of the gel must be a factor, it is quite probable that the loss of developing power is due to the *oxidation of the copper deposit*. This conclusion resulted from the following experiments:

A deposit of gelatine-copper was prepared in the usual manner and allowed to remain untouched for about fourteen hours. It was then treated with the acetate developer without the slightest color change and without any visible surface or internal change. On rinsing in water and immersing the electrode in dilute, cold hydrazine hydrate solution a very decided evolution of gas, presumably of nitrogen, took place from the surface of the deposit. The reduction completed, the clean electrode was dipped into copper acetate with an almost immediate development of a bright blue color. The power of development had been restored to the inactive gelatine-copper by the reducing action of the hydrazine. On standing in the air the film of copper became transformed to cupric oxide and lost its power of development.

A second electrode was coated with the copper film and treated with warm dilute hydrogen peroxide solution. The film turned a dirty brown and would not develop blue in copper acetate. The electrode was then dipped in hydrazine solution until no further reduction occurred, *i. e.*, until the gas evolution ceased. On placing the film once more in the acetate developer, the copper deposit was given a fairly good, though uneven, blue color, showing, as before, that the power of development had been restored by the reducer.

#### The Structure of the Films

It now remained to investigate the structure of the blue film formed by development. Owing to the very small quantities of substance deposited at the cathode and the impurities undoubtedly present, an analysis of the deposit was not made and would have shown little if it had been made. A microscopic examination of the blue surface by reflected light

revealed little save that the color was fairly continuous and homogeneous.

A sheet of platinum was coated with an exceedingly thin film of vaseline and the usual layer of gelatine-copper deposited. A fairly good blue was obtained on development. After being dried, the film of colored copper was easily removed from the platinum in little flakes, blue on their external surfaces but possessing a bright copper reflection from the surfaces that had been in contact with the platinum. On being pulverized, a dark indigo powder was obtained. The coloration thus exists chiefly upon the surface of the films and not throughout their whole mass.

#### **Summary of Experimental Results**

The electrolysis of solutions of copper propionate, acetate and formate in the presence of gelatine gives rise to a peculiar form of copper at the cathode.

This gelatine-copper, on immersion in certain copper solutions, undergoes a striking "development" with the formation of a series of colors, blue being the most characteristic.

Evidences of development are given by dilute copper sulphate solutions, moderate development by copper formate and good development by solutions of copper acetate and propionate.

The blue coloration is due neither to a reduction nor to an oxidation of the gelatine-copper film. By oxidation the deposits lose their power of giving the color-reaction; by reduction in dilute hydrazine this power is restored. Oxidizing and reducing agents destroy the blue color of the developed films and the same result is obtained by dilute acids, alkalies and salt solutions as well as with heat, ageing and other means. In dilute hydrazine hydrate a blue film undergoes a reversal of the development.

The blue seems to be largely a surface coloration.

Under special circumstances, a red, brown or gold color can be imparted to copper, brass or platinum by making these

metals cathode in copper acetate solutions containing gelatine.

### PART III—CONCLUSION

#### Gelatine-copper

In the first part of this paper it has been shown that the "allotropic" copper of Schützenberger was the normal metal in the modified physical form of a *colloidal gel*. The formation of such a gel was ascribed to the action of the gelatinous, hydrous copper oxide suspended in the acetate electrolyte.

The second part of the paper dealt with the production of a similar deposit of copper upon the cathode during the electrolysis of copper acetate containing gelatine. To return again to the paper of Müller and Bahntje, it was shown that the presence of certain colloid bodies in copper solutions undergoing electrolysis may have a marked influence upon the copper deposited. The formation of the copper deposit is a cathodic process and, as a result, it is essential that the colloid substances should be present in appreciable quantities in the region of the cathode if they are to exert any influence upon the structure of the copper film. The direction of migration (cataphoresis) of the colloid particles must hence be *from the anode to the cathode*; if the reverse is the case, the colloid has little influence upon the cathode deposit. In neutral copper sulphate solutions starch did not concentrate upon the cathode and did not affect the copper being formed there; but in more strongly acid solutions the starch moved to the cathode and modified the structure of the metal film. Gelatine, however, in solutions containing a trace of free acid, moved to the cathode and there exerted its peculiar influence.

Copper formed by electrolysis from sulphate solutions containing gelatine has a burnished appearance, the result of the very finely crystalline nature of the deposit. This is due, say Müller and Bahntje, to the so-called "protective" action of the hydrophile colloid upon the metal particles, inhibiting the growth of the copper nuclei into larger aggregates.

The rôle of gelatine in copper acetate solutions submitted



to electrolysis is similar to that played by gelatine in copper sulphate. In this case the copper comes out in an intensified colloidal form and does not give the least indication of crystalline structure. There is thus formed a compact, irreversible gel of finely divided copper, containing gelatine and other adsorbed impurities.

#### **The Development**

To what is the blue coloration of gelatine-copper in copper acetate due? The answer to this question was not easy to find and was obtained mainly by a process of elimination.

That the blue color is not the color shown by thin films is proven by the uniformity of the blue color upon uneven surfaces. Thus a coin or an embossed copper dish can be colored a very even blue by the application of the process. No iridescent effects are noticed. Examination of the blue surface under a microscope by light reflected upward from the surface, reveals the homogeneity of the colored film.

Since the blue color is formed chiefly upon the surface of the copper deposit, it seems reasonable to exclude the possibility of a definite chemical reaction occurring between the gelatine-copper and the developer. If a chemical reaction were actually taking place we should be able to obtain equally good development in either the acetate salts of other metals or in other copper salts, such as sulphate, chloride, nitrate, etc. If a chemical reaction occurred, the whole cathode deposit would doubtless be converted into a blue layer with a distinct increase in weight, the reaction being necessarily between the copper in the cathode film and the copper as ion or the copper acetate itself. The change in weight of the film on development is small and uncertain, and at present gives little indication of the actual changes that may occur.

It will be recalled that Wiedemann noted, in the case of the so-called allotropic copper, that it possessed the power of absorbing copper oxide from the solution of acetate from which it had been prepared. This observation, discussed in the first part of this paper, leads directly to a most plausible explanation of the development phenomenon. The hypothesis

is this: the color changes that take place on the surface of the gelatine-copper film during immersion in the developer are due to a surface adsorption by the colloidal copper of hydrous copper oxide or hydroxide from the solution. As already explained, the copper hydroxide is formed by the hydrolysis of the copper salt and is present in suspension to a greater or less degree depending upon the nature of the copper salt employed as developer. The weaker the acid combined with the copper the greater the degree of hydrolysis; thus the sulphate solutions are much less hydrolyzed than the formate and the latter is still less hydrolyzed than the acetate and propionate. The development may be considered as dependent upon the concentration of oxide or hydroxide in the developer; we should thus expect little development in sulphate solutions, better development in formate solutions, and the best results in either copper acetate or copper propionate. This prediction is confirmed by the experimental facts.

These blue adsorption compounds of colloidal copper and copper oxide are analogous to the familiar adsorption compound of stannic oxide and gold known as the "Purple of Cassius." Silver in suspension forms a similar compound and of late years the idea has gained credence that the different "ultramarines" are similar adsorption compounds containing sulphur or are solid suspensions of sulphur in sodium aluminate, borate and other bodies.<sup>1</sup>

The reversal of development by hydrazine is due to the reduction of the copper hydroxide adsorbed by the colloidal copper, the latter being restored to nearly its original condition. The redevelopment that can then be brought about in copper acetate is a repetition of the regular process of development.

There seems to be a certain definite ratio of hydroxide to copper in the surface film in order that the color reflected shall be blue. As the concentration of the adsorbed hydroxide

---

<sup>1</sup> Cf. Hoffmann: *Zeit. Kolloidchemie*, 10, 275 (1912).

increases, the color changes from brown to gold, to red and finally to blue. Long treatment with the developer seems to dissolve the deposit and either a pale blue-gray or a pale olive-green is the final shade obtained. On standing either exposed to the air or protected by a lacquer, the blue film probably loses water and then assumes the pale olive-green color of a thin film of copper oxide.<sup>1</sup>

Much work remains to be done in this most interesting field both in establishment of the above hypothesis as to the color effects and in finding a method of applying these colors to practical needs. At present the blue colors are instable to an extreme, and no lacquer has yet been found sufficient for their protection. It is hoped that further work will throw light on the subject.

The general results of this paper are the following:

Schützenberger's "allotropic" copper is a solid gel of normal copper in a finely divided form, analogous with similar forms of lead, silver, and gold.

The electrolytic production of a new form of colloidal copper by the electrolysis of certain copper solutions containing gelatine has been described in detail.

The remarkable color action shown by these films of gelatine-copper has been studied and termed a development.

The development seems to be an adsorption by the copper film of hydrous copper oxide (hydroxide) formed by the hydrolysis of the developing solution.

Electrolytic methods have been devised for coloring objects of copper and other metals a variety of hues, the more prominent being blue, red and gold.

This work was carried out under the direction of Professor Bancroft, and I wish to thank him for his interest and kindly criticism.

*Cornell University*

---

<sup>1</sup> Cf. Turner: Proc. Roy. Soc., 81A, 301 (1908).

## A NOTE ON THE STRUCTURE OF ACETYLENE

BY ALBERT P. MATHEWS

From a study of the volume of liquid acetylene, MacIntosh<sup>1</sup> concluded that acetylene was in reality acetylidene since one of the carbon atoms seemed to have the volume of bivalent carbon. He supported this contention also by various chemical arguments. On the other hand, Nef,<sup>2</sup> while showing that the halogen substitution products were in reality acetylidene compounds, believed that acetylene was acetylene and not acetylidene, because it was chemically and physiologically so inert. Nef's pupil, Lawrie,<sup>3</sup> confirmed the acetylidene nature of the bromine and iodine substitution products.

Although it is improbable, for the reasons stated by Nef, that acetylene is acetylidene, the matter may be definitely settled by my method of<sup>4</sup> determining the number of valences in the molecule from the molecular cohesion. If it is acetylene there should be ten valences; if acetylidene, there should be eight, since acetylene does not associate and one carbon atom would be bivalent.

The most recent determination of the critical data of acetylene by Cardoso and Baumé gives  $T_c$ , 35.5° C; and  $P_c$ , 61.6 atmospheres. From these figures the value of "a" of van der Waals' equation calculated by the formula:  $a = 27T_c^2/64 \times 273^2 \times P_c$ , is 0.008745. Computing the number of valences,  $n$  from "a" by the formula:  $n = a^{3/2} \times 3.2 \times$

<sup>1</sup> MacIntosh: "The Physical Properties of Liquid and Solid Acetylene," *Jour. Phys. Chem.*, 11, 315 (1907).

<sup>2</sup> Nef: "Ueber das zweiwertige Kohlenstoffatom," *Liebig's Ann.*, 298, 332 (1897).

<sup>3</sup> Lawrie: "Constitution of Acetylidene Compounds," *Am. Chem. Jour.*, 36, 487-510 (1906).

<sup>4</sup> Mathews: "The Relation of the Value 'a' of van der Waals' Equation to Molecular Weight and the Number of Valences of the Molecule," *Jour. Phys. Chem.*, 17, 181 (1913).

$10^6$ /(Mol. Wt.), we obtain the value 10.06 for  $n$ . There are, therefore, ten valences in the molecule of acetylene; accordingly each carbon has four, each hydrogen one.

Acetylene is, therefore, acetylene, as it is ordinarily written, and not acetylidene.

*University of Chicago*

## SOME TESTS OF THE EDISON STORAGE BATTERY

BY C. W. BENNETT AND H. N. GILBERT

The Edison battery, as developed by the Edison Company, is an extremely important addition to electrochemical apparatus. This is realized when it is remembered that the equivalent of about 300,000, 150 ampere-hour cells are being used to-day. The performance and properties of this battery have been studied exhaustively by the Edison Company only. A few of the papers<sup>1</sup> which have appeared in the literature on this subject may be referred to. These have dealt with the manufacture, details of construction, and performance of cells operating at normal rates. In view of the fact that this information is meagre, it was thought that measurements from a different standpoint, made by different workers, would be of value.

For these measurements, a battery of four cells was loaned the department of physical chemistry by Dr. E. W. Brown, P.A. Surgeon, U. S. N. The battery being available only for a short time, it was decided to run a few efficiency tests at different rates of discharge, study the effects of charging at different rates, check the measurements of capacity, and study the cell operating at a low temperature.

The cells used were the standard type, A8, 300 ampere-hour cells, normal charging and discharging rates, 60 amperes. The cells were connected in series.

<sup>1</sup> Kennelly: *Trans. Am. Inst. Elec. Eng.*, 18, 219 (1901). Roebber: *Elec. World and Eng.*, 37, 367 (1900); 38, 931 (1901). Marsh: *Elec. World*, 39, 996 (1902). Hospitalier: *L'Industrie Electrique*, 12, 493 (1903). Jungner: *Electrochem. Ind.*, 1, 258, 465, 508 (1903). Schoop: *Ibid.*, 2, 272, 310 (1904). Silg: *Ibid.*, 3, 237 (1903). Jououst: *L'Eclairage Electrique*, 38, 201 (1904). Hibbert: *Jour. Inst. Elec. Eng.*, 33, 203 (1904). Joly: *Ibid.*, 33, 226 (1904). Kennelly and Whiting: *Trans. Am. Electrochem. Soc.*, 6, 135 (1904). Thompson and Richardson: *Ibid.*, 7, 95 (1905). Elbs: *Zeit. Elektrochemie*, 11, 734 (1905). Zedner: *Ibid.*, 11, 809 (1905); 12, 463 (1906). Faust: *Ibid.*, 13, 161 (1907). Foerster: *Ibid.*, 13, 414 (1907). Holland: *Electrician*, 68, 165 (1911). Montpellier: *Lumière élec.*, 16, 244 (1911). Lyon: *Jour. Ind. and Eng. Chem.*, 3, 922 (1911). Schneckenberg: *Elektrochem. Zeit.*, 19, 1 (1912).

In order to obtain these data in the course of the short time which the cells were at our command, it was decided to charge the cells until the voltage had remained practically constant on the highest part of the curve, for one hour. This was, therefore, called a complete charge, instead of the seven hours' run at 60 amperes, as recommended by the Edison Company. The battery was, therefore, completely charged, and then discharged at the desired rate until the voltage on closed circuit was 0.7 volt per cell. The amount of energy necessary to bring the battery back to the original voltage was taken as the proper input for the calculation of efficiency.

Recording meters were used and the mean voltage obtained from the equation

$$r = \sqrt{\frac{2a}{\alpha}}$$

where  $r$  = mean radius measured on a chart, which of course corresponds to the mean voltage,  $a$  = area of the sector

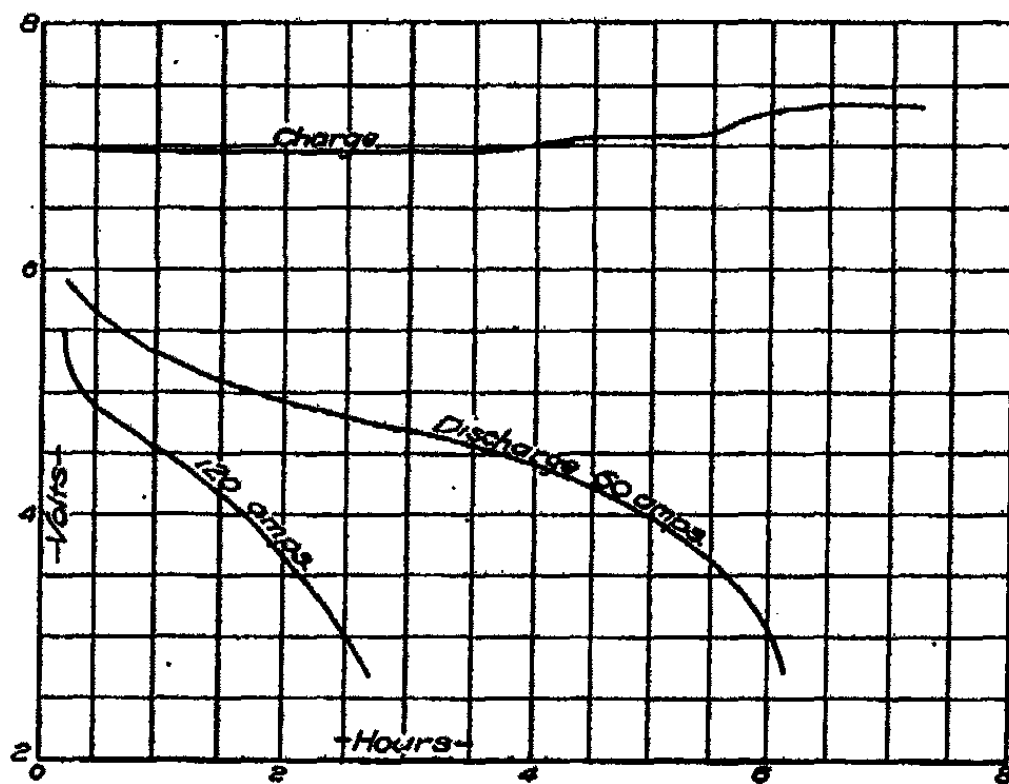

Fig. 1

bounded by the voltage time curve, and the radii extended to the center of the chart, and  $\alpha$  = the angle in radians, which was subtended by the time-voltage curve. The area was ob-

此圖係根據本報所載之試驗結果繪成者，其內容與原文無異，惟因篇幅所限，未能將圖中所有之數據一一標出，特此聲明。

tained by a planimeter, the angle being measured in degrees. The current of course was constant. The meters were carefully calibrated, and the errors introduced minimized as much as possible.

For comparison, Fig. 1 shows curves for charge and discharge at 60 amperes and one discharge at 120 amperes. For the normal charge it is seen that the average voltage is about 7 volts for the battery, the average discharge voltage being 4.5 volts, or 1.12 per cell. It is seen that the voltage continuously decreases, upon discharge. The actual figures for curves A and B are as follows:

TABLE 1

		Percent
Ampere-hours input	410	—
Ampere-hours output	350	—
Ampere-hour efficiency	—	85.4
Watt-hour input	2874	—
Watt-hours output	1589	—
Watt-hour efficiency	—	55.3

It has been stated that the Edison battery is capable of operating at high rates. No actual figures however are available as to what energy efficiencies or capacities are obtained under these conditions. The figures given below are not extremely accurate for they only represent one measurement each. They do, however, give an idea of what may be expected from these cells. Below are given efficiencies for four rates of discharge, the charge being normal. The output of the four cells is also given.

TABLE 2

Discharge rate in amperes	Average voltage	Watt-hour efficiency Percent	Output	
			Ampere-hours	Watt-hours
60	4.55	55	350	1593
120	4.30	53	260	1118
200	3.80	38	225	855
270	3.50	32	180	630



The decrease in efficiency as well as capacity is seen from curves in Figs. 2 and 3. From these figures it may be concluded

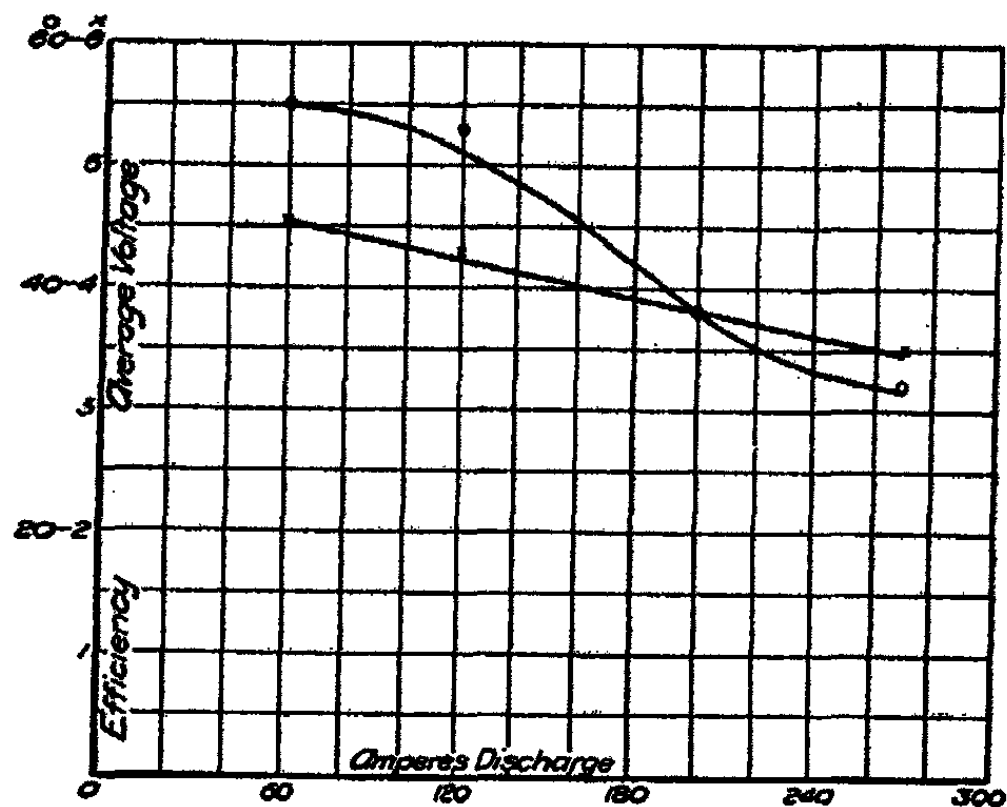

Fig. 2

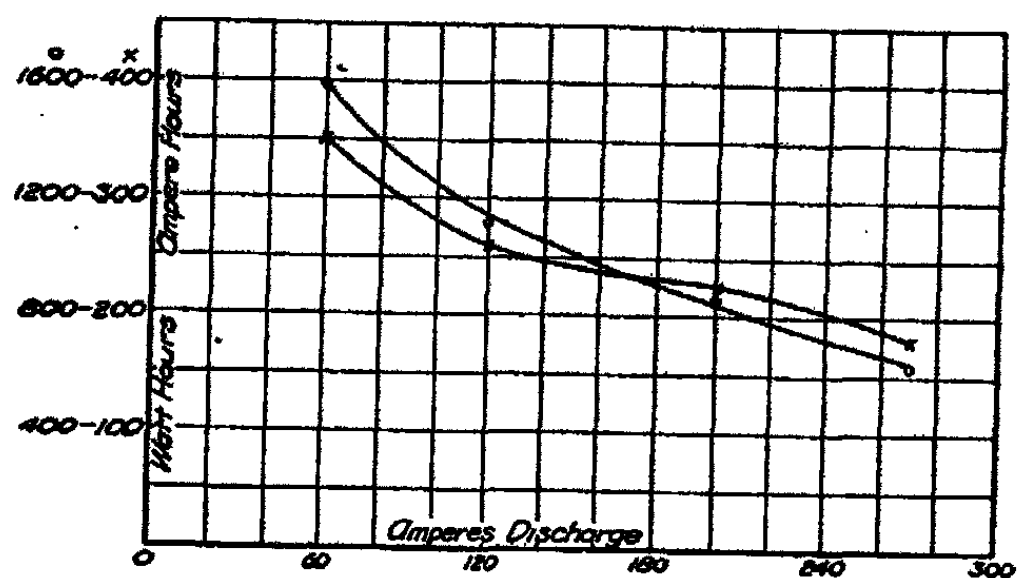

Fig. 3

that the battery is capable of operating at high rates with a remarkably small decrease in efficiency and capacity. An astonishingly small decrease in the average voltage is also noted at the higher rates of discharge.

It is stated that "booster" charges can be given these

cells practically. It was therefore decided to try some abnormal charging rates, discharging at the normal rate, calculating efficiency.

Below are given some of these tests.

TABLE 3

Charge	Watt-hours		Watt-hour efficiency Percent
	Input	Output	
2 hours at 120, balance at 60 amperes.....	3143	1463	46.5
1 hour at 200, balance at 60 amperes.....	2941	1536	52.2
1 hour at 300, balance at 60 amperes.....	3958	1543	39.0

With the "booster" charge of 200 amperes the charge was complete in about four hours and twenty-five minutes, the battery giving considerably over its rated output on discharge, the efficiency being about the same as for the normal charge.

The Edison cell is said to lose about 10 percent of its charge upon standing 24 hours, after which there is practically no loss. It was therefore decided to allow the charged battery to stand 30 hours and then measure the output upon discharge. It was found that the voltage of the battery had dropped to about 6 volts, and upon discharge the following was obtained:

TABLE 4

Discharge after standing 30 hours normal rate

Initial voltage	Average voltage	Output	
		Watt-hours	Ampere-hours
5.98	4.54	1384	305

The loss in capacity is about 10 percent of the normal output. In order to see if this loss could not be avoided in

cases where a battery is not to be used for some time after charging, it was decided to charge the battery to a definite voltage and discharge from this, taking the output. This arbitrarily selected voltage should be higher than the open circuit voltage of the battery after standing 30 hours. The drop across the battery on charge, upon momentarily closing the circuit, was found to be about 16 percent higher than the cell voltage upon open circuit. It was therefore decided to charge the battery until the drop across it was 16 percent higher than the voltage of the battery after standing 30 hours. The charge was therefore maintained until the voltage was 7.1 volts.

The following was obtained:

TABLE 5  
Battery charged to 7.1 volts and discharged at normal rate

Input		Output		Energy efficiency
Watt-hours	Ampere-hours	Watt-hours	Ampere-hours	
2101	315	1343	290	64

From this it may be seen that the output is practically the same as that for the discharge after standing 30 hours. The efficiency is very good under these conditions, and on the basis of a charge of this nature it seems as if the battery can approach favorable comparison with the lead cell in regard to efficiency. A measurement should have been made by charging up to this voltage, allowing to stand for 30 hours, to show that under these conditions there is practically no loss of the charge. On account of limited time, however, this could not be done.

In reference to the effect of low temperatures, it may be said that one charge and one discharge was obtained in an ice water bath, the temperature of the battery being kept at 4° C. The results of a charge at 4° C of the previously completely discharged battery at ordinary temperatures, and the

corresponding discharge are given. The efficiency cannot properly be calculated from these.

TABLE 6  
Charge and discharge at 4° C. Normal rate

Average voltage		Ampere-hour		Watt-hours		Duration Hours	
Charge	Dis-charge	Input	Output	Input	Output	Charge	Discharge
7.36	4.46	396	233	2920	1037	6-2/5	3-7/8

A very marked effect is obtained here. The voltage difference between charge and discharge is abnormally high.

The battery was later charged at the normal rate under ordinary conditions. This charge gives data for calculating efficiency comparable with that given above. This is the normal use of the cell in cold climates. In cars, of course, the battery would receive discharge at low temperatures on the road, and be charged at room temperature, in the garage. The results follow:

TABLE 7  
Charge after discharge at 4° C

Average voltage	Input		Efficiency calculated on previous discharge Percent
	Ampere-hours	Watt-hours	
6.94	460	3190	33

The fact that more energy was required for this charge than for the previous one probably means that nickel peroxide was not formed at 4° C, probably because the charge was not maintained long enough. If not accurately, the tests show, however, that there is a larger voltage difference between charge and discharge at low temperatures than under normal conditions. The efficiency must, therefore, be lower than normal.

From what has been said and from experience with the Edison cell it may be concluded, that

1. The energy efficiency, at the normal rate of operation, is about 55 percent, the ampere-hour efficiency being about 85 percent.
2. The cell is capable of operating continuously at high rates.
3. At the 40-minute discharge rate, with charge at the normal rate the energy efficiency is about 32 per cent, the ampere-hour output being about 60 percent of the rated output.
4. The cell can be charged at high rates, the efficiency being about normal when a "booster" charge at  $3\frac{1}{3}$  times the normal rate, for one hour, was given the cell. There is no reason why the cell should not be charged at 5 times the normal rate for a few minutes.
5. If the cell is to be charged the day before it is to be used, energy is conserved if the charge is maintained until the voltage reaches about 1.8 volts, instead of carrying it to completion. In other words, no nickel peroxide should be formed on charging, the loss of energy on standing being due, presumably, to the spontaneous decomposition of this compound.
6. If the charge is stopped before the higher oxidation products of nickel are formed, the efficiency is higher than normal, being about 64 percent.
7. At  $4^{\circ}\text{C}$  the battery is capable of delivering more than  $\frac{2}{3}$  its normal output, when charged at the same temperature. The voltage, of course, is lower than normal, for the internal resistance of the cell is higher at the lower temperatures. The efficiency also is low.
8. The cell may unquestionably be allowed to stand an indefinite length of time without injury.
9. The flexibility is so great that the cell can be used under the most adverse circumstances.
10. The method of charging until the voltage has remained constant for one hour gives satisfactory results, but requires watching or the use of a recording voltmeter.
11. The continuous drop in voltage on discharge (about

10 percent per hour) is a disadvantage against this cell, over the lead cell.

12. When referred to equal amounts of power, delivered, the Edison battery weighs about 25 percent less and costs about 25 percent more than the iron-clad Exide battery.

*Electrochemical Laboratory,  
Cornell University*

THE VALENCE OF OXYGEN, SULPHUR, NITROGEN  
AND PHOSPHORUS DETERMINED FROM THE  
MOLECULAR COHESION

BY ALBERT P. MATHEWS

1. *The valence of oxygen*

In my paper on the relation of molecular cohesion to molecular weight and valence,<sup>1</sup> in which the number of valences were computed from the value "a" of van der Waals' equation, I considered oxygen to be bivalent except in the case of oxygen gas. The question of the quadrivalence of oxygen was not taken up, because I wished to get the main point of the connection of valence and cohesion well established before discussing particulars. But as it is believed by many that oxygen is at times quadrivalent and as this possibility has such an important bearing on theories of association and solubility and, indeed, on the ionizing powers of water, and is also full of importance in physiology, it is interesting to examine the oxygen compounds of that table for evidence in favor of tetravalence.

One atom of oxygen is supposed by Stieglitz, Armstrong, and Goldschmidt<sup>2</sup> to be quadrivalent in the esters. In the first table, therefore, I have incorporated the results of a determination from the molecular cohesion by the usual formula:  $n = a^{3/2} \times 3.2 \times 10^5 / (\text{mol. wt.})$ , of the total number of valences per molecule, and compared it with the number of valences computed if one oxygen is quadrivalent. I have taken only those esters whose critical data were recently very carefully determined by Young. All of these esters associate a little at low temperatures, but their vapors are normal for some degrees below the critical temperature, except possibly that of methyl formate.

<sup>1</sup> Mathews: Jour. Phys. Chem., 17, 181 (1913).

<sup>2</sup> Zeit. Elektrochemie, 10, 221 (1904).

TABLE I

Substance	Formula	"a"	Theoretical No. of valences. One oxygen quadrivalent	Number of valences det. from cohesion.
Ethyl acetate	C <sub>4</sub> H <sub>8</sub> O <sub>2</sub>	0.04076	30	29.9
Ethyl formate	C <sub>3</sub> H <sub>6</sub> O <sub>2</sub>	0.03122	24	23.9
Ethyl propionate	C <sub>5</sub> H <sub>10</sub> O <sub>2</sub>	0.05088	36	36.0
Methyl acetate	C <sub>3</sub> H <sub>6</sub> O <sub>2</sub>	0.03206	24	24.8
Methyl butyrate	C <sub>5</sub> H <sub>10</sub> O <sub>2</sub>	0.05082	36	35.9
Methyl formate	C <sub>2</sub> H <sub>4</sub> O <sub>2</sub>	0.02371	18	19.5
Methyl isobutyrate	C <sub>5</sub> H <sub>10</sub> O <sub>2</sub>	0.04882	36	33.8
Methyl propionate	C <sub>4</sub> H <sub>8</sub> O <sub>2</sub>	0.03968	30	28.8
Propyl acetate	C <sub>5</sub> H <sub>10</sub> O <sub>2</sub>	0.05149	36	36.7
Propyl formate	C <sub>4</sub> H <sub>8</sub> O <sub>2</sub>	0.04086	30	29.7

From Table I it is clear that the number of valences computed from the molecular cohesion is very close to the theoretical number, if one of the oxygen atoms is quadrivalent. The only cases in which fewer valences were found were methyl isobutyrate and methyl propionate. In the former, the computation of "a" may not be exactly right as elsewhere pointed out, the isocompounds always giving a value for "a" a little low as compared with the normal. It is, of course, possible that in them the oxygen is bivalent.

Table 2 contains some other oxygen compounds which associate and may be supposed on that account to have quadrivalent oxygen.

In Table 2 the alcohols probably associate somewhat at the critical temperature and acetic acid also; the number of valences, given in the table as computed, were computed with the normal molecular weight and they are, accordingly, too many. It is impossible to determine the total number of valences per molecule by this method for these substances until the average molecular weight has been independently determined at the critical temperature. Of the other substances: acetone, anisol, phenetol, nitrobenzene, acetic anhydride, ethyl diacetate and methyl propyl ketone appear to have tetravalent oxygen. The method, however, is not



TABLE 2

Substance	Formula	"a"	Number of valences computed; one oxygen quadrivalent	No. of valences found
Acetone	$C_3H_6O$	0.02459	22	21.3
Ethyl alcohol	$C_2H_6O$	0.02395	18	25.8 (Assoc.)
Anisol	$C_7H_8O$	0.05645	40	39.8
Methyl alcohol	$CH_4O$	0.01895	12	26.0 (Assoc.)
Phenetol	$C_8H_{10}O$	0.07009	46	48.7
Propyl alcohol	$C_3H_8O$	0.03250	24	31.3 (Assoc.)
Acetic acid	$C_2H_4O_2$	0.03504	18	34.9 (Assoc.)
Nitrobenzene	$C_6H_5NO_2$	0.05968	38	37.9
Acetic anhydride	$C_4H_6O_3$	0.04442	30	29.3
Ethyl diacetate	$C_8H_{10}O_3$	0.06668	42	42.4
Methyl propyl ketone	$C_5H_{10}O$	0.04437	34	34.8
<i>m</i> -Cresol	$C_7H_8O$	0.06254	40	46.0 (Assoc.)

sufficiently accurate to enable this conclusion to be drawn without reservation. The critical data of some of these substances have not been determined with entire accuracy and it is possible, in some, that a very small amount of association may occur at the critical temperature and such association would have the effect of making uncertain the valence determination. With these reservations, however, this method undoubtedly supports the view that oxygen may be tetravalent, and particularly that one atom is tetravalent in the esters.

The method shows oxygen to be bivalent in ether, sulfur dioxide, carbon dioxide and one of the oxygen atoms of the esters.

In oxygen gas, carbon monoxide and nitric oxide, NO, the oxygen is monovalent, if computed from the cohesion. The maximum number of valences in a molecule of oxygen found by this method was two. It must be confessed that it seems unlikely that oxygen is monovalent in the gaseous form, but the critical data are accurately determined and if this method of determining valence is reliable, as it appears to be, there is no escaping the conclusion. The critical data of carbon monoxide should be redetermined, but from those

accepted only two valences can be found in the molecule. Nitric oxide has always been a puzzle, since the oxygen is monovalent, or the nitrogen bivalent. The cohesion shows that there are only two valences, which again means that the oxygen and nitrogen are monovalent.<sup>1</sup>

From its cohesion, then, oxygen appears to be either monovalent, bivalent, or tetravalent.

### 2. Sulfur

Sulfur is generally supposed to be bivalent, but at times to open up two or four residual valences. So far I have not found any compounds with bivalent sulfur, except probably carbonyl sulfide, when the valence is computed from the cohesion. All the sulfur compounds have either quadrivalent or hexavalent sulfur, if the valence is determined by this method. Even sulfuretted hydrogen is no exception to this statement. Table 3 contains the results.

TABLE 3—THE VALENCE OF SUBSTANCES CONTAINING SULFUR

Substance	Formula	"a"	Valences per mol.		Valences per mol. by cohesion
			S = 6	S = 4	
Hydrogen sulfide	H <sub>2</sub> S	0.00890	8	6	7.9
Mercaptane	C <sub>2</sub> H <sub>6</sub> S	0.02497	20	18	20.4
Thiophenè	C <sub>4</sub> H <sub>4</sub> S	0.04130	26	24	32.0 (Assoc.)
Sulfur dioxide	SO <sub>2</sub>	0.01349	10	8	7.8
Carbon bisulfide	CS <sub>2</sub>	0.02316	16	12	14.8
Sulfuryl chloride	SO <sub>2</sub> Cl <sub>2</sub>	0.04382	16	14	14.1
Thionyl chloride	SOCl <sub>2</sub>	0.03110	14	12	14.8

<sup>1</sup> A very interesting fact which may be cited in support of the view that oxygen in these three gases is in a state different from the ordinary, and, hence, possibly monovalent, is the following: Oxygen gas and nitric oxide are strongly paramagnetic, and carbon monoxide is far more paramagnetic, or rather far less diamagnetic, than carbon dioxide which contains more oxygen. In all other compounds oxygen is diamagnetic. It is clear that the oxygen in the three gases which this method shows to contain monovalent oxygen has magnetic properties different from oxygen in other oxygen compounds. This fact has not hitherto been explicable. The following figures showing the para- or diamagnetism of different gases I have taken from Auerbach's article on Magnetism in the Handbuch der Physik, 5, 274 (1908).

O<sub>2</sub> NO CO Air C<sub>2</sub>H<sub>4</sub> CH<sub>4</sub> CO<sub>2</sub> N<sub>2</sub>O N<sub>2</sub> H<sub>2</sub>  
 +4.83; +1.60; -0.009; 1; -0.068; -0.063; -0.033; -0.018; -0.015; -0.002(?)

From Table 2 it appears that sulfur is quadrivalent in sulfur dioxide and sulfuryl chloride; hexavalent in sulfuretted hydrogen, carbon bisulphide, mercaptane, thionyl chloride and probably in thiophene. It is probably bivalent in carbonyl sulphide, but the critical data are uncertain. These results are in agreement with the general idea of the valence of sulfur except in the case of sulfuretted hydrogen, mercaptane, and carbon bisulfide. Thiophene probably associates a little at the critical temperature so that the valence computation is uncertain.

### 3. Nitrogen

Nitrogen is generally supposed to be either mono-, tri- or pentavalent. The cohesion method supports this conclusion. Nitric oxide has been a stumbling block. The results are given in Table 4.

TABLE 4—NUMBER OF VALENCES PER MOLECULE OF NITROGEN COMPOUNDS

Substance	Formula	"a"	Number of valences found from cohesion	Number computed		
				N = 1	N = 3	N = 5
Nitrogen	N <sub>2</sub>	0.0032808	2.0	2	6	10
Nitrous oxide	N <sub>2</sub> O	0.009465	6.2	4	8	
Nitric oxide	NO	0.002570	1.4	2	4	
Nitric dioxide	NO <sub>2</sub>	0.01119	7.6		7	9
Ammonia	NH <sub>3</sub>	0.00844	13.5		6	8 (Assoc.)
Methyl amine	CH <sub>3</sub> N	0.01521	17.9		12	14 (Assoc.)
Dimethyl amine	C <sub>2</sub> H <sub>7</sub> N	0.01922	17.5		18	20
Trimethyl amine	C <sub>3</sub> H <sub>9</sub> N	0.02594	22.7		24	26
Diethyl amine	C <sub>4</sub> H <sub>11</sub> N	0.03625	27.9		30	
Triethyl amine	C <sub>6</sub> H <sub>15</sub> N	0.05415	39.9		42	
Propyl amine	C <sub>3</sub> H <sub>9</sub> N	0.02729	24.5		24	
Dipropyl amine	C <sub>6</sub> H <sub>15</sub> N	0.05835	51.2		52	
Aniline	C <sub>6</sub> H <sub>7</sub> N	0.05157	37.2		34	36
Dimethyl- <i>o</i> -toluidine	C <sub>9</sub> H <sub>13</sub> N	0.08187	51.2		52	54

From the table it appears that nitrogen in nitrogen gas is monovalent. It appears to be also monovalent in nitrous and nitric oxide. Two formulas may be written for nitrous oxide with a total valence of six, *i. e.*, N— $\overset{\vee}{\text{O}}$ —N or N—N=O.

I think the former, with some of the molecule having quadrivalent oxygen, is perhaps the more probable. I have taken the highest possible value of "a" for nitrous oxide. In nitric oxide two valences per molecule are the most that can be assigned by this method. This would mean that both elements were monovalent, but as there is other evidence that oxygen is univalent in its elemental form, this formula is not entirely improbable. The valence of nitrogen in nitric dioxide is quite uncertain. In the amines there can be hardly a doubt that it is trivalent, or at times pentavalent with two free valences on the nitrogen. This is the case in ammonia and methyl amine, both of which associate. All of the critical data of the amines were determined by Vincent and Chappuis and I believe their figures are uniformly a little too low. In aniline the nitrogen appears to be pentavalent, but some association occurs. The results are not, then, very satisfactory for these compounds, but they indicate very clearly, however, that nitrogen is either monovalent, trivalent, or pentavalent, as it is supposed to be.

#### 4. Phosphorus

I have found but a single phosphorus compound in which the critical data have been directly determined, although one or two other cases were reported in my paper on the valence of chlorine, in which the critical data had been computed from the surface tension.

In phosphoretted hydrogen the phosphorus is apparently pentavalent, having two free valences. "a" is given by Leduc and Sacerdote as 0.00939 and from this the valence of 8.6 is computed. Were the phosphorus pentavalent the total number of valences would be eight. It might be, however, that the phosphorus was heptavalent, but only a few of the molecules had the two pairs of reserve valences open at the same instant. In the chlorine compounds it appeared that the phosphorus was probably heptavalent. I think the only certain conclusion is that the valence is greater than three.

*University of Chicago*

## THE VALENCE OF THE ARGON GROUP AS DETERMINED FROM THE MOLECULAR COHESION

BY ALBERT P. MATHEWS

The valence of the argon group of elements is one of the most interesting problems in chemistry. They are very generally regarded as zero valent, chiefly owing to the position they take in the periodic system between strongly electro-positive and electro-negative, univalent elements. That they are monatomic is undoubted, but they might be monatomic, like mercury vapor, and still have valence. Ramsay<sup>1</sup> made the suggestion, indeed, that they combine into molecules at other than ordinary temperatures. To account for the atomic weight of argon, which computed from the density is 39.9 if the gas is monatomic, he suggested that argon is a mixture of many monatomic molecules with a few diatomic molecules. The ratios of the specific heats as determined is 1.659; whereas if there were 5 percent of diatomic molecules it would be 1.648. The theoretical number, if the gas is entirely monatomic, is 1.667. After discussing this possibility, however, Ramsay says: "But on the whole the presumption is against the hypothesis that argon is a mixture of monatomic and diatomic molecules."

There is some evidence that argon is not entirely lacking in chemical affinity. Berthelot,<sup>2</sup> by the action of the electric discharge on a mixture of argon and benzene vapor, or of argon and carbon bisulphide, produced a brownish deposit on the glass from which argon could be reobtained. Ramsay,<sup>3</sup> in commenting on the absence of the argon lines in the sun's spectrum, suggests, as a reason, that it enters into combination only at high temperatures, these compounds being endothermic; and he cites<sup>4</sup> several observations indicating

<sup>1</sup> Ramsay: "Gases of the Atmosphere," London, p. 231 (1902).

<sup>2</sup> Berthelot: *Comptes rendus*, 120, 581, 660, 1316 (1895); 124, 113 (1897).

<sup>3</sup> Ramsay: *Loc. cit.*, p. 261.

<sup>4</sup> Ramsay: See footnote, p. 538, to article by C. Trenton Cooke: *Zeit. phys. Chem.*, 55, 537 (1906).

a union of argon with zinc, mercury and some other elements. Thus in a Plücker tube the cathode metal disintegrates more rapidly when argon under low pressure is in the tube than when nitrogen is there, and Ramsay interprets this to mean that a volatile compound is formed under the influence of the intense energy at the surface of the electrode and this compound dissociates again setting free the metal, which deposits on the glass. Under his direction C. Trenton Cooke<sup>1</sup> measured the vapor tension of zinc, cadmium, sulfur, mercury and some other metals at high temperatures in the presence of various gases and concluded that the tension of zinc in argon was 12 percent above its tension in nitrogen. Cadmium behaved similarly in helium. Helium seems to be in some kind of a union in fergusonite, and to be capable of feebly uniting with platinum. It may be recalled, also, that the solubility of argon in water is greater than that of helium and nitrogen; and this may be urged as indicating some kind of affinity between water and argon. Chemically, then, these gases, though inert, are not entirely indifferent.

From their action on light,<sup>2</sup> also, a certain argument may be made for their possessing valence. Thus, according to Drude, the dispersion of light in the blue end of the spectrum is due to the valence electrons, and in the red end to the vibrations of the electrically charged atomic groups. If only the valence electrons affect blue light, these gases must also have valence electrons, since they refract light like other gases.

The question whether these elements have valence, or not can be put to a decisive test through their molecular cohesions.<sup>3</sup> There is no question that they possess cohesion, since they can all be liquefied. They behave like all other gases in this respect. Molecular cohesion in all other substances examined is a function of the product of the molecular weight by the number of valences. It has been shown for a

<sup>1</sup> C. Trenton Cooke: *Loc. cit.*, p. 537.

<sup>2</sup> Cuthbertson, C.: "Refractive Indices of the Elements," *Phil. Trans.*, 204, 323 (1904).

<sup>3</sup> Mathews: *Jour. Phys. Chem.*, 17, 181 (1913).

great number of substances that  $M^2K$ , a factor proportional to "a" of van der Waals' equation, is equal, when expressed in dynes, to  $2.98 \times 10^{-37}$  (mol. wt.  $\times$  No. of valences) $^{3/2}$ . A substance having cohesion cannot, therefore, have zero valence. If it had no valence it could have only gravitational attraction between its monatomic molecules, no cohesive attraction. These gases have cohesion and they must, therefore, have valence.

Their valence,  $n$ , can be calculated from their critical data by the formula: (1)  $n = 0.0043 T_c^3/P_c^{3/2}$  (mol. wt.); or,  $n = a^{3/2} \times 3.2 \times 10^6/(\text{mol. wt.})$ ; or (2)  $n = 4.21 \times 10^{-6} (V_c T_c)^{3/2}/(\text{mol. wt.})$ . The first formula, which is derived from the ordinary formula for computing "a" from the critical temperature and pressure, gives values for "a," and hence for  $n$ , a little lower than the second formula in the case of simple gases. The second formula computes "a" from the surface tension, as shown in my former paper. In Table 1, I have given both values and I regard the second as the more correct; but as the critical density of not all the gases is known, I have had to rely on the first formula for a comparison. The results given by the two formulas are not widely different.

The valence,  $n$ , together with the critical data<sup>1</sup> used in the calculation are given in Table 1.

TABLE 1.—COMPUTATION OF THE AVERAGE NUMBER OF VALENCES PER MOLECULE FROM THE MOLECULAR COHESION

Substances	$T_c$ (Abs.)	$P_c$	$d_c$	Number of valences by formula 1	Number of valences by formula 2
Helium	5.5°	2.75	0.065	0.04	0.07
Helium	8.0	2.75	0.065	0.12	0.12
Neon	61.1	29	—	0.32	—
Argon	150.56	48	0.509	1.12	1.35
Krypton	210.53	54.3	—	1.23	—
Xenon	289.6	58.2	1.155	1.80	1.95

<sup>1</sup> In my preliminary paper, *Science*, N. S., 36, 6 (1912), in Table I a mistake occurred in the computation of helium. The value 2.90 is wrong. The critical density was taken as 0.015 instead of 0.065.

Before discussing these results a word may be said about the reliability of the critical data. Those of argon and xenon are perhaps the most certain; krypton, neon and helium follow in the order named, helium being least certain. Onnes<sup>1</sup> gives  $5.5^{\circ}$  absolute as the critical temperature of helium, but as this makes helium quite aberrant in several particulars,<sup>2</sup> I have also computed the valence assuming the critical temperature to be  $8^{\circ}$  as suggested by Dewar.<sup>3</sup> The critical data of neon are somewhat uncertain, due in part to the very low critical temperature and in part to the great difficulty in separating the gas completely from helium. A little impurity of the latter gas would have the effect of making  $P_c$  too high.

It is clear from the table that all of these gases possess valence. They are not zero valent as they are supposed by many to be. Furthermore, the average number of valences per molecule is in no case an exact integer, although in argon and xenon it is not far from a whole number. Since these gases have their critical data most accurately determined I at first supposed, as I published in my preliminary paper, that argon was univalent, but slightly associated into diatomic molecules, thus bringing the average number of valences per molecule a little high; and that xenon was divalent. I attributed the deviation of the other gases from univalency, to the inaccuracy of the data. A careful examination of all the facts, however, has led me to abandon this explanation for what seems to me to be a better one, since it explains all the facts.

In the first place, I have not been willing to abandon the idea that valences are indivisible. If we assume, as Lodge<sup>4</sup> suggests, that some of the lines of force from each valence attach themselves to several atoms, or even wander outside

<sup>1</sup> Onnes: Proc. Amsterdam Acad. Sci., 13, 1100 (1911).

<sup>2</sup> Rankin: "On a Relation between Viscosity and Atomic Weight of Inert Gases," Phil. Mag., [6] 21, 45 (1911).

<sup>3</sup> Dewar: Article "Liquid Gases," Encyclopaedia Britannica, 16, 749, 11th ed.

<sup>4</sup> Lodge: Nature, 70, 176 (1904).



the molecule, and thus split the valence up; or that there are partial valences in the sense of Kauffmann,<sup>1</sup> it seems to me that we might as well abandon the whole valence idea. It entirely loses its usefulness. Again our structural formulas become so indefinite, if the valences are regarded as split up, as to be nearly useless. The explanation which I sought was one which would explain why we appear to have fractional valences in this case, but really do not have them. That my first explanation was wrong, was indicated by the uniformity with which the valence increases from helium to xenon. The deviation, too, from univalency in the case of neon is so great that it lies outside the limits of error. The critical pressure would need to be 14 atmospheres instead of that recorded of 29 atmospheres, in order that neon should have one valence to each molecule. The uncertainty of the critical pressure is far less than this.

I believe the reason that the average number of valences is a fraction in these gases is as follows: All of them are in reality zero valent, so far as their *chief* valences are concerned, but like many, if not all, other elements, they have the power of opening up two residual valences. By their residual valences, therefore, they are all bivalent. These two valences, like most, or all, other residual valences, are of opposite electrical sign, one being positive, the other negative. Not all the atoms have these residual valences open at the same instant, but always some of the atoms have them closed. The molecular cohesion, as I have already pointed out, is not influenced by these valences when they are in a closed or reserve state, or, we might say, withdrawn within the atom; it is only affected by the valences actually extending between atoms, or open and in a state in which they may combine. In xenon nearly all the atoms, or at any rate, 90 percent of them, have the valences open, and the average valence per atom, or molecule, is, therefore, 1.80-1.95; in krypton about 65 percent of the atom have open valences, and 35 percent are closed, so that the average valence is about 1.30; in argon,

<sup>1</sup> Kauffmann: Ber. chem. Ges. Berlin, 41, 4404 (1908).

about 60 percent are open and 40 percent are closed, the average valence being about 1.20; in neon, 16 percent are open and 84 percent are closed, the average valence being about 0.32; and in helium only about 5 percent of the valences are open, 95 percent being closed, giving an average valence of 0.10. This explains, then, why the elements appear zero valent in the periodic table, since they are zero valent as far as their chief valences are concerned; why, nevertheless, they appear to have some weak chemical affinity, and cohesion; why they refract and disperse light; and also why the average valence is fractional rather than being a whole number.

It also explains more than this. It enables us to understand the easy dissociation of the molecules into atoms. Unlike atoms that are bound together into molecules by their chief valences, no electrical stresses are set up in the argon elements when dissociation into atoms occurs, because each atom having a positive and a negative valence becomes at once electrically neutral. It is well known that compounds formed from residual valences partake of the nature of molecular compounds and break up very easily. Neither their union, nor their dissociation, involves much, if any, energy exchange. Such compounds are often called, indeed, molecular compounds. A double bond of this kind is always a weak bond in any molecule, which easily breaks where the double bond is. Were they univalent their dissociation into atoms would be very hard to understand.

I suppose we may picture the opening of these residual valences in the manner suggested by Sir J. J. Thomson, as being due to a rearrangement of the electrons within the atom so that an excess of negative electricity is temporarily produced in one spot, and of positive at another spot on the surface of the atom. These excesses are the valences.

In closing, it is not without interest to compare the valence numbers computed above from the cohesion, with the refractivity as determined by Cuthbertson.<sup>1</sup> Their refractivities are in the proportion 1, 2, 8, 12 and 19.

<sup>1</sup> Cuthbertson, C.: *Phil. Trans.*, 204, 323 (1905).

	Refractivity $(\mu - 1)10^6$	Ratio	Valence	Ratio
Helium	36.3	1	0.1	1
Neon	68.7	1.9	0.32	3.2
Argon	284	7.82	1.12	11.2
Krypton	425	11.7	1.23(?)	12.3
Xenon	689	18.98	1.80	18.0

There is a general similarity, but not an identity.

The principal facts and conclusions of the paper are: The molecular cohesion, confirming other properties, shows that the argon group of elements have valence. A computation of the average number of valences per molecule from the molecular cohesion gave the following results: He, 0.1; Ne, 0.32; Ar, 1.12; Kr, 1.23; Xe, 1.80. The valences are apparently fractional, and not whole numbers. The conclusion is that these elements are all zero valent, as far as their chief valences go, but each is divalent in its residual valences. At any one instant of time only a certain proportion of the atoms, varying in the different gases, have their residual valences open, consequently the average number of valences actually open, or active, per molecule is less than two. One residual valence is positive, the other negative; and hence the combining power of the atoms is very weak, since on dissociation an electrically neutral atom is formed, by the saturation within the atom of the oppositely charged valences. This explanation enables us to understand, also, why there is a progressive increase in solubility of these gases in water from helium to xenon if solution be a process involving the union of solvent and solute through their residual valences.

*University of Chicago*

## NEW ELECTRIC PROPERTIES OF A SEMIPERMEABLE MEMBRANE OF COPPER FERROCYANIDE

BY REINHARD BEUTNER

1. The well-known investigations of Nernst have shown that potential differences which compose the electromotive force of whole cells are located at the junction of metal and solution and depend on the concentration of the solution according to a logarithmic law.

A concentration cell is, e. g.,

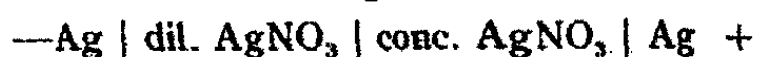

which may also be arranged with one single piece of Ag as a middle conductor (and calomel electrodes in order to make an electrical connection to the measuring instrument) as follows:

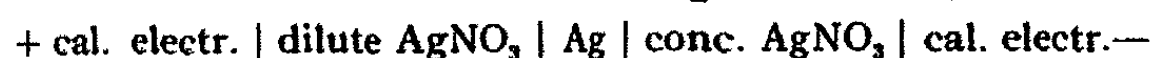

In an investigation,<sup>1</sup> based upon a thermodynamic theory of Nernst, Haber found that the middle-conducting Ag-metal in the last cell can be replaced by a solid middle-conducting layer of AgCl without causing the slightest change in the electromotive force of the cell. Through further experimental investigations, it has been proved beyond doubt that the solid AgCl possesses an electrolytic conductivity.<sup>2</sup> As to the electromotive properties, however, it resembles the metals; from a thermodynamic standpoint this peculiar property can be explained by the fact that equilibrium exists at the junction with the immiscible AgCl. A theory based upon this fact has been devised in different forms by Nernst and Haber; an account of a similar theory (based upon the same principles) was also published by the writer in an American paper.<sup>3</sup>

<sup>1</sup> Drude's Ann., 26, 947 (1908); cf. also Nernst: Zeit. phys. Chem., 9, 140 (1892).

<sup>2</sup> This can be proved by the polarization which occurs if a current is sent through AgCl. LeBlanc's hypothesis of temporary electronic conduction in AgCl is based upon a misconception as admitted by himself (Zeit. Elektrochem., 16, 240, 680 (1910); see Haber: Loc. cit.). Drude's Ann., 26, 972 (1908).

<sup>3</sup> Trans. Am. Electrochem. Soc., 21, 219 (1912).

2. In some experimental work along biological lines by Dr. Jacques Loeb and the writer<sup>1</sup> it was found that certain vegetable and animal skins exhibited a change of potential difference with changing concentration similar to that with metals, *i. e.*, a combination:

cal. electr. | M/10 KCl | skin of a fruit or leaf | M/1250 KCl | cal. electr.  
(as middle conductor)

shows an electromotive force of about 0.09 volt. Since the calomel electrodes used were filled with M/10 KCl, no liquid potential differences can occur in the whole combination (owing to the well-known fact that the migration velocities of K<sup>+</sup> and Cl<sup>-</sup> are equal). The electromotive force observed must therefore be located at the junctions of the aqueous solutions and skin. If we assume that the skin behaves like an electrode reversible for K<sup>+</sup> ions and try to apply the well-known logarithmic formula of Nernst

$$E = \frac{RT}{nF} \ln \frac{C_1}{C_2}$$

(or at room temperature and for  $n = 1$ )

$$= 0.058 \log \frac{C_1}{C_2} = 0.12 \text{ volt}$$

we find indeed an electromotive force which about equals the electromotive force observed, at least in order of magnitude.

The sign of this electromotive force is such as one would expect with a reversibility for cations. The most characteristic property of such cells, however, is that there is not a *reversibility for K<sup>+</sup> cations alone but for any other cation as well*, for if we replace the two KCl solutions in the above combination by two NaCl solutions of equal respective molecular concentrations, we find a similar electromotive force.

It must be said that in this case the liquid potential differences are no longer zero, yet their difference will not account for more than 10 percent of the observed electromotive force. A solution containing the salt of any alkali

<sup>1</sup> *Biochem. Zeit.*, 41, 1 (1912).

or alkaline earth shows a similar change of potential difference with changing concentration. Acids, caustic alkalis, and salts of the heavy metals give rise also to a small electromotive force in similar "concentration cells," but the latter have not yet been studied in detail because, in such cases, the skin is likely to be attacked chemically by the salt of the heavy metals (poisonous effect) and the phenomena are of a more complex character.

3. In this communication, I wish to show the circumstances under which the electromotive properties characteristic of the skin (or outside membrane) of tissues may be imitated by an artificial semipermeable membrane of copper ferrocyanide. It is well known through the famous investigations of Traube that this artificial membrane gives rise to osmotic phenomena similar to those produced by the animal or plant membranes. Though the tissue membranes certainly possess a chemical composition which is most materially different from that of the artificial membrane, the similarity of osmotic phenomena with both membranes points to the fact that they have some identical physical properties. It is remarkable that there exists a certain similarity of electric phenomena also, as the following experiments prove.

The measurements of electromotive force with precipitation membranes were performed in the following way: A glass tube, about 2 cm wide and open at both ends, was filled with a warm solution of M/40  $K_4Fe(CN)_6$  and 10 percent gelatine. This solution was allowed to cool down in the tube to room temperature and to become stiff. The tube was then immersed with one end in a beaker containing M/20  $CuSO_4$  (Fig. 1). A precipitation membrane formed instantly upon the gelatine and soon grew to considerable thickness, although hardly visible at first.

The points of two calomel electrodes were then immersed, the one into the M/20  $CuSO_4$  solution in the beaker, the other into a small quantity of M/10 KCl which was poured upon the opposite (upper) end of the gelatine layer (see diagram). Electrical connections were made to a "binanten-electrom-

eter" (of Dolezalek); the electromotive force measured was 0.115 volt and the  $\text{CuSO}_4$  solution was at the positive side; the electromotive force remained constant for 10 minutes.

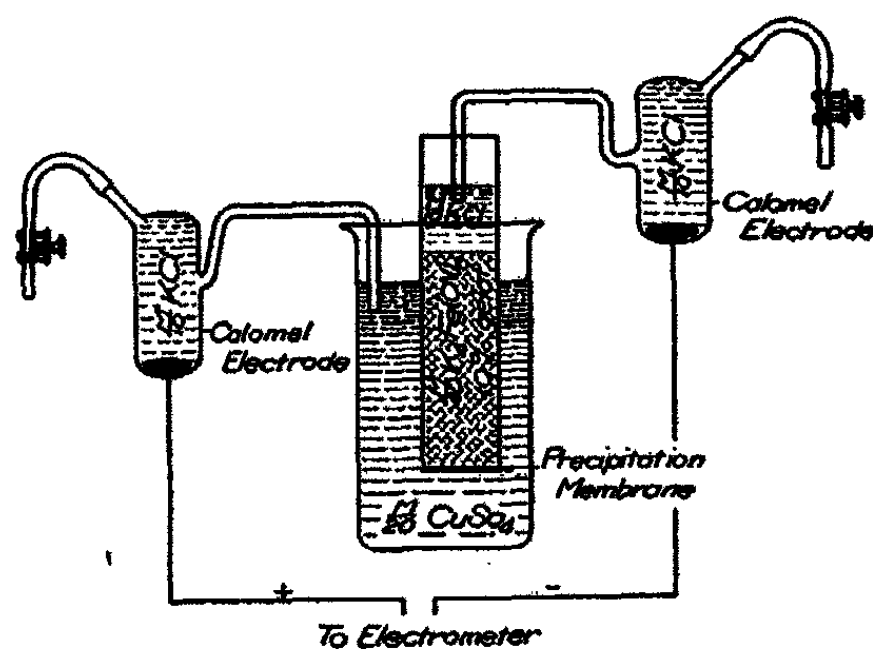

Fig. 1

Another experiment of the same kind gave the electromotive force of 0.108 volt (constant); the experiment was further repeated several times with similar results, the electromotive force varying from 0.103 to 0.120 volt.<sup>1</sup>

4. I wish to point out first that this electromotive force can hardly be located at any other place than on either side of the membrane. It is well known that the liquid potentials, which exist at the junction of aqueous solutions, depend on ionic mobility; their order of magnitude is up to 0.06 volt in case the solution concerned contain either  $\text{H}^+$  or  $\text{OH}^-$  or both, on account of the great ionic mobility of these two ions. As no free acid or alkali is contained in our solutions, the liquid potentials will hardly exceed 0.01 volt, *i. e.*, 10 percent of the electromotive force observed.

<sup>1</sup> In order to measure electromotive force produced by the membrane, it is essential not to precipitate it into a porous cup as is usually done for osmotic measurements. It is known from experiments of Brünings (Pflüger's Archiv., 117, 425 (1907)) that clay may also give rise to an electromotive force, which might interfere with the electromotive force of the membrane itself.

I have previously referred to Haber's research on the cell  
 — cal. electr. | cont. AgNO<sub>3</sub> | AgCl | dilute AgNO<sub>3</sub> | cal. electr. +  
   middle  
   conductor

in which the AgCl acts like Ag metal (as to the electromotive force).

The question presents itself whether the insoluble Cu<sub>2</sub>Fe(CN)<sub>6</sub> in our "cell"

+ cal. electr. | CuSO<sub>4</sub> | Cu<sub>2</sub>Fe(CN)<sub>6</sub> | K<sub>4</sub>Fe(CN)<sub>6</sub> | cal. electr.—  
   middle                  solution  
   conductor

acts like Cu. Apparently this is *not* the case, as is easily understood by the fact that the electromotive force of the Cu<sub>2</sub>Fe(CN)<sub>6</sub> "cell" has the opposite sign from that of the AgCl "cell." The CuSO<sub>4</sub> solution should be at the negative pole if the analogy of the two "cells" was right. Apparently the precipitation membrane possesses very different qualities from a solid insoluble salt (like AgCl).

How is the electromotive force observed really to be explained? I have found an answer to this question by means of experiments in which the M/20 CuSO<sub>4</sub> solution in the beaker was replaced by solutions of various composition and the influence upon the electromotive force observed.

5. The M/20 CuSO<sub>4</sub> solution was replaced,<sup>1</sup> first by more dilute CuSO<sub>4</sub> solutions. An irregular change of the electromotive force was observed in this case, most likely on account of the fact that the membrane underwent mechanical changes through osmosis. With a more dilute CuSO<sub>4</sub> solution in the beaker, strips of the membrane grew downward apparently on account of the greater osmotic pressure of the K<sub>4</sub>Fe(CN)<sub>6</sub> solution upon the other side. This osmosis necessarily affects the composition of the solutions on both sides of the membranes in a way which cannot be determined or controlled experimentally.

In order to eliminate the disturbing osmotic processes

<sup>1</sup> In replacing the solutions in the beaker care was taken not to injure the membrane.



further experiments were performed in such a way that the M/20 CuSO<sub>4</sub> solution was diluted *not with water but with a M/10 grape-sugar solution*, thus the osmotic pressure of the solution in the beaker was kept pretty nearly constant.<sup>1</sup>

The effect of the concentration of CuSO<sub>4</sub> on the electromotive force was found to be such that the electromotive force decreased with decreasing concentration; the change however was very irregular and varied with the time. It can hardly be considered as an effect of concentration of the same kind as at a reversible electrode; it is more likely that irregular changes occur in the chemical composition of the membrane because one of the substances that generates the membrane is partially taken away; perhaps also a mechanical destruction of the membrane takes place.

The following observations may illustrate this irregular change of the electromotive force:

Time in minutes	Comp. of sol. in the beaker	E. m. f.
0	M/20 CuSO <sub>4</sub>	0.115 volt
10	M/20 CuSO <sub>4</sub>	0.115 volt
14	M/10 grape-sugar (no CuSO <sub>4</sub> )	0.077 volt
17	M/10 grape-sugar (no CuSO <sub>4</sub> )	0.070 volt
18	M/12500 CuSO <sub>4</sub> [diluted from	0.062 volt
22	M/20 CuSO <sub>4</sub> with M/10 sugar]	0.064 volt
23	M/2500 CuSO <sub>4</sub> (dil. with M/10 sugar)	0.057 volt
26	M/500 CuSO <sub>4</sub> (dil. with M/10 sugar)	0.045 volt
33	M/100 CuSO <sub>4</sub> (dil. with M/10 sugar)	0.044 volt
33	M/100 CuSO <sub>4</sub> (dil. with M/10 sugar)	0.054 volt
38	M/100 CuSO <sub>4</sub> (dil. with M/10 sugar)	0.070 volt
46	M/100 CuSO <sub>4</sub> (dil. with M/10 sugar)	0.092 volt
54	M/100 CuSO <sub>4</sub> (dil. with M/10 sugar)	0.102 volt
56	M/20 CuSO <sub>4</sub> (dil. with M/10 sugar)	0.101 volt
58	M/100 CuSO <sub>4</sub> (dil. with M/10 sugar)	0.114 volt
61	M/100 CuSO <sub>4</sub> (dil. with M/10 sugar)	0.115 volt
63	M/20 CuSO <sub>4</sub> (dil. with M/10 sugar)	0.110 volt

<sup>1</sup> It is well known that a M/20 CuSO<sub>4</sub> sol. and a M/20 sugar sol. are *not* perfectly isotonic, and also the M/40 K<sub>4</sub>Fe(CN)<sub>6</sub> sol. on the opposite side of the membrane is not exactly isotonic. It was observed, however, that the differences in question did not interfere materially with the electromotive force. Irregular electromotive forces were observed only if the osmotic pressure was changed in a considerable ratio, *i. e.*, 1 : 2 or 1 : 5.

Further experiments gave similarly irregular data.

6. Apparently it is essential to have a constant osmotic pressure *and* also a constant quantity of  $\text{CuSO}_4$  in the solution in order to keep up a membrane of constant composition and properties. It was found that if these conditions were observed *the electromotive force underwent regular and reversible changes if an alkali salt was added to the solution in the beaker.* The direction of the change was such that with increasing concentration of the alkali salt the electromotive force became smaller, *i. e.*, the solution in the beaker more negative; the effect is therefore of the same kind as with the potential differences:

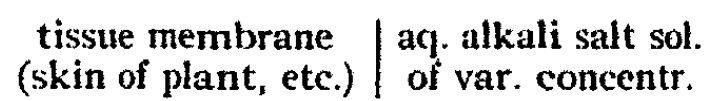

investigated by J. Loeb and the writer (see above).

The following experiments may serve as examples:

Time in minutes	Comp. of sol. in the beaker	E. m. f.	Difference of e. m. f.
0	M/40 $\text{CuSO}_4$ + M/20 sugar	0.122 volt	
17	(no alkali salt)	0.123 volt	
26	M/40 $\text{CuSO}_4$ + M/40 KCl	0.020 volt	
35	M/40 $\text{CuSO}_4$ + M/40 KCl	0.019 volt	} 0.041 volt
39	M/40 $\text{CuSO}_4$ + M/200 KCl <sup>1</sup>	0.062 volt	
43	M/40 $\text{CuSO}_4$ + M/200 KCl	0.060 volt	} 0.039 volt
46	M/40 $\text{CuSO}_4$ + M/1000 KCl	0.099 volt	
54	M/40 $\text{CuSO}_4$ + M/1000 KCl	0.097 volt	} 0.035 volt
55	M/40 $\text{CuSO}_4$ + M/200 KCl	0.062 volt	
58	M/40 $\text{CuSO}_4$ + M/200 KCl	0.062 volt	} 0.042 volt
60	M/40 $\text{CuSO}_4$ + M/40 KCl	0.020 volt	
64	M/40 $\text{CuSO}_4$ + M/40 KCl	0.019 volt	
84	M/40 $\text{CuSO}_4$ + M/20 sugar (No KCl)	0.126 volt	

The change of the electromotive force is perfectly reversible and it cannot be due to a change of the "liquid potential" at the junction of the calomel electrode and the

<sup>1</sup> Diluted with M/10 grape-sugar in *all* following experiments even when not mentioned.

beaker. On account of the equality of migration velocity of  $K^+$  and  $Cl^-$  this "liquid potential" must be nearly zero and can vary but slightly with the concentration. The only other place where it can be located is at the junction of the membrane and the solution. The sense of the change is such that the *membrane behaves like an electrode reversible for  $K^+$  ions*. If we try to apply Nernst's formula

$$\text{Pot. diff.} = \frac{RT}{nF} \ln c. + \text{const}$$

which holds for any reversible electrode, we find that if  $n = 1$  and if  $c$  is varied in the ratio 1 : 5 (as in the above experiments), the potential difference at room temperature should vary 0.040 volt; the values observed may be considered a good confirmation.

I think that from these experiments it is possible to explain why the cell

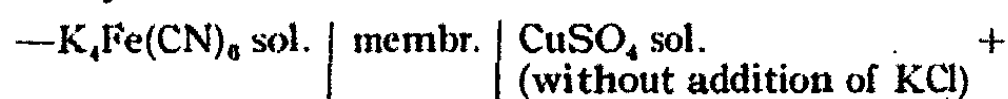

has an electromotive force as was observed. It is *due to the effect of  $K^+$  ions of the  $K_4Fe(CN)_6$  acting on the opposite (gelatine) side of the membrane*. What we really observe is a "concentration cell" with respect to  $K^+$

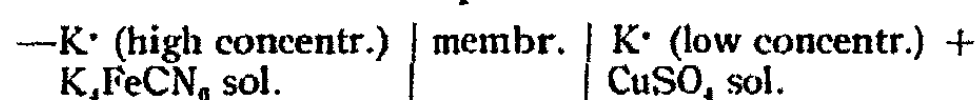

The  $CuSO_4$  must contain traces of  $K^+$  salt (or  $K^+$  ion)—even if chemically pure—on account of the fact that by the chemical reaction which forms the membrane  $K^+$  salt is set free.

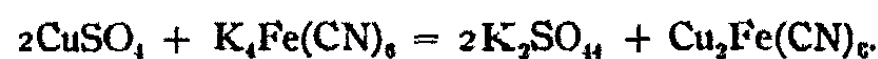

The  $K_2SO_4$  formed will be present most likely on both sides of the membrane. On the side of the  $CuSO_4$  solution in the beaker it is quickly diluted by diffusion into the great volume of the  $K^+$  free solution. The concentration of  $K^+$  is however not very well defined on the surface between membranes and solution (in the beaker) and this is most likely the reason why the electromotive force of the cell is rather inconstant.

7. If we stir the solution in the beaker or shake it slightly (while no KCl is added) we find a distinct but inconstant rise of the electromotive force. The following observations may serve to elucidate this fact.

SOLUTION IN THE BEAKER M/40  $\text{CuSO}_4$  + M/20 GRAPE SUGAR

Time in minutes	Volt
0	0.110
10	0.116
beaker shaken 12	0.139
	electromotive force diminished, while the solution is <i>not</i> moved.
33	0.120
37	0.122

The effect of shaking apparently is due to an acceleration of convection, thus the  $\text{K}^+$  concentration at and in the vicinity of the membrane becomes smaller; this must increase the electromotive force of the system if our conception is right that the "cell" really is a concentration cell for  $\text{K}^+$ .

8. But how is the decrease of the electromotive force to be explained, which occurs if the solution is left unshaken? We can understand this from observations of a different type which relate to the *growth of the membrane*.

The membrane forms a very thin skin at the end of the first day after the system has been put together but is undergoing a constant process of growth, as is clearly seen after about two or three days, when the membrane has grown to a thickness of about 1 mm. Apparently this growth would be impossible if the membrane were perfectly impermeable for both salts,  $\text{K}_4\text{Fe}(\text{CN})_6$  and  $\text{CuSO}_4$ , from which it is generated.<sup>1</sup>

The effect of diffusion of  $\text{K}_4\text{Fe}(\text{CN})_6$  through the membrane seems to be as follows:

<sup>1</sup> Walden: Zeit. phys. Chem., 10, 699 (1892) finds that a copper ferrocyanide membrane is impermeable for both  $\text{K}_4\text{Fe}(\text{CN})_6$  and  $\text{CuSO}_4$ . This however may only mean that the permeability is small. The rather slow growth of the membrane indicates that in this sense Walden's statement is right.

$K_4Fe(CN)_6$  will pass into the membrane at one surface and diffuse through the membrane to the other surface, where the chemical reaction with  $CuSO_4$  takes place;  $K_2SO_4$  is therefore generated at the surface of the membrane in contact with that of the  $CuSO_4$  solution. It will diffuse into this latter because of its greater solubility in water than in the membrane. All  $K_2SO_4$  formed by the reaction will be formed at the surface of the membrane if the  $CuSO_4$  does *not* diffuse through the membrane. If this *is* the case, the reaction between  $K_4Fe(CN)_6$  and  $CuSO_4$  must take place in the membrane itself and the  $K_2SO_4$  formed will diffuse to both surfaces. Whether the latter is true or whether  $K_4Fe(CN)_6$  *only* diffuses is unessential for our experiments. All  $K_2SO_4$  will be formed at the surface of the membrane in contact with the ferrocyanide solution, if the membrane is permeable for  $CuSO_4$  *only*, but this is not likely to be the case.

We can now understand how  $K^+$  salt is constantly being formed at the membrane; this small quantity of  $K^+$  is most likely essential for the electromotive force. I do not know however whether under certain circumstances the  $CuSO_4$  also may influence the electromotive force. If the  $K^+$  concentration is kept very low, it is possible that the cell may no longer act like a mere concentration cell for  $K^+$ ; but may act like a cell, the electromotive force of which is due to a chemical reaction. Such is however not the case in all experiments communicated to this paper.

9. Another proof, for the fact that  $K^+$  ions formed through the growth of the membrane determine the electromotive force, is found in the following facts: If we arrange the experiment described above in such a way that the  $CuSO_4$  solution is mixed with 10 percent gelatine and placed in the (upper) tube while the beaker contains the  $K_4Fe(CN)_6$  solution (compare Fig. 1) *scarcely any electromotive force at all is observed.*

I first tried to explain this observation by means of the assumption that the gelatine may possess an action upon the

potential difference like KCl, or that the commercial gelatine used may contain alkali salts as impurities. Neither assumption can be right as no action of the gelatine at all was observed, when, with the first arrangement:



some gelatine was added to the solution in the beaker.

I think it is very likely that the  $\text{K}_2\text{SO}_4$  formed through the growth of the membrane is the cause for the fact that the electromotive force of the "cell"



is nearly zero.<sup>1</sup> The  $\text{K}_2\text{SO}_4$  formed in the boundary region of the  $\text{CuSO}_4$  solution is kept there in a high concentration as the convection is retarded by the gelatine. Therefore, the concentration of  $\text{K}^+$  is nearly equal on both sides of the membrane.

I wish to add that with this cell no considerable effect upon the electromotive force can be expected through addition of further alkali salt to the  $\text{K}_4\text{Fe}(\text{CN})_6$  solution, as the  $\text{K}^+$  concentration is thus varied only slightly. This was also confirmed by experiment.

If the  $\text{K}_4\text{Fe}(\text{CN})_6$  concentration was varied, the electromotive force underwent small changes.

10. Furthermore, some measurements of the cell



were performed while *no*  $\text{CuSO}_4$  was added. For the reasons given above, the electromotive force is not exactly reversible in this case (compare page 349).

<sup>1</sup> The values observed were 0.003 to 0.010 volt.

Time in minutes	Solution in the beaker	E. m. f.	Difference
0	M/20 KCl	0.003 volt	
1	M/20 KCl	0.003 volt	}0.038 volt
7	M/100 KCl	0.041 volt	
10	M/100 KCl	0.039 volt	}0.037 volt
12	M/500 KCl	0.076 volt	
14	M/500 KCl	0.076 volt	}0.025 volt
16	M/2500 KCl	0.101 volt	
19	M/500 KCl	0.072 volt	0.029 volt
22	M/500 KCl	0.071 volt	}0.033 volt
23	M/100 KCl	0.038 volt	
24	M/100 KCl	0.037 volt	}0.034 volt
30	M/20 KCl	0.003 volt	

11. As was said above (compare page 345), the membrane is not reversible for K<sup>+</sup> ions only, but for other ions in the same way. In other words, the electromotive force is changed in the same way if NaCl or Na<sub>2</sub>SO<sub>4</sub> be added to the CuSO<sub>4</sub> solution in the beaker instead of KCl, as the following measurements show:

Time in minutes	Comp. solution in the beaker	E. m. f.	Difference of e. m. f.
0	M/40 CuSO <sub>4</sub>	0.125 volt	
2	M/40 CuSO <sub>4</sub> + 1/80 Na <sub>2</sub> SO <sub>4</sub>	0.035 volt	
7	M/40 CuSO <sub>4</sub> + 1/80 Na <sub>2</sub> SO <sub>4</sub>	0.028 volt	
11	M/40 CuSO <sub>4</sub> + 1/80 Na <sub>2</sub> SO <sub>4</sub>	0.031 volt	
15	M/40 CuSO <sub>4</sub> + 1/40 NaCl	0.032 volt	
21	M/40 CuSO <sub>4</sub> + 1/40 NaCl	0.030 volt	}0.051 volt
26	M/40 CuSO <sub>4</sub> + 1/40 NaCl	0.028 volt	
31	M/40 CuSO <sub>4</sub> + 1/40 NaCl	0.079 volt	}0.0515 volt
34	M/40 CuSO <sub>4</sub> + 1/400 NaCl	0.080 volt	
36	M/40 CuSO <sub>4</sub> + 1/400 NaCl	0.080 volt	
46	M/40 CuSO <sub>4</sub> + 1/40 NaCl	0.0285 volt	
48	M/40 CuSO <sub>4</sub> + 1/40 NaCl	0.0285 volt	

The fact that Na<sub>2</sub>SO<sub>4</sub> and NaCl influence the electromotive force in exactly the same way shows that the Cl<sup>-</sup> ion of NaCl or KCl does not have any specific action. The change of the electromotive force for a tenfold dilution should be 0.058 volt according to Nernst's formula.

The following measurements relate to  $\text{NH}_4\text{Cl}$ :

Time in minutes	Comp. of solution in the beaker	E. m. f.	Difference of e. m. f.
0	M/40 $\text{CuSO}_4$	0.105 volt	
3	M/40 $\text{CuSO}_4$ + 1/40 $\text{NH}_4\text{Cl}$	0.024 volt	
5	M/40 $\text{CuSO}_4$ + 1/40 $\text{NH}_4\text{Cl}$	0.021 volt	} 0.053 volt (calc. 0.05)
7	M/40 $\text{CuSO}_4$ + 1/400 $\text{NH}_4\text{Cl}$	0.074 volt	
9	M/40 $\text{CuSO}_4$ + 1/400 $\text{NH}_4\text{Cl}$	0.073 volt	} 0.053 volt
10	M/40 $\text{CuSO}_4$ + 1/40 $\text{NH}_4\text{Cl}$	0.021 volt	
10	M/40 $\text{CuSO}_4$ + 1/40 $\text{NH}_4\text{Cl}$	0.020 volt	
27	M/40 $\text{CuSO}_4$	0.109 volt	

HCl also had a distinct influence on the electromotive force, as the following experiments prove:

Time in minutes	Comp. of solution in the beaker	E. m. f.	Difference of e. m. f.
0	M/40 $\text{CuSO}_4$ + 1/40 $\text{NaCl}$	+0.029 volt	
12	M/40 $\text{CuSO}_4$ + 1/40 $\text{HCl}$	-0.035 volt	(solution at negative pole)
19	M/40 $\text{CuSO}_4$ + 1/40 $\text{HCl}$	-0.004 volt	} 0.046 volt
20	M/40 $\text{CuSO}_4$ + 1/400 $\text{HCl}$	+0.042 volt	
29	M/40 $\text{CuSO}_4$ + 1/400 $\text{HCl}$	+0.041 volt	
37	M/40 $\text{CuSO}_4$ + 1/400 $\text{HCl}$	+0.043 volt	} 0.037 volt
39	M/40 $\text{CuSO}_4$ + 1/4000 $\text{HCl}$	+0.080 volt	
40	M/40 $\text{CuSO}_4$ + 1/4000 $\text{HCl}$	+0.079 volt	} 0.036 volt
42	M/40 $\text{CuSO}_4$ + 1/400 $\text{HCl}$	0.043 volt	
48	M/40 $\text{CuSO}_4$ + 1/400 $\text{HCl}$	0.042 volt	} 0.044 volt
48	M/40 $\text{CuSO}_4$ + 1/40 $\text{HCl}$	-0.002 volt	
50	M/40 $\text{CuSO}_4$ + 1/40 $\text{HCl}$	-0.003 volt	

The quantitative application of Nernst's formula seems to be less satisfactory in the last measurements (relating to HCl), the value calculated (0.058 volt) differing considerably from those observed. It must be said, however, that in this case the "liquid potential" at the junction of the left (see Fig. 1) electrode is neither zero nor practically independent of the HCl concentration on account of the great migration velocity of  $\text{H}^+$  ions.



The sign of the "liquid potential" is opposed in this case to the sign of the potential difference at the membrane; this may account for the observation of too small differences as compared with the theoretical value. A quantitative calculation, however, seems impossible for the reason that the considerable amount of sugar present in some solutions is not without influence upon "liquid potentials."<sup>1</sup>

*Bivalent cations seem to have no influence upon the electromotive force* if added to the solution in the beaker, as the following measurements show:

	Solution	E. m. f.
I	M/40 CuSO <sub>4</sub>	0.123 volt
	M/40 CuSO <sub>4</sub> + 1/40 CaCl <sub>2</sub>	0.130 volt <sup>2</sup>
II Time in minutes		
0	M/40 CuSO <sub>4</sub>	0.109 volt
2	M/40 CuSO <sub>4</sub> + 1/40 MgCl <sub>2</sub>	0.122 volt <sup>1</sup>
3	M/40 CuSO <sub>4</sub> + 1/40 MgCl <sub>2</sub>	0.119 volt
4	M/40 CuSO <sub>4</sub> + 1/40 MgCl <sub>2</sub>	0.118 volt
5	M/40 CuSO <sub>4</sub> + 1/400 MgCl <sub>2</sub>	0.128 volt
6	M/40 CuSO <sub>4</sub> + 1/400 MgCl <sub>2</sub>	0.126 volt
7	M/40 CuSO <sub>4</sub>	0.126 volt

As to bivalent cations the artificial membrane seems to behave distinctly differently from tissue membrane, at least so far as observed by Dr. Loeb and the writer. It was found<sup>3</sup> that the potential differences at the skin of plants are influenced by CaCl<sub>2</sub> solutions nearly in the same way as by KCl or NaCl solutions.

12. The observations described prove that an artificial membrane acts like an electrode, reversible for monovalent

<sup>1</sup> This fact is not accounted for by the well-known theory of "liquid potentials" by Planck and Nernst. By experiments of Oker-Blom (Pflüger's Archiv., 84, 191), however, an influence of non-electrolytes upon liquid potentials is clearly demonstrated.

<sup>2</sup> This small rise of the electromotive force is not reversible and most likely more or less accidental.

<sup>3</sup> Loc. cit.

ions of different kinds in a similar way as a tissue membrane acts. As to the further question, as to what circumstances may possibly bring about this electromotive effect, I think that the same explanation can be given here as for potential differences at tissue membrane. For the latter I have proved in a mathematical paper<sup>1</sup> that the following relation holds:

$$\text{Pot. diff.} = 0.058 (\log C - \log \{1 + \sqrt{1 + 10^6 m^2 C^2}\} + \text{const.})$$

where pot. diff. is expressed in volts at room temperature,  $C$  is the concentration of the aqueous solution, and  $m$  is given by the following relation:

$$0.058 \log 1/m = \text{limiting value of the pot. diff. for } C = n/500.$$

The potential difference in fact reaches a limiting value at high concentrations in this case, *i. e.*, the electromotive force of a cell:

Concentrated solution | tissue membrane | dilute solution

becomes zero, if the concentration of the (more) dilute solution is higher than a certain value. The formula was tested experimentally by means of measurements on apples and was found to agree well with the observations.

No limiting value of the potential difference was observed with the potential differences investigated in this paper, but this may be due to the fact that the concentration could not be increased high enough to reach the limiting value. I intend to investigate this point further.

The derivation of the formula cited above was based primarily upon the fact that the junction between any two phases behaves like an electrode, *i. e.*, that the potential difference located there can be expressed as

$$\frac{RT}{nF} \ln \frac{c_1}{c_2} \text{ const.}$$

where  $c_1$  is the concentration of an ion common to both phases

<sup>1</sup> Presented at the Eighth International Congress of Applied Chemistry in New York, Vol. 22, 29 (1912). A communication of the same paper is also found in the *Biochem. Zeitschrift*, 47, 73 (1912.)

in the one phase,  $c_2$ , the same in other place.<sup>1</sup> Furthermore, the following assumptions were made:

*a.* That a complete reaction takes place between a constituent of the membrane and the aqueous solution. In this reaction a salt is formed which is insoluble in water but distributed in the membrane homogeneously.

*b.* That the electrolyte as such is contained in the membrane in small concentration and that in accordance with the law of partition the ratio of concentration of electrolyte in membrane and in water is constant. The details of the derivation will be found in the cited mathematical paper.

The main point proved by the agreement of the observations with this mathematical theory is *that the membrane contains a water-insoluble electrolyte of the same cation for which it is reversible*. I am inclined to believe that with the copper ferrocyanide membrane this water-insoluble electrolyte in the membrane is a complex compound of copper ferrocyanide and alkali ferrocyanide, *i. e.*, the membrane is not copper ferrocyanide as indicated by the formula  $\text{Cu}_2\text{Fe}(\text{CN})_6$  but contains alkali salt also.

This alkali salt is Na, K, or  $\text{NH}_4$  salt according to the composition of the aqueous solution; this is possible on account of a chemical reaction which takes place between the alkali salt of the membrane, *i. e.*,  $\text{KX}$  and the alkali salt of the solution, *i. e.*,  $\text{NH}_4\text{Cl}$ , whereby  $\text{NH}_4\text{X}$  (in the membrane) and  $\text{KCl}$  is formed.

13. The theory explained seems to be very hypothetical on account of the fact that neither the exact chemical constitution nor the physical properties of the membrane are known to a satisfactory extent. Further evidence of the real nature of these new electric phenomena is however gained through *the new galvanic phenomena with water-insoluble organic liquids which the author first observed recently*. It was found that water-insoluble liquids of an acid character ex-

<sup>1</sup> Concerning the derivation of this formula (which was first derived for a special case by Nernst), I refer to my paper, *Trans. Am. Electrochem. Soc.*, 21, 219 (1912).

hibit an electromotive force like the membranes described; water-insoluble bases, however, exhibit a change of the potential difference in the opposite direction.

With experiments of this kind the composition of the second phase (*i. e.*, the water-insoluble liquid which replaces the membrane in our experiments) *was* known, as well as some of its physical properties. In a great number of experiments, in which both the composition of the second phase as well as the composition of the aqueous solution was varied, the assumptions described above were found to be correct; the physical conditions which cause potential differences reversible for more than one ion, are mainly due to the formation of a water-insoluble compound by a chemical reaction between the aqueous electrolyte and a constituent of the second phase.<sup>1</sup>

I think that a study of membranes of various compositions, which I intend to perform, will give further evidence concerning these questions.

#### Conclusions

The main results of the experiments described are:

1. A precipitation membrane of copper ferrocyanide behaves like an electrode, reversible for monovalent positive ions of different kinds.

2. The electromotive force of the system  $K_4Fe(CN)_6$  aq. sol.—precipitation membrane— $CuSO_4$  aq. sol. is due to a concentration cell with  $K^+$  ions. The  $K^+$  salt concentration of the  $CuSO_4$  solution is due to  $K_2SO_4$ , which is generated by the formation and steady increase in thickness of the membrane. The  $K^+$  concentration in the boundary region of the  $CuSO_4$  solution, which is essential for the electromotive force, depends mainly on the velocity of diffusion into that part of the  $CuSO_4$  solution which is free from  $K_2SO_4$ .

*Biological Department  
Rockefeller Institute for Medical Research  
New York*

<sup>1</sup> As to further details of this investigation, I refer to a publication which is soon to appear in the Transactions of the Am. Electrochem. Soc.

## NEW BOOKS

**Die Existenz der Moleküle.** By The Svedberg. 18 × 25 cm; pp. v + 239. Leipzig: Akademische Verlagsgesellschaft, 1912. Price: 12 marks.—In the introduction the author says:

"What do we mean, scientifically speaking, by proof of the existence of a thing? Let us consider a vessel, filled with water, to which a little sand has been added. We can see the grains of sand and, therefore, we have no doubt, scientifically speaking, that there are material particles in the vessel. The reason that the existence of the particles is so self-evident to us is that it seems impossible for us to account for what we see in any other way than by the assumption of material particles in the water. Suppose that we add a little clay to the water and rub it in thoroughly. We now have a turbid, gray liquid in which no separate particles are to be seen. If we examine a drop of this liquid under a microscope, a large number of small particles become visible. In this case there is also no doubt in our minds but that there are discrete particles in the gray mixture of water and clay. Suppose we now take some water (which must be very pure) and add a few drops of a gold trichloride solution and then a few drops of hydrazine bichloride. On addition of the reducing agent, the dilute, colorless solution of gold chloride changes to an intensely colored liquid, a colloidal solution of gold, in which no separate particles are to be seen either with the naked eye or under the strongest microscope. However, if an intense ray of light be made to fall on the colored liquid and if we look at the illuminated portion through a microscope in a direction perpendicular to the path of the beam—in other words, if we use the so-called ultra-microscope of Siedentopf and Zsigmondy instead of the ordinary microscope—we see an enormous number of small points of light. If we use the ultra-microscope on the mixture of water and clay in which we saw discrete particles by means of the ordinary microscope, we see a number of shining points which are, however, much brighter than in the case of the gold solution. By counting we can determine how many points of light there are in a given volume. If we do this, we find that the number thus obtained is identical with the number of separate particles seen in the same volume when using the ordinary microscope. Starting from these facts, the scientific man is justified in drawing the conclusion that material particles are also present in the colloidal solution. There is nothing in the laws of logic to prevent two different causes giving rise to similar phenomena, such as the points of light as shown by the ultra-microscope in the colloidal gold solution and in the clay suspension. The scientific man finds a support and justification for his conclusion in the fact that he is not able at present to find any other explanation for the appearance of the points of light in the colloidal gold solution. Let us now consider a still more difficult case. Suppose we add a few drops of a solution of phosphorus in ether to a very dilute, slightly alkaline, solution of gold trichloride. In the course of a few hours, the colorless solution of gold chloride changes to a beautiful ruby-red liquid. In this liquid it is not possible to detect discrete particles even by means of the ultra-microscope. Nevertheless, scientific men are unanimous in believing that this liquid also contains a

large number of small particles of gold. This conclusion is based on an argument by analogy. The properties of the gold solution in question differ chiefly in degree from those of the solution in which the ultra-microscope showed the existence of discrete particles and, therefore, it is very probable that both solutions contain discrete particles. It is a simple matter to account for not being able to see the particles in the one solution by the assumption that they are too small to be detected even with the aid of the ultra-microscope.

"This illustration may serve as an answer to the question as to the nature of a scientific proof of the existence of a thing. All the experimental proofs of the existence of molecules rest on similar reasoning. Whenever we find a phenomenon which cannot be brought into line with our scientific conceptions of the world except by assuming that matter is made up of small, discrete particles, we have furnished an experimental proof for the existence of molecules. It is admitted that all proofs for the existence of molecules are valid only so long as we can give no better explanation of the phenomena than that offered by the molecular theory. From a theoretical point of view it is a matter of indifference whether the proof depends on making the molecules actually visible as was done for the colloidal particles by means of the ultra-microscope, or whether it is based on any other phenomena. Practically, however, the making a thing visible is a more satisfactory proof of its existence than any other method because such a proof involves the fewest assumptions and depends on thoroughly familiar phenomena.

"From the atomistic view-point all phenomena, which depend on the action of atoms and molecules, may be classified as multimolecular and paucimolecular. Under the first heading we have the phenomena in which a large number of atoms or molecules take part, while the second group contains the phenomena in which only a few atoms or molecules are active. The data in this volume are classified according to this division."

The author has made colorimetric measurements on solutions of colloidal gold, colloidal ferric oxide, and colloidal arsenic sulphide. He sums up his conclusions, p. 29, as follows:

"The enormous gap which appeared to exist between the intensity of color of colloidal solutions and that of the closely allied molecular solutions has been bridged, because I have shown that the intensity of color of the colloidal solutions decreases continually with decreasing size of particles—at any rate, after passing a certain point. In certain cases I was able to show that with decreasing size of particles, the intensity of color finally approaches very closely to that of the allied, molecular-disperse, system. It is, therefore, very probable that the decrease in the intensity of color with decreasing size of particles, which occurs beyond a certain point in the ultra-microscopic region, continues all the way to molecular solutions. Reasoning from continuity, it follows that molecular solutions probably consist of discrete particles."

The conclusion may be right but the reasoning is not. Quite regardless of whether true solutions contain discrete particles, they must appear as the end term of colloid suspensions in which the particles are made continuously smaller. The solubility of the particles in a suspension increases with decreasing size of the particles and becomes very large for a certain size. With

continuously decreasing size of particles, the actual solubility increases until there are no particles left. Because we can pass from a crystalline salt to a dilute solution by adding water continuously to a definite amount of salt, we do not conclude that we have a crystalline structure in the solution, though it is possible that we may have one.

The author has also made spectrophotometric measurements and diffusion measurements with a number of colloidal solutions prepared so as to give a continuously decreasing size of particles. By the same faulty reasoning he draws the same conclusions that he drew from his colorimetric measurements.

The second half of the book is devoted to experiments on the Brownian movements and on the spontaneous variations of concentration in radioactive solutions and gases. The book is a remarkable one as a collection of experimental data and is to be recommended highly on this ground. *Wilder D. Bancroft*

**Triumphs and Wonders of Modern Chemistry.** By *Geoffrey Martin*. 14 X 20 cm; xx + 358. New York: D. Van Nostrand Co., 1911. Price: \$2.00.—

In the preface the author says:

"Within the last few years chemistry has been revolutionized by startling discoveries which have followed one another in quick succession, and these are briefly described in the following pages. The atoms have been shown to be of immense complexity, the seat of vast forces and terrific motions, the very existence of which was scarce dreamt of until the advent of radium. A series of magnificent researches has recently shown us that these atoms, far from being the changeless and eternal foundation stones of the universe that they were once thought to be, are themselves crumbling away. Such conceptions and discoveries have altered the whole aspect of chemistry, and have necessitated the treating afresh of many old problems previously regarded as settled.

"It has been my lot while lecturing on chemistry to have come into frequent contact with many thoughtful men and women, boys and girls, who have felt much interest in this new chemistry, which has arisen out of the old, and who have wished to know something more of the grand questions of the day touching the ultimate nature and constitution of the Universe in which they live, and of the matter which surrounds them on every side in untold millions of tons, but who have neither the leisure nor the inclination to master the technicalities and enter into the minutiae of the regular text-books of chemistry where such things are discussed. These text-books, moreover, labor under the disadvantage that they are written for candidates studying for one or other of the innumerable examinations in which our university authorities take such keen delight, and which, combined with a complete lack of educational freedom, make an English University student's life a perfect nightmare to him (in sad contrast to that of the German or American student), and destroy rapidly and effectively any genuine interest in science that he may have possessed at his entrance to the university, besides exercising a paralyzing effect on the university lecturers themselves, and diminishing greatly the output of research work in this country, to its incalculable material and moral harm.

"This book is not written for examination candidates. It is written in order to awaken the interest of the general reader and the young student in what

is after all a *grand* science; for chemistry is the science which tells us that Nature works by unscen bodies—by myriads of tiny atoms whirling in gigantically swift and infinitely complex motion, the whole forming a microcosmic world beneath the visible world—and that her true laboratory consists of 'events in inconceivable numbers, the whole phantasmagoria of these events changing every instant down to its minutest details with inconceivable rapidity.' The most insignificant objects are fraught with endless wonder and mystery. A breath of wind is the swift rush of millions of atoms, the blazing of a match the destruction of a universe almost infinite in complexity and the building up of a new one out of its ruins, while in the tiniest grain of dust dancing in a sunbeam the rush of atomic events in the millionth part of a second is so incredibly swift as to defy all conception and calculation. Indeed, the whole universe, from its uttermost heights to its deepest depths, is but one vast system in a state of ceaseless and stupendous chemical change. This book represents an effort to give the general reader a picture of the world in which the chemist wanders, and an idea of the great and wonderful problems with which modern chemistry deals. At the same time it is hoped that the book will prove useful both to *popular lecturers* and to *chemistry teachers* in need of interesting illustrative facts for their routine chemical classes."

The chapters are entitled: the mystery of matter; the underworld of atoms; distribution and evolution of the elements; the wonders of chemical change; water; the element hydrogen; the air; oxygen, the life-supporting element; the element nitrogen; the element carbon; carbon dioxide; silicon and its compounds; sulphur and its compounds; the phosphorus group of elements; fire, flame, and spectral analysis.

We all agree that the layman should know more about chemistry than he does, and we all ought to regret that the chemist's manner of thinking and talking makes it impossible for him to discuss his subject with anybody except another chemist. All attempts to bridge this gulf are praiseworthy. Duncan has tried it and now we have another attempt in a rather flamboyant manner.

On p. 67 we find a characteristic sample, while a second quotation, p. 98, seems to show what the author might have done.

"Let us now illustrate the utility of these chemical symbols for expressing chemical changes. If we throw a pinch of chalk dust into hydrochloric acid, we see a momentary effervescence, which passes and leaves the acid apparently much as it was. No striking outward phenomena have occurred to awaken our surprise or challenge our attention. Yet in this instant of time a wonderful change has taken place. Nothing less, indeed, than the destruction, swift and terrible, of a whole atomic universe. The chalk as it falls into the acid represents the intrusion of one vast stream of whirling atomic systems into another equally vast stream. In an instant millions upon millions of chalk molecules are colliding with equally vast numbers of hydrochloric acid molecules. Each time a molecule of chalk encounters a molecule of hydrochloric acid, both tiny atomic systems are irretrievably shattered and their fragments rearrange themselves into other atomic systems. The slight effervescence noticed marks the swift rush of one series of these rearranged atoms, in the form of a colorless gas called carbon dioxide, whose molecules consist of two atoms of oxygen whirling



round one atom of carbon. Water molecules and calcium chloride molecules are similarly born, and go whirling off among the mass of molecules which constitute the hydrochloric acid. Thus an event, one of innumerable other similar events taking place ceaselessly around us, apparently so insignificant as to scarce merit our attention, really represents a stupendous catastrophe in the atomic universe. At first sight it would seem incredible that all the bewildering complexity and intricate detail which necessarily attends the collision of billions of atomic systems, each collision being accompanied by its own train of events which distinguish it from all the others, could ever be simply and concisely expressed by chemists. Yet chemists, by means of their symbolical language, not only do this, but they actually express the final result quantitatively."

"Water is an almost incompressible fluid, one million volumes diminishing by only fifty when the atmospheric pressure is doubled. Slight as this compressibility may seem to us, yet, as Prof. Tait has shown, it produces most important results. At the bottom of the dark abysses of the ocean, nearly six miles deep, the pressure must amount to 1000 atmospheres. The result of this compression is to make the surface-level of the general mass of the oceans some 116 feet lower than it would be if the water were perfectly incompressible. If water suddenly ceased to be compressible the great oceans would instantly rise 116 feet in height and pour in a mighty flood over low-lying lands. Over 2,000,000 square miles of land, something like 4 percent of the whole land area of the globe, would be submerged by the torrent, the hills appearing above the waters as small islands."

In spite of the continuous beating of the bass drum, the author has written a very readable book. The illustrations are unusually bad, one of the worst, p. 23, showing a man gazing down a microscope with one eye, while the other eye looks reproachfully at the reader.

Wilder D. Bancroft

**Refractories and Furnaces.** By F. T. Havard. 16 X 23 cm; pp. 333. New York: McGraw-Hill Book Company, 1912. Price: \$4.00.—The author is now associate professor of metallurgy at the University of Wisconsin and consulting metallurgist to Goldsmith Bros. Smelting and Refining Co. He has formerly been connected with The Boston and Montana C. C. and S. C., The West Prussian Mining Co., The Copiapo Mining Co., Ltd., and The U. S. Metals Refining Co., which gives him a fairly varied experience.

In the preface the author says:

"Some notes on furnace linings, breasts and packings, made during the author's activities as superintendent of furnaces, formed the original basis in the preparation of this book. But since no serious effort has ever been made to collect the scattered information on the properties and preparation of the materials of which industrial furnaces are constructed, considerable space has been devoted to descriptions of the sources, and processes of manufacture, of refractories with the object of presenting, to those interested in refractory materials and in the operation of furnaces, a comprehensive study of the physical and chemical properties of these materials.

"The author has attempted also to coördinate the study of methods of preparing and testing refractory materials and of constructing furnaces, and has tried to systematize the data on the many kinds of cements, and packing and fettling mixtures which have their usefulness under special conditions in promoting efficiency in furnace campaigns and in reducing the ever-high cost item of furnace repairs and masonry."

The headings of the chapters are: classification of refractory materials; the relation between slags and refractory vessels and linings; the preparation of the silicious refractories; the preparation of the refractory clays; the preparation of the basic and neutral refractories; the use of refractory materials in the metallurgy of iron and steel; refractories used in the metallurgy of copper; refractories used in the metallurgy of lead and silver, and in general metallurgical practice; refractories used in the chemical and electrometallurgical industries; some instances of application of common and refractory bricks in industrial furnaces; directions in constructing furnaces; refractory hollow ware; testing of refractory products and refractory raw materials; the thermo-physical properties of furnace materials; heat measurements in the metallurgical and refractories industry; the preparation of common brick.

The author classifies refractories, p. 19, as acid, basic and neutral refractories. Acid refractories may be silicious materials depending on the infusibility of pure silica; they must therefore be high in silica and low in metal oxides and alkalis. They may also be alumino-silicious materials, which depend for their refractoriness on the infusibility of aluminum silicate. Such must contain but little free silica, since an excess lowers the fusing-point. Basic refractories consist essentially of alumina, lime or magnesia. Under neutral refractories are grouped: steatite, chromite, and possibly cement; charcoal, coke, and graphite; the synthetic compounds of carbon and silicon; iron, platinum, nickel, etc.; the asbestos refractory hatches and paints.

The author has the following to say, p. 48, in regard to silica bricks.

"Owing to their porous character silica bricks are light, brittle and not easily worked. They are only fair conductors of heat, break if heated with insufficient regularity, and under rapid change in temperature they become friable and crack. They are easily attacked by basic slags, metal oxides and flue dust. They are the best of all fire bricks to employ where constant high temperatures are used and where acid slags are produced. They are superior to fire-clay bricks in that they expand regularly at high temperatures. This is of value wherever mortar is used and especially in crowns and arches, for fire-clay bricks expand scarcely at all, and all mortars shrink. The commonly accepted axiom that a fire-clay brick shrinks on using in industrial furnaces must be modified. As a rule it expands somewhat when the furnace is in heat, but contracts considerably from its original dimensions when the furnace is cooled.

"On account of the high modulus of expansion of the silica brick they must not be laid too closely. Tie bars must be slackened as the bricks expand, and, to minimize danger of cracking the fire-brick, walls and roof must be heated gradually, evenly and slowly. The best mortar to use is ground silica brick in a little fire clay, or quartz sand mixed with lime."

Of the basic and neutral refractories, p. 88, magnesia "is probably the most widely-used refractory, with the greatest possibility of more varied application, and yet often most disappointing to the baffled operator. Some magnesia products spall at fairly low temperatures, crack when a metal bath laps against their sides, or crumble when subjected to changes in temperature, while others withstand such tests and also the influences of high temperature and active slags. This varying conduct is due to differences both in the chemical composition and in physical structure of the raw materials, and also to the method of grinding, tempering and bonding and to the conditions governing the drying and burning. Within the last few years, with growing knowledge of its physical properties, the preparation of magnesite for the industry has been more careful. The results have been such that the application in different fields is growing rapidly. The magnesia-bearing minerals, magnesite, serpentine, soapstone and steatite, have been used for many years, in the raw, calcined and prepared state, as setting for furnaces, either alone or in mixtures with such additions as fire clay. For instance, in Europe Styrian magnesite has long been used in an admixture with fire clay; from the mixture, bricks have been formed, burned at a high temperature and used in iron, glass and other industries. Serpentine, containing 44 percent  $\text{SiO}_2$ , 43 percent  $\text{MgO}$  and 13 percent water, was a favorite lining for basic charges in Styria. Even for the linings of the old puddle furnaces of Dornawitz, magnesia bricks were regarded with favor."

"The value of magnesia in the form of mass, bricks and crucibles depends on the infusibility and resistance to chemical action of pure magnesia. Now, commercially pure magnesia may be obtained only by calcining magnesite at very high temperatures. The material, obtained by calcining in the electric furnace at  $2000^\circ\text{C}$ , is a very satisfactory product and, when made into bricks, or crucibles, has a relatively longer life when exposed to the influences of severe heat and chemical attacks. A crucible, made by moulding the ordinary magnesia resulting from incomplete calcination of magnesite in industrial furnaces, when subjected to a temperature of  $2000^\circ\text{C}$ , sinters so that the walls and bottom become dense and tough. That same crucible will soften again and become difficult to handle when exposed to any high temperature. The ordinary magnesia bricks are burned at a temperature which turns cone 29 ( $1710^\circ\text{C}$ ). It is a satisfactory refractory material in the lining of a commercial furnace which works at or below a temperature of  $1600^\circ\text{C}$ , but softens and spalls when subjected to a high temperature.

"It always has a tendency to combine with acid materials but becomes particularly active at high temperatures. Accordingly, any tests to determine the temperature of softening, or other qualities of magnesia, should be made in a magnesia or neutral vessel, since it fuses at a lower temperature than the real softening point when in contact with fire clay or acid material with which it forms a relatively fusible salt. With regard to the influence of the physical and chemical properties of the raw material, it is interesting to note that the Styrian magnesite is generally held in higher regard by refractories manufacturers than the Grecian mineral. The Styrian is a crystalline or spathic mineral; the Grecian magnesite is found in an amorphous mineral. The former contains more

impurities, especially peroxide of iron. The particular combination of impurities present in the Styrian variety serves, in burning, to sinter and knit the whole brick or other shape together, just as the basic impurities in the Pennsylvania and Wisconsin quartzites help, by their combination with silica, to cement the whole brick or form together. The special value of the crystalline structure depends on the mineral grinding to a grain of heterogeneous form, whereas the amorphous mineral, on crushing, falls in part to dust. The fine dust particles or even grain are difficult to hold in bond."

On p. 200 we read that "it is obvious that the tendency to cracking exhibited by the ordinary calcined magnesite is less likely to be found in a material which has been calcined at the very much higher temperatures attainable by electric means. An experiment which brought this out very clearly was as follows: A crucible was made of highly calcined magnesia prepared from Grecian magnesite. The crucible was embedded in a granular carbon resistor and the current regulated so as to heat the crucible very gradually. The crucible was finally raised to an intense white heat, probably about 1500° C, and was then allowed to cool gradually in the furnace. It was so badly cracked that it was absolutely useless. Another crucible was made in exactly the same way except that electrically calcined magnesia was used. This crucible was heated fairly rapidly to a temperature at which Seger cone 35 (supposed to bend at 1830° C) was completely fused. The crucible was then allowed to cool and was examined. A few very small cracks had occurred where a hot spot unfortunately developed during the process of heating, but otherwise the crucible was in perfect condition. The heat had been so intense that the outside crucible was slightly fused.

"Several tons of magnesia have been electrically calcined and tested in a great variety of furnaces, and in every case excellent results have been obtained.

"There is one other important point to note in regard to this highly calcined material. The ordinary calcined magnesia absorbs carbon-dioxide gas, forming magnesium carbonate more or less rapidly, but this does not occur at all, or with extraordinary slowness, in the case of the electrically calcined product. An experiment demonstrated this very clearly. Two porcelain boats were filled with electrically calcined magnesia and a highly calcined magnesia of the ordinary kind, respectively. In both cases the samples were finely ground so that the particles were of approximately the same size. The boats were placed in a tube through which a rapid stream of moist carbon-dioxide gas was passed for 44 hours. At the end of that time the samples were weighed with the following results:

Sample	Percent increase in weight
Ordinary calcined .....	31.30
Electrically calcined .....	0.00

"In the preparation of this magnesia it is possible to use an arc furnace, but the method is not altogether satisfactory on account of its cost. It is unnecessary, and in fact disadvantageous in many ways, to fuse the magnesia. Accordingly, a resistance furnace has been worked out which will calcine the magnesia satisfactorily."

The book is an excellent one and the chemical public is indebted to the author for bringing together, in accessible form, the widely-scattered data. The author has, very properly, made no attempt to discuss the theory of refractories. Theory has to be made before it can be discussed. The reviewer desires to call attention to the extremely interesting field of scientific research which is offered by the problem of refractories.

Wilder D. Bancroft

*Inorganic Chemistry.* By Hamilton P. Cady. 15 X 21 cm; pp. 607. New York: McGraw-Hill Book Company, 1912.—The second book of the international chemical series treats of the general principles of inorganic chemistry from the standpoint of physical chemistry. Oxygen, hydrogen, water, hydrogen dioxide, chlorine, etc., are described, several of the fundamental concepts of physical chemistry being interspersed with the discussions. After the specific treatment of the non-metallic elements, the metals are treated, approximately according to the periodic system. Similarities and gradual changes in properties are pointed out, but very briefly, at the ends of the chapters on the metals. The periodic system is not used in treating the non-metals. No system of classification, however, is offered for these. The student is left to work out a system of coördination, otherwise he must depend on memory alone.

While agreeing with the author that elementary inorganic chemistry can be most easily taught from the standpoint of physical chemistry, the reviewer believes that here the limit has been overstepped. Too much physical chemistry has been introduced and the ordinary student is liable to become confused by learning of the phase rule, for instance, before he knows anything of the existence of heterogeneous reactions. It is believed that the mass law, reaction velocity, the phase rule, etc., as given here, have no place until the beginner becomes grounded, at least, with a fundamental knowledge of the physical and chemical properties of elements and compounds. It seems much simpler to take up processes, for instance, from the standpoint of the theorem of LeChatelier rather than from any other standpoint. The relegation of the atomic theory, and more especially the failure to emphasize the periodic system, is an unpardonable mistake.

The book is intended to be brief. The author, however, has undertaken enough to fill three volumes of the present size. One instance by way of explanation will suffice. Faraday's laws should not have been stated unless the mechanism of electrolytic conduction and electrolysis could be more fully treated. Numerous topics could appear more logically at different places than they are found. For instance, osmotic pressure is discussed long after lowering of the freezing point is treated. One might get the impression that osmotic pressure is caused by the lowering of the freezing point. There is no statement, in the general treatment of the gas laws, that these formulations do not hold over the complete range. It is only brought out under the separate treatment of the gases. It seems a pity that phenomena like passivity should not have been more thoroughly treated. Valence has not received the proper emphasis, and "positive" and "negative valence" are unfortunate terms. It is unfortunate, too, that such unqualified statements as the following have crept into this book. It is stated that platinum is "absolutely unchanged" after catalyzing the re-

action of hydrogen and oxygen. The melting point of chromium is given as about 1500° C. It is also stated that gold is obtained from the cyanide solution by deposition with the current on a lead cathode with an iron anode.

The book in spite of all this, however, is unique. It shows that it ought to be possible to write an elementary inorganic chemistry from a physical chemical standpoint. It is unfortunate, however, that the atomic hypothesis and the periodic system, two of the most important and productive generalizations, have not been given more attention.

C. W. Bennett

*Das Materialprüfungswesen.* By F. W. Hinrichsen. 17 × 25 cm; pp. xx + 607. Stuttgart: Ferdinand Enke, 1912. Price: 18 marks.—The author gives an account of the purpose, origin, and development of the Bureau of Testing Materials, and then brings together in this volume a number of the specific results obtained by the Bureau. He gives the official methods of testing: metals; ores; pigments; building material, including stone, bricks, tile, cement, mortar, and sand; paper; ink; textiles and dyes; fuels; water; fats and oils; rubber; leather; explosives.

This is quite a remarkable book. Of course the material is presented in a highly condensed form; but the presentation is clear and the book is invaluable for purposes of reference.

The bureau now receives about one hundred thousand dollars annually in fees and employs 227 people of whom 74 have had a college training. The receipts increase every year but the staff has remained constant for the last four or five years, so that the work is presumably getting heavier every year. It is interesting to note, that, even in Germany, the staff is not given adequate time for scientific research along the lines of the bureau, and that the routine testing is encroaching unduly. Of course the routine work is the justification for the existence of the bureau; but the routine work can never be done in the best possible way unless supplemented by coördinated scientific work.

Wilder D. Bancroft

*Elementary Applied Chemistry.* By Lewis B. Allyn. 13 × 19 cm; pp. xi + 127. New York: Ginn and Co., 1912.—An insight into the work of the analyst and chemical engineer is very clearly given in "Elementary Applied Chemistry." It deals with the analysis of many of the most common household articles in a way that will react not only on the pupil but on the community as well, and, while the methods are, of course, somewhat rough from a true analytical standpoint, each is carefully explained to enable the student to carry away an accurate idea of the object and importance of each experiment.

The author states in his prefatory note that "the main object of this work is to create and foster a real love and interest in the great science of chemistry—to cause the student to feel that he is a factor in the busy living world."

Unlike the usual text book, this little volume does not follow any order of chemical elements, but presents the work from the standpoint of processes, the more simple one of filtration first, followed by those requiring more skill of manipulation. Some of the more notable sections involve the simple yet successful methods for the examination of the compounds in soils, plants and textiles,

analysis of water, milk, ice cream, cheese and condensed milk; experiments with distillation, standard solutions and many other chemical methods. The knowledge gained from the sections on the examination of coal tar dyes, vegetable colors, preservatives, tooth powder, headache powders, oils, paints, and foods will be of special value to students in all lines of work. The spirit of the work is one of accurate, honest and truthful scientific thinking, a valuable asset for every student, regardless of its source.

Charles O. Brown

**Review Questions and Problems in Chemistry.** By M. S. H. Unger. 13 × 19 cm; pp. III + 101. New York: Ginn and Co., 1912. Price: \$0.50.—In this book Mr. M. S. H. Unger has presented a text rather broader than its field seems to warrant, in that a complete preparation along the full scope of this book is rather more than any college would require. The scheme carried out is very convenient and easy to use. Each section deals with problems and questions necessary for a complete review of some branch of chemistry as presented from the original text: definitions; laws and theory; the metals and elements, taken up by groups; and organic acids and compounds, with an appendix of chemical tables and constants. Many principles of physics that are closely allied to general chemistry are also included with problems. It is on the whole an excellent outline to follow in a preexamination review in connection with several standard works as references. Some of the best sections to enable one to clear up the confusion arising from the many physical and chemical facts, laws, theories and details of general chemistry are: Physical Laws and Theories, Chemical Laws and Theories; Equations and General Formulae; and a review of the elements by groups.

Charles O. Brown

**Introduction to Analytical Mechanics.** By Alexander Ziwet and Peter Field. 13 × 19 cm; pp. 373. New York: The Macmillan Company, 1912. Price, \$1.60.—“The present volume is intended as a brief introduction to mechanics for junior and senior students in colleges and universities. It is based to a large extent on Ziwet's ‘Theoretical Mechanics,’ but the applications to engineering are omitted, and the analytical method has been broadened.” This book does not touch very closely on the ordinary needs of the chemist. It will be of value chiefly to the student who is taking a good deal of engineering, and it really is not written for the present breed of chemists.

Wilder D. Bancroft

**A College Text-Book on Quantitative Analysis.** By Herbert R. Moody. 14 × 22 cm; 165 pp. New York: Macmillan Co., 1912. Price: \$1.25.—The book differs from most quantitative books in that the explanatory facts or “notes” on the analysis appear in large type on the same page as, and directly under the, directions for the procedure to which they relate. The idea is that the student will really read them during the course of the analysis and not after its completion. Another good feature of the book is that each experiment is preceded by a brief digest of the method, and by equations representing all the reactions involved. Practice is given in seven gravimetric, six volumetric and two electrolytic determinations. As the author says, the book will be especially useful to the student who is either taking up quantitative work by himself or in a class so large as to exclude much individual instruction.

G. E. F. Lundell



**Practical Measurements in Radio-activity.** By *W. Makower and H. Geiger*. 14 × 22 cm; pp. ix + 151. New York: Longmans, Green & Co., 1912. Price: \$1.60.—In the preface the authors say:

"Although researches into the nature of radioactivity have proved one of the most fruitful means of investigating atomic phenomena, a study of the methods employed for making radioactive measurements has not yet come to be regarded as an essential part of a course of practical physics or chemistry. This is no doubt to some extent due to a belief that a practical course must necessarily involve the use of large and costly amounts of radioactive material. This is, however, not the case, for it is possible to illustrate most of the principles of radioactivity by experiments made with simple apparatus using quite small quantities of radioactive material. To show how this can be done has been the main object of describing a number of experiments, many of which have been designed by Professor Rutherford as part of the course of practical work in the Honors School of Physics in the Manchester University and as an introductory course for students intending to undertake original investigations in radioactivity. It is hoped that this work may do something toward giving the subject a more prominent position in laboratory courses, and thus teach students the technique of one of the most fascinating branches of modern science.

"Although the book is primarily intended as a laboratory course in radioactivity, an attempt has been made to meet the requirements of those engaged in original investigations. On that account tables of radioactive constants and of the decay of different substances have been given; moreover, some portions of the subject have been dealt with in greater detail than would otherwise be necessary."

The subject is treated under the following headings: the quadrant electrometer and instruments used in connection with it; electroscopes; the ionization of gases; the alpha rays; the beta and gamma rays; the active deposits and radioactive recoil; radioactive transformations; standard measurements; the separation of radioactive substances; appendices.

The directions are clear and seem to be complete. A whole page, for instance, is given to a discussion, p. 25, of the best way to cut and mount gold leaves. The book should be very valuable to those wishing to undertake measurements in radioactivity on their own account.

The question has recently been raised, whether it would be desirable to publish a series of practical books dealing with physicochemical methods of investigation, particularly with the ways and means by which the actual measurements are made. The reviewer believes that this is desirable but that it is not feasible except in certain, special subjects. The present volume is somewhat more elementary than the volumes of the suggested series would be; but it is a step in that direction and the book is to be welcomed on that account as well as on its usefulness in the sphere for which it is intended primarily.

*Wilder D. Bancroft*



## CONCENTRATION CHANGES IN THE ELECTROLYSIS OF COPPER SULPHATE SOLUTIONS

BY C. W. BENNETT AND C. O. BROWN

It has been noticed<sup>1</sup> in the electrolysis of copper sulphate solutions with a rotating copper cathode, that the potential drop across the cell, with constant current, increases with an increase in the speed of rotation. In view of the fact that a more efficient stirring of the solution is obtained by increasing the rotation, concentration differences being thereby lessened, a drop in potential difference might be expected as a random prediction. Since this increase is rather large, and seemingly abnormal, it was deemed advisable to attempt an explanation of this phenomenon. As the object was a study of the voltage relations only, no attention was given the deposited copper except to note that it was pure, and that it completely covered the aluminum cathode upon which it was deposited.

A drawing of the cell is shown in Fig. 1, which may be described as follows: The revolving cathode C was made from a piece of aluminum pipe, 1" outside diameter, and 3" long. This was screwed to a brass shank which was mounted in a hollow steel spindle revolving in two bearings. The lower end of the cathode was closed with a rubber stopper. The current was led to the cathode through a wire, E, dipping into mercury placed in the hollow steel spindle. This cathode, mounted on an iron stand, well braced, dipped into a glass battery jar of about 1.5 liters capacity. This also held the anode D, of pure cast copper. The cathode was revolved by a shunt wound D. C. motor, G, operating on the 110-volt circuit, with varying speeds obtained by the starting box H. The current passing through the cell was taken from the same circuit, with a suitable resistance, J, and an ammeter, A, in series with the electrodes. It was at first planned to measure the back electromotive force of the cell by breaking the line

<sup>1</sup> Bennett: Jour. Phys. Chem., 16, 294 (1912); Trans. Am. Electrochem. Soc., 21, 253 (1912).



circuit and instantaneously connecting a very sensitive millivoltmeter across the cell. For this purpose, a switch was designed which consisted of two double pole switches, with the blades of one removed, the switches being mounted front to front with the end terminals a few hundredths of an inch wider apart than the width of the blade. This gave the effect of moving the end terminals of a double throw switch

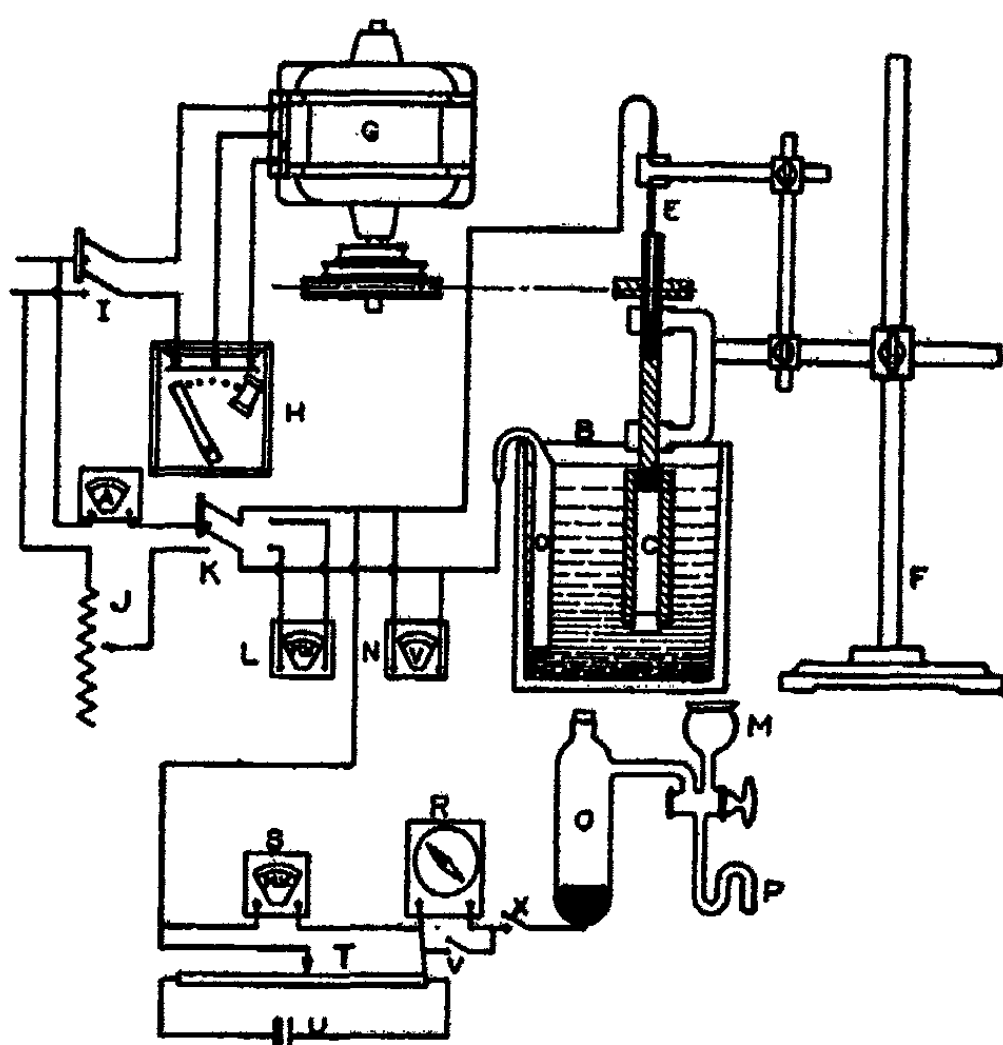

Fig. 1

very close together, so that the time for throwing the switch over was negligible. By covering this arrangement with transformer oil the connection being the same as an ordinary double throw switch, the line circuit could be broken even with 40 amperes flowing, and the cell connected with a delicate millivoltmeter, L, almost instantaneously. Voltage drop across the cell was measured with a voltmeter, N, which was

changed, whenever necessary, to ensure an appropriate scale or range for the required accuracy.

It was first thought advisable to check the measurement of the increase in voltage drop, mentioned above. For this measurement the solution was the same as that used in the previous investigation, consisting of a 12 percent solution of copper sulphate and 15 percent sulphuric acid. The current density as well as the speed of rotation of the cathode was varied. The results are given in Table 1.

TABLE 1—INCREASE IN POTENTIAL DIFFERENCE

Revolutions per minute	Current density		Amperes/sq. dm.	
	3.5	9.0	14.0	25.0
Difference of potential, volts				
1000	0.380	0.880	0.910	2.250
2000	0.390	0.890	0.919	2.300
3000	0.400	0.900	0.950	2.400
4000	0.410	0.910	0.965	2.400
5000	0.410	0.930	1.000	2.450

The increase with high currents is partly due to the fact that the resistance to the flow of a large current is affected relatively more than that with low currents, by the air which is drawn down into the solution, the latter occurring at high speed of rotation.

The most natural assumption to make in attempting an explanation of this phenomenon is, that it is due to an increase of resistance. This resistance may be a true one, or a virtual one, of the nature of a back electromotive force. Since the latter was the most easily handled, it was studied first. This order was chosen also on account of the fact, as will be seen below, that the results obtained here would show whether or not the real resistance factor was the important one.

In order to determine whether concentration differences were important, attempts were made to measure the back

electromotive force of the cell directly, using the double throw oil switch described above. A characteristic measurement may be given.

TABLE 2

Back electromotive force; C. D. 14 amps./sq. dm.	
Speed of rotation R. P. M.	Back E. M. F. Volt
1000	0.018
2000	0.020
3000	0.021
4000	0.022
5000	0.022

A slight difference was obtained, but not the difference sought for, which from Table 1 is seen to be 0.090 volt. It was decided that the time element in throwing the switch entered in here, so that concentration changes were equalized by the rapid stirring before the meter could be connected across the cell. This method of attack was therefore not pursued further.

If the voltage rise from 1000 to 5000 r. p. m., as shown in Table 1, be plotted against current, and the curve be extrapolated to zero current, an approximation of the real increase will be obtained, which eliminates the effect of resistance changes in the solution. This is shown by a curve in Fig. 2, obtained by plotting the values from Table 1. It may be seen that this curve extrapolates back to about 0.012 volt with zero current. This would indicate that there was a counter electromotive force in the cell itself without current flowing of the order of magnitude of 10 to 15 millivolts.

The next measurement to be made, therefore, was that of the voltage of the cell, copper | acidified  $\text{CuSO}_4$  solution | rotating copper electrode, at varying speeds of rotation of the electrode, to ascertain if there was a voltage which could act as a back electromotive force. For this a delicate millivoltmeter was used. The stationary electrode was cast copper, while

the copper on the revolving element was deposited there with a high current density and with rotation, which keeps the metal surface smooth, and is equivalent to working it cold. As has been shown<sup>1</sup> in the previous investigation, the crystals are small, while those of the cast anode are larger. Fine crystals have a larger solution pressure than large<sup>2</sup> ones, and consequently, the electrolytic solution pressure of fine-grained copper is higher than that of coarsely crystalline copper. As a consequence, therefore, since this occurs, an electromotive force must be set up through the solution from the electrolytic copper to the cast sheet. In other words, the

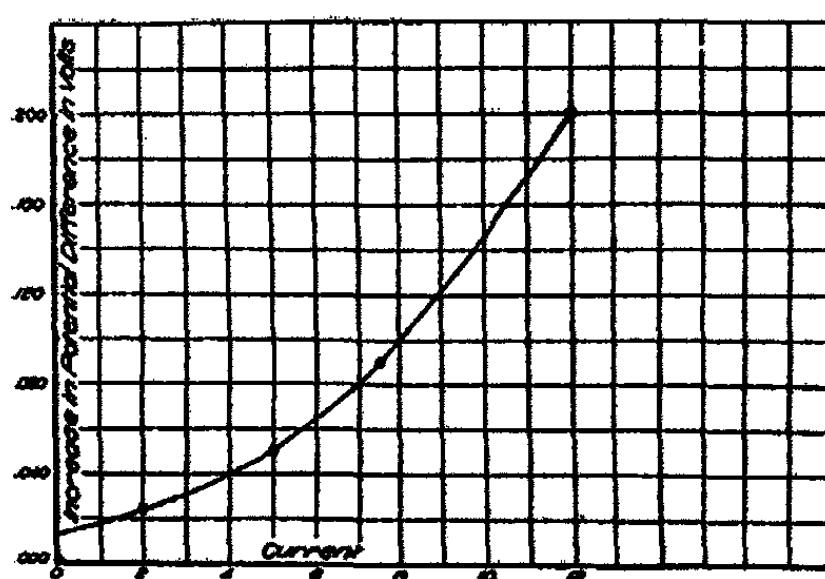

Fig. 2

electrolytic copper even when stationary should act as anode. This has been noted in the potential<sup>3</sup> of rough and polished metals. In the former case there are large crystals, while in the latter, practically the so-called amorphous material only is present. With zinc a difference of about 0.32 volt, and with copper, about 0.05 volt was obtained, the polished metal becoming more electropositive and therefore showing a greater solution pressure. Actual measurement of the case above showed that the prediction was valid. This, as well

<sup>1</sup> Loc. cit.

<sup>2</sup> Kenrick: *Jour. Phys. Chem.*, 16, 515 (1912).

<sup>3</sup> Erskine-Murray: *Phil. Mag.*, [5] 45, 403 (1898).

as the increase in voltage with increased rotation, is shown in Table 3. The solution was the same as the one used above.

TABLE 3—VOLTAGE INCREASE

Speed of rotation R. P. M.	Voltage of cell Volt
0	0.006
1000	0.009
2000	0.019
3000	0.010
4000	0.012
5600	0.014

From this it may be seen that there is an increase in the voltage of the cell with increased rotation of the anode (cathode when used as a secondary cell). In other words, this is equivalent to an increase in the back electromotive force. These measurements show that the increase in resistance is not the important factor in determining the increase in voltage drop with rotation, when current is flowing. If it were all-important, the voltage against the auxiliary electrode should decrease, for the internal resistance would increase. Practically no loss due to the brush contact could be measured, so this was not considered further.

It has been shown that the effect of increased rotation is to increase the voltage of the above-named cell. The resistance of the cell may be increased, it being necessary to postulate that the voltage increases relatively faster than the resistance, giving the final effect of a rise in voltage.

In order to eliminate the effect of resistance and determine the true increase of potential due to rotation, the voltage of the rotating cathode was measured against a standard mercury electrode, using the compensation method. The electrode and bridge used are shown in Fig. 1. The electrode consisted of mercury, mercurous sulphate | 2 N sulphuric acid. The following was obtained with the rotating electrode, 12 percent copper sulphate and 15 percent sulphuric acid solution being used.

TABLE 4—TRUE INCREASE OF POTENTIAL OF ROTATING ELECTRODE

Speed of rotation R. P. M.	Voltage Volt
0	0.386
1000	0.390
2000	0.393
3000	0.395
4000	0.397
5000	0.400

The increase is of the same order of magnitude as that measured by the millivoltmeter, as given in Table 3, and also of the same magnitude as the rise in voltage given by the curve in Fig. 2, with zero current. It may be said, therefore, that the increase in voltage is sufficient to explain the facts as obtained from the extrapolation of the curve in Fig. 2. The increase in the effect of rotation with increased current flowing will be discussed later. No change in the potential of the stationary electrode with increasing rotation of the other could be measured.

Having seen that the effect is caused by the increased potential of the rotating element, creating a back electromotive force, the question as to the cause of this increased potential demands attention. The increase in voltage is necessarily due to an increased solubility of the copper from the rotating element, as the rotation increases. The increased solubility of the copper in the acid present, by the introduction of air or by the removal of the copper ions from the sphere of action, by more efficient stirring, thus making room for more, and thereby increasing the rate of solution, was shown to be incapable of explaining any rise. For this a 15 percent solution of sulphuric acid with no copper sulphate was used. The voltage was measured against the standard electrode by compensation, but practically no change with rotation was obtained. Using this as a secondary cell, and measuring the drop of potential at the revolving element (cathode) by compensation, no increase in potential difference

1. The first part of the document discusses the importance of maintaining accurate records of all transactions and activities. It emphasizes that proper record-keeping is essential for transparency and accountability, particularly in financial matters. The text notes that without clear records, it becomes difficult to track expenses, revenues, and other critical data points.

2. The second section focuses on the role of technology in modern record-keeping. It highlights how digital tools and software solutions can significantly reduce the risk of human error and improve the efficiency of data management. The document suggests that organizations should invest in reliable technology to ensure their records are secure, accessible, and up-to-date.

3. The third part of the document addresses the legal and regulatory requirements surrounding record-keeping. It outlines the various laws and standards that govern how data should be stored, protected, and shared. The text stresses that compliance with these regulations is not only a legal obligation but also a key factor in building trust with stakeholders.

4. The fourth section discusses the importance of data security and privacy. It explains that as the volume of data grows, the risk of breaches and unauthorized access also increases. The document provides guidance on implementing robust security measures, such as encryption, access controls, and regular security audits, to protect sensitive information.

5. The fifth part of the document explores the benefits of data analysis and reporting. It shows how analyzing recorded data can provide valuable insights into organizational performance, trends, and areas for improvement. The text encourages organizations to leverage their records to make data-driven decisions and optimize their operations.

6. The final section of the document offers practical advice and best practices for implementing an effective record-keeping system. It covers topics such as defining clear policies, training staff, and regularly reviewing and updating the system. The document concludes by reiterating the importance of consistent and accurate record-keeping for long-term success.



[The page contains extremely faint and illegible text, likely due to low contrast or scanning quality. The text is organized into several paragraphs, but the individual words and sentences cannot be discerned.]

with increased rotation, shown by the slope of the curves, increases with increased acid concentration.

The 12 percent solution was run at 50° C, the increase in single potential being about one millivolt greater than at room temperature. This difference is not large but is in the proper

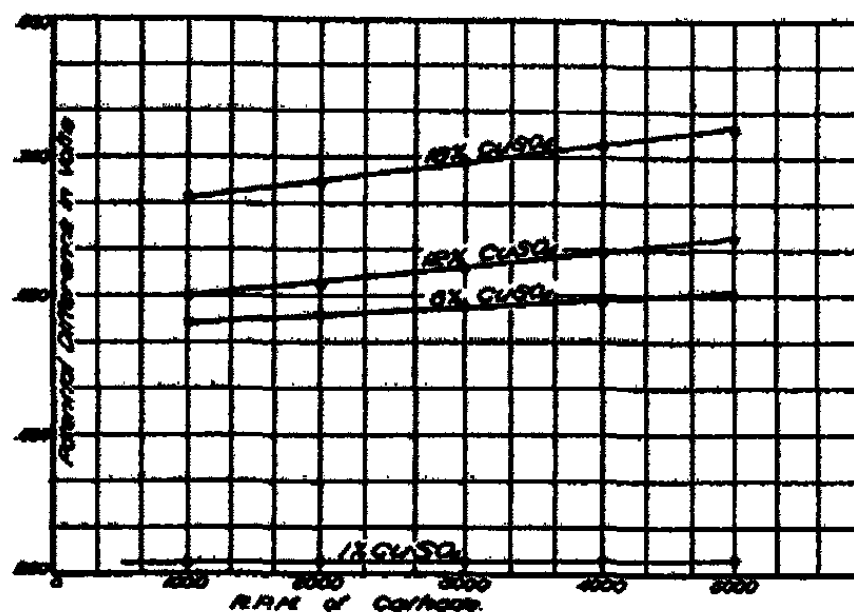

Fig. 4

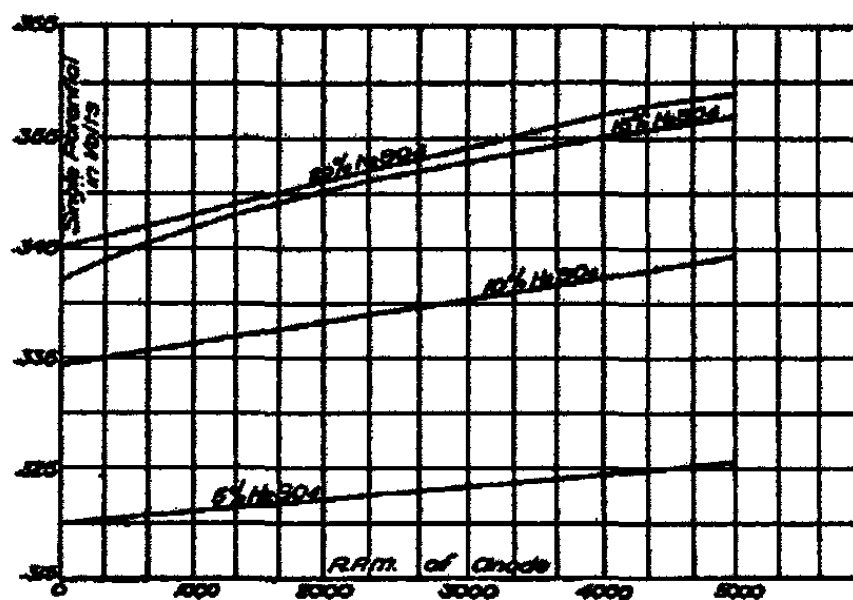

Fig. 5

direction, since a high temperature increases the concentration of cuprous ions in equilibrium with cupric ions.

In the copper coulometer, it is well known that alcohol decreases the concentration of cuprous ions at equilibrium. The voltage difference, therefore, with increased rotation,

should be less when alcohol is present, than when absent. With 15 percent alcohol in the solution the voltage rise is slight, as is shown in Fig. 6, being 0.003 volt as compared with 0.010 for the solution without alcohol.

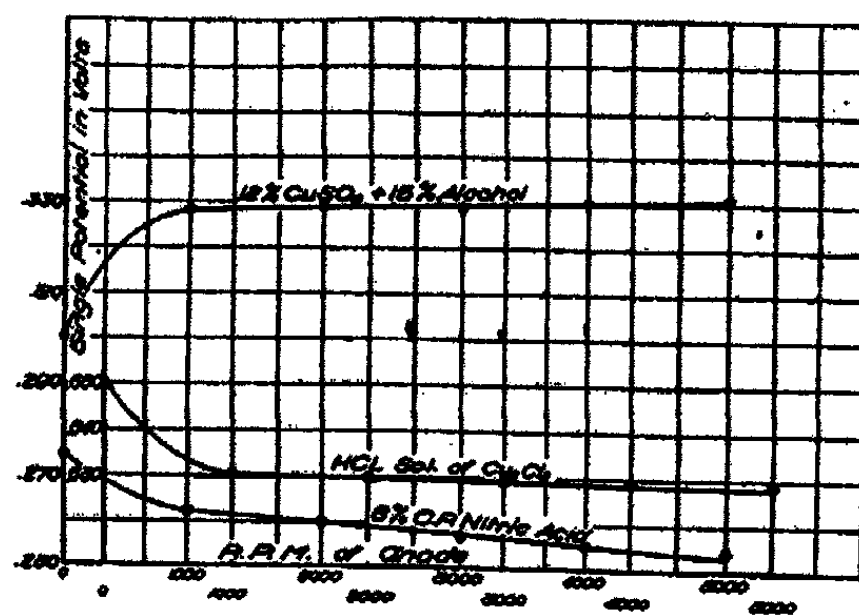

Fig. 6

As a final check on the theory, the potential of the rotating element was measured in a hydrochloric acid solution of cuprous chloride. This is also shown in Fig. 6. The potential decreases markedly from stationary to 1000 revolutions per minute and then very slightly as the rotation is increased. The explanation is simple. There are a small number of cupric ions at the electrode, in equilibrium with the cuprous ions and metallic copper. By rotating the electrode these cupric ions are removed, being replaced by undissociated cuprous salt which may dissociate to maintain the concentration of cuprous ions. The voltage, therefore, decreases, with rotation, by an amount depending on the efficiency of removal of cupric ions from the electrode.

It has been shown recently by work<sup>1</sup> on the quantitative separation of copper, that the corrosion of a stationary piece of copper in nitric acid solution was many times that of a rotating piece. This is explained by considering that the rotation prevents the accumulation of nitrous acid at the

<sup>1</sup> Stansbie: Proc. of the Faraday Soc., November 26 (1912).

surface of the copper, by reduction of the nitric acid, since it is thrown off practically as fast as formed. The nitrous acid, the active agent in dissolving copper, not being allowed to act, the metal is corroded only slowly as compared with the stationary sheet where this reagent may accumulate.

Since the solubility is decreased by rotation, the electromotive force or the potential of the metal should decrease with rotation in nitric acid solution. This was checked experimentally and found to be true. The curve is shown in Fig. 6.

It has been seen (Table 1 and Fig. 4) that the drop across the cell, with current flowing, is greater than 10 to 15 millivolts, or the value accounted for, by the increased voltage of the cell in the direction opposite to the flow of the current. A part of this is unquestionably due to an increase in resistance by air bubbles as was stated above. Aside from this, however, the back electromotive force of the rotating electrode may be higher than the electrode potential measured. The current will deposit cuprous ions more easily than accomplish the reduction of cupric to cuprous ions. The concentration of cuprous ions, during this electrolysis, therefore, may be considered practically negligible. Since their concentration is zero, the voltage, or back electromotive force, will be greater than when appreciable amounts of these ions are present, as must be the case when single potentials are measured.

From this work, it may be concluded that:

1. There is a definite, measurable increase in potential difference in the electrolysis of acid copper sulphate solution, as the speed of rotation of the cathode is increased from 1000 to 5000 r. p. m., for instance.
2. From Fig. 2, the increase indicated to maintain zero current is about 0.010 or 0.015 volt.
3. This can be accounted for by the increase in the rotating electrode potential, with increased rate of rotation.
4. The increase in the potential of the rotating electrode with increased rotation is due to the tendency to form cuprous

ions, the increase being greater when conditions are favorable for the formation of cuprous ions, and *vice versa*. As the rotation increases, the stirring becomes more efficient, the cuprous ions are removed, and the solubility of the copper is therefore increased. This gives rise to a higher voltage.

5. The potential of the rotating electrode (cathode when current is flowing), may be much higher than that measured here without current, probably due to the removal of cuprous ions from the solution by precipitation.

6. The increase in the drop of potential with increasing rate of rotation of the cathode in the copper-copper sulphate electrolysis is probably due, in part, to an increased resistance.

7. The decrease in the potential of the electrode in cuprous chloride solution is due to the more rapid removal of the cupric ions with stirring, thus removing the reagent dissolving the copper.

8. The potential of a rotating electrode in nitric acid goes down with increasing rate of rotation, due to throwing off more and more thoroughly the film of nitrous acid, thus decreasing the solution of the copper, and therefore, its voltage.

9. The solution pressure of a metal is increased, if the size of its crystals be decreased. This is made apparent by an increase in the potential of the metal as the crystal size is decreased, by hammering or burnishing, for instance. It is also shown by the fact that fine-grained metal (electrolytic copper) is electropositive to more coarsely crystalline metal (cast copper).

*Electrochemical Laboratory  
Cornell University*

## ON THE MOLECULAR CONSTITUTION OF THE FREE SURFACES OF LIQUIDS

BY M. M. GARVER

In a former paper on the polymerization of liquids I discussed the equation

$$\frac{\gamma}{2z} = \rho \frac{R}{m} T \dots\dots\dots (A)$$

and the interpretation there given led to the hypothesis that the attractive forces between molecules, like the pressures exerted by molecules, were independent of the mass of the molecule.<sup>1</sup>

While this hypothesis did not seem very probable, it yet appeared necessary to assume such molecular forces in order to interpret the above equation. However, further study of the subject has suggested an alternative hypothesis that seems more probable. In a later supplementary note<sup>2</sup> attention was called to the fact that both  $\rho$  and  $m$  are required to represent experimentally determined values. Hence the ratio  $\rho/m$  is not only constant for a given temperature but both the terms  $\rho$  and  $m$  are also constant. Therefore, the supposition that the ratio, only, was constant while the terms varied proportionally, is inadmissible, or not in accordance with the experimental facts. Since the equation (A) above, is shown to be applicable to every liquid, whether polymerized or not, it follows that unless the superficial film is constituted differently from the interior of the liquid, that all liquids are equally polymerized or are equally unpolymerized. Now there is indisputable evidence which proves that all liquids are not equally polymerized. The characteristic of equality of condition indicated by equation (A) can apply, then, only to the surface portions. If we suppose that the surface

<sup>1</sup> Jour. Phys. Chem., 16, 454 (1912).

<sup>2</sup> Ibid., 16, 679 (1912).

of a liquid in equilibrium with its saturated vapor has the same molecular constitution as the vapor immediately in contact with it and that the attractive forces per molecule are numerically equal to the pressure the same molecule would exert if there were no attractive forces, then equation (A) would be completely satisfied, for such supposition would be in complete accord with the experimental requirement that the molecular weight used must be determined from the density of the saturated vapor. The value of  $m$  as thus determined may or may not agree with the generally accepted value as determined from the density of the unsaturated vapor, but will depend upon whether the vapor is already polymerized or not. For instance, the molecular weight of saturated acetic acid vapor at the boiling point of the liquid averages 96 or 97 instead of 60 as obtained from the density of the unsaturated vapor at higher temperatures.

The only difficulty that requires a departure from current conceptions regarding the nature of liquids lies in the fact that the average density  $\rho$  of the liquid, which may be more or less polymerized, is the same as the density of the unpolymerized film on the surface, which, from equation (A) above, should have the same molecular constitution as the vapor immediately in contact with it. This difficulty, however, does not seem insuperable. If we regard the interior of a liquid at a distance greater than  $\epsilon$ , the range of molecular action, from the surface as possessing the same molecular potential everywhere within the interior, the polymerization in the interior merely implies that the average molecular volume is independent of polymerization, the density being determined solely by the molecular forces acting between individual molecules in the bounding surface. We should have to assume that it is these forces at the bounding surfaces that determine the density and consequent volume of the liquid and that in the interior of a liquid the average force due to the liquid acting on each molecule in any given direction is zero, but that in consequence of the relatively crowded condition as compared with the gaseous phase, complexes are formed so as to act *temporarily* as single

molecules in so far as their average energy of translation is concerned. Such a view would account for all the peculiarities which we attribute to polymerization. It would also explain why, as a general rule, polymerization decreases with increased temperature, or as the average energy of translation increases. This view, also, would enable us to account for the experimentally observed fact that as the temperature rises, the pressure of the saturated vapor of polymerized substances, such as the alcohols, increases more rapidly than is observed with less polymerized liquids. For, as the temperature rises and polymerization diminishes, not only do the surface forces diminish but the ability of the interior liquid to supply unpolymerized molecules to the vapor necessitates a greater density of the vapor, or a larger number of molecules per unit area, to equilibrate this increased ability to supply vapor molecules.

The matter may be easily understood if we abandon the idea of all hypothetical interior molecular pressure in liquids other than is indicated by the equation (A) which represents the rate of change of momentum normal to one side of a given element of area. If we regard the interior of a liquid drop, for instance, as *subjected to no forces* except the superficial ones which determine the density, and to the forces between molecules which have slight influence beyond the range of molecular action and which merely determine the average curvature in the path of the molecules, then the constancy of the *average* molecular volume can be seen to be independent of polymerization and to depend solely upon the attractive forces of unpolymerized molecules lying in the bounding surface between the vapor and liquid phases. The bounding surface with its attractive forces simply replaces the confining walls that would be necessary if the substance were a perfect gas of the same temperature, density, and molecular weight as the saturated vapor. In terms of stress and strain, *since the molecules and complexes are assumed to be free and executing independent motions*, the only *strain* that can result from a normal *stress* must be represented by the density. So



far as "pressure" and strains are concerned, the interior of an ideal or "perfect" liquid, must resemble exactly the interior of an ideal or "perfect gas" except that the molecular paths are in general *curves* instead of straight lines terminated by "collisions."

*State College, Pa.*  
*Feb. 12, 1913*

U. S. GOVERNMENT PRINTING OFFICE: 1913

## COLLOIDAL SUSPENSION OF GRAPHITE

BY HENRY L. DOYLE

Experiments were made at first to determine whether substances, which are adsorbed by carbon and graphite, have a marked peptonizing action on them. Boneblack and Acheson graphite were used and were ground in an agate mortar. In the earlier experiments they were ground dry, but later they were ground wet, being ground for one hour in the solutions in which they were to be suspended.

Since Spring<sup>1</sup> had found that soap solutions would wash rouge or boneblack through filter paper, this seemed to offer a promising line of attack. Finely ground boneblack was placed on a filter and washed with distilled water until the wash water ran through colorless. The residue on the filter was then washed with a 5 percent sodium oleate solution. Carbon was carried through the filter. A similar experiment was then made with graphite and a similar result obtained. Negative results were obtained with boneblack, using 0.5 percent and 5.0 percent solutions of sodium chloride, cupric nitrate, caustic soda, acetic acid, hydrochloric acid, and gelatine.<sup>2</sup> Negative results were obtained with saturated and half-saturated solutions of mercuric chloride; and also with chlorine water. The 5 percent sodium oleate solution not only carried the carbon through the filter but held it pretty well in suspension over night. In fact, the carbon had not all settled at the end of two days.

All of these substances are adsorbed readily by some forms of carbon and yet only one of them, soap, carried the boneblack through the filter paper. Since there was a possibility of a disturbing effect due to the filter paper, it was decided to change to suspensions in stand-glasses and to note the relative rates of settling.

A considerable amount of boneblack was ground up and

<sup>1</sup> Zeit. Kolloidchemie, 4, 161 (1909); 6, 11, 109, 164 (1910).

<sup>2</sup> Ammonia was added to the 5 percent gelatine.

the same amount, so nearly as possible, was taken for each experiment. The experiments were made in stand-glasses holding about 500 cc. Since there might be an optimum concentration, experiments were made with 0.5, 1.0 and 5.0 percent solutions of sodium chloride, acetic acid, chlorine water, caustic soda, hydrochloric acid, cupric nitrate, gelatine, sugar, and soap. Only with the last three substances was there any noticeable suspension. The most dilute soap solution kept up a little boneblack, the 1 percent solution more, while the 5 percent solution was quite efficient. The most concentrated sugar solution did fairly well; but the results were negative with the 0.5 percent solution. Only the most concentrated gelatine solution had any protecting action and that one not much. The 5 percent gelatine could not be kept fluid enough at ordinary temperatures. Consequently, the experiment was made at about 50° in a water bath, using a 100 cc stand-glass. The largest particles are formed in the acetic acid, hydrochloric acid, and chlorine solutions, while fairly large particles are formed in the cupric nitrate solutions. With hydrochloric acid there was a visible evolution of gas, presumably from calcium carbonate in the boneblack.

Since sodium oleate and gelatine both keep up the carbon, and since both lower the surface tension of water, it seemed worth while to consider whether solutions of the two having the same surface tension have approximately the same effect in keeping boneblack in suspension. The weight per drop from a given orifice was found to be 0.042 gram for water, 0.038 gram for a 2 percent gelatine solution, and 0.016 gram for a 2 percent sodium oleate solution. Since the lowering of the surface tension of water is much greater for a given weight of soap than for an equal weight of gelatine, it was necessary to keep down to a low soap concentration. It was hoped that a gelatine solution might be made having as low a surface tension as a 1 percent sodium oleate solution. This proved to be impossible, since a 10 percent gelatine solution gives a much higher drop weight at 60° than a 1 percent soap solution at ordinary temperatures. An attempt was made to

keep the gelatine solution fluid at lower temperatures and a solution was therefore made up containing 10 percent gelatine and 5 percent ammonium sulphocyanate. This was so viscous at ordinary temperatures that experiments with it seemed useless.

It seemed desirable to try some experiments with a dissolved substance which was not an electrolyte and which was readily adsorbed by carbon. Iodine was apparently the most satisfactory substance for this purpose; but its sparing solubility in water made another solvent necessary. Benzene was the first one tried. Benzene solutions were made up containing 1-5 percent iodine. Boneblack was ground with some of the benzene solution in an agate mortar for an hour and was then poured into the rest of the benzene solution in a 100 cc glass cylinder. The time was determined for the boneblack to settle practically completely. Check experiments were run with benzene, containing no iodine. No difference could be detected due to the iodine. The experiments were repeated, allowing the mixtures to stand for a definite time, and then filtering. The residues were washed with benzene until all traces of iodine were removed. The two sets of residues on the filters were identical so far as the eye could tell.

A corresponding set of runs was also made with graphite instead of boneblack. The same results were obtained. Since graphite did not stay up well in benzene and since it did not grind easily in this liquid, a change was made to absolute alcohol.

At the end of a given time the bulk of the liquid in a cylinder was decanted and enough caustic potash solution added to decolorize the iodine. Of course the same amount was added in the check test where the alcohol contained no iodine. With boneblack, one run gave more carbon suspended in the iodine solution, one the same amount, and one less. The experimental error seems to be rather large; but there is no proof of any increased suspension due to the iodine. Negative results were also obtained with graphite.

Since the adsorbing power of boneblack varies very much with the previous history of the sample<sup>1</sup> and since it was not certain whether the graphite adsorbed any appreciable amount of iodine, some experiments were made in regard to this. Saturated solutions of iodine in water were made up and then filtered so as to remove all particles of undissolved iodine. The filtered solutions were placed in 500 cc glass-stoppered bottles. One was shaken with boneblack and the other with Acheson graphite. After settling, the bottle containing the boneblack was much less colored than the one containing graphite. After several shakings, the liquid was completely decolorized in the bottle containing boneblack while the liquid in contact with graphite was changed but slightly. This seemed to show that iodine was only slightly adsorbed by graphite and that the adsorption by boneblack was very much greater. The bottles were put away for two weeks however and at the end of that time the liquid in contact with graphite was also decolorized. This looked as if the difference were more a matter of rate of adsorption than of total adsorption.

Since the rate of adsorption of iodine by graphite is evidently low, it seemed wise to repeat the experiments on suspension by shaking a solution of iodine in alcohol for a long time with graphite, making a parallel run with a similar bottle containing graphite and alcohol only. To one bottle was added 60 cc absolute alcohol, 1 gram graphite and 6 grams iodine, while the other bottle contained 60 cc absolute alcohol and 1 gram graphite but no iodine. The two bottles were shaken for several days a few hours a day and then allowed to stand. Equal portions of the liquids were decanted into glass cylinders and equal quantities of a dilute caustic potash solution added to each. The amount added was sufficient to decolorize the iodine solution. Owing to the alcohol iodoform was formed. Each solution was filtered through a tared filter and the iodoform was dissolved with ether. The ether

<sup>1</sup> Pelet-Jolivet: *Die Theorie des Färbeprozesses*, 58 (1911).

apparently extracted some iodine from the graphite as well. The filters were dried and weighed. There was slightly more graphite from the bottle containing iodine than from the other. So far as this one set of experiments shows anything, the iodine does keep the graphite up a little. The experiment was not repeated because the real conclusion to be drawn from it seemed to be that iodine keeps graphite in suspension very slightly, if at all.

Since boneblack varies very much in composition, a sample was ignited. It gave 83.5 percent of ash, presumably calcium phosphate. It is quite possible that different results would have been obtained with a boneblack from which the calcium phosphate had been removed; but it seemed wiser at first to work with material similar to that used in most experiments on adsorption. Incidentally an ash determination was made on a sample of natural graphite marked C. P. It showed 43 percent of ash. This material was not used in any of the experiments.

It was now decided to try the effect of protecting colloids. As a preliminary, a sample of aquadag was analyzed. The paste was dried on an air bath at about 100°-125°. When nearly dry, the hard cake was ground in an agate mortar, dried and ground again. In a gram sample, determinations were made of volatile matter 9 percent, and ash 8 percent. The ash was dissolved in sulphuric acid, filtered and precipitated with ammonia. The ferric oxide was dried and weighed. The copper was determined electrolytically. The dried sample of aquadag contained 3.2 percent  $\text{Fe}_2\text{O}_3$  and 1.2 percent Cu.

It did not seem probable that aquadag would contain so much iron unless this were beneficial in some way. To test this, a fairly dilute solution of ferric acetate was boiled for a few minutes so as to hydrolyze it. One gram of finely ground graphite was added to 60 cc of this solution and 1 gram to 60 cc water. The mixtures were placed in 100 cc bottles and were shaken for an hour and a half with a power shaker. The bottles were allowed to stand for 2 hours when equal amounts of the supernatant liquid were poured off, sulphuric

acid being added to dissolve the colloidal ferric oxide. There was more graphite suspended in the liquid from the bottle containing iron. To the residues in the bottles, water was added, and the bottles shaken as before. As before, more graphite was in suspension in the liquid from the bottle to which iron had been added. Water was added again to the residues with the same result. When these last solutions were filtered, a distinct difference could be seen in the character of the graphite. In the one containing iron, the particles were fine and covered the entire surface of the filter, whereas the particles from the water were agglomerated and formed little heaps. These experiments show that a hydrolyzed ferric acetate solution keeps finely-divided graphite in suspension to a certain extent. It would have been rather gratifying to have tried these experiments and the later ones with the same graphite which is used in making aquadag and oildag; but the Acheson company refused to sell any.

Experiments were now made with mixtures of iron salts with organic substances, beginning with gelatine. Half a gram of graphite powder, half a gram of gelatine and about 0.1 gram ferric chloride were placed in a bottle together with 60 cc water and a lot of glass beads. Another bottle was equipped in the same way except that the ferric chloride was omitted. Both bottles were shaken for 4 hours in a power shaker. On standing, no difference could be detected between the bottles. The contents of the bottles were then diluted to 500 cc and allowed to stand. If anything, the suspension was less satisfactory in the bottle containing the ferric chloride. Similar experiments using less ferric chloride, were no more satisfactory. Substituting 0.5 gram tannic acid for the gelatine and shaking for 10 hours, did not improve matters, nor did cutting down the tannic acid to 0.1 gram.

The experiment with tannic acid was repeated, adding ammonia until it could be detected by the smell. The bottle was shaken and opened from time to time to find out whether the solution was still ammoniacal. If not, more ammonia was added. The result was apparently a beautiful black

suspension which remained black. Unfortunately, most of this was due to the formation of an iron ink, which ought to have been foreseen. Similar experiments with catechu gave no satisfactory results. It seemed possible that the method was faulty, so experiments were made to find out a good method for getting catechu into suspension. In one case the catechu was ground and heated with water, after which ammonia was added; in the other case the ammonia was added to the catechu before the heating took place. The second method gave better suspensions of catechu. Qualitative experiments were then made as to the action of an ammoniacal suspension of catechu on graphite. To one of the bottles fine iron filings were added. Both bottles were shaken in the power shaker; the solutions were diluted and stirred by bubbling air through them. After standing over night, equal amounts were taken from each cylinder and precipitated with concentrated hydrochloric acid. The precipitates were separated by filtration. There was a larger residue from the bottle containing iron. The experiment was repeated several times, always with the same result.

A few quantitative runs were made using a suspension containing 25 cc water, 0.5 catechu and 10 cc ammonia as deflocculating agent. In the first run 5 grams graphite and 0.5 gram Fe (5 grams graphite and no iron in the check experiment) were ground for 2 hours in a McKenna grinder with 10 cc of the deflocculating agent, a little water being added when necessary to keep the mass of the right consistency. The ground mass was diluted to 1000 cc and 100 cc samples pipetted off after standing. After precipitation with concentrated hydrochloric acid, the precipitates were collected on tared filters and weighed. In some cases still greater dilutions were taken. The following results were obtained:

	No iron Gram	With iron Gram
Weight of precipitate	0.0350	0.0812
Weight of precipitate	0.0110	0.0275
Weight of precipitate	0.0092	0.0188



The presence of iron causes at least twice as much graphite to be kept in suspension by an ammoniacal catechu suspension as would be the case without iron. The character of the suspension is better as shown by filter-paper tests. The character of a deposit can be judged by the edge of the circle where the drop is placed. There should be no saw-tooth effect; the color should go through the paper and also extend out as far as the water does, or nearly as far.

No experiments have been made with copper salts; but it is interesting to note that Pickering<sup>1</sup> obtained good emulsions of kerosene in water with basic ferric sulphate or cupric sulphate as emulsifying agent.

At the suggestion of Mr. Briggs I tried a solution of caseine in sodium phosphate as a means of keeping graphite in suspension. A very good suspension was obtained which seemed to stay up indefinitely and which was not very sensitive to acids.

Experiments were next made to determine, if possible, under what conditions graphite could be suspended in machine oil. Catechu could not be used because it did not dissolve in machine oil and seemed to undergo a decomposition when heated in oil. When ground with graphite and oil, catechu gave no suspensions, or rather the suspensions settled at once. It was, therefore, necessary to find some other colloid, and it seemed as though the best thing would be a gum or resin which would dissolve in hot oil.

The first substance to be tried was resin; but no satisfactory results were obtained with this. Melted resin was added to hot or boiling oil; but the graphite did not stay in suspension unless the mixture was very thick. The procedure was to heat about 1 gram of resin until it was volatilizing rapidly, to add 75 cc hot oil, and then to boil. Of the resulting mixture, amounts varying from one drop to 5 cc were added to enough oil to make 15 cc and the whole ground with 2 grams of graphite for 30 minutes in a McKenna grinder.

---

<sup>1</sup> Jour. Chem. Soc., 91, 2001 (1907).

In no case would a dilute solution of resin keep the graphite in suspension.

Shellac did not dissolve in the oil and asphaltum did not keep the graphite up until the concentration was high enough to make the mass sticky.

It next occurred to me that perhaps ferric oxide might work well. Graphite was therefore ground first with moist precipitated ferric hydroxide and afterwards with oil. A suspension of graphite was obtained in this way, but it was not very satisfactory. I varied the relative amounts of ferric hydroxide and water from an almost dry paste to a liquid, and the absolute amounts from a drop to a cubic centimeter. The best suspension was obtained with small amounts both of water and of ferric hydroxide. The method seems to have possibilities if the grinding with the oil could be carried on at a temperature at which the water would evaporate until the protecting action of the ferric hydroxide was a maximum.

Since soap had proved serviceable when making suspensions of graphite in water, it seems worth while to try something similar for suspensions in oil. In view of the fact that paint-makers find that the addition of a little water enables them to keep the paint up better in the oil, the addition of water was also to be considered. In the first runs sodium oleate was used, the soap and water being ground with the graphite for 10 minutes. The oil was then added, a little at a time, the grinding being kept up for 20 minutes longer. The following results were obtained with 2 grams graphite, 0.1 gram sodium oleate, 15 cc oil, and varying amounts of water.

Water	Suspension
1.0 cc	Stiff emulsion cracking soon
0.5 cc	Stiff emulsion cracking soon
0.3 cc	Stayed up somewhat longer
0.2 cc	Stayed up thirty minutes
0.1 cc	Fair suspension
2 drops	Fair suspension
1 drop	Good suspension for 12 hours
0	Not so good as preceding

Magnesium soap was tried next and was made by heating sodium oleate with a magnesium sulphate solution, the magnesium oleate separating. As in the case of the sodium oleate, the best results were obtained with only one drop of water. The suspension with magnesium oleate seemed to be better than the one with sodium oleate.

Since iron oxide proved beneficial in keeping graphite suspended in water, it seemed probable that an iron soap might be an excellent substance with which to make a suspension of graphite in oil. I first tried heating ferric acetate with sodium oleate. I got a small amount of a substance which I thought might be an iron soap; but it was not a success as a protecting colloid. I next tried to prepare an iron soap by heating linseed oil with ferric oxide. After several attempts in which I did not get anything much like a soap, I finally got a viscous liquid which may have been a soap; but which contained a lot of decomposition products and which did not work well with oil and graphite. I went back to the first method; but substituted ferric chloride for the acetate. On heating ferric chloride solution with sodium oleate, I obtained a gummy mass which was insoluble in water and which separated readily. With this gummy material a series of experiments was made precisely similar to those with sodium oleate and magnesium oleate. So long as any water was added, I found it impossible to get any satisfactory results, because the soap remained in viscous particles and settled rapidly.

On the other hand, graphite with this iron soap and oil but no water gave better suspensions than I have been able to get in any other way. The amount of soap could vary between 0.1 gram and 1.0 gram per 20 cc and still give good suspensions. In one case, only  $\frac{1}{8}$  inch of oil could be seen above the suspension after standing for two weeks.

While working with the iron soap, I also tried heating paraffin for about 100 hours. A dark, gummy residue was obtained which gave fairly good suspensions when ground

with graphite and oil. The results were not as satisfactory as those obtained with the iron soap.

The general results of this paper are:

1. Experiments have been made on the suspension in water of boneblack having 83.5 percent ash, and on the suspension in water and in oil of finely-ground Acheson graphite.

2. Sodium oleate will hold boneblack or graphite in aqueous suspension; concentrated solutions of sugar or gelatine have a slight effect.

3. Although sodium chloride, cupric nitrate, caustic soda, chlorine, acetic acid, and hydrochloric acid are adsorbed readily by boneblack, no one of these substances had any appreciable effect in keeping boneblack or graphite suspended in water.

4. Iodine was tried with boneblack and with graphite in benzene and in absolute alcohol; but there was no proof that it was beneficial.

5. The boneblack decolorized a saturated solution of iodine in water fairly quickly; the graphite decolorized the solution also, but very slowly.

6. A sample of dried aquadag was found to contain 3.2 percent  $\text{Fe}_2\text{O}_3$  and 1.2 percent Cu, which formed part of the 8 percent ash.

7. A hydrolyzed ferric acetate solution kept boneblack and graphite in suspension in water.

8. Adding ferric chloride to gelatine, tannic acid, or catechu solutions did not have any beneficial effect.

9. Better suspensions of catechu are obtained by adding ammonia before heating instead of after heating.

10. When graphite was ground with ammoniacal catechu suspension and the mixture then shaken with iron filings and air, much more graphite was held in suspension than by catechu alone.

11. A good suspension of graphite in water can be obtained by using a solution of caseine in sodium phosphate.

12. No satisfactory suspension of graphite in oil could be obtained by means of resin or shellac.

13. A fair suspension of graphite in oil can be obtained by means of ferric hydroxide and water, using very little of both.

14. Good suspensions of graphite in oil can be obtained by means of sodium oleate or magnesium oleate and a trace of water. A good proportion is 15 cc oil, 0.1 gram sodium or magnesium oleate, and one drop of water.

15. An iron soap was prepared by heating ferric chloride solution with sodium oleate. Excellent suspensions of graphite in oil were obtained by means of this iron soap. No water should be added.

16. A fair suspension of graphite in oil was obtained by means of a gummy product prepared by heating paraffin in the air.

This investigation was suggested by Professor Bancroft and has been carried on under his supervision.

*Cornell University*

## EQUILIBRIA IN SYSTEMS CONTAINING ALCOHOLS, SALTS AND WATER, INCLUDING A NEW METHOD OF ALCOHOL ANALYSIS<sup>1</sup>

BY GEORGE BELL FRANKFORTER AND FRANCIS COWLES FRARY

In the course of some work involving potassium fluoride, it was observed that this substance would salt out ethyl alcohol from aqueous solution, and that it possessed this property over a very wide range of concentrations of alcohol and salt. The solid salt extracts quite a good deal of water from ordinary "95 percent" alcohol, forming either two liquid layers, or a mass of crystals overlaid by a layer of stronger alcohol. In contrast to the behavior of potassium carbonate, this dehydration appeared to take place in a very short time, and it was thought that potassium fluoride might become technically useful as a dehydrating agent for alcohol and similar organic liquids. It was also thought that its salting-out powers might make possible a new rapid method for the determination of alcohol, which would have advantages over the specific-gravity determination in point of speed, independence of weather conditions and adaptability to determinations where the direct determination of specific gravity would be impossible or inaccurate.

It is well known that the higher alcohols, acetone, and many other organic liquids can be precipitated from their aqueous solutions by addition of various salts. Potassium carbonate seems to be the only substance which is capable of salting out methyl alcohol,<sup>2</sup> while the carbonates and hydroxides of sodium and potassium, sulphates of sodium, ammonium, cadmium, manganese, iron (ferrous), cobalt, nickel, magnesium and zinc, alum, sodium phosphate, thio-

<sup>1</sup> Inaugural Dissertation, 1912. Published as Studies in Chemistry No. 1, Research Publications of the University of Minnesota. An abstract of this paper was published in the Proceedings of the Eighth International Congress of Applied Chemistry, 22, 87 (1912).

<sup>2</sup> Linebarger: Am. Chem. Jour., 14, 380 (1892).

sulphate and silicate, potassium phosphate, citrate and nitrate, ammonium nitrate and ammonium citrate<sup>1</sup> are all capable of producing two layers in solutions of ethyl alcohol under certain conditions. The phenomenon of salting out, or the formation of layers, is not confined exclusively to organic compounds in water solution, as Proctor<sup>2</sup> found that ammonia is salted out and forms two layers with a strong solution of either potassium carbonate or sodium silicate. Newth<sup>3</sup> re-recently rediscovered the salting out of ammonia by the carbonate.

The dehydration of alcohol by various chemical compounds has been studied by many chemists.<sup>4</sup> Of the various substances used, the commonest is lime, which gives an alcohol of nearly 100 percent. It causes, however, a large loss in alcohol, and is inconvenient on account of the large quantities of lime (0.55 kg. per liter, according to Kailan) required. The general theory of the drying action of a salt on a liquid, and the importance of choosing a salt which takes up a larger

---

<sup>1</sup> Pirnhaber: *Archiv des Apothekervereins Norddeutschland*, 7, 151 (1824); Linebarger: *Am. Chem. Jour.*, 14, 380 (1892); Brandes: *Pogg. Ann.*, 20, 586 (1830); Schiff: *Liebig's Ann.*, 118, 362 (1861); Proctor: *Chem. News*, 9, 25 (1864); Parmentier: *Comptes rendus*, 104, 686 (1887); Traube and Neuberg: *Zeit. phys. Chem.*, 1, 509 (1887); Bodländer: *Ibid.*, 7, 308 (1891); Dodge and Gratton: *Jour. Phys. Chem.*, 2, 498 (1898); de Bruyn: *Zeit. phys. Chem.*, 39, 641 (1902); Fleckenstein: *Phys. Zeit.*, 6, 419 (1905).

<sup>2</sup> *Chem. News*, 9, 25 (1864).

<sup>3</sup> *Jour. Chem. Soc.*, 77, 775 (1900).

<sup>4</sup> Soubeiran: *Liebig's Ann.*, 30, 356 (1839); Mendeléeef: *Zeit. Chemie*, 1865, 260; Erlenmeyer: *Liebig's Ann.*, 160, 249 (1871); Smith: *Chem. News*, 30, 235 (1874); Lescocour: *Bull. Soc. chim. Paris*, [3] 17, 18 (1897); Yvon: *Comptes rendus*, 125, 1181 (1897); Ostermeyer: *Pharm. Zeit.*, 43, 99; *Zeit. anal. Chem.*, 39, 654 (1900); Vitali: *Boll. chim. farm.*, 37, 257; *Zeit. anal. Chem.*, 39, 46 (1900); Bull: *Chem. Zeit.*, 24, 814, 845 (1900); Young: *Jour. Chem. Soc.*, 81, 707 (1902); Evans and Fetsch: *Jour. Am. Chem. Soc.*, 26, 1158 (1904); Winkler: *Ber. chem. Ges. Berlin*, 38, 3612 (1905); *Elektrochem. Werke Bitterfeld*, Brit. Pat. 31,567, Sept. (1906) and Ger. Pat. 175,780 Sept. (1905); Klason and Norlin: *Archiv Kem. Min. Geol.*, 2, 1 (1906); *Jour. Chem. Soc.*, 90, I, 921 (1906); Kailan: *Monatsheft*, 28, 927 (1907); Plücker: *Zeit. Nahr. Genussm.*, 17, 454; Pozzi-Escot: *Bull. Assoc. Chim. Sucr. Dist.*, 26, 580; Hess: U. S. Pat. 996,763; *Chem. Fabr. Griesheim Elektron*, Ger. Pat. 236,591; Foote and Sholes: *Jour. Am. Chem. Soc.*, 31, 1309 (1911).

percent of its weight in water have been discussed by Foote and Sholes.<sup>1</sup> Of the salts which can give a product containing over 97 percent alcohol, lime takes up 32 percent of its weight of water, anhydrous copper sulphate 11 percent, anhydrous zinc sulphate 11 percent, magnesium sulphate 15 percent, anhydrous barium chloride 7.7 percent, and anhydrous potassium carbonate 13 percent. According to the results of Foote and Sholes, the lowest hydrates of these substances are in equilibrium with 99.5, 99.5, 99.4, 99.4, 98.4, and 99.3 percent alcohol, respectively, at 25°. At boiling temperatures, however, Kailan found that he could get 99.9 percent alcohol by the use of lime. Potassium fluoride, absorbing 62 percent of its weight of water to form the lowest hydrate, and being in equilibrium at this point with 97.5 percent alcohol, according to work described herein, certainly deserves to rank well among drying agents for liquids miscible with water, and by virtue of the speed with which it absorbs this water, it has many advantages over lime and potassium carbonate, which are notoriously slow to reach equilibrium. Foote and Sholes state that the equilibrium with magnesium sulphate was reached very slowly, and experience with copper sulphate will convince any one that it is not a rapid dehydrating agent. Calcium carbide, calcium, aluminum and magnesium and their amalgams have been used to remove the last trace of water.

Among organic chemists, it is quite common to dry certain liquids over a saturated solution of potassium carbonate. This has the advantage over the use of the solid salt that the loss of liquid, mechanically, is less, and it is much quicker. Any salt which would be suitable for this purpose must have a decided "salting-out" power, and its saturated solution must have a low vapor tension. With the exception of potassium carbonate, and the hydroxides of sodium and potassium, none of the salts named above as able to salt out alcohol are deliquescent, so that their hydrates,

---

<sup>1</sup> Jour. Am. Chem. Soc., 33, 1309 (1911).



not to speak of their saturated solutions, have relatively large vapor tension. By plotting the results of Foote and Sholes, the curve shown in Fig. 1 is obtained, showing the vapor

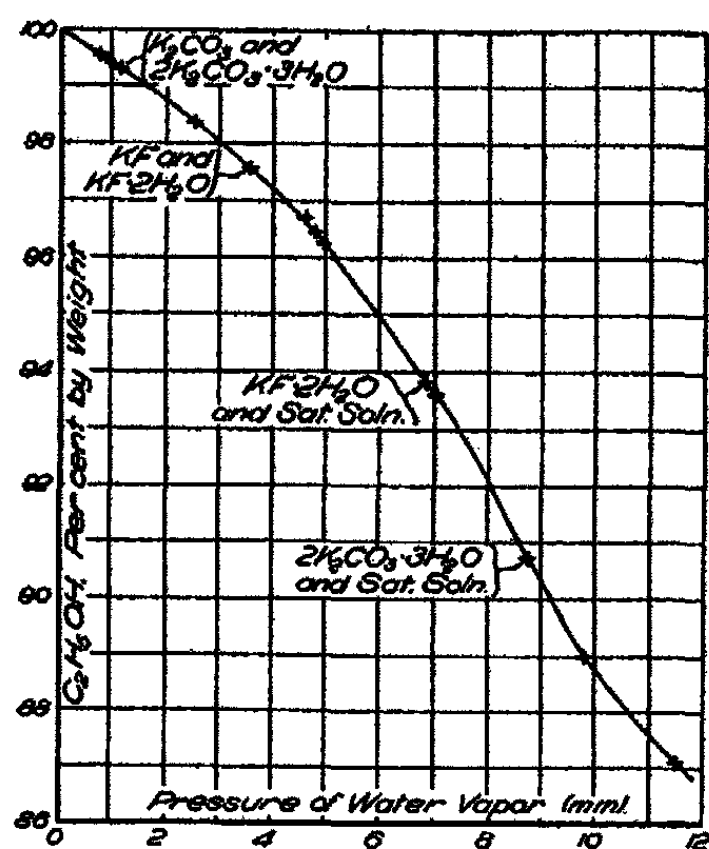

Fig. 1—Equilibrium between Alcohol, Water Vapor, and Salts

tension of the water in strong alcohol. The solutions of alcohol with which saturated solutions of potassium carbonate and fluoride and the solid hydrates are in equilibrium, when plotted on this curve, give the approximate value of their vapor tension. It will be seen that while the vapor tension of the hydrate of potassium carbonate is lower than that of the hydrate of the fluoride, the saturated solution of the latter has a lower vapor tension than that of the former, and hence is a better drying agent. From this curve it appears that, neglecting the effect of the small amount of dissolved potassium fluoride on the vapor tension of the alcohol, the vapor tension of the saturated solution of the fluoride is 6.9 mm, and that of the solid hydrate 3.5 mm.

The fact that potassium fluoride "salts out" alcohol from aqueous solution seems never to have been mentioned in the literature, although it must have been noticed by

Berzelius<sup>1</sup> who first described the salt, and was amazed by its power to slowly etch glass. He attempted to extract the free acid which he supposed must be present, by shaking the concentrated solution with alcoholic potash, but found the salt unchanged by this treatment. Rose<sup>2</sup> must also have noticed the salting out, as he tried to separate the fluoride into an acid salt and free potash by recrystallization, and when this did not work, by precipitation with alcohol. He speaks of treating a very concentrated solution of the salt with strong alcohol, "by which only potassium fluoride containing water was precipitated, while a very small amount of potassium fluoride remained dissolved in the alcohol." He is evidently speaking of the precipitation of the hydrate in crystalline form, as he says again, after speaking of the difficulty of obtaining the hydrate in crystalline form from an aqueous solution by ordinary means: "This [hydrate] is obtained more easily if one adds strong alcohol to a concentrated solution of potassium fluoride. Only a little of the salt is dissolved, the greater part of it precipitates in a hydrated form (im wasserhaltigen Zustand)." He determined the percentage of water in the hydrate, mentioning especially that two samples were precipitated by alcohol and dried between filter papers. His analyses indicate that he was working with the hydrate  $\text{KF} \cdot 2\text{H}_2\text{O}$ , which has since been analyzed and identified as the only one formed at ordinary temperatures, by Guntz,<sup>3</sup> Fremy,<sup>4</sup> Mylius and Funk<sup>5</sup> and de Forcrand.<sup>6</sup> The latter author has also shown the existence of a hydrate  $\text{KF} \cdot 4\text{H}_2\text{O}$ , formed below  $20^\circ$ , and melting at  $19.3^\circ$ , while the other hydrate melts at  $41^\circ$ . The person who comes the nearest to mentioning the salting-out power of this salt is Carnot,<sup>7</sup> who, in purifying some of it, mentions adding strong

<sup>1</sup> Pogg. Ann., 1, 11 (1824).

<sup>2</sup> Ibid., 55, 538 (1842).

<sup>3</sup> Ann. Chim. Phys., [6] 3, 17 (1889).

<sup>4</sup> Ibid., [3] 47, 27 (1856).

<sup>5</sup> Ber. chem. Ges. Berlin, 30, 1716 (1897).

<sup>6</sup> Comptes rendus, 152, 1073 (1911).

<sup>7</sup> Bull. Soc. chim. Paris, [3] 9, 71 (1893).

alcohol to the solution until a slight cloudiness appears, allowing to stand, and filtering, apparently for the purpose of removing fluosilicates.

Aside from the work above mentioned, there is very little literature on the properties of the neutral potassium fluoride or its solutions, and none on its preparation.<sup>1</sup> It would seem that very few people have ever used it, and it is not listed in most chemical price-lists.

The precipitation of a liquid from water by the addition of a salt comes under that general class of equilibria in ternary mixtures where two liquid phases are possible. The general theory of such systems, and the form of the isotherms obtained, have been very thoroughly discussed by Schreinemakers.<sup>2</sup> There are four classes into which such equilibria are divided: (1) each of the three components forms a binary system having two liquid phases when mixed with either of the other components; (2) two liquid phases are found in two of the possible binary systems above mentioned but not in the third; (3) in only one of the binary systems can two liquid layers appear; (4) each component, mixed with either of the others, gives a system with only one liquid phase, *i. e.*, a solution of one in the other, and only when all three are present can two liquid phases exist. All the above classes refer to stable systems only, all four are realizable experimentally, and examples of each have been studied. The salting-out of the alcohols here studied comes under the fourth class, since neither in the system alcohol-water, alcohol-salt (free from water) nor water-salt can two liquid layers be formed, but when all three are present in certain proportions such layers are formed within certain limits of temperature.

In representing ternary systems, Schreinemakers and

<sup>1</sup> F. W. Clarke: *Am. Jour. Sci.*, [3] 13, 291 (1879); Kohlrausch: *Wied. Ann.*, 6, 17 (1879); Guntz: *Comptes rendus*, 97, 256 (1883); Tammann: *Wied. Ann.*, 24, 530 (1885); Petersen: *Zeit. phys. Chem.*, 4, 384 (1889); Ditte: *Comptes rendus*, 123, 1281 (1896); 124, 29 (1897); Pauli: *Zeit. Elektrochemie*, 3, 474 (1897); Tanatar: *Zeit. anorg. Chem.*, 28, 255 (1901); Fox and Herz: *Ibid.*, 35, 129 (1903); Karadeef: *Centr. Min.*, 1909, 728; *Chem. Abs.*, 4, 433 (1911).

<sup>2</sup> *Zeit. phys. Chem.*, 22, 93, 515; 23, 649 (1897).

others have employed a system of coördinates founded on the equilateral triangle. If the three vertices of the triangle ABC (Fig. 2) represent the three pure components, points on the side AB of the triangle represent mixtures of the two substances A and B, while any point within the triangle represents a mixture containing all three substances. In plotting such a point, distances are measured parallel to the sides of the triangle, the distance thus measured to any side showing the percent of the component which is represented by

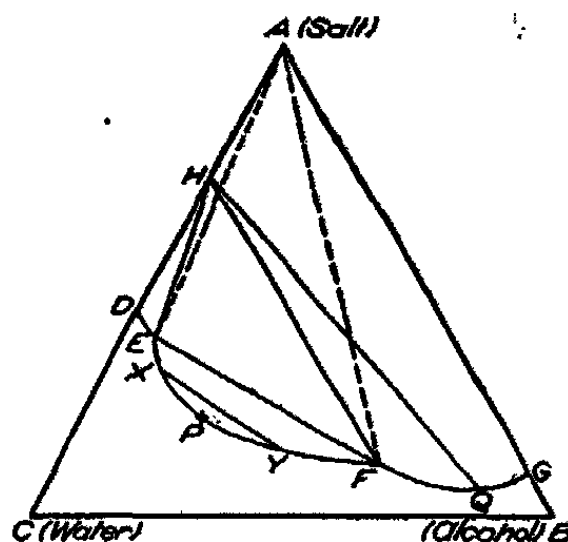

Fig. 2—General Form of the Isotherms in a Ternary System of the Fourth Class

the vertex opposite to that side. Since the sum of such distances is equal in length to a side of the triangle, such sum is 100 percent, and any possible percentage composition of the mixture can be represented by a point within the triangle, and every point within the triangle represents a possible mixture of all three components. In such a triangle there will always be a line which marks the boundary between the homogeneous and heterogeneous systems. In the case which we are considering, where one of the components is a solid, this curve at a given temperature will in general consist of three parts:

(1) a line DE (Fig. 2) starting from the point D which represents the composition of a saturated solution of the salt in water, and running to that point E within the triangle, which represents the composition of the lower of the two

liquid layers which are in equilibrium with the hydrate of the salt (if it forms one at that temperature). This point may be considered to be that saturated solution of the salt in water, which has then been saturated with alcohol. In general, the addition of the alcohol reduces the percentage of the salt in the mixture, by precipitation of part of the salt. This point E then represents a saturated solution of salt in water, in which part of the salt has been replaced by alcohol until the further addition of alcohol produces no change in the composition of the solution.

(2) From this point E a line EPF runs to the point F representing the composition of the upper layer (alcoholic solution of the salt and water) which is in equilibrium with the solution at E, and also with the hydrate of the salt (or the anhydrous salt, if no hydrate exists under the given conditions). The point at which these two solutions coexist is a quadruple point, since four phases (a solid, two liquids and a vapor) are present. Since there are but three components in the four phases, the system at this point has but one degree of freedom, *i. e.*, at a given temperature the system is invariant, and the conjugate solutions (E and F) can each have only one definite composition.

(3) From the point F, representing the composition of the upper layer at the quadruple point, a line runs to the point G, representing the composition of the saturated solution of the salt in the alcohol.

In general, each of these three lines is concave toward the vertex representing the salt. The line DE is the locus of all aqueous solutions saturated with respect to the salt, and of alcoholic content varying from none to the maximum possible in the saturated salt solution (at the quadruple point E). The line EPF, commonly called the binodal curve, is the locus of all conjugate solutions, *i. e.*, if we have two liquid phases in the system at the given temperature, the composition of each will be represented by a point on this line, as X and Y. The line FG represents the solubility of the salt and its various

hydrates in alcohol-water mixtures from the composition represented at F to absolute alcohol.

In Fig. 2, mixtures represented by points within the area DEPFGB are homogeneous, those within the area HDE (if H be the point representing the composition of the hydrate of the salt which is stable at that temperature) will consist of a mixture of the solid hydrate and a solution having a composition represented by some point on the line DE. A mixture lying within the triangle HEF will consist of the solid hydrate and the two solutions represented by points E and F, which by definition are the only two solutions which can be in equilibrium with the solid hydrate when both water and alcohol are present in sufficient quantity to give two liquid phases. Mixtures within the area EPF will consist of two conjugate solutions whose composition will be represented by two points on the binodal curve EPF. The point P is the "plait point," *i. e.*, the point of union of the two branches of the binodal curve which represent the composition of the upper and lower layers, respectively. To state it from another view-point, a mixture whose composition was represented by the point P would be homogeneous, but the addition of an infinitesimal portion of the salt would cause it to separate into two layers having compositions represented by points on the binodal curve lying very close to P, one a little to the right and the other a little to the left. By determining analytically the composition of two conjugate solutions X and Y, and calculating the composition of the mixture containing varying quantities of each, it may be shown that the locus representing such mixtures is the straight line XY, which is called a tie-line.

Any mixture whose composition is represented by a point within HFQ will separate into the solid hydrate and a solution lying along FQ, where Q represents the composition of the alcoholic solution which is in equilibrium with both the hydrate and the anhydrous salt. This is the solution to which the anhydrous salt dehydrates weaker alcohol. The triangle AHQ contains all mixtures of the hydrate and anhydrous

salt in equilibrium with alcoholic solution Q. The area AQQ consists of mixtures of the anhydrous salt and alcoholic solutions of it having a composition represented by a point on line QG.

If the salt does not form a hydrate, the point H may be considered as moving along CA to coincide with A, while Q moves along BF and coincides with F as indicated by the broken lines. Area AHFQ disappears entirely, as it is the area over which the hydrate existed in equilibrium with an alcoholic solution of itself, and H becomes A, and Q becomes F in the above discussion.

#### Experimental Methods

*The Binodal Curve.*—The point at which an inhomogeneous solution of the salt, alcohol and water just becomes homogeneous is a point on the binodal curve, and the determination of a number of such points enables one to plot this curve accurately. Such points were determined for the different alcohols and salts as follows: An Erlenmeyer flask with a well-ground glass stopper was cleaned, dried and weighed. With potassium fluoride, the salt was ignited in a weighed, covered platinum crucible; weighed, as much as possible transferred to the flask, and the rest rinsed into the flask with distilled water. In this way the weight of the anhydrous salt was accurately obtained, as an experiment showed that with the crucible covered, in the dry winter air of this climate, the increase in weight during seven minutes in the open air was only 0.0007 gram. In the case of large weights of the fluoride, this precaution was considered unnecessary, as the possible percentage error was negligible; the salt was then weighed in the stoppered flask, as was also done in the case of the other salts. The salt was next dissolved in distilled water, and the whole weighed. Enough alcohol to form two liquid phases was then added, together with a trace of the solid dye used as an indicator. The flask was again weighed, water added from a burette until the solution just became homogeneous and clear, the flask weighed

again, and the addition of alcohol and water repeated until a series of results was obtained.

All weighings of solutions were made on a large Sartorius balance, of ample carrying capacity, and easily sensitive to 0.5 mg. with a load of 500 grams on each pan, but no attempt was made to weigh closer than the nearest milligram. It is not claimed that the end-point of the titration could generally be determined closer than 0.1 to 0.2 gram water, but it was thought best to weigh to milligrams to minimize cumulative errors in the amounts of water and alcohol present. When a solution had to stand long enough between determinations to lose weight appreciably, the loss was determined as noted in the tables, and divided between the alcohol and water in proportion as each was present. This was done on the theory that the loss was caused by evaporation of the solution which was in the ground joint. Such loss was usually less than 30 mg. None of the flasks used showed any signs of the slightest etching by the fluoride, and weighing before and after use showed the loss from such etching, and therefore the contamination of the solution, to be negligible.

Spirit blue was used as an indicator, and gave very good results, except with potassium carbonate, which bleached it quickly. Phenolphthalein was later used with this salt, a few minute crystals of the solid being sufficient. The function of the indicator was to color the alcoholic upper layer, and render it easily visible when only a trace of it was present.

No attempt was made to work in a thermostat, or to control the temperature very closely, as it was found that in most cases a variation of 2° or 3° produced a negligible change in the end-point, and if the results were to be used as a basis of an analytical method, it would be better to determine the curve under such temperature conditions as would be practical in its use. With propyl alcohol, where temperature was found to be more important than with the rest, the temperature was frequently taken with a calibrated thermometer, and kept as close as possible to that of the room (20° to 25° C.). The heat of dilution of the salts and alcohol, and that of the



hands tended to keep the temperature a little higher than that of the laboratory, and where not otherwise stated, the temperature may be assumed to have been between 23° and 26° C. Care was taken to avoid loss by evaporation or other cause during a series, and whenever a thermometer was introduced, it was done just before a fairly large quantity of either alcohol or water was to be added, and the latter was used to wash off the bulb as the thermometer was withdrawn.

*Specific-Gravity Determinations.*—All specific-gravity determinations were made with the pycnometer, weighing in a room whose temperature was within a degree or two of that of the alcohol. Two 50 cc. pycnometers were used. They were of the type which has a thermometer ground into one neck of the flask and a capillary tube in the other neck. The capillary was always filled to a definite mark, and covered with a cap when weighing. The alcohol was never allowed to expand enough during the weighing to reach the top of the capillary. Pycnometer No. 1, used in all determinations except those on methyl alcohol, was carefully standardized by repeated weighings empty and full of distilled and redistilled water at a temperature of 15.55° C. This temperature was used in all determinations with this pycnometer, except a few with propyl alcohol, *q. v.* Pycnometer No. 2 was similarly standardized at 4.00° C., for use with methyl alcohol, since the tables of Dittmar and Fawsett refer to water at that temperature. In all pycnometer determinations, great care was taken that the alcohol in the apparatus was kept thoroughly stirred, by frequently rotating the pycnometer rapidly about its axis. Since the room was at approximately the correct temperature, it was easy to control the temperature of the alcohol within 0.05° and fill the pycnometer exactly to the mark at the desired temperature. Duplicate determinations generally agreed within 0.00005. The thermometers in both instruments were graduated to 0.2° and could easily be read to 0.05°. They were standardized by comparison with a certified standard graduated to 0.02°.

Hehner's tables for ethyl alcohol and Dittmar and Faw-

sett's for methyl alcohol were used. For weak solutions of propyl alcohol the recent table of Doroshevskii and Rozhdestvenskii<sup>1</sup> was used, and for the strong alcohol a table constructed as explained later under propyl alcohol. For weak propyl alcohols, the determinations were made at 15.0/15.55°, and considered to be close enough to the conditions of Doroshevskii and Rozhdestvenskii (15/15°).

#### Materials

*Methyl Alcohol.*—This was Kahlbaum's absolute methyl alcohol. Its specific gravity was taken at 15.55/4.00°, and three determinations gave 0.795762, 0.795875 and 0.795877. Dittmar and Fawsett give the specific gravity of absolute methyl alcohol at 15.55/4.00° as 0.79589. The agreement was considered satisfactory, and the alcohol was figured as 100 percent pure in the calculations.

*Ethyl Alcohol.*—Ordinary "95 percent" alcohol was digested with silver nitrate and caustic potash to remove aldehydes, and then twice distilled. Ten liters of this were prepared and thoroughly mixed. It was preserved in large glass-stoppered bottles, from which portions of about 500 cc were poured off into a smaller bottle for use as needed, thus preserving the main portion from possible contamination. The specific gravity of this alcohol was taken at 15.55/15.55°, and the following results obtained: 0.81923, 0.81920, 0.81916, 0.81919. From the average of the above determinations, it was found that the preparation contained 91.28 percent by weight of absolute ethyl alcohol.

*Propyl Alcohol.*—For the determination of the binodal curves Merck's normal propyl alcohol was used. It contained some water, and possibly some isopropyl alcohol. On distilling 100 cc of it, 24 cc came over between 91 and 94° C, and 63 cc between 94 and 99°. Partial drying of this alcohol with anhydrous potassium fluoride seemed to increase

<sup>1</sup> Jour. Russ. Phys. Chem. Soc., 41, 1428; Chem. Zentr., 1910, I, 812; Chem. Abs., 5, 409 (1911).

the proportion of the upper fraction. It is well known that the presence of water lowers the boiling point of propyl alcohol, the constant boiling mixture boiling below  $90^{\circ}$ . The specific gravity of this alcohol was taken at  $20.0/15.55^{\circ}$ , and the values found were 0.80812 and 0.80824. Some of the alcohol was treated with magnesium amalgam in excess, with which it reacted quite vigorously at first, and more slowly later. It stood with this for two weeks, with occasional shaking. Most of the action ceased within a few hours, but some slow action was noticeable for several days. The clear liquid was filtered into a distilling flask and distilled, care being taken to protect the distillate from the air. Distillation began at  $95^{\circ}$ , and practically all of the liquid distilled over below  $99^{\circ}$ . At  $15.55/15.55^{\circ}$  the distillate had a specific gravity of (1) 0.80644, (2) 0.80647, average 0.80646. The specific gravity of absolute propyl alcohol is given<sup>1</sup> as 0.8066 at  $15^{\circ}$  which is in good agreement with the above. Very recently Doroshevskii and Rozhdestvenskii<sup>2</sup> have found a higher value (0.80804) but details of the purification of their material were not available to me. They appear to be the first ones to have worked out a complete table of specific gravities of the mixtures of normal propyl alcohol and water, but as their absolute alcohol was heavier than ours, we have used their table only for very dilute solutions. Using the absolute alcohol described above (71 grams) in a glass-stoppered Erlenmeyer flask, we added successive amounts of distilled water, making duplicate determinations of the specific gravity of the diluted alcohol resulting from each addition. The amount of diluted alcohol remaining in the flask after each set of determinations was carefully weighed before adding fresh water, and the weight of absolute alcohol in it calculated afresh from its known strength, to correct for losses of the diluted alcohol. The following results were obtained:

<sup>1</sup> Linnemann: *Liebig's Ann.*, 161, 26 (1872).

<sup>2</sup> *Jour. Russ. Phys. Chem. Soc.*, 41, 1428; *Chem. Zentr.*, 1910, I, 812  
*Chem. Abs.*, 5, 409 (1911).

TABLE 1

Alcohol, percent by weight	Specific gravity at 20.00/15.55°		
	(a)	(b)	Average
100.00	0.80319	0.80309	0.80314
98.065	0.80587	0.80582	0.80585
97.997	0.80829	0.80834	0.80831
96.21	0.81252	0.81255	0.81253
94.28	0.81679	0.81679	0.81679
92.27	0.82125	0.82121	0.82123
90.15	0.82578	0.82573	0.82576
86.77	0.83292	0.83291	0.83291

These results were plotted and formed a smooth curve. From this curve and the above results, the following table representing the percent of normal propyl alcohol in distillates from Merck's propyl alcohol (which may be taken as perhaps typical of the best commercial alcohol) was constructed:

TABLE 2

Alcohol, percent	Sp. Gr. at 20.00/15.55°	Alcohol, percent	Sp. Gr. at 20.00/15.55°
100.00	0.80314	92.00	0.82185
99.00	0.8058	91.00	0.82395
98.00	0.8083	90.00	0.8261
97.00	0.8108	89.00	0.82825
96.00	0.8130	88.00	0.83035
95.00	0.8153	87.00	0.8325
94.00	0.8175	86.00	0.8346
93.00	0.8197	—	—

This table was used to determine the strength of all high-proof alcohol obtained in the following work. According to it, Merck's alcohol, which was used for most of this work, contained 98.07 percent by weight of absolute alcohol.

The quadruple-point determinations, and determinations of the solubility of salts in strong propyl alcohol were made with some of the above alcohol which had been once used in work on the binodal curves, salted out and recovered, and

distilled in a fractionating apparatus. The alcoholic portions were dried with anhydrous potassium fluoride, and fractionated twice. The distillate from 90 to 97° had a specific gravity of 0.80986 (97.26 percent), that from 97 to 98° 0.80418 (99.60 percent), and that from 98 to 100° 0.80385 (99.73 percent). The fraction boiling above 100° was rejected, and that from 90 to 97° set aside for further purification. The two fractions left (97 to 100°) were mixed and found to have a specific gravity of 0.80413 (99.63 percent).

*Potassium Fluoride.*—Merck's C. P. potassium fluoride was used, except in some preliminary experiments. The salt when freshly dissolved was neutral to phenolphthalein, but the solution quickly became slightly alkaline. Several grams of it dissolved in distilled water and acidified with nitric acid gave only a slight opalescence with silver nitrate. It was readily and completely soluble in water (except when the solution was nearly saturated, when cloudiness was noticed), and hence could have contained only a trace of fluosilicate. No appreciable amount of sodium could be shown by the spectroscope. 7.26 grams of it, after fuming down with sulphuric acid, diluting and boiling with nitric acid, gave only 0.0002 gram of material precipitated by ammonia and ammonium chloride. Tests for calcium and magnesium in the filtrate gave negative results. An attempt to remove the trace of fluosilicate present by treating with a little of Merck's best hydrofluoric acid, evaporation and ignition in platinum seemed rather to increase the amount of insoluble matter, so the salt was used as it was, after ignition from 5 to 10 minutes at moderate red heat, and cooling (covered) in a desiccator.

*Potassium Carbonate.*—Merck's potassium carbonate "Highest Purity, Medicinal" was used. At first the solid salt was simply ignited and weighed, but some suspended matter was present and very troublesome, so a large amount of the salt was dissolved in a little more than its own weight of water, filtered by suction, and portions of this solution evaporated in platinum and heated to red heat as needed. The insoluble matter seemed to consist of iron compounds,

with some lighter colored material. The solubility of the salt at room temperature was determined by evaporation and ignition of weighed quantities of the filtered saturated solution which had stood at least a week in contact with the hydrate. Duplicate determinations, two weeks apart, gave 53.05 and 53.07 percent of the solution as anhydrous carbonate.

*Sodium Chloride.*—Kahlbaum's sodium chloride "C. P. zur Analyse" was used, the crystals being ignited for several minutes and cooled in a desiccator before weighing. Its solubility was determined as in the case of the carbonate, duplicate determinations giving 26.35 and 26.31 percent of the solution as chloride, or 35.78 and 35.70 grams salt dissolved in 100 grams of water. Armstrong and Eyre<sup>1</sup> state that they find that the solubility at 25° varies somewhat in different samples. They found the values 35.71, 35.77, 35.83, 35.78, 36.08, and 36.19 grams per 100 grams water, while previously<sup>2</sup> they had found 36.14, 36.14, 36.22 and 36.23 grams. I have therefore taken the mean of my determinations as the solubility of my sample, and plotted it in the proper place. (See the system propyl alcohol, water, sodium chloride.)

#### **Equilibrium between Potassium Fluoride, Ethyl Alcohol and Water**

This has never previously been studied. The literature on potassium fluoride, and the statements of those who may have noticed its salting-out power, have been given on page 406. Points on the binodal curve were determined at room temperature, according to the methods previously described, and are given in Table 3. The effect of a change in temperature on the binodal curve is very small, apparently less than with potassium carbonate, and the results may be considered as being sufficiently accurate at any temperature between 23 and 26°. For determination of the concentration at the quadruple point where the two layers E and F (Fig. 2)

<sup>1</sup> Proc. Roy. Soc., 84A, 123 (1910).

<sup>2</sup> Ibid., 79A, 566 (1907).

are in equilibrium with the solid hydrate  $\text{KF} \cdot 2\text{H}_2\text{O}$  and their vapor, three separate determinations of the alcohol content of the upper layer were made. In an Erlenmeyer flask were placed a couple of hundred cubic centimeters of the aldehyde-free alcohol, water and quite a little potassium fluoride were added, the mixture warmed until all the hydrate formed was melted, shaken vigorously for some time, then cooled to room temperature with shaking. If the hydrate did not crystallize out in quite a large quantity, more of the anhydrous salt was added and the process repeated. When a sufficient amount of the crystalline hydrate appeared to be forming, the mixture was allowed to stand a week or more at room temperature, with frequent shaking, and then part of the upper liquid was cautiously poured off from the mixture of crystals and saturated solution, and carefully distilled to dryness. The specific gravities of the distillates obtained by three such experiments were 0.81283, 0.81221 and 0.81243, showing that the solvent in the upper layer at this point contained 93.63, 93.85, and 93.78, or an average of 93.75 percent alcohol by weight, and 6.25 percent water. Two portions of 20.14 and 10.43 grams of these solutions gave, respectively, 0.2640 and 0.1193 gram of potassium fluoride, after evaporation in platinum and ignition. This indicates that at the quadruple point where we have two liquid phases, the upper one contains 93.75 grams alcohol, 6.25 grams water, and 1.25 grams of potassium fluoride per 100 grams of solvent, or 92.69 percent alcohol, 6.07 percent water and 1.23 percent potassium fluoride by weight.

An alcohol determination in the lower layer, decanted off from the crystals and separated from the upper layer, gave the following result: 166.86 grams of the solution, to which some water had been added, were distilled for some time after the thermometer in the distilling flask had become stationary at  $100^\circ$ . Distilled water was added to the distillate, and the whole weighed 123.60 grams. This had a specific gravity of 0.99828 at  $15.55/15.55^\circ$ , and therefore contained 0.90 percent by weight, or 1.11 gram alcohol. This would give the lower

TABLE 3—BINODAL CURVE FOR THE SYSTEM: WATER, ETHYL ALCOHOL, POTASSIUM FLUORIDE. DETERMINED AT ROOM TEMPERATURE. 91.28 PERCENT ALCOHOL USED

Solvent added		Total weight present			Grams per 100 g. solvent			Percent by weight		
Water	Alcohol	KF	H <sub>2</sub> O	C <sub>2</sub> H <sub>5</sub> OH	KF	H <sub>2</sub> O	C <sub>2</sub> H <sub>5</sub> OH	KF	H <sub>2</sub> O	C <sub>2</sub> H <sub>5</sub> OH
50.833	34.382	11.658	53.832	31.383	13.680	63.17	36.83	12.03	55.57	32.40
4.627	8.935	11.658	59.238	39.539	11.802	59.97	40.03	10.56	53.64	35.80
3.428	7.628	11.658	63.331	46.502	10.614	57.66	42.34	9.60	52.13	38.28
6.368	19.234	11.658	71.376	64.059	8.608	52.70	47.30	7.93	48.52	43.55
3.781	17.448	11.658	76.678	79.986	7.441	48.94	51.06	6.93	45.55	47.52
8.578	36.201	11.658	88.412	113.031	5.787	43.89	56.11	5.47	41.49	53.04
6.700	34.047	11.658	98.080	144.110	4.813	40.50	59.50	4.59	38.64	56.77
6.284	39.059	11.658	107.770	179.763	4.054	37.48	62.52	3.90	36.02	60.08
5.290	36.963	11.658	116.283	213.503	3.535	35.26	64.74	3.41	34.06	62.53
6.383	60.504	11.658	127.941	268.732	2.939	32.25	67.75	2.86	31.33	65.81
33.613	0.693	24.619	33.673	0.633	71.762	98.15	1.85	41.78	57.14	1.08
5.662	0.516	24.619	39.380	1.104	60.811	97.27	2.73	37.82	60.49	1.70
6.032	0.672	24.619	45.471	1.717	53.387	96.36	3.64	34.81	62.82	2.37
5.316	0.886	24.619	50.855	2.535	46.111	95.25	4.75	31.56	65.19	3.25
6.833	1.544	24.619	57.823	3.944	39.857	93.61	6.39	28.50	66.93	4.57
7.941	2.718	24.619	66.001	6.425	33.992	91.13	8.87	25.37	68.01	6.62
11.344	6.210	24.619	77.887	12.093	27.360	86.56	13.44	21.48	67.96	10.55
6.223	6.370	24.619	84.665	17.908	24.001	82.54	17.46	19.36	66.56	14.08



31.666	0.416	26.623	31.702	0.380	82.985	98.82	1.18	45.35	54.00	0.65
18.266	1.811	26.623	50.126	2.033	51.042	96.10	3.90	33.79	63.63	2.58
11.720	2.323	26.623	62.049	4.153	40.215	93.73	6.27	28.68	66.85	4.47
9.093	3.417	26.623	71.441	7.272	33.823	90.76	9.24	25.27	67.82	6.91
15.137	9.786	26.623	87.430	16.205	25.688	84.36	15.64	20.44	67.12	12.44
6.511	6.778	26.623	94.532	22.392	22.770	80.85	19.15	18.55	65.85	15.60
11.391	18.162	26.623	107.507	38.970	18.176	73.40	26.60	15.38	62.11	22.51
7.068	15.851	26.623	115.957	53.439	15.717	68.45	31.55	13.58	59.15	27.27
10.633	26.255	26.623	128.879	77.405	12.906	62.48	37.52	11.43	55.34	33.23
5.404	14.772	26.623	135.571	90.889	11.756	59.87	40.13	10.52	53.57	35.91
25.390	22.357	5.039	27.339	20.408	10.554	57.26	42.74	9.55	51.79	38.66
2.819	9.152	5.039	30.956	28.762	8.439	51.84	48.16	7.78	47.81	44.41
3.397	12.333	5.039	35.428	40.020	6.679	46.96	53.04	6.26	44.02	49.72
2.226	10.871	5.039	38.602	49.943	5.691	43.60	56.40	5.39	41.25	53.36
3.728	20.921	5.039	44.154	69.040	4.452	39.01	60.99	4.26	37.35	58.39
3.149	20.849	5.039	49.121	88.071	3.673	35.80	64.20	3.54	34.53	61.93
3.021	27.001	5.039	54.496	112.718	3.014	32.59	67.41	2.93	31.64	65.44
2.369 <sup>1</sup>	31.867	5.023	59.467	141.436	2.500	29.60	70.40	2.44	28.88	68.68
2.613	53.998	5.023	66.789	190.725	1.951	25.94	74.06	1.91	25.44	72.64
2.198	71.807	5.023	75.248	256.271	1.515	22.70	77.30	1.49	22.36	76.15
79.905	1.391	66.712	80.027	1.269	82.061	98.44	1.56	45.07	54.07	0.86
7.348	0.464	66.712	87.415	1.693	74.866	98.10	1.90	42.81	56.10	1.09
6.749	0.472	66.712	94.205	2.124	69.254	97.80	2.20	40.92	57.78	1.28
					1.171	15.72	84.28	1.16	15.54	83.30

<sup>1</sup> Part of preceding solution lost in transferring to a new flask.

solution an alcohol content of 0.67 percent by weight, or 1.28 grams per 100-gram solvent.

The points on the binodal curve were determined as previously described, except the point at 84.28 percent alcohol, which was determined by distillation of the alcohol from the upper one of two conjugate solutions, and determination of the specific gravity of the distillate. The percent of potassium fluoride was determined by evaporation of a weighed amount of this solution in a platinum dish, and ignition.

Two sets of conjugate solutions were taken, and the fluoride content of each determined, in order to locate tie-lines and get the approximate position of the plait-point. Since there was a loss of hydrofluoric acid possible during the evaporation of solutions containing such a large proportion of water, an excess of concentrated hydrochloric acid was added to each sample, after weighing it into the platinum dish, and the salt weighed as chloride after evaporation and cautious ignition. In the first determination 13.60 and 7.61 grams of the upper and lower solutions, respectively, gave 0.7793 and 2.0435 grams chloride, equivalent to 0.6073 and 1.5926 grams fluoride. The two conjugate solutions then contained 4.47 and 20.9 percent by weight of potassium fluoride, or 4.68 and 26.55 grams per 100 grams solvent. By reference to Table 4, these solutions were found to contain 14.4 and 60.0 grams alcohol per 100 grams solvent, or 11.9 and 57.4 percent by weight of alcohol. Similar determinations of another set of conjugate solutions showed them to contain 9.68 and 18.59 grams potassium fluoride and 44.8 and 25.84 grams alcohol per 100 grams solvent, or 8.82 and 15.7 percent potassium fluoride and 41.0 and 21.8 percent alcohol by weight. These two sets of conjugate solutions have been plotted, the tie-lines drawn, and plait-point indicated in Fig. 3.

A good many experiments were made to determine accurately the position of the second quadruple point, where the two solid phases (anhydrous salt and hydrate) were in equilibrium with a liquid and a vapor phase. Preliminary

experiments showed that using ordinary commercial alcohol (about 92 percent by weight) and the anhydrous fluoride, heating to boiling, cooling again to ordinary temperature and allowing to stand a short time to crystallize out excess of the hydrate, gave about 96 percent alcohol. In various other trials it was found easy to get from 96 to 96.5 percent alcohol, but difficult to go above that amount by this method (heating and cooling). Some alcohol which had been treated several times in this way was heated with quite a little of the anhydrous salt in a pressure flask for several hours on a water bath, with no apparent change. It was then allowed to stand

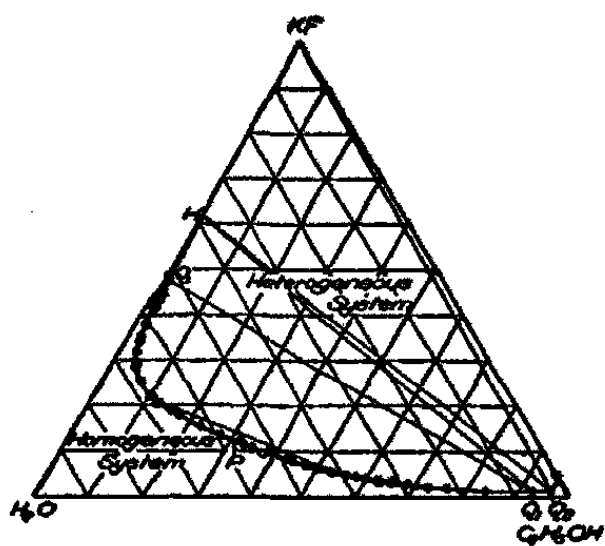

Fig. 3—Equilibrium in the System: Potassium Fluoride, Ethyl Alcohol, Water

about eight months at room temperature, unopened. Upon filtering and carefully distilling to dryness, the alcohol had a specific gravity of 0.80196 at 15.55/15.55°, corresponding to 97.37 percent by weight of alcohol. Some of the alcohol from previous treatments (96.13 percent by weight) was refluxed with more fluoride, decanted off (hot) from the undissolved salt, allowed to stand until crystals of the hydrate formed, and then cooled to about  $-7^{\circ}$  for an hour or two. After filtering through glass wool and distilling, the distillate was found to contain 96.85 percent of alcohol, while a portion removed after only standing at room temperature contained 96.5 percent. This process of refluxing and cooling to  $-5$

or  $-7^{\circ}$  was then repeated three times, and then upon distilling 97.3 percent alcohol was obtained. The process of refluxing and cooling was then repeated six times, decanting into the same flask each time. The alcohol was then refluxed again, decanted back into the same flask, allowed to stand ten days at room temperature with this hydrate, decanted off, a weighed portion evaporated and ignited in platinum to determine the fluoride in solution, and the rest distilled to dryness for the alcohol determination. The distillate had a specific gravity of 0.80157 at  $15.55/15.55^{\circ}$ , and thus consisted of 97.50 percent alcohol. 19.94 grams of the solution gave 0.3025 gram of potassium fluoride, which is 1.541 grams per 100 grams solvent or 1.52 percent of the solution by weight.

A number of samples of alcohol of various strengths obtained from previous treatments, containing perhaps 96 percent alcohol, were mixed and ground several days with some fluoride in an Abbé ball mill. The stones and the glaze of the mill were somewhat attacked. On decantation and distillation an alcohol having a sp. gr. of 0.80172 (97.46 percent by weight) was obtained. About 50 grams of fluoride was added, and the mixture ground for five days more. A large amount of fluosilicate had now been formed, and on decanting and distilling only 97.24 and 97.23 percent alcohol was found in the distillate. 500 cc of commercial alcohol was now ground about five days with 45 grams of the anhydrous fluoride. After decantation and distillation an alcohol of sp. gr. 0.80481 (96.43 percent) was obtained. To this was then added the alcohol above mentioned (600–800 cc 97.2 percent) with about a liter of the alcohol (97.5 percent) obtained by the boiling and freezing process, and about 240 grams of fluoride. This was ground several days, and on distillation duplicate determinations showed the distillate to have a specific gravity of 0.80167 and 0.80155, showing 97.48 and 97.52 percent by weight of alcohol.

From these determinations we may conclude that the alcohol which is in equilibrium with the mixture of the anhydrous fluoride and the hydrate contains 97.50 percent

alcohol and 2.50 percent water, and that the solution of the salt under these conditions contains 1.52 percent fluoride, 96.05 percent alcohol and 2.43 percent water by weight. This value has been plotted on the curves showing the equilibrium.

To determine the solubility of the fluoride in absolute alcohol, about 200 cc of Merck's absolute alcohol (sp. gr. 0.79527, 99.58 percent by weight) was treated in a stoppered flask with an excess of potassium fluoride which had been freshly ignited and quickly pulverized. The mixture was heated for some time at about its boiling point, with frequent shaking, and then allowed to stand for a couple of weeks at room temperature, with frequent shaking. 28.63 and 36.45 grams of this solution gave, on treatment with concentrated hydrochloric acid, evaporation and ignition, 1.6887 and 2.1416 grams potassium chloride, equivalent to 1.3061 and 1.6690 grams fluoride, or 4.56 and 4.58 percent by weight of potassium fluoride (4.79 grams per 100 grams solvent).

It is noticeable that although the fluoride is very soluble in water (the saturated solution containing 48 percent of the anhydrous salt, or 92.3 grams per 100 grams water),<sup>1</sup> yet the addition of water to the solution in absolute alcohol decreases the solubility to a marked extent; from 4.79 grams per 100 grams solvent at practically 100 percent alcohol, to 1.54 grams per 100 grams solvent in 97.5 percent alcohol, and 1.17 grams per 100 grams solvent in 84 percent alcohol. A similar decrease in solubility with the first increase in water content of the alcohol appears in the case of the fluoride with propyl alcohol, and the carbonate with all three alcohols, but not with sodium chloride and propyl alcohol. It is interesting to note that the solubility of the fluoride in absolute ethyl alcohol is approximately the same as in 60 percent alcohol.

In general, the solubility of a salt in aqueous alcohol decreases as the concentration of the alcohol increases.<sup>2</sup> But

<sup>1</sup> Mylius and Funk: *Ber. chem. Ges. Berlin*, 30, 1716 (1897).

<sup>2</sup> Gérardin: *Ann. Chim. Phys.*, [4] 5, 129 (1865).

L. de Bruyn has shown<sup>1</sup> that in absolute methyl alcohol the hydrated salts  $\text{MgSO}_4 \cdot 7\text{H}_2\text{O}$ ,  $\text{ZnSO}_4 \cdot 7\text{H}_2\text{O}$ ,  $\text{CoSO}_4 \cdot 7\text{H}_2\text{O}$ ,  $\text{NiSO}_4 \cdot 7\text{H}_2\text{O}$ ,  $\text{FeSO}_4 \cdot 7\text{H}_2\text{O}$ ,  $\text{NiSO}_4 \cdot 6\text{H}_2\text{O}$ , and  $\text{CuSO}_4 \cdot 5\text{H}_2\text{O}$ , were readily soluble, but were quickly precipitated again as the lower hydrates (especially on adding a drop of water), or as lower hydrates in which part of the water of crystallization was replaced by alcohol. In 93 percent alcohol they were only slightly soluble, and less so in the more dilute alcohols down to 50 percent. He states that ethyl alcohol shows a similar behavior, but that it is less marked. Bödker<sup>2</sup> found that anhydrous cobalt and copper chlorides were very soluble in absolute alcohol, but that the addition of water caused the immediate precipitation of the hydrate. The results here shown with potassium carbonate and fluoride seem to be somewhat similar in principle, though of an entirely different class of salt, as far as the degree of hydration is concerned. But dilution of the solution of the anhydrous fluoride with water failed to produce precipitation of the hydrate, probably on account of supersaturation phenomena, which were frequently noticed with alcoholic solutions of the hydrate which had been prepared at high temperatures and cooled out of contact with the solid phase. It is particularly noticeable that sodium chloride, which does not form a crystalline hydrate at ordinary temperatures, was least soluble in the strongest propyl alcohol.

Besides the well-known methods for the determination of alcohol by the specific gravity of a solution, and by its boiling point (ebullioscope), many others have been studied in the attempt to find advantageous methods. Oxidation with either bichromate or permanganate has been tried by many.<sup>3</sup>

<sup>1</sup> *Zeit. phys. Chem.*, 10, 782 (1892).

<sup>2</sup> *Ibid.*, 22, 505 (1897).

<sup>3</sup> Thresh: *Chem. News*, 38, 251 (1878); Röse: *Zeit. angew. Chem.*, 1, 31 (1888); Bourcart: *Bull. Soc. Ind. Mulhouse*, 59, 558; *Jour. Chem. Soc.*, 58, 1030 (1890); Frankland and Frew: *Jour. Chem. Soc.*, 59, 93 (1891); Grünhut: *Chem. Zeit.*, 15, 847; *Jour. Chem. Soc.*, 62, 1031 (1892); Benedict and Neudörfer: *Chem. Zeit.*, 16, 77; Kuriloff: *Ber. chem. ges. Berlin*, 30, 741 (1897); Benedict and Norris: *Jour. Am. Chem. Soc.*, 20, 293 (1898); Lassar-Cohn: *Zeit. anal.*

The refractive index of mixtures of alcohol and water offers another method which has been well studied, and appears to be of practical value in some cases.<sup>1</sup> Indirect methods, depending on the change in specific gravity of a liquor after removing alcohol by evaporation and making up again to the same volume, have been discussed by a number of authors.<sup>2</sup> The surface tension of the solution has been used to determine the alcoholic content,<sup>3</sup> as have also the lowering of the freezing point,<sup>4</sup> the solubility of cinchonine in chloroform containing alcohol,<sup>5</sup> the Pasteur drop reaction,<sup>6</sup> and the color produced by cobalt salts in the presence of a sulphocyanate.<sup>7</sup>

More closely allied to the method which I have to propose are the methods of Hager<sup>8</sup> and Böttger<sup>9</sup> who shake out the

---

Chem., 38, 251 (1899); Argenson: Bull. Soc. chim. Paris, [3] 27, 1000 (1902); Pozzi-Escot: Ann. chim. anal., 7, 11 (1902); 9, 126 (1904); Nicloux: Ibid., 9, 214 (1904); Martin: Rev. intern. Falsif., 17, 48 (1904); Jour. Chem. Soc., 86, II, 520 (1904); Janak: Oesterr. Chem. Zeit., [2] 14, 17; Chem. Abs., 5, 2761 (1911).

<sup>1</sup> Riegler: Zeit. anal. Chem., 35, 27 (1896); Ling and Pope: Jour. Fed. Inst. Brewing, 7, 170 (1901); Jour. Chem. Soc., 80, II, 628 (1901); Leach and Lythgoe: Jour. Am. Chem. Soc., 27, 964 (1905); Ackermann and Steinmann: Zeit. ges. Brauw., 20, 259; Chem. Zentr., 1905, II, 1672; Ackermann: Ann. chim. anal., 10, 171 (1905); Kamenetsky: Chem. Zeit., 31, 257; Doroshevskii and Dvorzhanchik: Jour. Russ. Phys. Chem. Soc., 40, 101; 41, 849; Chem. Abs., 2, 2181 (1908); 4, 135, 1403 (1910); Race: Jour. Soc. Chem. Ind., 27, 547 (1908); Andrews: Jour. Am. Chem. Soc., 30, 353 (1908); Frank-Kamenetsky: Zeit. angew. Chem., 23, 293 (1910); Sidersky: Bull. Assoc. Sucr. Dist., 27, 1168; Chem. Abs., 4, 2759 (1910); Ann. chim. anal., 16, 142; Chem. Abs., 5, 2143 (1911).

<sup>2</sup> Blunt: Analyst, 1891, 221; Richmond: Jour. Fed. Inst. Brewing, 2, 529 (1896); Jour. Chem. Soc., 72, 193 (1897); Leonard and Smith: Analyst, 22, 225; Pharm. Zentr., 49, 971; Günzel: Zeit. Nahr. Genussm., 18, 206; Chem. Abs., 3, 2717 (1909); Bonis: Ann. fals., 4, 276; Chem. Abs., 5, 3492 (1911).

<sup>3</sup> Duclaux: Ann. chim. phys., [5] 2, 233 (1874); Gossart: Comptes rendus, 113, 537 (1891).

<sup>4</sup> Gaunt: Zeit. anal. Chem., 44, 106 (1905).

<sup>5</sup> Oudemans: Liebig's Ann., 166, 78 (1873); Jour. Chem. Soc., 26, 533 (1873).

<sup>6</sup> Klöcker: Centr. Bakt. Parasitenk., II Abt., 31, 108; Chem. Abs., 6, 136 (1912).

<sup>7</sup> T. T. Monell: Chem. Zentr., 1877, 24.

<sup>8</sup> Chem. Zentr., 1888, 1512.

<sup>9</sup> Ibid., 1872, 742.

alcohol from essences with glycerine, and measure the increase of volume; Curtis,<sup>1</sup> who titrates alcohol of 85 percent or over with toluene; and Bohlig,<sup>2</sup> who salts out the alcohol with potassium carbonate, and measures the volume of the layer obtained, standardizing the apparatus with known weights of absolute alcohol.

Methods involving the critical temperature of solution of alcohol-water mixtures with other liquids have also been worked out. The method of Crismer,<sup>3</sup> using kerosene, is said to be very accurate, but is only applicable to very strong alcohol, while the method of Buboux and Dutoit,<sup>4</sup> using a mixture of aniline and alcohol, is only suitable for mixtures containing from 8 to 12 percent alcohol. An apparatus for the determination of alcohol, based on the solubility of ether in alcohols of various strengths (*i. e.*, the binodal curve in the system alcohol, ether, water), has been patented and described.<sup>5</sup> As specially pure ether and 98 percent alcohol are used to make the determination, it would hardly seem to be an easy and convenient method, and the accuracy may well be doubted.

If the binodal curve in the system containing a salt and aqueous alcohol has a small enough temperature coefficient, and can be determined with sufficient accuracy, it ought to be possible to add to a liquid of unknown alcoholic content enough of the salt to cause the solution to separate into two layers, and then, by the cautious addition of water, get the solution to be just homogeneous again. Now if the weights used are known, the composition of the original alcohol can be found, since the composition of the solution which we have made homogeneous is represented by that point on the binodal

<sup>1</sup> Jour. Phys. Chem., 2, 371 (1898).

<sup>2</sup> Zeit. anal. Chem., 25, 19 (1893).

<sup>3</sup> Bull. Assoc. belg. des Chimistes, 16, 83; Chem. Zentr., 1902, II, 3.

<sup>4</sup> Ann. chim. anal., 13, 4; see also Duperthuis and Philippe: Mitt. Lebensm. Hyg., 1, 188; Chem. Abs., 5, 3118 (1911).

<sup>5</sup> H. Kapeller: D. R. P., 213, 127; Oesterr. ung. Zeit. Zuckerind. Landw., 38, 817; Chem. Abs., 4, 232, 2348 (1910); Sidersky: Ann. chim. anal. appl., 15, 105; Bull. Assoc. Sucr. Dist., 27, 562; Chem. Abs., 4, 1648, 1793 (1910).



curve which expresses the relation of the amount of salt to the whole solution or to the amount of solvent present. Since, on the line separating the homogeneous from the heterogeneous system, there can only be one solution which contains this proportion of salt, this fixes the composition of the final solution definitely, and the weight of alcohol present can easily be computed.

While Schreinemaker's method for representing such equilibria, as described on a previous page, is convenient and useful in many ways, it is not suitable for determination of the slope of the curve for analytical purposes, as triangular coördinates are inconvenient and the most important part of the curve comes at a point where the figure is very much compressed. For this reason the results in Table 3 have been calculated also on the basis of the weight of each component present in that quantity of the solution which contains 100 grams of the solvent. Since the sum of the weights of water and alcohol here will be 100, this relation can be plotted in rectangular coördinates, the composition of the solvent being shown on one axis, and the amount of salt per 100 grams solvent on the other. Such a curve also represents directly the solubility of the salt in alcohol of all strengths. In Fig. 4 such curves have been plotted for both potassium fluoride and potassium carbonate, and show well the difference between these salts in their behavior towards alcohol. It is noticeable that at concentrations above 30 grams of salt per 100 grams of solvent the curves are nearly identical, although above 50 grams per 100 grams solvent, the solubility of the alcohol in the solution of the carbonate is a little less than that in the solution of the fluoride. It will be noted that the results for the fluoride form a smooth curve with which the individual results are in much better accord than is the case with the carbonate. The end-point seemed to be more definite in the first case, and apparently the effect of temperature is less. For this reason the table recommended has been calculated on the basis of the fluoride curve, and is given in Table 4.

To determine alcohol in an alcoholic liquid with this table, a stoppered flask is weighed, some freshly ignited potassium fluoride is weighed into it, a weighed amount of alcoholic liquid added, and the fluoride dissolved. From the probable alcoholic content of the liquid used, the proportions of liquid and salt are so chosen that there will be salt enough to cause the liquid to separate into two phases; *i. e.*, if a whiskey supposed to contain from 40 to 50 percent alcohol is being tested, the salt should be in the proportion of at least 12 grams per 100 grams whiskey, and then a separation will

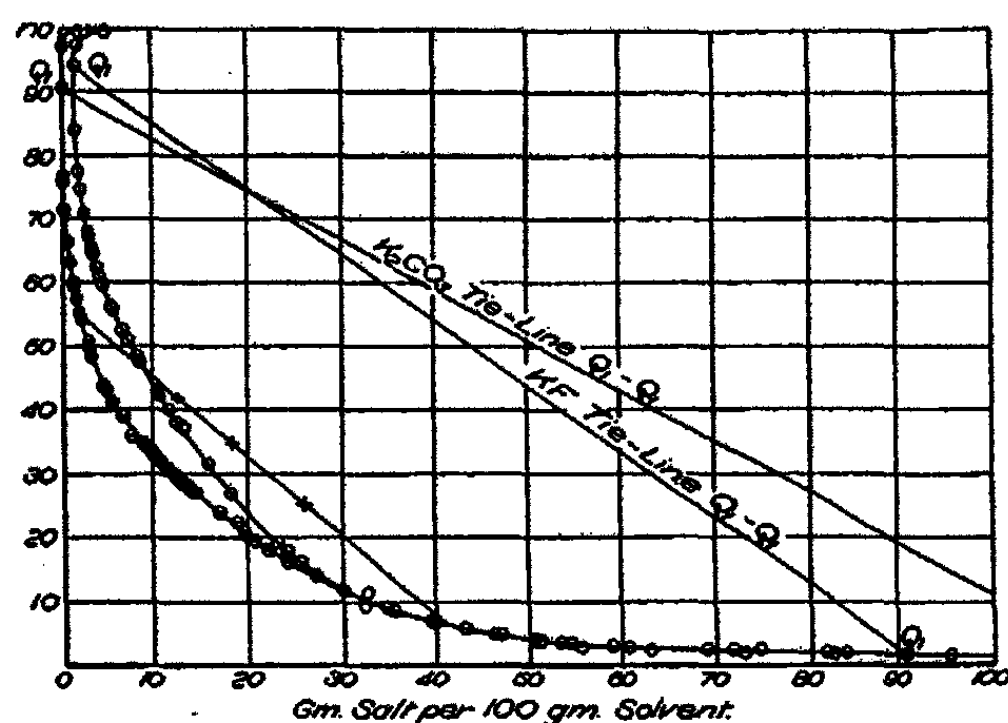

Fig. 4—Equilibria in the Systems: Potassium Fluoride, Ethyl Alcohol, Water; and Potassium Carbonate, Ethyl Alcohol, Water

take place, if the whiskey contains more than 39.4 percent alcohol, as indicated by Table 4. If the solution is now brought to approximately 25°, water added cautiously, with frequent shaking, until the solution just becomes homogeneous, and the whole weighed again, the proportion of the salt present to the total weight of solvent (whiskey plus water) gives, by reference to the table, the percent of alcohol in such total weight of solvent, hence the weight of alcohol in the sample. For rapid work, if 100 grams of the liquid under examination be taken, and all weights carried only to the

TABLE 4—DETERMINATION OF ALCOHOL BY MEANS OF THE BINODAL CURVE OF THE TERNARY SYSTEM: WATER, ALCOHOL, POTASSIUM FLUORIDE

Gm. per 100 gm. solvent			Gm. per 100 gm. solvent		
KF	C <sub>2</sub> H <sub>5</sub> OH	<i>d</i>	KF	C <sub>2</sub> H <sub>5</sub> OH	<i>d</i>
60	2.82	0.10	30	11.36	0.72
59	2.92	0.10	29	12.14	0.78
58	3.02	0.10	28	12.99	0.85
57	3.13	0.11	27	13.92	0.93
56	3.24	0.11	26	14.94	1.02
55	3.36	0.12	25	16.07	1.13
54	3.48	0.12	24	17.33	1.26
53	3.61	0.13	23	18.75	1.42
52	3.75	0.14	22	20.26	1.51
51	3.90	0.15	21	21.80	1.54
50	4.06	0.16	20	23.40	1.60
49	4.23	0.17	19	25.10	1.70
48	4.41	0.18	18	26.90	1.80
47	4.60	0.19	17	28.8	1.9
46	4.80	0.20	16	30.8	2.0
45	5.01	0.21	15	32.9	2.1
44	5.24	0.23	14	35.0	2.1
43	5.48	0.24	13	37.2	2.2
42	5.74	0.26	12	39.4	2.2
41	6.02	0.28	11	41.7	2.3
40	6.32	0.30	10	44.0	2.3
39	6.65	0.33	9	46.4	2.4
38	7.01	0.36	8	49.0	2.6
37	7.40	0.39	7	51.9	2.9
36	7.83	0.43	6	55.1	3.2
35	8.30	0.47	5	58.7	3.6
34	8.81	0.51	4	62.8	4.1
33	9.37	0.56	3	67.5	4.7
32	9.98	0.61	2	78.6	11.1
31	10.64	0.66	—	—	—

nearest tenth of a gram, reasonably accurate results could be secured in a very few minutes. If extreme accuracy is not desired and care is taken in the preservation of the fluoride, it might be used without previous drying, making correction for water held as determined by one or two tests.

It is obvious that the method would not be very accurate

TABLE 5---DETERMINATION OF ETHYL ALCOHOL IN THE PRESENCE OF METHYL ALCOHOL BY ITS SOLUBILITY IN SOLUTIONS OF POTASSIUM FLUORIDE. ROOM TEMPERATURE. MIXTURE USED CONTAINS 85.55 PERCENT C<sub>2</sub>H<sub>5</sub>OH, 6.27 PERCENT CH<sub>3</sub>OH AND 8.17 PERCENT H<sub>2</sub>O BY WEIGHT

Solvent added		Total weight present				Grams per 100 grams solvent				Correct	
Water	Mixture	KF	H <sub>2</sub> O	C <sub>2</sub> H <sub>5</sub> OH	CH <sub>3</sub> OH	KF	H <sub>2</sub> O	C <sub>2</sub> H <sub>5</sub> OH	CH <sub>3</sub> OH	C <sub>2</sub> H <sub>5</sub> OH	d
17.294	0.380	15.500	17.325	0.325	0.024	87.699	98.02	1.84	0.14	1.35	-0.5
13.361	1.500	15.500	30.809	1.608	0.118	47.641	94.70	4.94	0.36	4.48	-0.46
7.363	1.862	15.500	38.324	3.201	0.235	37.117	91.77	7.67	0.56	7.78	0.11
11.849	5.667	15.500	50.636	8.049	0.591	26.149	85.42	13.58	1.00	14.79	1.21
14.083	31.091	15.500	67.260	34.648	2.542	14.840	64.39	33.17	2.43	33.24	0.07
10.618	31.370	15.500	80.442	61.486	4.510	10.585	54.93	41.99	3.08	42.65	0.66
13.031	0.291	10.776	13.055	0.249	0.018	80.889	98.00	1.87	0.14	1.50	-0.37
4.350	0.359	10.776	17.434	0.556	0.041	59.764	96.69	3.08	0.23	2.84	-0.24
2.765	0.391	10.776	20.231	0.891	0.066	50.861	95.49	4.21	0.31	3.93	-0.28
4.078	1.185	10.776	24.406	1.905	0.140	40.741	92.27	7.20	0.53	6.10	-1.10
6.315	1.788	10.776	30.867	3.435	0.252	31.187	89.33	9.94	0.73	10.51	0.73
2.682	1.464	10.776	33.669	4.688	0.344	27.846	87.00	12.11	0.89	13.12	1.01
1.482	2.351	10.776	35.343	6.699	0.491	25.336	83.10	15.75	1.15	15.70	0.05
3.480	5.145	10.776	39.244	11.101	0.814	21.065	76.71	21.70	1.59	21.70	0.0
1.955	3.894	10.776	41.517	14.433	1.058	18.903	72.83	25.32	1.86	25.28	-0.04
2.771	7.428	10.776	44.895	20.788	1.524	16.035	66.80	30.93	2.27	30.73	-0.2
27.377	1.390	15.172	27.491	1.189	0.087	52.741	95.56	4.13	0.30	3.65	-0.48

4.738	0.919	15.172	32.304	1.975	0.145	44.074	93.84	5.74	0.42	5.22	—	0.52
8.850	2.972	15.172	41.397	4.518	0.331	32.807	89.51	9.77	0.72	9.49	—	0.28
1.941	1.108	15.172	43.428	5.466	0.401	30.778	88.10	11.09	0.81	10.84	—	0.25
7.695	6.650	15.172	51.667	11.155	0.818	23.840	81.19	17.53	1.28	17.56	—	0.03
3.086	4.317	15.172	55.106	14.848	1.089	21.356	77.57	20.90	1.53	21.25	—	0.35
2.065 <sup>1</sup>	3.891	15.172	57.476	18.174	1.333	19.708	74.66	23.61	1.73	23.90	—	0.29
2.453	6.597	15.172	60.468	23.818	1.747	17.635	70.29	27.68	2.03	27.6	—	0.08
7.407	19.765	15.172	69.490	40.728	2.987	13.402	61.38	35.98	2.64	36.32	—	0.34
4.166	12.372	15.172	74.667	51.313	3.763	11.694	57.55	39.55	2.90	40.1	—	0.65
4.624	15.500	15.172	80.558	64.574	4.735	10.124	53.75	43.09	3.16	43.81	—	0.72
4.445	15.972	15.172	86.308	78.239	5.737	8.910	50.68	45.95	3.37	46.63	—	0.68
11.638	46.822	15.172	101.773	118.297	8.675	6.633	44.49	51.72	3.79	53.07	—	1.35
— <sup>2</sup>	—	11.001	57.089	43.641	3.201	10.585	54.93	41.99	3.08	—	—	—
7.538	27.354	11.001	66.863	67.043	4.917	7.924	48.16	48.29	3.54	49.22	—	0.93
9.254	44.872	11.001	79.784	105.432	7.732	5.702	41.35	54.64	4.01	56.17	—	1.53

<sup>1</sup> Lost 0.016 gm. on standing after the previous determination.

<sup>2</sup> Part of the solution from the sixth determination.

in the presence of large quantities of dissolved solids, as in the case of a beer. But in the determination of alcohol in liquids where solids are absent, the good agreement of the data plotted in Fig. 4 with the smooth curve indicates that it would be satisfactorily accurate. One determination carried out on alcohol which had a sp. gr. of 0.95233 (33.13 percent by weight) gave 33.18 percent. Heating the solution to 35° caused the solution to cloud a little, and when the titration was completed at that temperature 33.53 percent of alcohol was found. The temperature coefficient for such a solution was evidently negligible within the range to which it would be easy to confine the temperature of the determination.

Since methyl alcohol is not precipitated by potassium fluoride, it was thought interesting to see what effect the presence of a certain amount of methyl alcohol would have on the determination of ethyl alcohol by this method. By weighing out some of the ethyl alcohol previously used, and mixing it with a weighed amount of absolute methyl alcohol, a solution was made containing 85.55 percent ethyl alcohol, 6.27 percent methyl alcohol, and 8.17 percent water by weight. The weight of methyl alcohol was thus 7.33 percent of the weight of absolute ethyl alcohol present. A series of determinations were made with this mixture and potassium fluoride, and the results are recorded in Table 5, and plotted in Fig. 5. In plotting these, the quantity ( $d$ ) chosen to be

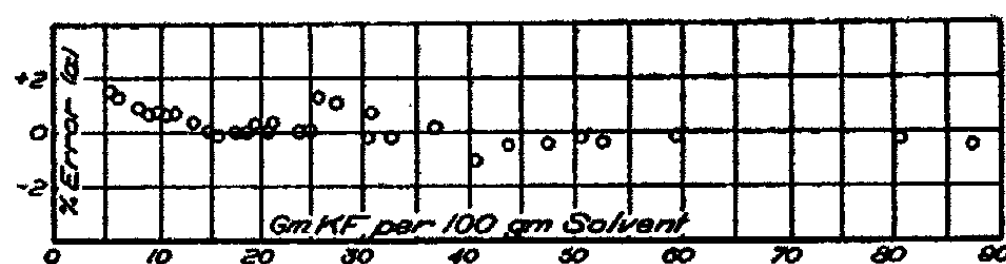

Fig. 5—Determination of Ethyl Alcohol in the Presence of Methyl Alcohol

plotted against the concentration of the salt was the amount by which the percent of ethyl alcohol in the solution was changed; *i. e.*, the error in the determination of the ethyl alcohol caused by the presence of 7.33 percent of its weight

of methyl alcohol. A negative value indicates that too little alcohol would be found, on account of the increase in the solubility of the ethyl alcohol in the potassium fluoride solution, caused by the presence of the methyl alcohol, while a positive value indicates that too high a result would be found, the methyl alcohol here decreasing the solubility of the ethyl alcohol. It is surprising to note that in concentrated solutions there appears first a negative effect, over a wide range, and the methyl alcohol in the mixture acts as a solvent for the ethyl alcohol, then conditions appear to be reversed, although the results are not very concordant. Then between 25 and 15 grams salt per 100 grams solvent, the determination is correct, within the limits of the experimental error, and from this point down, the solubility of the ethyl alcohol is decreased by the methyl alcohol to a constantly increasing extent. This is a phenomenon worthy of a further investigation, but it appears probable that within certain concentrations, ethyl alcohol can be satisfactorily determined in the presence of methyl alcohol by this method.

#### **System Potassium Carbonate, Ethyl Alcohol, Water**

Potassium carbonate is a salt which is more often found in the laboratory than the fluoride, and therefore more convenient for analytical purposes, so this system was studied and the position of the binodal curve determined. This salt was the first ever noted as having the power to salt out alcohol, as it is known that Raymond Lully (1235-1315) used and described it for that purpose. The composition of the solutions formed was first studied by Lescoeur,<sup>1</sup> who determined the composition of the upper layer at the quadruple point. He believed it to be a definite hydrate of alcohol, but he was evidently in error here, as shown by Schreinemakers.<sup>2</sup> A few determinations of points on the binodal curve were made by Linebarger,<sup>3</sup> but the points found all lie within a very

<sup>1</sup> Bull. Soc. chim. Paris, [3] 17, 18 (1897).

<sup>2</sup> Zeit. phys. Chem., 23, 649 (1897).

<sup>3</sup> Am. Chem. Jour., 14, 380 (1892).

narrow range (0.4 to 2.1 grams carbonate per 100 grams solvent) and the method used could not give very accurate results, as shown later, in the system: potassium carbonate, water, methyl alcohol.

B. de Bruyn<sup>1</sup> determined the concentration of the solutions in equilibrium at the quadruple point, at different temperatures. He says of the results, "the salt content of both layers increases with the temperature, the alcohol content changes less than the error of analysis. At 35° I found for alcohol in the upper layer 91.7, 89.8, 90.4, 91.6 percent, in the table I have used the average. Lescoeur found 90.0 percent twice, and 93.5 percent, his figures vary among themselves more than mine, but the average agrees with the results in the table." His determinations nearest room temperature are at 17° and 35°. His alcohol determinations, according to his own statements, leave much to be desired. Bell<sup>2</sup> determined the composition of nine solutions lying on the binodal curve, and recently Cuno<sup>3</sup> determined the composition of eight sets of conjugate solutions. He states<sup>4</sup> that his results agree fairly well with those of Bell, although plotting them together shows that his curve lies above that of Bell for its whole length, the difference in alcohol content between solutions of the same salt content in the two curves being often nearly a percent. His results are the most complete which have been previously published, but his method of alcohol determination (by the conductivity of the solution) might be open to question, as a foundation for an analytical method. He says he did not determine the composition of the solutions at the quadruple point, on account of the difficulty of determining alcohol in such strong and such weak solutions.

As previously stated, some difficulty was experienced at times in getting good end-points with this salt, so a larger number of determinations were made than in the case of the

<sup>1</sup> *Zeit. phys. Chem.*, 32, 63 (1900).

<sup>2</sup> *Jour. Phys. Chem.*, 9, 531 (1905).

<sup>3</sup> *Verh. phys. Ges. Berlin*, 5, 735; *Drude's Ann.*, 25, 346 (1908).

<sup>4</sup> *Drude's Ann.*, 28, 663 (1909).



fluoride. The figures will be found in Table 6, and the complete curve in Fig. 6. This is the first time the complete figure for this system has been shown. The hydrate of the salt has been a matter of much dispute,<sup>1</sup> but the work of Foote and Sholes on the dehydration of alcohol and that of

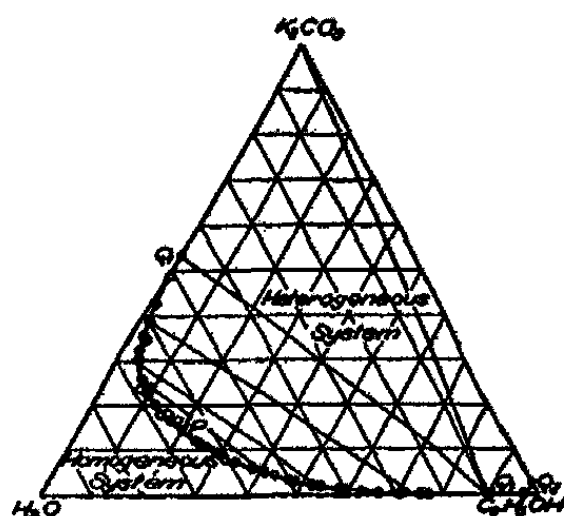

Fig. 6—Equilibrium in the System: Potassium Carbonate, Ethyl Alcohol, Water

de Forcrand<sup>2</sup> show that the hydrate which is stable at ordinary temperature is  $2K_2CO_3 \cdot 3H_2O$ . This has been introduced in the proper place in the diagram, which corresponds to the general one previously described, although the line joining the saturated solution to the lower solution at the quadruple point (DE, Fig. 2) is very short, and the triangle HDE is so small as to be invisible in the figure.

A number of tie-lines were located in an attempt to find the approximate location of the plait-point. They were determined by evaporation of weighed portions of conjugate pairs of solutions, ignition and weighing of the carbonate. By reference to Table 6 it was easy to get the corresponding percents of alcohol and water. The following concentrations of potassium carbonate (in percent of the total weight of the solution) were found to exist in conjugate solutions: 0.241

<sup>1</sup> For discussion of the earlier work see B. de Bruyn; *Zeit. phys. Chem.*, 32, 63 (1900).

<sup>2</sup> *Comptes rendus*, 148, 1731 (1909).

TABLE 6—BINODAL CURVE FOR THE SYSTEM: WATER, ALCOHOL, POTASSIUM CARBONATE, AT ROOM TEMPERATURE. ALCOHOL USED 91.28 PERCENT BY WEIGHT

Solvent added		Total weight present			Grams per 100 gm. solvent			Percent by weight		
Water	Alcohol	K <sub>2</sub> CO <sub>3</sub>	H <sub>2</sub> O	C <sub>2</sub> H <sub>5</sub> OH	K <sub>2</sub> CO <sub>3</sub>	H <sub>2</sub> O	C <sub>2</sub> H <sub>5</sub> OH	K <sub>2</sub> CO <sub>3</sub>	H <sub>2</sub> O	C <sub>2</sub> H <sub>5</sub> OH
26.678	1.228	14.122	26.785	1.121	50.606	95.98	4.02	33.60	63.73	2.67
12.015	4.169	14.122	39.164	4.926	32.030	88.83	11.17	24.26	67.28	8.46
11.518	7.354	14.122	51.323	11.639	22.429	81.51	18.49	18.32	66.58	15.10
6.209	5.429	14.122	58.005	16.595	18.930	77.75	22.25	15.92	65.37	18.71
12.516	11.011	14.122	71.481	26.646	14.392	72.85	27.15	12.58	63.68	23.74
14.296	13.053	14.122	86.915	38.561	11.255	69.27	30.73	10.12	62.26	27.62
11.501	11.788	14.122	99.444	49.321	9.493	66.85	33.15	8.67	61.05	30.28
22.042	22.585	14.122	123.455	69.937	7.302	63.84	36.16	6.81	59.50	33.70
31.754	14.190	6.056	32.991	12.953	13.181	71.81	28.19	11.65	63.45	24.91
4.362	4.460	6.056	37.742	17.024	11.058	68.92	31.08	9.96	62.06	27.98
8.337	9.176	6.056	46.879	25.400	8.379	64.86	35.14	7.73	59.85	32.42
9.258	11.840	6.056	67.169	36.208	6.486	61.22	38.78	6.09	57.49	36.42
8.724	12.149	6.056	66.952	47.298	5.301	58.60	41.40	5.03	55.65	39.32
9.047	13.743	6.056	77.197	59.843	4.419	56.33	43.67	4.23	53.95	41.32
9.825	16.184	6.056	88.433	74.616	3.714	54.24	45.76	3.58	52.30	44.12
16.081	28.920	6.056	107.036	101.014	2.911	51.45	48.55	2.83	49.99	47.18
33.375	0.342	32.096	33.405	0.312	95.192	99.07	0.93	48.77	50.76	0.48
9.873	0.379	32.096	43.311	0.658	72.997	98.50	1.50	42.20	56.94	0.87
6.279	0.488	32.096	49.633	1.103	63.261	97.83	2.17	38.75	59.92	1.33
6.195	0.621	32.096	55.882	1.670	55.769	97.10	2.90	35.80	62.34	1.86
4.599	0.598	32.096	60.533	2.216	51.150	96.47	3.53	33.84	63.82	2.34
5.058	0.902	32.096	65.670	3.039	46.713	95.58	4.42	31.84	65.15	3.01
4.438	1.028	32.096	70.198	3.977	43.271	94.64	5.36	30.20	66.06	3.74
14.260	4.461	32.096	84.847	8.049	34.55	91.34	8.66	25.68	67.89	6.44
9.880	4.700	32.096	95.137	12.339	29.863	88.52	11.48	23.00	68.16	8.84
15.248	8.438	32.096	111.121	20.041	24.470	84.72	15.28	19.66	68.06	12.28
12.939	10.674	32.096	124.991	29.784	20.737	80.76	19.24	17.18	66.89	15.94

4.685	4.037	32.096	130.028	33.469	19.631	79.53	20.47	16.41	66.48	17.11
13.610	12.281	32.096	144.709	44.679	16.947	76.41	23.59	14.49	65.34	20.17
21.024	19.420	32.096	167.426	62.406	13.965	72.85	27.15	12.25	63.92	23.82
17.810	18.154	32.096	186.819	78.977	12.075	70.29	29.71	10.77	62.72	26.51
16.253	16.671	32.096	204.526	94.194	10.745	68.47	31.53	9.70	61.83	28.47
32.504	36.227	32.096	240.189	127.262	8.735	65.37	34.63	8.03	60.12	31.85
80.979	9.210	28.614	81.782	8.407	31.727	90.68	9.32	24.09	68.84	7.07
24.900	16.284	28.614	108.102	23.271	21.781	82.29	17.71	17.89	67.57	14.54
6.513	4.720	28.614	115.027	27.579	20.065	80.66	19.34	16.71	67.18	16.11
13.092	13.194	28.614	129.270	39.622	16.942	76.54	23.46	14.49	65.45	20.06
15.473	14.561	28.614	146.013	32.913	14.384	73.40	26.60	12.58	64.18	23.35
13.313	13.620	28.614	160.514	65.345	12.669	71.07	28.93	11.24	63.08	25.68
12.299	12.505	28.614	173.903	76.760	11.415	69.38	30.62	10.25	62.27	27.48
11.657	12.279	28.614	186.631	87.968	10.420	67.96	32.04	9.44	61.55	29.01
19.167 <sup>1</sup>	21.809	28.614	207.680	107.866	9.068	65.82	34.18	8.31	60.35	31.34
17.522	19.392	28.614	226.893	125.567	8.118	64.37	35.63	7.51	59.63	32.96
(Distillation)										
18.230	17.294	3.2511	—	—	1.635	44.86	55.14	1.61	44.14	54.25
6.755	13.486	1.482	19.738	15.786	4.172	55.56	44.44	4.00	53.33	42.66
7.026	15.714	1.482	27.669	28.096	2.658	49.62	50.38	2.58	48.34	49.08
6.487	17.075	1.482	36.065	42.440	1.888	45.94	54.06	1.85	45.09	53.06
10.642 <sup>2</sup>	31.460	1.482	44.041	58.026	1.452	43.15	56.85	1.43	42.53	56.04
15.105	51.219	1.482	57.410	86.721	1.028	39.83	60.17	1.02	39.42	59.56
12.959	24.290	0.393	76.981	133.474	0.704	36.58	63.42	0.70	36.32	62.98
3.745	13.760	0.393	15.077	22.172	1.055	40.48	59.52	1.04	40.06	58.90
4.547	18.282	0.393	20.022	34.732	0.718	36.57	63.43	0.71	36.31	62.98
6.497	41.333	0.393	26.163	51.420	0.507	33.72	66.28	0.50	33.55	65.95
5.230	57.624	0.393	36.264	89.149	0.313	28.92	71.08	0.31	28.83	70.86
2.553	29.489	0.393	46.519	141.748	0.209	24.71	75.29	0.21	24.66	75.13
84.488 <sup>3</sup>	0.417	93.260	51.643	168.666	0.178	23.44	76.56	0.18	23.40	76.42
24.584 <sup>3</sup>	0.931	93.260	84.488	0.417	109.840	99.51	0.49	52.34	47.42	0.23
44.523	3.159	93.260	109.072	1.348	84.459	98.78	1.22	45.79	53.55	0.66
			153.870	4.232	58.987	97.32	2.68	37.10	61.21	1.69

<sup>1</sup> Loss on standing 0.29 gram.<sup>2</sup> Loss on standing 0.38 gram.<sup>3</sup> Absolute alcohol was used in these two determinations.

and 39.11, 1.72 and 29.62, 4.03 and 25.7, 6.30 and 21.08, 8.29 and 19.15, 10.35 and 18.18. As previously noticed, the tie-lines are, in the triangular system, the straight lines joining the points representing the conjugate solutions. By calculation from the composition of two known conjugate solutions, it is easy to determine the composition of a mixture which will separate into given volumes of each of the two solutions. Such a calculation for the second set of conjugate solutions above recorded is plotted with the binodal curve in rectangular coordinates in Fig. 4. The computations were for the volume relations 1 : 1, 2 : 1, and 1 : 2, and as will be seen, they lie on the straight line joining the two conjugate solutions. Thus the tie-lines are straight lines in this system of representation also.

Two determinations of the alcoholic content of the upper solution at the quadruple point ( $Q_1$ , Fig. 6) were made by allowing a mixture of alcohol, strong carbonate solution, and the hydrate to stand several weeks, with repeated shaking, and then pouring off the upper layer, distilling to dryness, and determining the specific gravity of the distillate. Two different solutions thus prepared gave distillates with specific gravities of 0.82104 and 0.82093 at 15.55/15.55°, indicating that they contained, respectively, 90.63 and 90.67 percent alcohol. Three determinations of the carbonate content gave 0.0953, 0.0869 and 0.1022 gram per 100 grams solvent, giving an average composition for the upper layer of alcohol 90.65, water 9.35 and potassium carbonate 0.095 gram per 100 grams solvent, or 90.56, 9.34, and 0.09 percent by weight, respectively. The average of the results of de Bruyn at 17° is 91.5 percent alcohol and 0.06 percent carbonate, and at 35°, 90.9 percent alcohol and 0.07 percent carbonate. Since his alcohol determinations at 35° ranged from 89.8 to 91.7 percent, and those at 17° were presumably not more accurate, the agreement is as close as could be expected. For the lower layer, duplicate determinations gave 53.30 and 52.88 percent carbonate and 0.273 and 0.283 percent alcohol. The alcohol determination was made on 600 to 800 grams of the solution,

it being easy to get off all the alcohol in the first 50 cc of the distillate, as shown by the boiling point of the solution, and in this the alcohol is easily determined. B. de Bruyn<sup>1</sup> found at 35°, 53.4 percent carbonate and 0.2 percent alcohol, at 17° 52.1 percent carbonate and 0.2 percent alcohol. It will be noted that the alcohol has not reduced the solubility of the salt appreciably, as the saturated aqueous solution contained 53.06 percent carbonate. With methyl alcohol, which is more soluble in the strong carbonate solution, the solubility is markedly decreased.

The solubility of the salt in 97.5 percent and in absolute alcohol, was determined as in the case of the fluoride, and saturated solutions at room temperature were found to contain (a) 0.0524, (b) 0.0564 and (a) 1.62 (b) 1.64 percent of carbonate, respectively, or an average of 0.054 percent for 97.5 percent alcohol and 1.63 percent for 99.6 percent alcohol. The same increase in solubility in the anhydrous alcohol is here to be noticed, as in the case of the fluoride. As the mixture of the anhydrous salt and the hydrate is in equilibrium with 99.6 percent alcohol,<sup>2</sup> this is the other quadruple point, Q<sub>2</sub>.

In Table 7 will be found the approximate values of the solubility of ethyl alcohol, corrected from the curve in Fig. 4, over the range in which the curve is quite definitely determined. These values may be used for the determination of alcohol in the same manner as those in Table 4, using potassium carbonate which has been ignited, and is free from insoluble impurities, but the use of the fluoride appears to give more accurate results.

In Fig. 4 the curves for both the fluoride and the carbonate are plotted, and the two quadruple-point tie-lines drawn. The determinations marked with a circle having a diameter drawn in are in the carbonate system, and it will be noticed that a number of them lie quite a distance from the

<sup>1</sup> *Zeit. phys. Chem.*, 32, 64 (1900).

<sup>2</sup> Foote and Sholes: *Jour. Am. Chem. Soc.*, 33, 1309 (1911).

line. The cause was the uncertainty in the end-point, due to suspended matter which obscures the disappearance of the emulsion. If the carbonate is to be used for the analytical method, it should be freed from such matter by solution in its own weight of water, filtration and evaporation. All weights given in the above and other tables refer to the anhydrous salt. Where a large number of determinations were to be made, a standard solution, containing 50 percent of the anhydrous salt by weight, could easily be used, and allowance made for its water content. A crystal of solid phenolphthalein is the best indicator.

TABLE 7

Gm. per 100 gm. solvent			Gm. per 100 gm. solvent		
K <sub>2</sub> CO <sub>3</sub>	C <sub>2</sub> H <sub>5</sub> OH	<i>d</i>	K <sub>2</sub> CO <sub>3</sub>	C <sub>2</sub> H <sub>5</sub> OH	<i>d</i>
45	5.0	0.2	22	17.8	1.0
44	5.2	0.2	21	18.9	1.1
43	5.4	0.2	20	20.0	1.1
42	5.7	0.3	19	21.1	1.1
41	6.0	0.3	18	22.3	1.2
40	6.3	0.3	17	23.5	1.2
39	6.6	0.3	16	24.7	1.2
38	7.0	0.4	15	26.0	1.3
37	7.4	0.4	14	27.2	1.2
36	7.8	0.4	13	28.5	1.3
35	8.3	0.5	12	29.8	1.3
34	8.8	0.5	11	31.1	1.3
33	9.3	0.5	10	32.5	1.4
32	9.9	0.6	9	34.0	1.5
31	10.5	0.6	8	35.7	1.7
30	11.2	0.7	7	37.5	1.8
29	11.8	0.6	6	39.6	2.1
28	12.5	0.7	5	42.0	2.4
27	13.2	0.7	4	44.7	2.7
26	14.0	0.8	3	48.3	3.6
25	14.9	0.9	2.5	50.3	2.0
24	15.8	0.9	2	52.6	2.6
23	16.8	1.0	—	—	—

The curve and the table above given may be considered approximately correct for room temperature (23° to 26°).

The effect of change of temperature was studied a little, and will be discussed under a later head (Temperature Coefficients and Critical Solution Temperatures).

#### System Potassium Carbonate, Methyl Alcohol, Water

This system was first investigated by Linebarger,<sup>1</sup> who made three determinations of points on the binodal curve. As shown in Fig. 7, his results are evidently far from accurate,

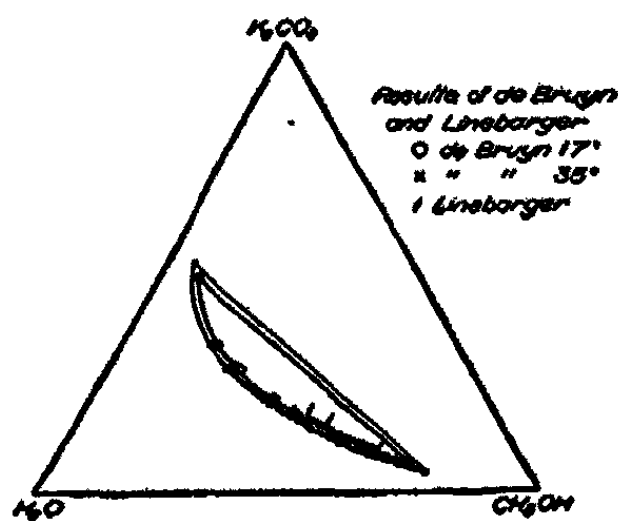

Fig. 7—Plot of Results of B. de Bruyn and Linebarger, in the System: Potassium Carbonate, Methyl Alcohol, Water

as they lie on a curve which must be true for temperatures near zero. De Bruyn<sup>2</sup> determined the position of the quadruple point at 17° and 35°, three other tie-lines on the binodal curve at the first temperature and two at the second. He recalculated Linebarger's results and showed their inaccuracy, and gave a general ("schematisch") curve to show the form of the isotherm. This is reproduced in Fig. 8, to compare with the diagram of the isotherm which I have determined at room temperature (Fig. 9) and the plot of the actual results obtained by him and by Linebarger (Fig. 7). The only other work which appears to have been done on this system is that of Wrewsky,<sup>3</sup> who showed that the vapor

<sup>1</sup> Am. Chem. Jour., 14, 380 (1892).

<sup>2</sup> Zeit. phys. Chem., 32, 63 (1900).

<sup>3</sup> Jour. Russ. Phys. Chem. Soc., 32, 593 (1900); Jour. Chem. Soc., 80, 11, 56 (1901).

pressure of the system increased with the proportion of the salt present. He showed that, as was to be expected, the two layers formed in the system had the same vapor pressure, the partial pressure of the water being lowered and that of the alcohol raised by the presence of the salt. He also studied the effect of temperature on the vapor pressure of the system.

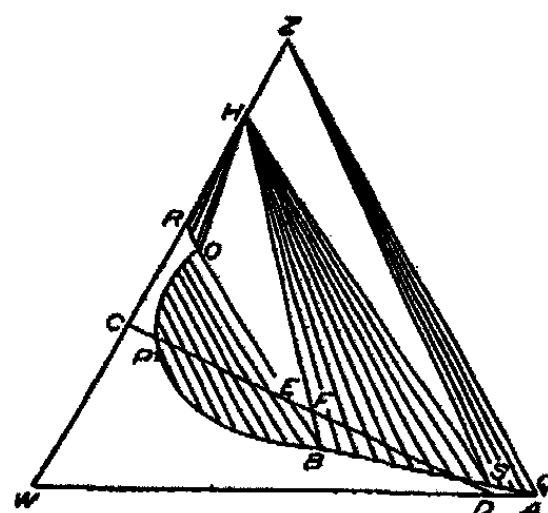

Fig. 8—B. de Bruyn's Diagram for the System: Potassium Carbonate, Methyl Alcohol, Water

As potassium carbonate appears to be the only salt which is capable of precipitating methyl alcohol at ordinary temperatures, this system was studied to see how closely it resembled the others. The binodal curve was determined, as in the other cases, and the data are found in Table 8. Determinations of the composition of the two layers in equilibrium at the quadruple point were made by the same methods as in the other cases. The upper solution was found to contain 76.22 and 75.48 percent of methyl alcohol and 6.38, 6.22, and 6.36 percent potassium carbonate, or an average of 75.85 percent methyl alcohol and 6.32 percent carbonate. Much trouble was experienced in distilling this solution, on account of the very violent bumping which took place, and the distillate had to be redistilled once or twice to get rid of all carbonate. The determinations on the lower solution showed 6.10 percent of methyl alcohol and 49.01 and 49.09 percent of carbonate.



A number of determinations of the solubility of the carbonate in stronger alcohol were made by weighing out quantities of the absolute alcohol and water to make a solution of known composition, adding a slight excess of the finely powdered anhydrous salt, shaking, sometimes warming, and allowing to stand for some weeks at room temperature, with frequent shaking. If the excess of carbonate appeared to be becoming less than a gram, more was added. From 80 to 160 grams of the solvent were used in each case. With stronger alcohol, the time required to reach equilibrium was longer. Thus using alcohol of 86.7, 90.5 and 96.5 percent by weight, determinations after three weeks gave potassium carbonate 2.03, 1.38, and 1.84 percent by weight of the respective solutions, while after five weeks the same solutions gave 2.05, 1.56 and 2.13 percent by weight. The higher figure was accepted in the first two cases as approximately correct, and another solution made up for the latter. This solution, using 96.2 percent alcohol, was digested for several hours at 40°-50°, and after standing two weeks, with frequent shaking and occasional warming, showed in two duplicate determinations 2.72 and 2.72 percent by weight. A sample of the absolute alcohol, similarly treated, gave a solution containing 4.29 percent by weight of the carbonate, the two duplicate determinations agreeing exactly. But on longer standing and addition of more carbonate, the salt content rose to 5.54 and 5.74 percent. In the course of the determination of the upper quadruple point (anhydrous salt, hydrate, liquid, vapor) the alcohol and salt content of two solutions was determined by analysis. One contained 90.96 percent alcohol and 1.98 percent salt by weight, and the other 94.74 percent alcohol and 4.39 percent salt (93.67 and 98.91 grams alcohol per 100 grams solvent, respectively).

The determination of this upper quadruple point by dehydration of about 90 percent methyl alcohol by successive treatments with the ignited and pulverized carbonate, showed that at that point the solvent is 99.35 percent alcohol and the solution contains 94.14 percent alcohol, 0.33 percent water,

TABLE 8—BINODAL CURVE FOR THE SYSTEM: WATER, METHYL ALCOHOL, POTASSIUM CARBONATE, AT ROOM TEMPERATURE. ABSOLUTE METHYL ALCOHOL USED

Water	Solvent added			Total weight present			Grams per 100 gm. solvent			Percent by weight		
	CH <sub>3</sub> OH	K <sub>2</sub> CO <sub>3</sub>	H <sub>2</sub> O	CH <sub>3</sub> OH	H <sub>2</sub> O	K <sub>2</sub> CO <sub>3</sub>	CH <sub>3</sub> OH	H <sub>2</sub> O	K <sub>2</sub> CO <sub>3</sub>	CH <sub>3</sub> OH	H <sub>2</sub> O	K <sub>2</sub> CO <sub>3</sub>
45.997	8.504	37.327	45.997	8.504	84.40	68.489	15.60	84.40	40.65	50.09	9.26	
11.425	12.757	37.327	57.422	21.261	72.98	47.440	27.02	72.98	32.18	49.50	18.33	
5.935	10.210	37.327	63.357	31.471	66.81	39.363	33.19	66.81	28.25	47.94	23.82	
14.308	26.276	37.327	77.665	57.747	57.35	27.566	42.65	57.35	21.61	44.96	33.43	
8.020	16.879	37.327	85.685	74.626	53.45	23.284	46.55	53.45	18.89	43.36	37.76	
8.895	19.944	37.327	94.580	94.570	50.00	19.734	50.00	50.00	16.48	41.76	41.76	
9.764	23.979	37.327	104.344	118.549	46.81	16.747	53.19	46.81	14.34	40.10	45.56	
13.487	36.455	37.327	117.831	155.004	43.19	13.681	56.81	43.19	12.03	37.99	49.97	
11.839	38.198	37.327	129.670	193.202	40.16	11.561	59.84	40.16	10.17	35.33	52.64	
5.917	26.851	37.327	135.587	220.053	38.12	10.496	61.88	38.12	9.23	33.53	54.43	
24.008	3.404	21.496	24.008	3.404	87.58	78.418	12.42	87.58	43.95	49.09	6.96	
8.311	7.871	21.496	32.519	11.275	74.25	49.084	25.75	74.25	32.92	49.80	17.27	
9.964	17.844	21.496	42.483	29.119	59.33	30.122	40.67	59.33	23.15	45.60	31.26	
7.905	16.257	21.496	50.388	45.376	52.62	22.447	47.38	52.62	18.33	42.97	38.69	
10.019	23.678	21.496	60.407	69.054	46.66	16.604	53.34	46.66	14.24	40.02	45.74	
4.531	12.922	21.496	64.938	81.976	44.20	14.632	55.80	44.20	12.55	37.91	47.85	
7.578	22.652	21.496	72.516	104.628	40.94	12.135	59.06	40.94	10.82	36.51	52.67	
14.550	53.276	21.496	87.066	157.904	35.54	8.775	64.46	35.54	8.07	32.67	59.26	
6.228	38.591	21.496	93.294	196.495	32.19	7.418	67.81	32.19	6.91	29.97	63.13	
85.754 <sup>1</sup>	1.860	92.611	85.754	1.860	97.88	105.703	2.12	97.88	51.39	47.58	1.03	
1.548 <sup>1</sup>	2.229	92.611	87.302	4.089	95.53	101.335	4.47	95.53	50.33	47.45	2.22	
8.939	8.877	92.611	96.241	12.966	88.13	84.803	11.87	88.13	45.89	47.69	6.42	
50.596	49.054	92.611	146.837	62.020	70.31	44.341	29.69	70.31	30.72	48.71	20.57	
(Part of above)	57.907	57.907	91.815	38.778	70.31	44.341	29.69	70.31	30.72	48.71	20.57	
6.255	11.340	57.907	98.070	50.118	66.18	39.077	33.82	66.18	28.10	47.59	24.32	

<sup>1</sup> These two points are not on the binodal curve, but are on the curve of saturated carbonate solutions not saturated with alcohol.

and 5.53 percent potassium carbonate by weight. These determinations have been plotted in the proper places in the figure. A determination made by the distillation of an alcoholic solution, and determination of both alcohol and carbonate is also plotted. (Carbonate 4.41, water 20.76 and alcohol 74.83 percent by weight of the solution.)

Since the lower or watery layer at the quadruple point  $Q_1$  contains 6.1 percent of alcohol and only 49.05 percent carbonate, while the saturated solution of the carbonate, prepared from the same salt and standing at room temperature with an excess of the hydrate, contained 53.06 percent of the salt, attempts were made to get determinations showing points on the line DE (Fig. 2), and the two determinations marked with a star in Table 8 were the result. They were made by the same general method as the other

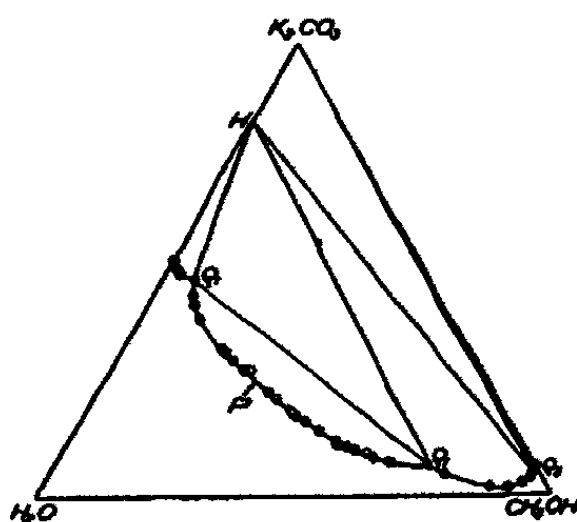

Fig. 9—Equilibrium in the System: Potassium Carbonate, Methyl Alcohol, Water

determinations in the table, except that the solution was not saturated with alcohol, only a small amount being added, and then water cautiously added, with shaking and standing, until the precipitated carbonate was just redissolved. As this point could not be determined with very great accuracy, the results are only approximate, but care was taken to get them as accurate as possible. They have been plotted in Fig. 9.

**System Potassium Fluoride, Propyl Alcohol, Water**

The binodal curve was determined at room temperature as in the other systems, and the results are found in Table 9 and plotted in Figs. 10 and 13. Experiments showed that the influence of temperature on the position of the binodal curve was quite marked in all cases in which propyl alcohol was one of the components of the system. Therefore some observations on the effect of such changes at several points in the curve were made, and are discussed under a later heading (Temperature Coefficients and Critical Solution Temperatures). Determinations of the composition of the two

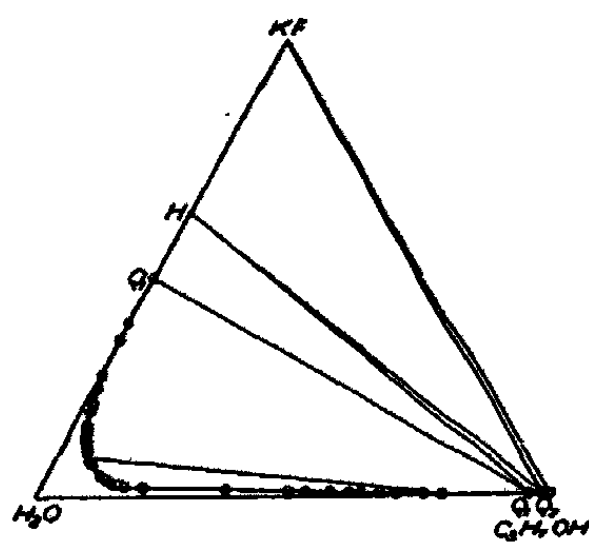

Fig. 10—Equilibrium in the System: Potassium Fluoride, Normal Propyl Alcohol, Water

liquid layers in equilibrium at the quadruple point were made as in the other systems, and the lower solution was found to contain 47.62 percent potassium fluoride and 0.039 percent propyl alcohol by weight, or 90.91 and 0.075 gram per 100 grams solvent, respectively. The upper solution contained 96.78 percent propyl alcohol and 0.17 percent potassium fluoride by weight, or 96.98 and 0.17 gram per 100 grams solvent, respectively. A determination of the solubility of potassium fluoride in 99.6 percent propyl alcohol, using about 45 grams of the solution, showed that the saturated solution at room temperature contained 0.34 percent of the anhydrous fluoride. One tie-line was investigated, the upper solution

by analysis containing 78.91 percent of the alcohol and 0.31 percent fluoride by weight, while the lower solution contained 9.67 percent fluoride by weight. This tie-line has been drawn on Fig. 10.

A determination of the composition of the liquid layer at the second quadruple point, where the liquid is in equilibrium with both the solid salt and its hydrate, was made with the original alcohol, and the distillate was found to be 98.72 percent by weight propyl alcohol. Later another determination was made, using some of the propyl alcohol recovered and fractionated as described on page 417, and diluted with water. After digesting with an excess of fluoride the distillate contained 98.77 and 98.73 percent of alcohol by weight. The solution was found to contain 0.28 percent by weight of the anhydrous fluoride, and its composition was thus: propyl alcohol 98.44 percent, potassium fluoride 0.28 percent, water 1.28 percent by weight. The close agreement of the two determinations made on the recovered and purified alcohol with the one made with the original alcohol, indicates that the influence of the impurities in the latter was negligible.

**System Potassium Carbonate, Propyl Alcohol, Water**

The determinations of points on the binodal curve were made as in the other systems, and are found in Table 10, and plotted in Figs. 11 and 13. The temperature of the solutions

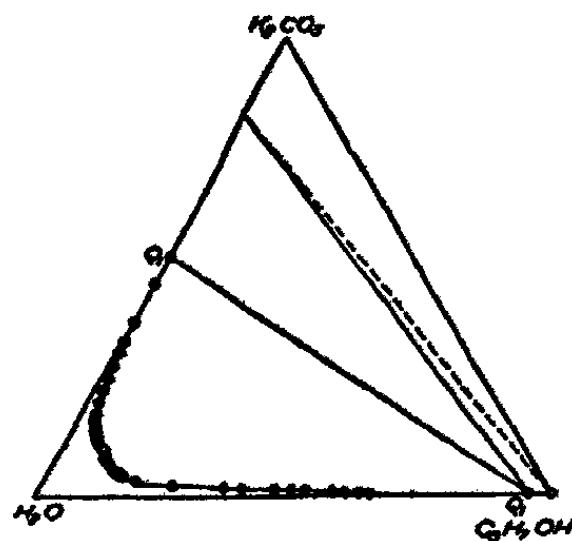

Fig. 11—Equilibrium in the System: Potassium Carbonate, Normal Propyl Alcohol, Water

TABLE 9—BINODAL CURVE FOR THE SYSTEM: WATER, PROPYL ALCOHOL, POTASSIUM FLUORIDE, AT ROOM TEMPERATURE. 86.77 PERCENT ALCOHOL USED IN FIRST TWO SERIES, 98.05 PERCENT IN THE REST

Solvent added	Total weight present				Grams per 100 gm. solvent				Percent by weight			
	C <sub>3</sub> H <sub>7</sub> OH	H <sub>2</sub> O	KF	C <sub>3</sub> H <sub>7</sub> OH	H <sub>2</sub> O	KF	C <sub>3</sub> H <sub>7</sub> OH	H <sub>2</sub> O	KF	H <sub>2</sub> O	KF	C <sub>3</sub> H <sub>7</sub> OH
Water												
81.992	0.956	82.118	28.891	0.830	34.830	99.00	1.00	25.83	73.43	0.74		
11.242	0.481	93.424	28.891	1.247	30.517	98.68	1.32	23.38	75.61	1.01		
7.692	0.477	101.179	28.891	1.661	28.093	93.38	1.62	21.93	76.80	1.26		
16.289	1.123	117.616	28.891	2.636	24.025	97.81	2.19	19.37	78.86	1.77		
4.593	0.322	122.252	28.891	2.915	23.082	97.67	2.33	18.75	79.35	1.89		
13.514	1.249	135.932	28.891	3.998	20.647	97.14	2.86	17.11	80.52	2.37		
14.112	1.401	150.226	28.891	5.217	18.586	96.64	3.36	15.67	81.49	2.83		
17.346	2.082	167.844	28.891	7.027	16.521	95.98	4.02	14.18	82.37	3.45		
9.462	1.056	177.446	28.891	7.943	15.584	95.72	4.28	13.48	82.81	3.70		
19.632	2.804	197.444	28.891	10.381	13.902	95.00	5.00	12.21	83.41	4.39		
18.869	2.715	216.673	28.891	12.736	12.594	94.45	5.55	11.19	83.89	4.93		
23.355	3.759	240.527	28.891	15.996	11.262	93.76	6.24	10.12	84.27	5.61		
15.218	0.159	15.240	5.736	0.137	37.303	99.11	0.89	27.17	72.18	0.65		
4.063	0.188	19.328	5.736	0.300	29.224	98.47	1.53	22.62	76.20	1.18		
3.754	0.231	23.112	5.736	0.501	24.292	97.88	2.12	19.54	78.75	1.71		
8.190	0.864	31.416	5.736	1.251	17.559	96.17	3.83	14.94	81.81	3.26		
4.101	0.543	35.589	5.736	1.722	15.374	95.38	4.62	13.33	82.67	4.00		
12.350	1.963	48.199	5.736	3.425	11.111	93.37	6.63	10.00	84.03	5.97		
5.920 <sup>1</sup>	1.091	54.241	5.736	4.370	9.787	92.54	7.46	8.91	84.29	6.80		
5.004	1.034	59.382	5.736	5.267	8.873	91.85	8.15	8.15	84.36	7.49		
22.201	4.931	82.235	5.736	9.546	6.250	89.60	10.40	5.88	84.33	9.79		
4.073	1.105	86.454	5.736	10.505	5.916	89.17	10.83	5.59	84.19	10.22		

4.020	1.119	5.736	90.622	11.476	5.618	88.76	11.24	5.32	84.04	10.64
10.944	3.112	5.736	101.978	14.176	4.938	87.80	12.20	4.71	83.67	11.62
13.259	4.006	5.736	115.767	17.652	4.299	86.77	13.23	4.12	83.19	12.69
13.831	5.334	5.746	130.303	22.281	3.759	85.40	14.60	3.62	82.30	14.07
17.434	7.202	5.736	148.690	28.530	3.237	83.90	16.10	3.14	81.27	15.59
29.250	17.561	5.736	180.263	43.768	2.560	80.46	19.54	2.50	78.45	19.05
46.619	0.124	29.873	46.621	0.122	63.908	99.74	0.26	38.99	60.85	0.16
7.734	0.073	29.873	54.356	0.194	54.762	99.64	0.36	35.38	64.38	0.23
83.016	3.506	29.873	137.440	3.632	21.175	97.43	2.57	17.47	80.40	2.12
15.696	2.054	0.909	15.736	2.014	5.121	88.65	11.35	4.87	84.33	10.80
30.588	24.849	1.315	46.809	26.378	1.797	63.96	36.04	1.77	62.83	35.40
5.067	22.512	1.315	52.315	48.451	1.305	51.92	48.08	1.29	51.25	47.46
2.582	10.721	1.315	55.106	58.963	1.153	48.31	51.69	1.14	47.76	51.10
4.255	20.316	1.315	59.757	78.883	0.948	43.10	56.90	0.94	42.70	56.36
3.335	18.504	1.315	63.453	97.026	0.819	39.54	60.46	0.81	39.22	59.97
2.413	14.205	1.315	66.143	110.954	0.743	37.35	62.65	0.74	37.07	62.19
(Part of above)		0.548	27.541	46.197	0.743	37.35	62.65	0.74	37.07	62.19
1.589	12.919	0.548	29.382	58.864	0.621	33.30	66.70	0.62	33.09	66.29
1.713	14.047	0.548	31.366	72.640	0.527	30.16	69.84	0.52	30.00	69.47
3.225	36.306	0.548	35.299	108.238	0.382	24.59	75.41	0.38	24.50	75.12
(Distillation)		—	—	—	0.310	20.34	79.66	0.31	21.19	78.91

<sup>1</sup> Loss on standing 0.024 gram.

TABLE I. EQUILIBRIUM DATA FOR ETHYL ALCOHOL-WATER SYSTEM

TABLE 10—BINODAL CURVE FOR SYSTEM: WATER, PROPYL ALCOHOL, POTASSIUM CARBONATE, AT ROOM TEMPERATURE, 98.05 PERCENT PROPYL ALCOHOL USED

Solvent added		Total weight present			Grams per 100 gm. solvent			Percent by weight		
Water	Alcohol	K <sub>2</sub> CO <sub>3</sub>	H <sub>2</sub> O	C <sub>3</sub> H <sub>7</sub> OH	K <sub>2</sub> CO <sub>3</sub>	H <sub>2</sub> O	C <sub>3</sub> H <sub>7</sub> OH	K <sub>2</sub> CO <sub>3</sub>	H <sub>2</sub> O	C <sub>3</sub> H <sub>7</sub> OH
28.588	0.065	25.387	28.589	0.064	88.602	99.78	0.22	46.98	52.91	0.12
10.990	0.063	25.387	39.580	0.126	63.937	99.68	0.32	39.00	60.80	0.20
8.246	0.067	25.387	47.827	0.192	52.869	99.60	0.40	34.58	65.15	0.26
3.697	0.079	25.387	51.526	0.269	49.014	99.48	0.52	32.89	66.76	0.35
6.136	0.103	25.387	57.664	0.370	43.745	99.36	0.64	30.43	69.12	0.45
6.085	0.159	25.387	63.752	0.526	39.496	99.18	0.82	28.31	71.10	0.59
5.864	0.225	25.387	69.620	0.747	36.078	98.94	1.06	26.51	72.71	0.78
5.524	0.235	25.387	74.149	0.977	33.349	98.72	1.28	25.01	74.03	0.96
9.286	0.503	25.387	84.445	1.470	29.544	98.29	1.71	22.81	75.87	1.32
9.500	0.708	25.387	93.759	2.164	26.466	97.74	2.26	20.93	77.29	1.79
10.833	0.926	25.387	104.611	3.071	23.576	97.15	2.85	19.08	78.62	2.31
10.789 <sup>1</sup>	1.015	25.387	115.395	4.065	21.251	96.60	3.40	17.53	79.67	2.80
9.479	0.993	25.387	124.894	5.038	19.539	96.12	3.88	16.35	80.41	3.24
9.920	1.039	25.387	134.834	6.057	18.019	95.70	4.30	15.27	81.09	3.64
9.491	1.059	25.387	144.346	7.095	16.764	95.32	4.68	14.36	81.63	4.01
10.416	1.243	25.387	154.786	8.314	15.565	94.90	5.10	13.47	82.12	4.41
7.552	1.046	25.387	162.359	9.339	14.786	94.50	5.44	12.88	82.38	4.74
15.407	2.165	25.387	177.808	11.462	13.413	93.94	6.06	11.83	82.83	5.34
(Part of above)		10.593	74.191	4.786	13.413	93.94	6.06	11.83	82.83	5.34
5.583	1.250	10.593	79.798	6.012	12.345	92.99	7.01	10.99	82.77	6.24
10.665	2.071	10.593	90.503	8.043	10.749	91.84	8.16	9.71	82.93	7.37
12.445	2.298	10.593	102.993	10.296	9.350	90.91	9.09	8.55	83.14	8.31



15.301	2.984	10.593	118.352	13.222	8.051	89.95	10.05	7.45	83.25	9.30
28.767	6.540	10.593	147.247	19.634	6.348	88.23	11.77	5.97	82.96	11.07
22.963	1.193	3.986	22.986	1.170	16.501	95.16	4.84	14.16	81.68	4.15
6.953	1.045	3.986	29.959	2.195	12.397	93.17	6.83	11.03	82.89	6.08
11.429	2.059	3.986	41.428	4.214	8.733	90.77	9.23	8.03	83.49	8.49
9.889	2.142	3.986	51.359	6.314	6.911	89.05	10.95	6.46	83.29	10.24
9.429	2.275	3.986	60.832	8.545	5.745	87.68	12.32	5.43	82.92	11.65
8.694	2.210	3.986	69.569	10.712	4.905	86.66	13.34	4.73	82.56	12.71
7.671 <sup>2</sup>	2.217	3.986	77.267	12.881	4.422	85.71	14.29	4.23	82.08	13.68
6.919	2.252	3.986	84.230	15.089	4.013	84.81	15.19	3.86	81.54	14.60
17.689	7.022	3.986	102.056	21.974	3.214	82.28	17.72	3.11	79.71	17.17
17.495	19.055	3.986	119.923	40.657	2.482	74.68	25.32	2.42	72.87	24.71
8.533	13.177	3.986	128.713	53.577	2.187	70.61	29.39	2.14	69.10	28.76
2.889	19.706	3.986	131.986	72.899	1.945	64.42	35.58	1.91	63.19	34.90
5.891	18.412	3.986	138.236	90.952	1.739	60.32	39.68	1.71	59.29	39.00
(Part of above)		1.463	50.759	33.391	1.739	60.32	39.68	1.71	59.29	39.00
7.092	16.872	1.463	58.180	49.934	1.353	53.81	46.19	1.33	53.09	45.57
7.287	14.163	1.463	65.743	63.821	1.129	50.74	49.26	1.116	50.17	48.71
7.154	15.950	1.463	73.208	79.460	0.958	47.95	52.05	0.948	47.49	51.56
(Part of above)		0.464	23.211	25.193	0.958	47.95	52.05	0.948	47.49	51.56
5.454	14.017	0.464	28.938	38.937	0.684	42.63	57.37	0.679	42.34	56.98
3.797	10.543	0.464	32.940	49.275	0.564	40.07	59.93	0.561	39.85	59.59
4.606	13.986	0.464	37.819	62.988	0.460	37.52	62.48	0.457	37.35	62.19
4.399	14.334	0.464	42.498	77.042	0.388	35.55	64.45	0.387	35.41	64.20

<sup>1</sup> Loss on standing 0.026 gram.

<sup>2</sup> Loss on standing 0.021 gram.

was frequently tested during each series of determinations, and kept between 22 and 26°. Some determinations of the effect of change of temperature on the position of the binodal curve were made, and are discussed later. Duplicate determinations of the amount of carbonate in the lower solution at the quadruple point gave 53.05 and 52.89 percent, or practically the same as in saturated solutions of the carbonate at room temperature (53.06 percent). A determination of the propyl alcohol content, in the distillate from about 300 grams of the solution, showed this to be only 0.02 percent by weight. The upper solution contained 0.017 percent by weight of the carbonate, and 95.83 percent of propyl alcohol. It will be noted that as in the case of the quadruple point determinations with ethyl alcohol, the upper layer in the system containing potassium carbonate is a weaker alcohol than in the system containing the fluoride. This indicates, as previously shown, that the saturated solution of the fluoride has a lower vapor tension than that of the carbonate. Determination of the solubility of the anhydrous carbonate in 99.6 percent propyl alcohol showed that the saturated solution under ordinary conditions contained 0.031 percent of the salt. The fluoride is therefore ten times as soluble as the carbonate both in absolute propyl alcohol, and at their respective quadruple points.

The other quadruple point, where there are two solid phases, a liquid and a gaseous phase, was not determined, as from the known vapor pressure of the hydrate of the salt, this point would undoubtedly lie within a few tenths of a percent of 100 percent alcohol, and unless a quantity of specially pure alcohol was available, so that the actual gravity of the absolutely pure alcohol, carefully dried, could be obtained, it would be a waste of time to attempt the determination of this point.

#### **System Sodium Chloride, Propyl Alcohol, Water**

As an example of a salt only moderately soluble in water, not capable of crystallizing with water of crystallization, and

possessing obviously a low affinity for water, sodium chloride was chosen as the precipitant to compare with potassium carbonate and fluoride. The binodal curve was determined as in the other systems, and the determinations are found in Table 11, and plotted in Figs. 12 and 13. The first three

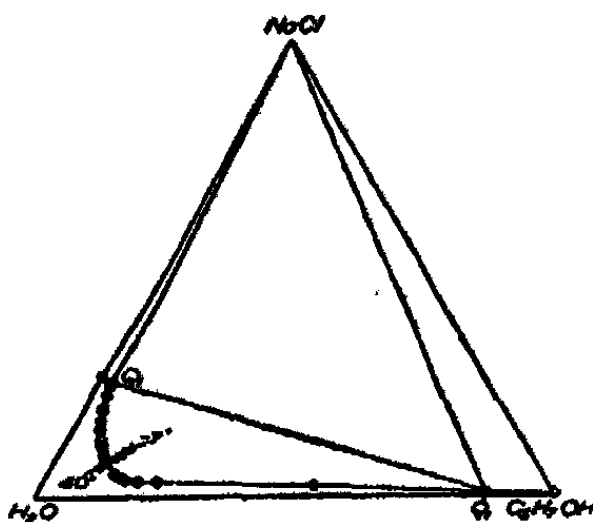

Fig. 12—Equilibrium in the System: Sodium Chloride, Normal Propyl Alcohol, Water

series of determinations were made at room temperature, but without taking special care to control this factor. In the last series, containing the solutions high in alcohol, where the temperature would exert an influence that might be very disturbing, it was determined frequently, and kept between 23° and 25°. The fact that those determinations in this series which fall within the limits of concentration covered by the two series check well with them, would indicate that the temperature in these series was not seriously different from that assumed (23° to 26°). As we do not have in the case of sodium chloride the relatively large heat of dilution which is found with the other two salts, the only factor tending to raise the temperature unduly was the heat of the hands, and the effect seems to have been negligible.

Determinations of the effect of temperature on the equilibrium showed that this is a much greater factor than in the case of the other two salts. This will be discussed in detail under the next head.

TABLE I—BINODAL CURVE FOR SYSTEM: SODIUM CHLORIDE, PROPYL ALCOHOL, WATER, AT ROOM TEMPERATURE. 98.05 PERCENT PROPYL ALCOHOL USED

Solvent added		Total weight present			Grams per 100 gm. solvent			Percent by weight		
Water	Alcohol	NaCl	H <sub>2</sub> O	C <sub>3</sub> H <sub>7</sub> OH	NaCl	H <sub>2</sub> O	C <sub>3</sub> H <sub>7</sub> OH	NaCl	H <sub>2</sub> O	C <sub>3</sub> H <sub>7</sub> OH
33.790	1.200	10.258	33.813	1.177	29.317	96.64	3.36	22.67	74.72	2.60
6.161	0.620	10.258	39.986	1.785	24.558	95.73	4.27	19.72	76.86	3.43
7.259	0.892	10.258	47.262	2.660	20.548	94.67	5.33	17.05	78.53	4.42
8.690	1.220	10.258	55.976	3.856	17.145	93.56	6.44	14.64	79.87	5.50
8.818	1.467	10.258	64.823	5.294	14.630	92.45	7.55	12.76	80.65	6.58
6.995	1.219	10.258	71.842	6.489	13.096	91.72	8.28	11.58	81.10	7.32
10.747	1.942	10.258	82.627	8.393	11.270	90.78	9.22	10.13	81.59	8.29
10.461	2.263	10.258	93.132	10.612	9.888	89.77	10.23	9.00	81.69	9.31
20.378	0.813	5.529	20.394	0.797	26.091	96.24	3.76	20.69	76.33	2.98
3.982	0.439	5.529	24.385	1.227	21.589	95.21	4.79	17.76	78.30	3.94
8.667	1.172	5.529	33.075	2.376	15.596	93.30	6.70	13.49	80.71	5.80
8.913	1.383	5.529	42.015	3.732	12.086	91.84	8.16	10.78	81.94	7.28
61.778	1.828	20.636	61.814	1.792	32.443	97.18	2.82	24.50	73.37	2.13
7.425	0.656	20.636	69.252	2.435	28.786	96.60	3.40	22.35	75.01	2.64
9.318	0.931	20.636	78.588	3.348	25.186	95.91	4.09	20.12	76.61	3.27
10.504	1.052	20.636	89.113	4.379	22.072	95.32	4.68	18.08	78.09	3.83
10.549	1.284	20.636	99.687	5.638	19.593	94.65	5.35	16.38	79.14	4.47
6.671	1.221	20.636	106.382	6.835	18.227	93.96	6.04	15.42	79.47	5.11
9.445	1.231	20.636	115.851	8.042	16.656	93.51	6.49	14.28	80.16	5.56
8.847	1.218	20.636	124.722	9.236	15.405	93.11	6.89	13.35	80.68	5.97
13.476	2.036	20.636	138.238	11.232	13.806	92.49	7.51	12.13	81.27	6.60
10.895	1.839	20.636	149.169	13.035	12.722	91.96	8.04	11.29	81.58	7.13

9.878	1.962	20.636	159.085	14.959	11.857	91.41	8.59	10.60	81.72	7.68
25.455	4.246	20.636	184.623	19.122	10.128	90.61	9.39	9.20	82.28	8.52
25.046	1.345	5.606	25.072	1.319	21.242	95.00	5.00	17.52	78.36	4.12
6.186	0.797	5.606	31.274	2.100	16.797	93.71	6.29	14.38	80.23	5.39
6.022	0.936	5.606	37.314	3.018	13.900	92.52	7.48	12.20	81.23	6.57
6.333	1.164	5.606	43.670	4.159	11.721	91.30	8.70	10.49	81.72	7.79
6.630	1.084	5.606	50.321	5.222	10.093	90.60	9.40	9.17	82.29	8.54
7.124	1.418	5.606	57.473	6.612	8.748	89.68	10.32	8.04	82.47	9.49
9.762	2.307	5.606	67.280	8.874	7.361	88.35	11.65	6.86	82.29	10.85
9.194	2.396	5.606	76.521	11.223	6.389	87.21	12.79	5.95	81.23	11.91
10.611	2.405	5.606	87.179	13.581	5.563	86.52	13.48	5.27	81.96	12.77
10.003 <sup>1</sup>	2.541	5.606	97.154	16.060 <sup>2</sup>	4.952	85.81	14.19	4.72	81.76	13.52
8.512	2.340	5.606	105.712	18.354	4.519	85.21	14.79	4.32	81.53	14.15
10.978	2.917	5.606	116.747	21.214	4.063	84.62	15.38	3.90	81.32	14.78
2.275	2.809	5.606	119.077	23.968	3.919	83.24	16.76	3.77	80.10	16.13
2.941	6.100	5.606	122.137	29.949	3.686	80.31	19.69	3.55	77.46	18.99
0.889 <sup>2</sup>	112.002	6.042	125.210	139.767	2.280	47.25	52.75	2.23	46.20	51.57

<sup>1</sup> Loss on standing 0.090 gram.<sup>2</sup> During this determination it was necessary to add 0.436 gram of salt in order to cause separation into two liquid phases, as the addition of the alcohol alone, even in large quantities, did not cause separation. Temperature of this determination 23°.

There is only one quadruple point in this system, as the salt is not capable of forming a hydrate at ordinary temperatures, and there can therefore be but one solid phase. The composition of the two liquid layers at this point was determined as in the other similar cases. Three determinations of the propyl alcohol content of the lower layer showed 2.29, 2.95 and 2.21 percent, respectively. Determinations of the salt content gave 24.81 and 25.00 percent as against a content of 26.33 percent of salt in the saturated solution in pure water under the same conditions. Duplicate determinations on the upper layer gave 87.81 and 87.59 percent alcohol, and 0.53 and 0.56 percent salt by weight, or 88.28 and 88.08 grams alcohol per 100 grams solvent. A determination of the composition of a saturated solution of salt in 99.6 percent propyl alcohol, showed that it contained 0.040 percent of salt by weight. In this case the solubility decreases continuously with the increase in strength of the alcohol.

Two determinations on the line (DE, Fig. 2) joining the saturated solution of the salt in water with the lower solution at the quadruple point have been made by Armstrong and Eyre,<sup>1</sup> in the course of their work on the displacement of salts from solution by various precipitants. Their salt was a little more soluble in water than mine (36.295 grams per 100 grams water, forming a solution containing 26.63 percent salt), but the difference is so small as to be invisible on the plot, so their results have been marked with crosses on Fig. 12. They found that one solution saturated with salt, contained one-fourth gram molecule propyl alcohol per 1,000 grams water and 355.75 grams salt, while another contained one-half gram molecule of propyl alcohol per 1,000 grams water and 350.20 grams salt. These two solutions would then have the composition: propyl alcohol 1.09 and 2.17 percent, water 72.95 and 72.45 percent, sodium chloride 25.95 and 25.37 percent, respectively, and are plotted in Fig. 12.

Parts of the binodal curves for the three systems involving

<sup>1</sup> Proc. Roy. Soc., 84A, 123 (1910).

propyl alcohol have been drawn in rectangular coördinates in Fig. 13. It will be noticed that the curves are in general

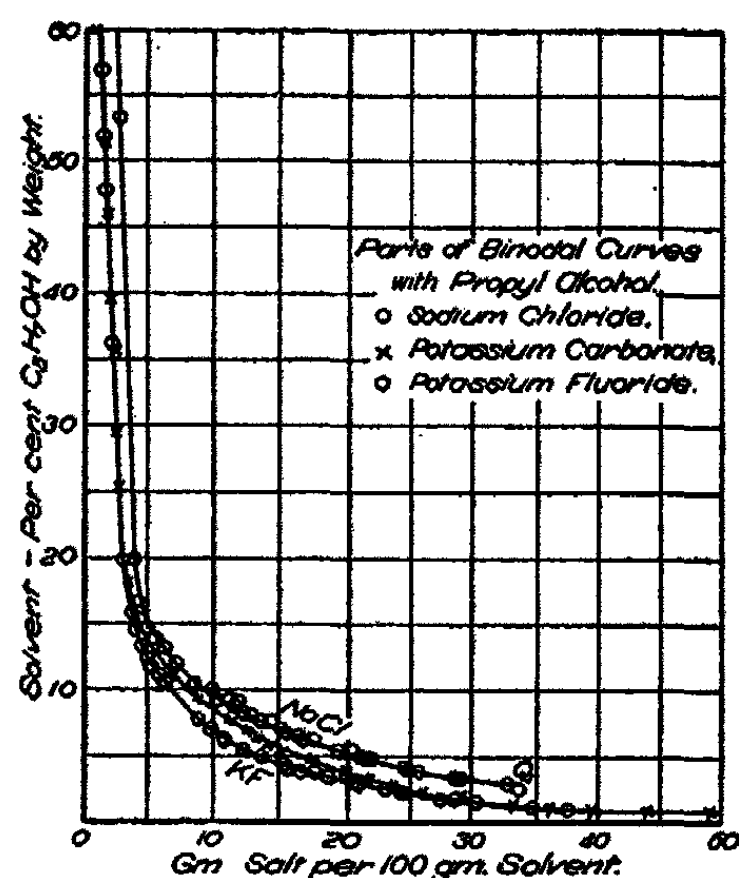

Fig. 13—Parts of Binodal Curve for Normal Propyl Alcohol, and Water, with Sodium Chloride, Potassium Carbonate, or Potassium Fluoride

parallel, but the curve for the carbonate lies above that for the fluoride at concentrations from 3 to 40 grams of salt per 100 grams solvent, and below it for concentrations outside these limits. This is exactly the reverse of things shown in the systems involving ethyl alcohol (Fig. 4), and would indicate that the relative salting-out power of different salts depends to a certain extent upon the substance treated, and not, as some authors have stated, entirely upon the anion and cation of the salt. The fact that sodium chloride, which is here shown to be almost as good a salting-out reagent as potassium carbonate, for propyl alcohol, does not salt out ethyl alcohol at all, although it is relatively insoluble in the strong alcohol, is another indication that we cannot reason from a few isolated cases to form a general theory of the salting-out process.

**Temperature Coefficients and Critical Solution Temperatures**

By the critical solution temperature of a mixture, we understand that temperature at which the solution just becomes homogeneous. We may then distinguish between upper and lower critical temperatures. An upper critical solution temperature is found when on warming an inhomogeneous mixture complete miscibility is obtained at and above a certain temperature, while a lower critical temperature is one below which the solution is homogeneous, but above which it separates into two layers. For ternary systems, the general theory of the critical solubility temperatures has been given by Timmermans.<sup>1</sup> He considers that all liquid pairs have both an upper and a lower critical solution temperature. Above the former and below the latter temperatures they are miscible. Many examples of liquid pairs having upper critical temperatures are known, and some that have lower critical temperatures. But in the case that only one of these temperatures is experimentally realizable for a given pair, it is probable that the other lies either above the boiling point or below the freezing point of the mixture. By the addition of certain substances, very soluble in both components, it was possible in some cases to raise the lower critical temperature and lower the upper one so that both became realizable.

For the case of two solutions which are miscible in all proportions at all temperatures, Timmermans assumes that the lower critical solution temperature lies above the upper critical solution temperature, and therefore there can be no temperature above the lower critical temperature which is at the same time below the upper critical temperature, and *vice versa*. For this reason such liquids are miscible at all temperatures. However, these liquid pairs should actually have such critical temperatures, which might be realized, if we could add some substance, soluble in only one of the liquids, which would lower the lower critical solution tem-

---

<sup>1</sup> *Zeit. phys. Chem.*, 58, 129 (1907).



perature or raise the upper one, or both. Such a substance would cause a separation of the homogeneous mixture into two liquid phases, *i. e.*, would "salt out" the liquid.<sup>1</sup> The systems described herein belong to this class. It seemed, therefore, interesting to study the effect of change of temperature on some of them, and a few experiments along this line were performed, and will be described here.

It is to be noticed that the theoretical requirement that the salting-out substance be insoluble in one of the liquids appears to refer only to a relative solubility, since in the systems involving methyl and ethyl alcohol, the salting-out substances here studied are certainly soluble, and in the case of methyl alcohol and potassium carbonate, this solubility reaches a value of over 6 grams per 100 grams solvent in the absolute alcohol. If the statement in the theory be amended to read that the substance capable of salting out a liquid must have only a slight solubility in mixtures containing a large proportion of that liquid, it would be in better accord with the facts.

For the system: potassium carbonate, ethyl alcohol, water, Cuno<sup>1</sup> has shown that the different isotherms representing the binodal curve all cross at or near the plait-point, and that this point would then be independent of the temperature, and a solution at this point would not cloud (become inhomogeneous) on either warming or cooling. Solutions containing more alcohol than this critical solution will cloud on cooling but remain clear on heating (*i. e.*, are at their upper critical temperature), while those with less alcohol cloud on warming but remain clear on cooling (showing them to be at their lower critical temperature). This idea as to the plait-point is supported by the observations of Krug and McElroy,<sup>2</sup> who studied the precipitation of acetone by the sugars, and state that the isotherms in the system; acetone, dextrose, water, all cross each other in one point. The ob-

<sup>1</sup> Drude's Ann., 25, 346 (1908).

<sup>2</sup> Jour. anal. appl. Chem., 6, 153, 188 (1892).

servations of Traube and Neuberg,<sup>1</sup> in the system: ammonium sulphate, ethyl alcohol, water, also bear out the statement. They state that warming the lower one of two conjugate solutions always causes it to separate, but cooling it does not. With the upper layer these results are reversed. This corresponds exactly with the case of the carbonate.

But Cuno also found that in the case of solutions with less alcohol than that at the plait-point, when some of them were heated to a higher temperature they cleared again, so exhibiting both upper and lower critical temperatures. Thus with a solution containing 35.19 percent of carbonate by weight, the solution was inhomogeneous between the temperatures 25° and 42°, while another solution containing 32.85 percent of the salt was inhomogeneous between 25° and 51°. A solution with 21.16 percent salt was clear below 25°, but cloudy from that point up to 80°, which was as high as it could be tested. Therefore, with increasing salt content, in the upper layer the temperature interval between the upper and lower critical temperatures for a given solution decreases, as does also the alcohol content of the solution. Snell<sup>2</sup> showed that a solution containing 16.8 percent carbonate, 16.8 percent alcohol, and 66.4 percent water had a lower critical solution temperature of 40° and an upper one of 70°. This is very close to the plait-point as given by Cuno (30 grams alcohol, 22.5 grams carbonate, and 100 grams water, or 14.75 percent carbonate), and would tend to throw doubt on the latter's statement that the isotherms all cross at the plait-point. These determinations have been plotted in Fig. 14, the two temperatures at which the solution just clears being joined. The plait-point is also indicated, and the apparent locus of the upper critical temperature for solutions having a lower critical temperature of 25°.

At the close of the third series of determinations in Table 6, the solution (containing 8.03 percent carbonate, and there-

<sup>1</sup> *Zeit. phys. Chem.*, 1, 509 (1887).

<sup>2</sup> *Jour. Phys. Chem.*, 2, 457 (1898).

fore one of the upper layers of a pair of conjugate solutions) was found to have an upper critical temperature of 24.8°. It was now cooled and water added until clear. This solution, having the composition 8.625 grams potassium carbonate, 65.81 grams water and 34.19 grams alcohol per 100 grams solvent, had an upper critical temperature of 13.6°. On

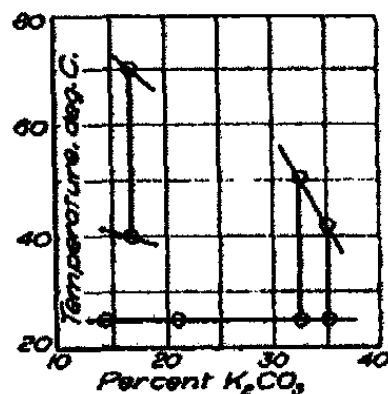

Fig. 14—Upper and Lower Critical Temperatures in the System, Potassium Carbonate, Ethyl Alcohol, Water

cooling more, and adding water to clear, a solution having an upper critical temperature of 7.6° was obtained. It contained 8.554 grams carbonate, 66.13 grams water, and 33.87 grams alcohol per 100 grams solvent. These two points lie on the isotherms for those temperatures. In Fig. 15 the

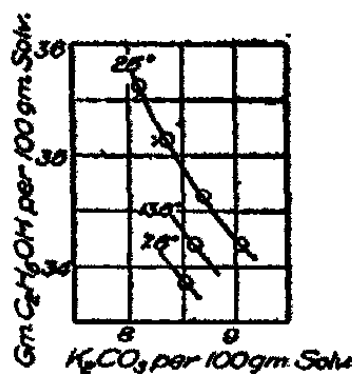

Fig. 15—Isotherms in the System: Potassium Carbonate, Ethyl Alcohol, Water

isotherm for 25° at that concentration has been plotted from the results in Table 6, and these two results put in and the general course of their isotherms at that concentration sketched.

In the system: potassium fluoride, ethyl alcohol, water,

no work has previously been done. In preliminary work here, several solutions which were just homogeneous were both heated and cooled without noticeable separation into two layers. The only quantitative work thus far done along this line on the system was in connection with the determination of alcohol mentioned on page 434, where, at a fluoride concentration of 15.805 grams per 100 grams solvent, a lower critical temperature was shown, and the solution clouded slightly on heating. The amount of solvent present (about 46 grams) was so small that no very accurate determination of the effect of temperature was possible, but as near as could be told, the addition of 0.25 cc water restored the solution to homogeneity at 35°. The effect of a change of temperature on the binodal curve appears to be small.

In the system: potassium carbonate, methyl alcohol, water, B. de Bruyn,<sup>1</sup> by determining the location of the quadruple point  $Q_1$  (solid, two liquids, vapor) at various temperatures, has concluded that as the temperature is lowered, the composition of the two liquid layers at the quadruple point becomes more nearly alike, until at about  $-35^\circ$  they become identical, and hence below this temperature the mixture can contain but one liquid phase, *i. e.*, this is the lower limit of the lower critical solution temperature. He has determined the isotherms in this system for several temperatures, and does not find that they cross at all. From his results for the quadruple points, such isotherms would have to cross each other twice, if they crossed at all. It therefore appears that it is not necessary that the plait-point have this peculiar property in all cases.

We took some of the upper solution at the critical point in this system, and verified qualitatively de Bruyn's results. Cooling this solution caused no separation, but on heating it clouded at 24.5°. Addition of a small amount of an aqueous solution of potassium carbonate having the same percent of carbonate as this solution, raised the point of clouding to about 36°. On heating to higher temperatures, the solution cleared

<sup>1</sup> *Zeit. phys. Chem.*, 32, 63 (1900).

up a good deal, becoming almost clear at 68°, where it was about to boil. In the heating and cooling of this solution the phenomenon of the supersaturation of the upper layer was frequently observed, and it could be supercooled a couple of degrees before the separation took place, if the cooling was rapidly done. A further addition of a little of the same aqueous carbonate solution caused the solution to remain clear even when heated to 62°.

The three systems involving propyl alcohol appear never to have been studied before, and it was here that the effect of temperature appeared to be the greatest. In the system: potassium fluoride, propyl alcohol, water, at the close of the third series (Table 9) the solution was cooled below zero, and no cloudiness appeared. Propyl alcohol was now added, a little at a time, and a solution formed having the composition: potassium fluoride 21.003, water 96.65 and propyl alcohol 3.35 grams per 100 grams solvent, and a lower critical temperature of -3° C. Thus with practically no change in salt content (from 21.175 to 21.003 grams per 100 grams solvent) the drop of 28.6° in temperature increased the solubility of the alcohol from 2.57 to 3.35 grams per 100 grams solvent. On warming, over 10 grams of water had to be added to the solution (containing about 140 grams solvent) to make the solution homogeneous, and this solution (fluoride 19.554, water 96.88 and propyl alcohol 3.12 grams per 100 grams solvent) had a lower critical temperature of 14°. As in the case investigated by B. de Bruyn, and mentioned above; the lower the temperature the greater the apparent effect on the position of the curve. This was well shown by the fact that upon now heating this solution only about 7 cc of water needed to be added to give a solution (fluoride 18.693, water 97.02 and propyl alcohol 2.98 grams per 100 grams solvent) which had a lower critical solution temperature of 43.5°. In Fig. 16, part of the isotherm for 25° (approximately) has been plotted from the data in Table 9, and the points thus determined marked and the position of their isotherms indicated.

In the same system, with a solution much richer in alcohol (fluoride 0.533, water 29.93 and propyl alcohol 70.07 grams per 100 grams solvent) a lower critical solution temperature of 27° and an upper one of 41.5° could be clearly found. Supercooling and superheating gave much trouble in this determination. The separation into two phases between the temperature mentioned was very noticeable.

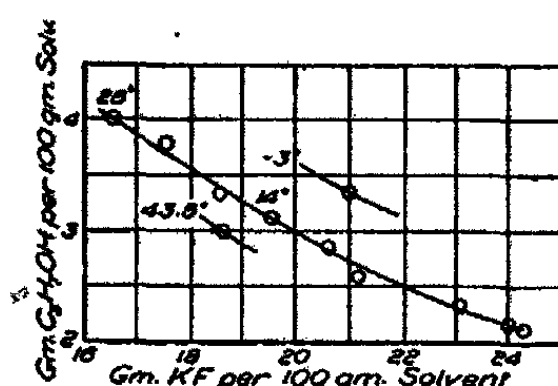

Fig. 16—Isotherms in the System: Potassium Fluoride, Normal Propyl Alcohol, Water

In the system: potassium carbonate, propyl alcohol, water, an attempt was made to determine the effect of temperature changes on the solubility of the alcohol in solutions having a constant salt content. That portion (about 105 grams) of the solution left at the end of the fourth series of determinations in Table 10, and not used in the last series, was used in these determinations. It contained, as noted in Table 10, 0.958 gram potassium carbonate, 47.95 grams water, and 52.05 grams propyl alcohol per 100 grams solvent. It had a lower critical temperature of 27.0° and an upper critical temperature of 57.3°. An aqueous solution was prepared, of the same carbonate content as this solution. About 0.5 gram of this aqueous solution was now added to the alcoholic solution. The salt content, of course, remained unchanged, the composition of the solvent was now: water 48.28 percent, alcohol 51.72 percent, and the critical solution temperatures 34.5° and 50.9°. By accident, a little more of the water solution than was intended was now added (1.218 grams) and the solvent in the resulting solution had the composition:

water 48.87 and alcohol 51.13 percent. On heating and cooling, the solution appeared to be homogeneous except for a trace of cloudiness noticed between 40° and 45°.

More carbonate, in the form of a solution of known strength, was now added, and the solution cooled to about -12° C, remaining cloudy all the time after the carbonate was added. Water at room temperature was added in small portions, and of course warmed the solution somewhat at each addition; after which it was again cooled. The purpose was to get a solution having a lower critical point at as low a temperature as possible, and take a series of critical temperatures, by adding small portions of water. During the addition of one portion of water, it was noticed that a part of the solution cleared up, but clouded again on cooling.

Suspecting the presence of a critical temperature, when further cooling did not clear this, it was allowed to warm up a little, when it was found to clear sharply at exactly -10°. Cooling below this produced copious cloudiness, and just at this point it would clear sharply. Careful observation failed to show any trace of crystallization or precipitation of a solid phase, the solution had the same appearance as at other times when at a critical solution temperature. This appeared to be then an upper critical solution temperature, at -10°. On warming this solution carefully to 60°, no other cloudiness was noticed at any time. After weighing at 25°, some of the 98 percent propyl alcohol was cautiously added until the solution just became cloudy. Over 18 grams was required, showing that the solution which had shown an upper critical point at -10° was far from being saturated at ordinary temperatures. As a matter of fact this solution had a composition of: carbonate 1.405 grams, water 59.60 grams, and alcohol 40.40 grams per 100 grams solvent, whereas from the results in Table 10 it is seen that a solution on the binodal curve at room temperature, having that salt concentration, would have had about 45 percent alcohol in the solvent. These and other results in this system are plotted in Fig. 17.

After the addition of the alcohol, as above-mentioned,

the solution contained 1.237 grams carbonate, 52.43 grams water and 47.57 grams alcohol per 100 grams solvent, and showed a lower critical temperature of 23.5°; *i. e.*, it cleared on cooling to that temperature, and remained clear below it. Curious to see if another upper critical solution temperature would appear below this lower critical temperature, we cooled it to -10°, when the solution again became suddenly inhomogeneous, and the presence of an upper critical solution temperature could be plainly demonstrated at the same point as in the preceding case. After checking this point, the solu-

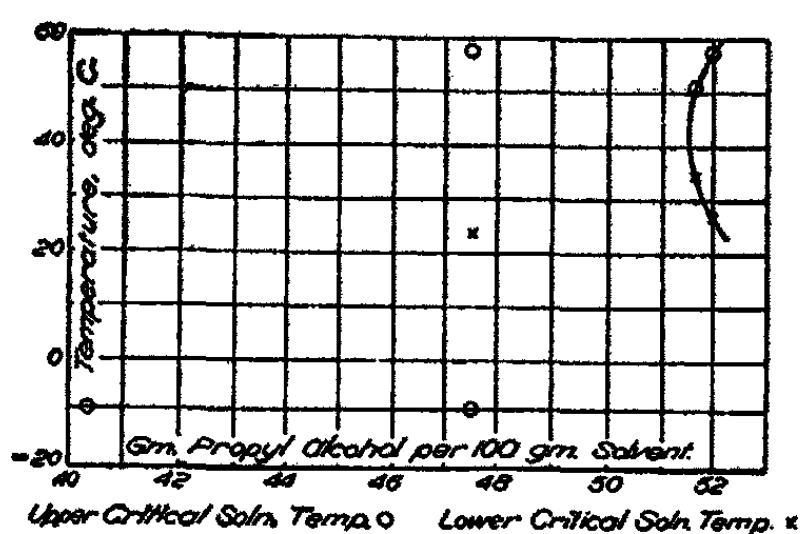

Fig. 17—Upper and Lower Critical Solution Temperatures in the System: Potassium Carbonate, Normal Propyl Alcohol, Water

tion was heated past the lower critical temperature, and another upper critical temperature found at 57.6°. On account of lack of material of known purity these experiments were not continued, but it appears that it is possible to have not only both an upper and a lower critical temperature in the same ternary mixture, as demanded by the theory of Timmermans, but also a second upper critical temperature which lies below the lower critical temperature, and does not appear to have been previously considered possible. It may have been caused by impurities in the alcohol, but that does not seem probable, and the phenomenon will be further investigated.

The effect of temperature upon the equilibrium in the case of propyl alcohol and sodium chloride is the largest of



any of those here studied. At the close of the third series of determinations (Table 11) the solution had a lower critical temperature of 23°. It was cooled and more alcohol added to saturate the solution at the lower temperature. Thus the same amount of salt (20.636 grams) and water (184.539 grams) which at 23° dissolved 19.113 grams of absolute propyl alcohol was now able to dissolve 10.155 grams more of the 98 percent alcohol, and the solution had a lower critical temperature of -7°. By warming the solution and adding successive portions of water, solutions were obtained having lower critical solution temperatures of 4.0°, 15.2°, 29.6°, and 40.0°, and their composition has been plotted with the other solutions in Fig. 12, where it will be noticed that they form a line of considerable length. The composition of the solutions and their critical temperature of solution is shown in Table 12, below, numbers 1 to 6, and the course of the isotherms at the various temperatures at that point indicated in Fig. 18.

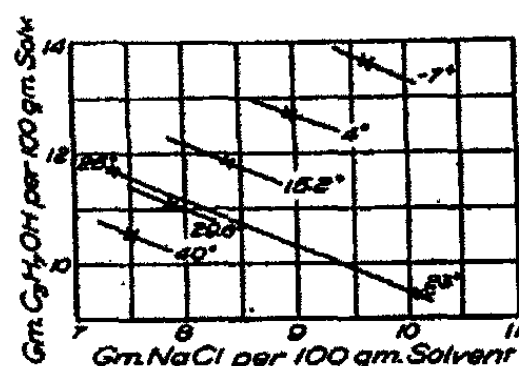

Fig. 18—Isotherms in the System: Sodium Chloride, Normal Propyl Alcohol, Water

Some experiments were also performed in solutions more dilute as to salt and more concentrated as to alcohol, and both upper and lower critical solution temperatures obtained in the same solution in some cases. The solution at the start (No. 7, Table 12) was the last one given in Table 11; it had a lower critical temperature of 25.2°. By warming and adding successive portions of water and, at the last, of alcohol, the solutions numbers 8 to 11 in Table 12 were produced. Care was taken to correct frequently for loss by evaporation, all

the experiments being conducted in a flask with a rubber cork through which passed a standardized thermometer. As the cork must be frequently loosened to relieve the pressure, there was always a loss during heating. For this reason the calculation of the results is complicated, and only the final results are given in the table.

TABLE 12

No.	Composition, grams per 100 gm. solvent			Critical solution temperature deg. C.	
	NaCl	H <sub>2</sub> O	C <sub>2</sub> H <sub>5</sub> OH	Lower	Upper
1	10.128	90.61	9.39	23.0	Not determined
2	9.652	86.40	13.60	-7.0	Not determined
3	8.983	87.35	12.65	4.0	Not determined
4	8.394	88.18	11.82	15.2	Not determined
5	7.918	88.85	11.15	29.6	Not determined
6	7.498	89.44	10.56	40.0	Not determined
7	2.280	47.25	52.75	23.0	Not determined
8	2.271	47.46	52.54	25.2	Not determined
9	2.264	47.62	52.38	27.9	Not determined
10	2.254	47.85	52.15	34.0	40.0
11	2.253	47.88	52.12	35.7	35.7 (?)
12	2.209	46.97	53.03	32.1	42.8

It will be noted that in the next to the last determination (No. 11), the upper and lower critical temperatures appear to have become identical. The solution from the previous test had been warmed a couple of degrees, and water added (0.150 gram) to just clear the solution. The temperature was now 35.7°, and on cautiously warming, no cloudiness appeared. Cooling again produced at one point a possible trace of cloudiness, which immediately disappeared. This then appears to be at a point where the two critical temperatures coincide.

As the above table contains four variables, the relations it contains cannot be plotted as they stand. One variable is easily eliminated, for purposes of plotting, by expressing the table as above, and then plotting the composition of the solvent as one variable. If the percentage of alcohol be plotted as increasing from left to right, the percentage of water

increases in a corresponding way from right to left, and both are represented by a single point. This simplification would make it possible to plot the effect of a change of temperature upon the solubility of the alcohol in a given salt solution as in Fig. 17, if we could reduce all the values in the table to the same salt content. All that we need to know for this purpose is the slope of the binodal curve at this point (determination 7, Table 12) but unfortunately this is not easy to determine accurately, as it is so steep that a small error will make a large difference in the results. By comparison with the next lower value (salt 3.686, alcohol 19.69 grams per 100 grams solvent) it would appear that over this range 0.406 gram salt per 100 grams solvent make a change of 33.06 percent in the alcohol, or 0.081 percent per milligram salt. In the other direction, taking the value for the upper layer at the quadruple point (salt 0.535, alcohol 88.28 grams per 100 grams solvent), and comparing with determination 7, we find that over this range a change of a milligram of salt gives an average change of 0.002 percent alcohol. At the point in question, the value (slope of the curve) must lie between these two numbers. But the determination 12 in Table 12 gives us a check upon the approximate magnitude of the factor. It must be such that when applied to this determination, the corrected alcohol content lies between the corrected values for determinations 9 and 10, since the lower critical temperature of 12 lies between those of 9 and 10. By trial such a factor is easily found, and we have thus been led to assume that at the point on the binodal curve for 23°, represented by determination 7, Table 12, a change of a milligram in the amount of salt per 100 grams solvent causes a change of 0.016 gram alcohol per 100 grams solvent. That is, since decrease of the salt content causes an increase in solubility of the alcohol, the observed value for alcohol is to be diminished by a value  $d_2$  such that  $d_2 = 0.016 d_1$ , where  $d_1$  represents the difference (in milligrams per 100 grams solvent) between the salt content of solution 7 and that of the solution which is to be corrected. In Table 13 these corrections have been applied,

so as to reduce all the observed solutions to the same basis as the original solution at 23°, and the value in the column headed "alcohol, corrected," represents the solubility of alcohol, in grams per 100 grams solvent, in a salt solution containing 2.280 grams salt per 100 grams solvent.

TABLE 13

Composition, grams per 100 gm. solvent					Critical solution temperature, deg. C	
NaCl	$d_1$	Alcohol	$d_2$	Alcohol corrected	Lower	Upper
2.280	0	52.75	0.00	52.75	23.0	—
2.271	9	52.54	0.14	52.40	25.2	—
2.264	16	52.38	0.26	52.12	27.9	—
2.254	26	52.15	0.42	51.73	34.0	40.0
2.253	27	52.12	0.43	51.69	37.5	37.5
2.209	71	53.03	1.14	51.79	32.1	42.8

These values have been plotted in Fig. 19, which thus represents graphically the effect of temperature upon the

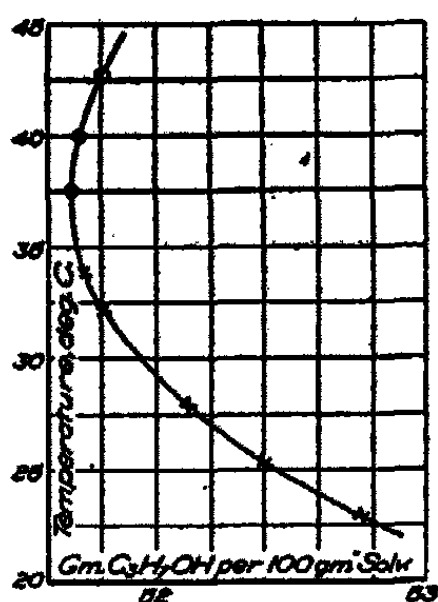

Fig. 19—Upper and Lower Critical Solution Temperatures in the System: Sodium Chloride, Normal Propyl Alcohol, Water, at a Constant Salt Content

solubility of propyl alcohol in a solution of a constant salt content of 2.280 grams per 100 grams solvent. Here, as in the

system: potassium carbonate, propyl alcohol, water, some of the upper isotherms coincide with lower ones.

#### Summary

Six ternary systems of the class salt-alcohol-water have been investigated, and the complete curves for each worked out and drawn. In those which involve hydrated salts it is shown that the solubility of the salt is greater in absolute alcohol than when the alcohol is diluted with a small amount of water; in general the solubility is about the same in absolute alcohol as in 60 to 70 percent alcohol.

A new method for the determination of ethyl alcohol has been worked out, and the results indicate that it is accurate in the presence of a small amount of methyl alcohol, if properly conducted.

It is shown for the first time that potassium fluoride has a very strong salting-out power for alcohols, and that its saturated solution is a better drying agent than a saturated solution of potassium carbonate, as it has a lower vapor pressure. The anhydrous salt itself is a good dehydrating agent, and more rapid than potassium carbonate on account of its greater solubility in organic liquids, at least in the alcohols here studied. It is also unique among drying agents of its class in the large percent of water it will take up to form its lowest hydrate.

A few experiments on the effect of temperature changes on the position of the binodal curve in the system studied, show this influence to vary greatly in quantity. Both upper and lower critical temperatures were obtained in the same solution in several cases, and apparently in one of the systems there exists a second upper critical temperature below the lower critical temperature.

Work on the higher alcohols and further work on the determination of methyl and ethyl alcohols is in progress.

*University of Minnesota*

## NEW BOOKS

**Modern Inorganic Chemistry.** By J. W. Mellor. 21 × 14 cm; pp. xx + 871. New York: Longmans, Green and Co., 1912. Price: \$2.20.—The headings of the chapters are: introduction; combination by weight; water and hydrogen; combination by volume; the physical properties of gases; hydrogen; the kinetic theory of atoms and molecules; oxygen; water; crystals and crystallization; ozone and hydrogen peroxide; osmotic pressure and related phenomena; chlorine and hydrogen chloride; the relations of chlorine—iodine, bromine, and fluorine; the oxides and oxyacids of chlorine, bromine, and iodine; electrolysis and the ionic hypothesis; the alkaline earths; beryllium, magnesium, zinc, cadmium, and mercury; the alkali metals; electrical energy; copper, silver and gold; sulphur and its hydrogen compounds; compounds of sulphur with oxygen; chromium, molybdenum, tungsten, and uranium; manganese, iron, nickel, and cobalt; the oxygen compounds of nitrogen; compounds of nitrogen and hydrogen; nitrogen and atmospheric air; phosphorus, the oxides and acids of phosphorus; arsenic, antimony, and bismuth; boron, aluminum, and related elements; the platinum metals; the oxides of carbon; hydrocarbons; allotropic forms of carbon; combustion and flame; the compounds containing carbon and nitrogen; silicon; tin, lead, and some related elements; the classification of the elements; radio-activity; epilogue.

This is a very delightful book and it contains a great deal of information, so much so that one is in doubt for whom the book is intended. It cannot have been written for the reviewer's delectation, because he did not pay for his copy. There is far too much physical chemistry in it for any introductory course as given in this country, and there is too much elementary matter for an advanced course. The preface is good enough to quote; but it throws no light on this question.

"Every teacher now recognizes that it is a sheer waste of time to introduce many abstract ideas into an elementary science course without a previous survey of facts from which the generalization can be derived. In most cases the historical mode of treatment is correct, because the generalizations have usually been developed from a contemplation of the facts; in other cases the historical treatment may involve digressions which would seriously interfere with the efficiency of the course. Obviously, a teacher will try his best to instil the maximum amount of scientific method into the facts—as prescribed by his syllabus and time-table—always remembering that the student gets more lasting benefit from the method than from the facts *per se*. In after-life the scientific method may be retained as a permanent attitude of the mind when the facts themselves are nearly all forgotten. Consequently, the justification for a general course in chemistry must be sought in the mind of the student rather than in the facts of the science. What, then, may a student expect from a general course of chemistry?

1. *Skill in observation and experiment.*—All are agreed that personal contact with facts is a great advantage. The constant absorption of statements and opinions from text-books makes a student lean so much on authority that he ultimately becomes unfitted for independent observation. Habits of self-

reliance, resource, and initiative can be acquired only in the laboratory, or by direct contact with natural phenomena. But practice in observation and experiment is not alone sufficient to develop the scientific faculty. The observational powers of a savage are usually keener than those of a civilized man, and a student may learn to observe without gaining much beyond an increased facility in the art: and he may become very skilful in experimenting without gaining much more than mere dexterity in manipulation.

2. *Memory and knowledge of relevant facts.*—Facts, of course, form the raw material which is refined by scientific methods into science itself. Consequently, many facts must be memorized by the neophyte in chemistry. Some students soon learn the trick of amassing and memorizing all kinds of information in a mechanical way. All the facts associated with a phenomenon may not be of equal importance. In practice it is not always easy to discriminate between relevant and irrelevant facts. Still, it is important to confine the attention as closely as possible to relevant and essential facts, and to discard those irrelevant and accidental. The tyro in chemistry must trust his teacher to indicate the more significant facts to be committed to memory, and used as material for exercising his intellect and wits.

3. *Ability to reason and think in a logical systematic way.*—A student must learn to reflect on the available data bearing on the problem in hand; and to explain a phenomenon by drawing legitimate inferences from approved evidence. It is a mistake to postpone the exercise and discipline of the thinking faculties until a student has memorized a vast accumulation of facts. It is necessary to form habits of reflection and thought as early as possible. Exercise means growth. The thinking faculty can be developed only through the student's own individual efforts. Just as the memory, in some subtle way, grows more vigorous with use, so the exercise of the thinking faculties enhances the power to think. Vague indefinite observing is usually followed by muddled inchoate thinking. Clear thinking presupposes clear seeing.

4. *Cultivation of the imagination.*—Some teachers have very pronounced objections to the introduction of scientific theories in an elementary course; they claim that "it is not scientific to present and discuss, say, the atomic theory in an elementary chemistry course." It might be asked what constitutes an elementary course? It would be a great mistake to suppose that science has no need for the imagination, for it is very true, as K. Pearson has said, that "disciplined imagination has been at the bottom of all great scientific discoveries;" and, as W. A. Fiske has said, that "every hypothesis and law of science is the result of a vivid imagination." Imagination helps to complete the picture outlined by observation and inference. The picture must, of course, be tested and criticized in every conceivable way to make sure that it is not a mirage among the purpled morning clouds to be dispelled by the dawning light.

5. *Development of a critical and impartial judgment.*—The imagination, though very useful, is a most dangerous ally; and a sharp line of demarcation must be observed between valid or legitimate deductions from the evidence, and what has been supplied by the imagination. Each proposition must be judged solely on its merits. There must be no shirking of the facts, no exaggeration, no distortion of the naked truth. The mind must be kept open and free from prejudice. The student must learn not to prejudge data and phenomena by ideas

formed independently of the things themselves. A teacher soon accumulates remarkable examples of the influence of expectation on judgment. If a practical class knows what quantitative result "ought" to be obtained, it is surprising how much nearer the result the majority will get than if the true result were unknown—and this without dishonest intentions. Rigorous honesty and absolute impartiality in dealing with approved evidence are indispensable. A complete absence of bias can alone give reality and meaning to scientific truths."

Some infelicities have crept in. One cannot endorse the statement, p. 165, that "according to Gibbs' phase rule, a system will be in equilibrium when its variance is equal to the number of components in the system less the number of phases increased by 2." In Table VII, p. 166, it should read unsaturated (instead of "saturated") solution of sodium chloride. On p. 170 the diagram is labelled to agree with the discussion, but both are wrong. It is not possible to do complete fractional crystallization at constant temperature though the reader would suppose so from the text, p. 171. Smith's work should have been referred to when discussing, p. 249, the behavior of calomel vapor. The reviewer would be glad to know under what conditions nickel will precipitate copper from aqueous solution, p. 362. The author has fortunately broken away from Ostwald's teachings and calls the equivalent weight the capacity factor, p. 375; but what compounds are known, p. 376, with an intensity factor of say 10 volts? The assumption of  $\text{KSO}_4$  anions, p. 459, seems quite unjustified. Text-books are apt to state, p. 471, that chromium melts at  $1500^\circ$ ; but  $1900^\circ$  is probably an under-estimate. According to the reviewer's information, the charge in the phosphorus furnace, p. 576, contains much more aluminum phosphate than calcium phosphate. Most of the geysers and hot springs in the Yellowstone Park are silicious; but the Mammoth Hot Springs are calcareous waters, p. 773.

In many places the author has prefaced a chapter or a section by a quotation from a real or an imaginary person. The reviewer regrets exceedingly that he has never said anything worthy of a place on this list. Most of us associate the epilogue with the drama; but the author has written one for his book, so it is quoted in full because one may never have another similar opportunity.

"There are not far from 200,000 different compounds known to chemists, and hundreds of new compounds are discovered every year. The specific properties of all these substances are described in dictionaries of chemistry, and in memoirs of the various scientific societies. The student of chemistry is not expected to be acquainted with more than a small fraction of these compounds. If a chemist discovers what he believes to be a new compound, it is possible to find if it has been previously prepared by consulting the literature just mentioned.

"Herbert Spencer has properly said that in so far as the production of new compounds is carried on merely for the sake of obtaining new compounds, chemistry is not a science, but an art. The best chemist is not necessarily he who is familiar with the greatest number of compounds. Chemistry is something more than a compilation of empirical facts. Dictionaries of chemistry, not the memory, are the natural storehouses of isolated facts. The intellect is perfected not by knowledge but by exercise. The time needed for memorizing a vast medley of facts can be far more profitably spent in training the brain to think clearly and logically, and the hands to do their work skilfully and accu-



rately. A student trusts his teacher to equip him with these essentials; and the conscientious teacher has, therefore, grave responsibilities. At the same time the work of the teacher may be reinforced or hampered by an examination syllabus which the student expects to traverse.

"The experience of thousands of teachers crystallized in hundreds of textbooks, syllabuses of examinations, etc., is supposed to have taught teachers what facts and principles the student of general chemistry should know. But the teacher has failed in his work if he has not whet the student's appetite for more. The subsequent progress of the student in general chemistry is, however, largely determined by his intended profession, and I question if hereafter he can do better than follow the advice of Sherlock Holmes:

"I consider that a man's brain is like a little empty attic, and you have to stock it up with such furniture as you choose. A fool takes in all the lumber of every sort that he comes across, so that the knowledge which might be useful to him gets crowded out, or at best is jumbled up with a lot of other things so that he has a difficulty in laying his hands upon it. Now the skillful workman is very careful indeed as to what he takes into his brain-attic. He will have nothing but the tools which may help him in doing work, but of these he has a large assortment, and all in the most perfect order. It is a mistake to think that this little room has elastic walls and can distend to any extent. Depend upon it there comes a time when for every addition of knowledge you forget something that you knew before. It is of the highest importance, therefore, not to have useless facts elbowing out the useful ones."

*Wilder D. Bancroft*

**The Principles of Applied Electrochemistry.** By A. J. Allmand. 22 × 15 cm; pp. xii + 547. New York: Longmans, Green and Co., 1912. Price: \$5.00.

—This book, the second one of its kind to appear within the last three years, is designed to interest the student as well as the technical man. It is divided into a theoretical and a technical part. In the theoretical part the following subjects are considered: power, Faraday's laws, current efficiency, migration of ions, conductivity, energy relations, electromotive force, cathode and anode processes, electrolytic baths, electrothermics, and electrical discharge in gases. In the technical part the following are treated: primary and secondary cells; refining and plating of metals; electrolysis of sodium chloride and other solutions, and of fused baths; preparation of iron, steel, and ferro-alloys, carbide, cyanamide, carborundum, etc.; and, finally, the production of nitric acid, and ozone. In appendices a number of tables are given.

While containing information not before published in book form, the author does not show an intimate acquaintance with the magnitude of electrochemical industries. In some cases, too, the information, about processes supposed to be in use, is out of date. A number of points throughout the book might easily have been improved upon.

Speaking scientifically, it would have been more logical to have omitted a discussion of physical chemical subjects like equilibrium in homogeneous and heterogeneous systems, phase rule, osmotic pressure, solubility product, etc., discussing more fully, the theory of electrolysis instead. The driving force in electrolysis, p. 29, is said to be the attraction of unlike charges of electricity, which, of course, would make migration depend on the distance of the ion from

the electrode. "Equivalent weight" is not satisfactorily defined. No discussion of electrolysis is given. The importance of decomposition voltage is not pointed out. The important subject of plating is not adequately treated. The discussion on the physical character of an electrolytic deposit does not show acquaintance with the literature on that subject. Explaining the more rapid solubility of cast, than wrought or hammered, metal, by saying that it is less noble, is extremely unfortunate, since just the opposite condition obtains. The question of porosity is not considered. The discussion of some important products, for instance, dry cells, and siloxicon, is short and scrappy. The size for the carborundum furnace is that used in 1907. The rôle of ultraviolet light in the preparation of ozone, and nitric oxide, is not even hinted at.

Some mistakes have crept in, for instance, the use of  $\text{dm}^3$  for  $\text{ft}^3$ , p. 304.

Throughout no hint is given as to the magnitude of any production, nor is there any attempt to tell the number of companies preparing a product or using a process. It is felt that the work is sadly wanting on this important phase of an applied subject.

The style of the book is not attractive. In fact it makes very hard reading. The drawings are mostly diagrammatic, and do not give the student an adequate idea of what commercial apparatus looks like. The book, however, is a welcome addition to a meagre collection.

C. W. Bennett

*Grundzüge der Dispersoidchemie.* By P. P. von Weimarn. 16 × 22 cm; pp. iii + 121. Dresden: Theodor Steinkopff. Price: 4 marks.—The author discusses the factors determining the size of a solid precipitate. He considers that the rate of precipitation is proportional to the percentage supersaturation—to the ratio of the supersaturation to the solubility. When the rate of precipitation is low, we get a distinctly crystalline deposit. In general it is easier to get large crystals when the percentage supersaturation is small owing to the solubility being large; but this is not essential. In one of the hot springs at Teplitz, crystals of barium sulphate have been found up to two inches in length. The concentration of barium sulphate in the water is so low that it cannot be detected analytically. In a case like this, it may easily have taken centuries to grown these crystals.

If the rate of precipitation is high, we get a higher degree of dispersity, a sol, a flocculent precipitate or a jelly as the case may be. The author believes that a jelly is always obtained if two very concentrated solutions, when mixed, produce a very insoluble substance. He illustrates this by mixing concentrated solutions of barium sulphocyanate and manganese sulphate, getting what he calls a coarse-celled, clear jelly. The reviewer believes that this part of the work is unsound. What von Weimarn has done is to get a large number of drops coated with a barium sulphate membrane. These coalesce and give him the structure he describes, but this is not a true jelly as the reviewer understands the term, because the solution inside the drops still contains barium sulphocyanate or manganese sulphate as the case may be. That these are not true jellies can be seen from the experiments, p. 67, in which the cells took the form of spirally twisted tubes.

In the latter part of the book the author discusses the conditions for stability of suspensions and also the properties of suspensions and emulsions of

substances having high molecular weights. This part of the book is distinctly not as good as the first part because the author really has no very definite theory to guide him.

Although one may object to an occasional point, there is no question but that the author's investigations are fundamental and that further work on the theory of precipitation must consist in improving and extending the author's theory and not in replacing it by an entirely different one.

*Wilder D. Bancroft*

**Die neuere Entwicklung der Kolloidchemie.** By Wolfgang Ostwald. 16 × 23 cm; pp. 23. Dresden: Theodor Steinkopff, 1912. Price: 1 mark.—The author of course rejects the old view of colloidal substances or of a colloid as being a special modification. Any extremely disperse phase is a colloidal system and consequently any substance can be converted into a colloidal state by a sufficient increase in the degree of dispersity. The experiments of von Weimarn have done much to confirm this view, and have brought out the general principles underlying all methods of preparing colloidal suspensions. In marked contrast to this are the author's remarks on peptonization since he is forced to admit that we have as yet no satisfactory theory of peptonization. One reason for this, as the author justly remarks, is that the men, who have studied this point, have usually considered each one side of the problem, instead of taking a broad view of the subject.

The author also gives a brief reference to some of the various industries based on colloid chemistry. He does not go so far, however, as the man who claimed that everything was colloid chemistry except electrochemistry and the manufacture of heavy chemicals; even here the contact sulphuric acid process belongs under colloid chemistry, while the production of graphite slabs is not far removed.

*Wilder D. Bancroft*

**Outlines of Physical Chemistry.** By G. Senter. Second edition. 13 × 19 cm; pp. iii + 382. New York: D. Van Nostrand Co., 1912. Price: \$1.75.—In the preface to the first edition the author states:

"Physical chemistry is now such an extensive subject that it is impossible even to touch on all its important applications within the limits of a small text-book. I have, therefore, preferred to deal in considerable detail with those branches of the subject which usually present most difficulty to beginners, such as the modern theory of solutions, the principles of chemical equilibrium, electrical conductivity and electromotive force, and have devoted relatively less space to the relationships between physical properties and chemical composition. The principles employed in the investigation of physical properties from the point of view of chemical composition are illustrated by a few typical examples so that the student should have little difficulty in understanding the special works on these subjects. Electrochemistry is dealt with rather more fully than has hitherto been usual in elementary works on physical chemistry, and the book is, therefore, well suited for electrical engineers."

In the preface to the second edition, it is stated, that "opportunity has been taken to revise the text thoroughly; in one or two places the wording has been slightly altered for the sake of greater clearness, and some misprints have been corrected.

"A few additions of some importance have also been made. In conformity with the elementary character of the book, the mathematical proofs of the connection between osmotic pressure and the other properties of solutions which can be made use of for molecular weight determinations were omitted from the first edition. The book has, however, been more largely used by advanced students than was anticipated, and at the request of several teachers the proofs in question have now been inserted—as an appendix to Chapter V. The section dealing with the relationship between physical properties and chemical constitution has been rendered more complete by the insertion of brief accounts of absorption spectra and of viscosity."

This elementary text-book is developed more from the descriptive standpoint than otherwise. Laws are stated and numerical examples are given, without attempting to develop these principles into a system, making them follow one another as the most logical step to take in going forward. This, however, is too rigid a requirement for an elementary text-book, since no physical chemistry published really attempts a complete logical classification and treatment. They are all made up of isolated chapters more or less.

Specifically, one or two points might be noticed. The paragraph on colloids is too short to be of any value. The dissociation theory might better have been treated under the treatment of osmotic pressure. A number of statements imply more than can be proven. For instance, the statement, p. 239, concerning the liberation of the sulphate ion at a copper electrode goes much too far. Exception might be made to the statement that indicators are all acids. The quinonoid theory is not discussed.

The book, however, aside from these minor details, is good, for an elementary text. In the absence of one written on the wider basis of logical classification and treatment of the subject as a whole, this little book fills an important place.

C. W. Bennett

*Die Kristallgruppen nebst ihren Beziehungen zu den Raumgittern.* By E. Sommersfeldt. 25 × 16 cm; pp. vii + 79. Dresden: Theodor Steinkopff, 1911. Price, 3 marks.—This is an attempt to give in condensed form an outline of the "space lattice" theory of crystal structure as developed by Bravais and more recently by Sohncke. In the effort to make the explanation as plain and simple as possible many of the further developments are omitted and the text is copiously illustrated with 14 stereoscopic photographs and 50 figures. This is the least technical discussion of the subject so far published in book form.

The two pages given to the explanation of Miller's indices are divided between an attempt to give the direct conception as projection values and the old method of "cutting distance" reciprocals. The "rhombohedral axes" are fortunately omitted although the trigonal structure is ranked with the six systems. Much of the significance of the space lattice is missed by merely describing the simple forms connected with each arrangement and not deriving them from the different "sheets of particles" possible when different directions through the lattice are selected. The line of thought, especially in the second part on lower classes of symmetry, becomes increasingly difficult to follow without a well-trained space imagination.

D. T. Wilber

THE SIGNIFICANCE OF THE RELATIONSHIP BETWEEN MOLECULAR COHESION AND THE PRODUCT OF THE MOLECULAR WEIGHT AND THE NUMBER OF VALENCES

BY ALBERT P. MATHEWS

In the preceding papers<sup>1</sup> of this series I have shown that the value of "*a*" of van der Waals, representing molecular cohesion, or the value  $M^2K$  which is the factor "*a*" for a single molecule, is proportional to the two-thirds power of the product of the molecular weight by the number of valences of the molecule.  $M^2K$  was found to be equal, when expressed in absolute units, to  $2.98 \times 10^{-27}$  (Mol. Wt.  $\times$  No. of Val.)<sup>2/3</sup>.

In this paper I shall discuss the theoretical bearing of the relationship of cohesion to these molecular properties.

Attempts have been made by others to correlate cohesion, or "*a*," with molecular weight and the number of valences, but with very partial success. Sutherland<sup>2</sup> at first supposed the molecular attraction to be proportional to the product of the gravitational masses of the molecules. This he found would not do, and in his later papers he stated that the gravitational mass of a molecule did not enter into the expression "*a*." Amagat,<sup>3</sup> also, recently revived the idea that gravitational mass plays a role in cohesion and suggested that  $a/V^2$  ought to be proportional to the square of the molecular mass. This, however, he did not find to be the case. Leduc<sup>4</sup> has recently confirmed, in part, this view of Amagat's for gases of similar molecular composition, when taken under the same volume and at corresponding temperatures. Kleeman,<sup>5</sup> also has tried to find a relationship between "*a*" and gravita-

<sup>1</sup> Mathews: Jour. Phys. Chem., 17, 154 (1913).

<sup>2</sup> Sutherland: Phil. Mag., [5] 27, 305 (1889); [6] 4, 632 (1902).

<sup>3</sup> Amagat: "Pression interne des fluides," Journal de Physique, [4] 8, 617 (1909).

<sup>4</sup> Leduc: Comptes rendus, 153, 179 (1911).

<sup>5</sup> Kleeman: Phil. Mag., [6] 19, 783, 840-847 (1910).



tional mass, and states that the cohesive attraction of two molecules is proportional to the product of the two sums of the square roots of the atomic weights of the atoms of the molecules. This relationship, however, is of very limited applicability, if indeed, it correctly expresses the cohesion of any.

As regards valence, I can find but one other suggestion, that of Sutherland.<sup>1</sup> He showed that the number of equivalents, or valences, in simple substances, such as sodium chloride, influenced the value of their cohesion. He was unable to establish this relationship for more complex bodies. Nevertheless he assumed that it existed in them and correctly surmised from it the relationship between cohesion and chemical affinity, and adduced it as evidence of the electrostatic or magnetic nature of cohesion. "*a*" was made proportional to the square root of the valence.

The relationship between cohesion and the properties of molecular weight and the number of valences can be interpreted best by Sir J. J. Thomson's theory of the electrical constitution of matter and valence, and, so far as I can see, on no other hypothesis. It speaks, therefore, for the electrostatic, or electro-magnetic theory of cohesion, and, in my opinion, for the latter.

The relation,  $M^2K = (f) \text{Val}^{2/3} / \text{Mol. Wt.}^{2/3}$ , seems at first peculiar. It is odd that the valence of an atom should be of as much importance in cohesion as the weight of the atom; it is a relationship which one would not have anticipated. The significance of this fact, if I am not mistaken, is that the electron couples constituting the molecules are of two kinds, namely, those of the atoms themselves, which added together presumably give the molecular weight; and the valence electrons, which differ from the others so that they cannot be added to them. Hence the formula is not  $M^2K = (f) (\text{Wt.} + \text{Val.})$ , the cohesion being proportional to the sum; but the mass of cohesion is proportional to the cube root of each of

<sup>1</sup> Sutherland: *Phil. Mag.*, [6] 4, 632 (1902).

these kinds of electrons and so is proportional to the cube root of their product. The valence electrons are probably more labile, more easily removed and replaced. They have a different degree of liberty and they cannot be summed with the atomic.

The formula thus confirms the correctness of Drude's promise that the electrons of the valences differ in their properties from the electrons of the atoms. He concluded that only the valence electrons would be sufficiently free to vibrate synchronously with light and hence these electrons must be particularly concerned in the refraction and dispersion of light. Drude's<sup>1</sup> suggestion of electrons of different degrees of liberty confirmed, as it was, by experiments showing a relation between valence and dispersion, is thus confirmed also from the wholly different field of cohesion.

A still more interesting conclusion may be drawn from this relationship, namely, that a neutral, uncharged atom having no valence will have no cohesion. Since it will have no chemical affinity either, if chemical affinity is, as it appears to be, of an electrical nature, it is thus seen that a close relation must exist between chemical affinity and cohesion. Such neutral atoms will presumably still have gravitational attraction. A free electrical charge on the atom is, therefore, necessary for cohesion, but not for gravitation. Furthermore, the cohesive effect is the same whether the charge be positive or negative; and it is proportional to the number of charges. The formula shows, also, that the effect of a free charge on any atom is proportional to the weight of the atom; that is, the effect of the valence charge is multiplied, as it were, by the number of electron couples in the atom; and the effect of the total number of valence charges in the molecule is multiplied by the whole number of atomic electron couples in the molecule. Just how such an effect could be produced, and why the attraction, or cohesive mass, should ultimately prove to be proportional to a linear function (the cube root) of the product

---

<sup>1</sup> Drude: *Annalen der Physik.*, [4] 14, 677 (1904).

of the number of valences by the molecular weight, I do not see.

It appears, then, that refraction, dispersion and cohesion all involve the valence electrons, but the connection between cohesion and valence is far closer and simpler than the other relationships appear to be. The relationship of valence to light is necessarily a less direct one, refraction depending on the rate of vibration of the electron. It is said<sup>1</sup> that if the natural period of the molecule (electron) is slightly less than the frequency of a light wave the light will be accelerated; if greater, retarded. It is evident that in dispersion other properties of the electrons than number come into play, and, hence, the relationship between dispersion and number is not so simple and direct. Double bonds, neighboring groups, etc., influence the periods of the electrons and so influence the dispersive power; whereas these factors appear to play no important part in cohesion.

The relation between the refraction of light of one wave length and the valence number is still less direct than between dispersion and valence, but still a general relation exists which for substances of the same type is rather uniform, as shown by Traube<sup>2</sup> for many liquids and by Cuthbertson<sup>3</sup> for several gases.

Another very interesting fact correlating the refractive and cohesive properties of matter is the resemblance between the constant "K" of the Ketteler dispersion formula and the value  $M^2K$  of cohesion. Thus with the Ketteler formula  $n^2 = a^2 - K \lambda^2 + D \lambda^2 / (\lambda^2 - \lambda_v^2)$  the constant "K," Drude found, could be computed with a fair approximation, in some cases at any rate, from the sum of the valences, the molecular weight and the density, and this result was confirmed by Erfle.<sup>4</sup> This constant "K," therefore, contains at least

<sup>1</sup> Cotter, J. R.: "Dispersion," *Encyclo. Brit.*, 11th edition, 8, 317.

<sup>2</sup> Traube: *Ber. chem. Ges. Berlin*, 40, 130 (1907).

<sup>3</sup> Cuthbertson: *Proc. Roy. Soc.*, 83A (1909-1910); *Phil. Mag.*, [6] 21, 69 (1911); *Phil. Trans.*, 204, 323 (1905); 207, 135 (1907).

<sup>4</sup> Erfle: "Optische Eigenschaften und Elektronen Theorie." *Annalen der Physik*, [4] 24 (1907).



sometimes the same factors as the value  $a/V^2$  of van der Waals' equation. I have not, however, attempted to establish any closer connection between them.<sup>1</sup>

We conclude, therefore, that while cohesion and refractivity are both dependent on a common factor, namely the valence electrons, and possibly upon the molecular weight, the connection between them is not direct, but indirect; and while cohesion and refraction, or dispersion, often parallel each other, they, at other times, diverge considerably since other factors enter into refraction.

It is not without interest to recall as an example of the perspicacity of genius, that Laplace<sup>2</sup> long ago foretold a connection between these properties. Writing in 1805 of the formula of capillarity which, as will be remembered, contained two terms, one  $K$ , representing molecular cohesion, or van der Waals' expression  $a/v^2$ ; the other,  $H$ , the capillary constant, Laplace says (p. 351): "I saw that this action (pressure) is smaller or larger than if the surface is plane; smaller, if the surface is concave; larger, if it is convex. Its analytical expression is composed of two terms: the first ( $K$ ), much larger than the second, expresses the action of the mass terminated by a plane surface; and I think from this term depends the suspension of mercury in a barometer tube at a height two to three times greater than that due to atmospheric pressure, the refractive powers of diaphanous bodies, the cohesion, and in general, chemical affinity; the second term expresses the part of the action due to the sphericity of the surface." And again (p. 362): "The function,  $K$ , is analogous to that I have designated by the same letter in the refraction of light."

But of even greater interest and more fundamental importance than the relation between the optical and the cohesive properties, which is now understandable since both

<sup>1</sup> See also Natanson: Bull. de l'Acad. des Sci. de Cracovie, 1907, April p. 316 for the relation of refraction and valence.

<sup>2</sup> Laplace: Sur l'action capillaire. Oeuvres. Supp. Liv. X, Traité de Mécanique Céleste, p. 351.

involve the number of valence electrons, is the relation between the magnetic and cohesive properties, since here we touch, I think, the very kernel of the problem of the nature of cohesion.

The connection between the magnetic properties and cohesion is brought out very clearly, in an empirical way, by Pascal's<sup>1</sup> investigations on the relation between magnetic susceptibility and the molecular properties. In a series of papers Pascal has shown that there is a remarkable connection between the specific susceptibility of diamagnetic elements and the atomic weights and valences. Thus if elements of the same family having the same valence are arranged in their order of increasing specific susceptibility, they are in the order of their atomic weights; and, on the other hand, a close dependence on valence may be observed. In elements of nearly the same weight but of different valence numbers, the atomic magnetic susceptibility,  $X_a$ , increases with the number of valences. An empirical relationship was found between them,  $X_a = -10^{-7}e^{a+\beta a}$  where  $a$  is about 2.1,  $\beta$  about 0.004 and  $a$  the atomic weight.  $a$  and  $\beta$  depend only on valence. But here, also, double bonds made their effect felt, though less pronouncedly than in refraction. Double bonded molecules have, in general, a lower molecular susceptibility than that calculated. Other effects of molecular form are seen; for example, the benzene nucleus augments the diamagnetism, although the double bonds it is supposed to contain should have an opposite effect. The factor of molecular structure appears, then, to influence diamagnetism. On the whole, however, calculation of the number of valences in the molecule by this procedure agrees better with the calculation from the cohesion, than does the calculation from the refractivity or dispersion. Thus, double bonds are of less action on the diamagnetism and in the benzene nucleus they

---

<sup>1</sup> Pascal: "Sur un mode de contrôle optique des analyses magnétochimiques," *Comptes rendus*, 152, 1852 (1911). *Recherches magnéto-chimiques sur la structure atomique des halogènes*," *Comptes rendus*, 152, 826 (1911). *Ann. Chim. Phys.*, [8] 19, 1-80 (1910).

appear to exert no effect. By this method, as by the cohesion, all organic chlorine compounds examined were found to have trivalent chlorine and fluorine was monovalent. The agreement was good in regard to other elements also.

The connection between cohesion and diamagnetism is, therefore, again an indirect one. Both involve the molecular weight and the number of valences, but it is clear that cohesion is independent of molecular form, or very largely so; whereas whether a substance is magnetic, or diamagnetic, may depend, in part upon this very factor. Oxygen in an elemental form, is paramagnetic, not diamagnetic, and is quite anomalous in Pascal's scheme; whereas the cohesion of oxygen is not anomalous. In other words, whether a body is, as a whole, paramagnetic or diamagnetic, and to what degree, depends, probably, on the possibility of the orientation of the molecules, their polarity, etc., factors which do not seem to affect their cohesion or gravitation. Nevertheless cohesion and magnetic properties are, no doubt, closely related, since both depend on the same molecular properties, only magnetism involves still other properties, (form) not involved in cohesion.

The fact that cohesion is thus determined by the number of electron couples (atomic and valence) in the molecule plainly points toward the conclusion that cohesion is either electro-static or electro-magnetic in nature. Both of these possibilities have already been suggested. Sutherland,<sup>1</sup> from his discovery of the relation of cohesion to valence in salts, inferred at first that the cohesion must be of an electromagnetic nature. He supposed these rotating electron couples acted like little magnets, and he attempted to show, though whether successfully, or not, I am unable to judge, that small magnets, at sufficient distances apart, would attract inversely as the fourth power of the distance between them, and this he supposed to be the law of molecular attraction. This conclusion was attacked by van der Waals, Jr.,<sup>2</sup> who concluded, also

<sup>1</sup> Sutherland: *Phil. Mag.*, [6] 19, 1 (1910); 4, 625 (1902).

<sup>2</sup> Van der Waals, Jr.: *Kon. Akad. v. Wetensch. te Amsterdam, Proceedings*, 11, 132 (1908-1909).

from mathematical reasoning, that the attraction between such magnets would be inversely as the 7th or 9th power of the distance, and thus agree with the assumptions of his father, that molecular attraction diminished at such a rate that it was effective only when the molecules were in contact. Later, Sutherland<sup>1</sup> concluded that cohesive attraction was due to electrostatic affinity of these electron couples. Lodge<sup>2</sup> made a similar suggestion. He thought some of the lines of force between the atoms wandered outside the molecule to atoms of other molecules and thus produced molecular cohesion. This would make molecular cohesion of the same nature as chemical affinity. While the relation between the two is close, both being zero in the absence of an electric charge, or valence, one is not causally dependent on the other, although both depend on the valences. The attraction between the atoms is probably of an electrostatic kind and, if so, should vary inversely as the square of the distance. The atomic weight does not appear to play a part in chemical affinity, for very light elements may enter into very firm union. In cohesion, molecular weight does play a large part; and while it is not impossible that the cohesive attraction may be inversely as the square of the distance, it is not probable, or at any rate it has not yet been proved to general satisfaction.

It seems much more probable to me that cohesion is more closely related to magnetism than to electrostatic affinity and I would raise the question whether magnetism is anything else than molecular cohesion made apparent at distances more than molecular. Is it not possible that molecular cohesion, involving as it does both atomic and valence electrons (atomic weight and valence) is due, perhaps, to the magnetic effects produced by the movements of these electron couples? In this view the atoms would be united by their electrostatic affinities and these same valences and the other atomic electrons by their magnetic effects produce the molecular

---

<sup>1</sup> Sutherland: *Phil. Mag.*, [6] 17, 667 (1909).

<sup>2</sup> Lodge: *Nature*, 70, 176 (1904).

cohesion. I may state briefly some of the reasons which appear to lead to such a conclusion.

In the first place we have the surprising fact that the field of cohesion of a molecule is apparently delimited by the surrounding molecules. The evidence for this, while perhaps not conclusive, is both direct and indirect. The reason for the shortness of the radius of action of cohesion is one of the most interesting questions of molecular physics. It is of interest to see how this question came to be generally considered closed and settled in favor of the view, now generally accepted, that cohesive attraction diminishes with the distance at a rate far greater than gravitational attraction. It is chiefly due to Laplace.

Laplace,<sup>1</sup> in his beautiful memoir on capillarity, first raised the question whether the short radius of attraction of the cohesive forces was due to the fact that matter shut off the attraction, or was due to the attraction diminishing with the distance at a rate far more rapid than gravitation.

He says, when discussing Hawksbee's well-known experiments proving that the height to which water rises in a glass tube is independent of the thickness of the wall of the tube: "Hawksbee a observé que dans les tubes de verre, ou très minces ou très épais, l'eau s'élevait a la meme hauteur toutes les fois que les diamètres intérieurs étaient les memes. Les couches cylindriques du verre qui sont a une distance sensible de la surface intérieure ne contribuent donc point a l'ascension de l'eau, quoique dans chacune d'elles, prise séparément, ce fluide doit s'élever au-dessus du niveau. Ce n'est point l'interposition des couches qu'elles embrassent qui arrete leur action sur l'eau, *car il est naturel de penser que les attractions capillaires se transmettent à travers les corps, ainsi que la pesanteur; cette action ne disparaît donc qu'à raison de la distance du fluide à ces couches, d'ou il suit que l'attraction du verre sur l'eau n'est sensible qu'à des distances insensibles.*" I have italicized the end of Laplace's statement to bring out

<sup>1</sup> Laplace: "Sur l'action capillaire. Oeuvres. Supp. au Livre X," *Traite de Mécanique Céleste*, p. 351; see also p. 487.

clearly the reason which led him to the conclusion that molecular cohesion penetrated matter like gravitation, and that the attraction must, hence, decrease very rapidly with the distance. It will be seen that the sole reason for his decision was the possible analogy between gravitation and molecular cohesion.

The very important result of the rejection by Laplace of the possibility of cohesive attraction not penetrating matter was that it forced him to the conclusion that the cohesive force must diminish far more rapidly than gravitation as the distance increases. Laplace did not make any assumption as to the rate at which the cohesive attraction diminished with the distance, except that it was at so rapid a rate that the cohesion became negligible within all measurable distances.

The great English philosopher, Thomas Young,<sup>1</sup> who a year before Laplace had shown the true nature of surface tension and practically anticipated all of Laplace's main conclusions, does not appear to have raised the question in a concrete form. His papers on capillarity are so condensed that the reasoning is very difficult to follow.<sup>2</sup>

But while Young nowhere specifically puts the question whether the cohesive attraction penetrates matter, he made an assumption which might be taken to indicate that it does not. "We may suppose," he says (p. 43), "the particles of liquids, and probably those of solids also, to possess that power of repulsion which has been demonstratively shown by Newton to exist in aeriform fluids, and which varies as the simple inverse ratio of the distance of the particles from each other. In air and vapors this force appears to act

<sup>1</sup> Young: "An Essay on the Cohesion of Fluids," *Phil. Trans.*, 1805 (collected works, edited by G. Peacock, 1, 418 (1855), London).

<sup>2</sup> A propos of this paper of Young's, Clerk Maxwell makes an interesting comment. He says: "His [Young's] essay contains the solution of a great number of cases including most of those afterwards solved by Laplace; but his methods of demonstration, though always correct and often extremely elegant, are sometimes rendered obscure by his scrupulous avoidance of mathematical symbols." *Ency. Brit.*, Article, "Capillarity."

uncontrolled; but in liquids it is overcome by a cohesive force, while the particles still retain a power of moving freely in all directions; and in solids the same cohesion is accompanied by a stronger or weaker resistance to all lateral motion, which is perfectly independent of the cohesive force and which must be cautiously distinguished from it." "It is sufficient to suppose the force of cohesion nearly or perfectly constant in its magnitude throughout the minute distance to which it extends, and owing its apparent diversity to the contrary action of the repulsive force, which varies with the distance. Now, in the internal parts of a liquid, these forces hold each other in a perfect equilibrium, the particles being brought so near that the repulsion becomes precisely equal to the cohesive force that urges them together," etc.

Young thus assumed that the cohesion extended but a short distance, with slight variation in intensity and that it then ended abruptly. So far as I can find, he made no suggestion how it came to end abruptly; but if it be assumed that it does not penetrate matter, it is seen that it must end abruptly at the next layer of molecules. Young tried to estimate how far the cohesive force really extended, and found a value surprisingly near the order of magnitude of that now known to be the distance apart of the centers of two molecules. His reasoning on this point is extremely ingenious, and is of interest as the first estimate of molecular dimensions.

Lord Rayleigh<sup>1</sup> says anent this computation of Young's: "One of the most remarkable features of Young's treatise is his estimate of the range "*a*" of the attractive force on the basis of the relation  $T = \frac{1}{3}aK$ . Never once have I seen it alluded to, and it is, I believe, generally supposed that the first attempt of this kind is not more than twenty years old. It detracts nothing from the merit of this wonderful speculation that a more precise calculation does not verify the numerical coefficient in Young's equation. The point is

<sup>1</sup> Rayleigh: "On the Theory of Surface Forces," *Phil. Mag.*, [5] 30, 285-298, 456-475 (1890). Collected papers, 3, 396.

that the range of the cohesive forces is necessarily of the order  $T/K$ ."  $T$  is the surface tension and  $K$  the internal pressure. Lord Rayleigh, in his revision of Maxwell's classical account of capillarity in the new edition of the *Encyclopaedia Britannica* and in his many splendid writings on this subject, does not seem to have considered this question. All other writers whom I have consulted seem to have followed Laplace's lead and assumed, without evidence, that cohesion does penetrate matter like gravitation.

Thus, Gauss,<sup>1</sup> who introduced clear ideas of surface energy and the potential energy of fluids, writes as follows in 1830: "The ordinary attraction which is proportional to the square of the distance, and which permits the representation of all motions in the heavens with such good agreement, can be used in the explanation neither of capillary phenomena nor of adhesion and cohesion; a correctly carried out computation shows 'dass eine nach diesem Gesetze wirkende Anziehung eines beliebigen Körpers der zur Ausführung von Experimenten geeignet ist, d. h., dessen Masse im Vergleich mit der der Erde vernachlässigt werden kann, auf einem beliebig gelegenen, sogar den Körper berührenden Punkt, im Vergleich mit der Schwere verschwinden muss. Wir schliessen hieraus dass jenes Anziehungsgesetz in den kleinsten Abständen mit der Wahrheit nicht mehr übereinstimmt, sondern dass es eine Modification erfordert.'" In other words, the particles of the body exert, besides the attractive force of gravitations, still another force which is noticeable only in the smallest distances. All appearances show uniformly that the second part of the attractive force (the molecular attraction) is not noticeable in the smallest measurable distances. On the other hand, in unmeasurably small distances it may greatly surpass the first, which is proportioned to the square of the distance.

<sup>1</sup> Gauss: "Allgemeine Grundlagen einer Theorie der Gestalt von Flüssigkeiten," Ostwald's "Klassiker der exakten Wissenschaften," No. 135, p. 1. "Commentationes societatis Regiae Scientiarum Göttingensis Recentiores," vii, 1830.



It was necessary for him (p. 21), to make some assumptions regarding the cohesive attraction which he represented as " $f$ " ( $r$ ),  $r$  being the radius of molecular action, and he accordingly adopted Laplace's view that  $f$  ( $r$ ) decreases far more rapidly than  $1/r^2$ , which is the law of gravitational attraction (p. 22). He says, speaking of cohesive attraction, or  $f$  ( $r$ ): "Da dieser Ausdruck etwas unbestimmtes hat so lange wir nicht eine Einheit zu Grunde legen, wollen wir vor allem darauf aufmerksam machen, dass wir die anziehende Kraft  $f$  ( $r$ ), ausgedrückt als eine Function des Abstandes  $r$ , mit einer Masse multipliziert denken müssen, damit sie mit der Gravitation  $g$  in den Dimensionen übereinstimmt. Der Sinn unserer Voraussetzung ist dann der folgende: Bezeichnet  $M$  irgend eine Masse derart, wie sie uns in Experimenten vorkommt, nämlich eine, die im Vergleich mit der ganzen Erde als verschwindend angesehen werden kann, dann muss  $M f$  ( $r$ ) immer merklich sein im Vergleich mit der Schwere, so lange  $r$  einen unseren Messungen zugänglichen, wenn auch noch so kleinen Wert hat."

Van der Waals, in all his earlier writings, including his famous essay on the continuity of the gaseous and liquid states published in 1869, assumed with Laplace that molecular cohesion was appreciable only very close to the molecule; indeed, the radius of action was less than the mean distance apart of the molecular centers. I have not been able to find in his essays any specific discussion of the question whether cohesive attraction penetrates matter, although he does discuss the radius of attraction of a molecule.<sup>1</sup> His general assumption was that the cohesion diminished very rapidly as the molecules separated. In one brief communication to the Amsterdam Academy of Sciences (1893-94, pp. 20-21) he states that he had derived a potential function, that is, a function expressing the potential energy of attraction of two

<sup>1</sup> Van der Waals: "Bijdrage tot de Kennis van de Wet der Overeenstemmende Toestanden," *Verhandelingen Konink. Akad. van Wetenschappen*, 21, 5 (1881).

molecules, of the form  $-f \frac{e^{-r}}{r^2}$ , as the potential of two mass points; and he goes on to say that this formula was based on two assumptions, namely that the attraction of two molecules is inversely as the square of the distance, and second, that the universal medium absorbs the lines of force. He thus assumes an absorption by the ether of the attraction, rather than by a molecule at a distance " $r$ ." In his paper published in 1903, in which the real molecular volume, the value of " $b$ ," is no longer considered constant and in which he has revised his formula for the isotherm in so important a manner, he does not specifically reraise the question of the penetration of matter by the cohesive attraction.

In a succession of papers like those of van der Waals' which represent a progressive succession of ideas, mutually conflicting ideas may, not unnaturally, be found. Thus, in his paper on the thermodynamic potential and capillarity,<sup>1</sup> a limiting intermediate layer of rapidly changing density is supposed to exist between the saturated vapor and the liquid, and the existence of such a layer would seem to the writer to presuppose that the radius of attraction at least in this layer must be several molecular diameters.

On the other hand, the following statement<sup>2</sup> (p. 121) is not entirely reconcilable with this view, and would be so only if the layers of which he speaks are at least equal in thickness to the distance the cohesive force extends. He supposes the cohesive pressure to be exerted only by the surface layer, but he states that exactly the same formulas are obtained if the fluid be considered to be made up of a series of layers of *molecular dimensions*. "If we consider the gas in a cylindrical vessel of constant area and divided into horizontal layers, the lowest attracts the next higher," etc. The sum of all partial amounts of work will be the same as if one considered

<sup>1</sup> Van der Waals: "Theorie thermodynamique de la Capillarité," Archives Néerlandaises des Sciences exactes et naturelles, 28, 121 (1895).

<sup>2</sup> Van der Waals: "Die Continuität des gasförmigen u. flüssigen Zustandes," Leipzig, p. 126 (1899).

only the attraction of the upper layer and the distance as that through which this layer would have been moved. It seems to me that, for this reasoning to be correct, we must assume the layers at least as thick as the radius of action of each layer of molecules. If these layers are of molecular diameters, it would seem that the cohesive force does not extend farther than a molecular diameter. This is not apparently consistent with the assumption elsewhere made to explain the transitional layer between vapor and liquid.

Plateau also followed Laplace. Sutherland, in his many papers on molecular cohesion, assumes that the cohesive attraction is inversely as the fourth power of the distance, but he does not, so far as I can find, discuss the question of the penetration of matter by cohesive attraction. But it is impossible for cohesion to vary inversely as the fourth power, if cohesion penetrates matter.

Kleeman<sup>1</sup> supposes that the attraction must be inversely as the 5th or some higher power of the distance. He has pointed out that cohesion cannot possibly be assumed to vary like gravitation inversely with the square of the distance, because the cohesive attraction is so much greater than gravitation. But Mills weakened the force of this objection, which he had overlooked in his early papers, by making the additional postulate that cohesion does not penetrate matter. For if it be assumed that the cohesion does not penetrate matter then only the layer of superficial molecules of two masses would attract each other; and the number of these is so small, compared to the whole number of molecules in the mass, that the cohesive attraction would be less perceptible at sensible distances than gravitational attraction.

I have been unable, then, to find any evidence for the assumption so generally made that cohesive attraction penetrates matter like gravitation. There is no direct evidence, therefore, so far as I can find, against the inference necessitated

---

<sup>1</sup> Kleeman: "An Investigation of the Determination of the Law of Chemical Attraction between Atoms from Physical Data," *Phil. Mag.*, [6] 21, 83 (1911).

by the square or fourth power law of attraction, that cohesion does not penetrate matter.

There is, on the other hand, some evidence of a direct kind that cohesive attraction extends only as far as the nearest molecules. This evidence is the length of the radius of action as determined by direct measurement, and Einstein's proof that the radius of action varies with the distance apart of the molecular centers.

Laplace believed that the radius of action, although short, nevertheless extended many molecular diameters and this opinion prevailed until recently, but as means of measurement have improved the radius has shrunk. Quincke gave an estimate of about  $6 \times 10^{-8}$  cm, but the most recent determinations of Johannot,<sup>1</sup> and Chamberlain<sup>2</sup> show it to be about  $1.6-2 \times 10^{-7}$  cm in a soap film and in the case of glass. The diameter of a molecule of trioleate of glycerine, according to Perrin,<sup>3</sup> is  $1.1 \times 10^{-7}$  cm. The radius of action is certainly not more than two molecular diameters and indeed is hardly more than one. The average distance between the centers of two molecules of ether in the liquid state at  $20^\circ$  is about  $5.5 \times 10^{-8}$  cm.

But not only has direct measurement shown the radius of action to be one or two molecular diameters, but computations of it by Kleeman make it very close to this. For example, in ether Kleeman<sup>4</sup> computed the radius to be about  $3.4 \times 10^{-8}$  cm which is about the distance when the molecules are in contact. Van der Waals supposed it, indeed, to be only as long as this. Recently Einstein<sup>5</sup> has made a very interesting computation starting from the law of Eötvös, by which he shows, from thermodynamic reasoning, that the

<sup>1</sup> Johannot: *Phil. Mag.*, [5] 47, 501 (1899).

<sup>2</sup> Chamberlain: *Phys. Rev.*, 31, 170 (1910).

<sup>3</sup> Devaux: *Journal de Physique*, [5] 2, 699 (1912).

<sup>4</sup> Kleeman: "On the Radius of the Sphere of Action," *Phil. Mag.*, [6] 19, 840 (1910).

<sup>5</sup> Einstein: "Bemerkung zu dem Gesetz von Eötvös," *Annalen der Physik.*, [4] 34, 165 (1911).

range of cohesive action must be of the general value of, and proportional to, the distance between the molecular centers. This distance is of the order of magnitude in most liquids of  $10^{-8}$  cm. This result is so surprising that Einstein says of it: "This result appears at first very unlikely, for what should the radius of action of a molecule have to do with the distance between neighboring molecules? The supposition is only reasonable in case the neighboring molecules alone attract each other, but not those farther removed."

Sutherland<sup>1</sup> also came to the conclusion that the radius of action was about equal to  $v^{1/3}$ . We see then, that the evidence points to the conclusion that the radius of action of the molecular forces agrees very closely with  $v^{1/3}$ , the distance between the molecular centers, and varies directly with  $v^{1/3}$ . The only explanation of this fact appears to me to be that the attraction does not extend beyond neighboring molecules and, hence, must, in some way, be stopped by them.

Mills<sup>2</sup> alone, so far as I can find, has reopened the question whether the field is delimited by the surrounding molecules. Concluding, I believe erroneously, from an empirical law, that the attraction between molecules must vary inversely as the square of the distance, he was driven to the second conclusion that if this were the case the cohesion could not penetrate matter. He assumed, hence, that the surrounding molecules absorbed, or neutralized, the lines of cohesive force. The direct evidence and Einstein's reasoning leaves little doubt that the radius varies with the distance apart of the molecules and the only possible conclusion from this is that the surrounding molecules delimit the field as Mills supposes.

If it is a fact that the surrounding molecules delimit the field as the evidence indicates, cohesion is allied at once with magnetism, for this is the very supposition which Ewing made to explain some of the phenomena of magnetism. Each molecule of a ferromagnetic substance is supposed to be a

<sup>1</sup> Sutherland: *Phil. Mag.*, [6] 4, 632, 636 (1902).

<sup>2</sup> Mills: *Jour. Phys. Chem.*, 15, 417 (1911).

magnet. In the non-magnetic state the magnetism of each molecule is supposed to be neutralized by the surrounding molecules, which have their magnetic axes variously directed. The magnetic field is thus limited to a single molecular diameter and will vary with the distance apart of the molecules. The magnetic field of each molecule is delimited by the surrounding molecules. If, however, these molecules are oriented, either by acting on each other, or by external forces, then the magnetic fields coincide and the magnetism may be perceived extending outward from the mass. In other words, to explain why magnetism does not persist in soft iron and to account for magnetic hysteresis, Ewing has made exactly the same assumption which has been made to explain why cohesion does not extend beyond molecular distances.

It seems to me not impossible that magnetism is the cohesive attraction of a molecule. If the molecule is of such a nature, or shape, that the total effect of the little magnets, its electron couples, coincide more or less completely so that the molecule has a polarity, and the molecules can be oriented in any way and held in position, we have the ferro and paramagnetic substances. If the molecules have many poles, so that there is no polarity of the molecules as a whole, there is a diamagnetic substance. The magnetic field of each molecule would be its cohesive field.

The recent work of Cotton and Mouton<sup>1</sup> on the orientation of molecules in the magnetic field seems to me to bear out such an interpretation. The work of Weiss<sup>2</sup> and Langevin<sup>3</sup> appears to point in the same direction, but Weiss, who has considered the possibility of the identity of cohesion and magnetism, states that he will shortly show that they can not be identical. Nevertheless it appears to me not impossible that magnetism is simply a special case of cohesion, and if this is true the rotation of the plane of polarized light by optically active substances would be easily understood.

<sup>1</sup> Cotton and Mouton: *Journal de Physique*, [5] 1, 40 (1911).

<sup>2</sup> Weiss: *Journal de Physique*, [5] 1, 900 (1911); [4] 6, 661 (1907).

<sup>3</sup> Langevin: *Ann. Chim. Phys.*, 5, 70 (1905).

Finally, if it is true that the surrounding molecules delimit the field of cohesion in any way whatever, and that only six molecules really take part in this delimitation, we can derive the value  $a/V^2$  of van der Waals' at once and very simply.

Suppose that each molecule has a certain mass of cohesion,  $M$ , and that two molecules attract each other directly as the product of their cohesive masses and inversely as the fourth power of the distance between their centers, then the attraction between two molecules would be  $M^2K/v^4$ , where  $v$  is the space at the disposal of a single molecule. Since each molecule attracts only the one above, below and to each side, the pressure per square centimeter of a double layer of molecules will be  $M^2K/v^4$  multiplied by the number of molecules in 1 sq. cm or  $1/v^3$ , making  $M^2K/v^2$ . Since the attraction extends only a single molecular diameter, we may multiply both numerator and denominator by  $N^2$ , where  $N$  is the number of molecules in the volume,  $V$ , and we obtain,  $N^2M^2K/N^2v^2 = M^2N^2K/V^2 = a/V^2$ .  $M^2K$  has already been shown to be  $2.98 \times 10^{-37}$  (Mol. Wt.  $\times$  Valences)<sup>2/3</sup>.

We have, as yet, no proof that only the six surrounding molecules are attracted, although Sutherland<sup>1</sup> has made a similar supposition. But such may be the case nevertheless. Einstein, in his calculation, computed that each molecule could be considered as lying at the center of a cube and that it attracted the 26 other molecules of the cube. Of course the fact that the value  $a/V^2$  may be so easily derived in this way does not furnish any proof that the attraction is inversely as the fourth power of the distance. But I know of no other derivation of  $a/V^2$  which involves so few, or less radical, assumptions.

The general conclusion of the paper is then, that cohesion,

<sup>1</sup>Sutherland: *Phil. Mag.*, [6] 17, 667 (1909). "The total potential energy of a number of like molecules is the same as if each caused its own domain to be uniformly electrized with an electric moment proportional to the linear dimensions of the domain, the direction of electrization being such that in general any molecule attracts its six immediate neighbors."

being a function of molecular weight and valence, is a function of the number of electron couples of the valences and atoms, and is, hence, probably of a magnetic nature. Magnetic substances may be supposed to be substances in which, owing to the orientation of the molecules, or to their polarity, or both these causes, the cohesive fields of the molecules are not delimited or neutralized by the surrounding molecules so that the cohesive attraction becomes apparent at more than molecular distances, and under such circumstances the substance is said to be magnetic.

*University of Chicago*



## THE THEORY OF EMULSIFICATION, V

BY WILDER D. BANCROFT

Mr. Charles E. Swett has called my attention to the fact that wool fat forms an emulsion with water in which the water is present in drops.<sup>1</sup> "Although insoluble in water, wool wax possesses the remarkable property of absorbing larger quantities of water than any other wax. The emulsion it forms with water has the appearance of a perfectly homogeneous mass. This wool wax can be mixed with as much as 80 percent of water. A mixture of neutral wax and water, containing about 22-25 percent of the latter, is sold in commerce under the name lanolin."

"Owing to its property of forming an emulsion with water which will not separate into two layers even after several years standing, and to the ease with which it is absorbed by the skin, wool wax is used as a basis for ointments and cosmetics. The British Pharmacopoeia recognizes two preparations, viz., *Adeps lanae, i. e.*, pure wool wax, and *Adeps lanae hydrosus, i. e.*, hydrous wool wax, better known under the trade name of lanolin."

I have not been able to find out whether other ointments containing water have the water as drops or not; but it seems probable that some do. Shoe blacking contains oil, water and other materials. It may, therefore, be considered as an emulsion; but I have not been able to find any statement as to the type and we have not yet had time to study it in the laboratory.

Mr. Swett tells me that drops of water in oil can be obtained by the use of rosin. The directions are to dissolve rosin in mineral oil, using heat. When the mixture is cold, add water in small proportions and shake. As much as one hundred percent of water may very easily be taken up in this way.

<sup>1</sup> Lewkowitsch: "Chemical Technology and Analysis of Oils, Fats and Waxes," third edition, 2, 879, 883 (1904).

Lime and alumina soaps are used in lubricating greases. The addition of water produces some rather surprising results.<sup>1</sup> "Though the composition of these greases varies somewhat, most of them consist of a solution of lime soap (15-23 percent, and occasionally more) in a heavy mineral oil with the addition of a little water (sometimes as little as 0.5-0.7 percent, but usually 1-4 percent). As secondary constituents we have small amounts of unsaponified fatty oils, glycerol, free lime, free fatty acid, as well as substances added to mask the color, odor or fluorescence. In some greases there are also alkali soaps. For technical use these greases are usually manufactured by dissolving a previously prepared lime soap in mineral oil and mixing a small amount of water intimately with the resulting solution. It is only occasionally that these greases are prepared by dissolving a saponifiable oil in mineral oil, saponifying with lime, and adding enough water so as to obtain, on stirring, the vaseline-like or tallow-like consistency characteristic of lubricating greases.

"The lubricating greases offer a series of interesting problems in physical chemistry, which have not yet been studied from a scientific view-point. Among these problems are: the determination of the factors giving rise to the peculiar consistency; the determination of the reason why the greases often break up spontaneously into a thin, oily, portion and a solid portion; and the explanation of the part played by the addition of water."

"No clear understanding has yet been reached in scientific or technical circles in regard to the relation between the amount of water and the properties of the lubricating greases. Among technical men the belief is prevalent that the water combines with the soap to form a compound analogous to salts with water of crystallization. This erroneous assumption is also often made in regard to the alkali soaps. Observation shows that the water is usually present in a state of very fine mechanical subdivision. This much is certain, that a

<sup>1</sup> Holde: *Zeit. Kolloidchemie*, 3, 270 (1908).

certain amount of water is necessary in the grease to produce a satisfactory permanency, since all the greases that do not contain water soon become clearly inhomogeneous. As the technical men say, they let go of the oil.

"Some experiments were made on the relation between the amount of water and the resulting consistency and transparency of the greases. A 22 percent viscous solution of a rape-seed oil lime soap was made by heating twenty-five parts of rape-seed oil with 2.13 parts slaked lime to 220°-240°, in a heavy Russian mineral oil. At room temperature, this solution would drip from a glass rod. On adding 1-2 percent water, the liquid mass became like a salve as soon as the water was distributed as a fine solution through the oily mass. On the other hand, a solution of lime soap in oil remained unchanged in consistency when rubbed in a mortar without water. In contradistinction to the clear water-free solution of the soap, the emulsion was distinctly cloudy and only began to drop at 70° in Ubbelohde's apparatus. . . . . After dropping, the very fine emulsion was found to have cracked. . . . .

"Changes in consistency, like that described, have been noticed by K. Beck<sup>1</sup> in a study of emulsions of gum arabic solutions with castor oil. The viscosity increased very much. A characteristic sign of the moment of maximum formation is a peculiar crackling of the rubbed mass. The increase of the viscosity as the mass changes from an oil to an ointment is probably due to surface forces which only become important when the water particles are distributed as very fine drops through the oil, since the water, before that, moved through the oil without hindrance under the influence of gravity. The dripping at higher temperatures can be accounted for on the ground that a higher temperature works against the surface forces and tends to destroy the emulsion. The salve-like consistency is obtained only when the water is distributed in microscopic particles through the grease.

<sup>1</sup> Zeit. phys. Chem., 58, 409 (1907).

So long as one can see droplets, the conditions are lacking for producing the consistency of a salve.

"The degree of clouding stands in a definite relation to the water content in the case of many greases. In one case, for instance, the mercury bulb of the thermometer in the Ubbelohde apparatus was distinctly visible when the cylindrical glass vessel was filled with a grease containing one percent water while it could scarcely be seen when the grease contained two percent water. On raising the temperature the transparency increases, especially in the neighborhood of the drip-point. This is evidently connected with the decreased stability of the emulsion.

"After standing a while, there is often a surprising increase along the edges of a grease which has been clouded by addition of water. Very often there separates, at these points, a small amount of a clear oil containing dissolved lime soap. This is probably due to the evaporation of water from the surface of the grease exposed to the air, because the presence of water is essential to the maintenance of the emulsion with soap and oil.

"If the amount of water is increased too much, the greases of this type become too cloudy and the viscosity decreases. This is the reason why a water content of seven percent is rarely exceeded. The amount of oil has an effect on the consistency which could scarcely be predicted. If one dilutes a stiff grease with oil so as to make a less stiff one, which does not adhere to the mortar and pestle for instance, the drip-point is not lowered appreciably but drops begin to form 30° to 40° lower than before. Similar large differences between the first formation of drops and the drip-point are also to be noticed with such greases as have been made with too thin oil or with a heavier oil under unsuitable conditions of heating. The differences between the first formation of drops and the drip-point is of considerable importance in technical work and the fluid nature of a solution of lime soap in oil before mixing with water is not considered a disadvantage in preparing a sufficiently stiff grease.

"Like other colloidal solutions, the stiff greases show hysteresis phenomena. It is easy to notice qualitatively that soft greases, which flow in a mortar when the latter is moved slowly, lose this mobility on standing and become stiffer. This shows itself numerically by a rise in the temperature at which drops begin to form, though the drip-point of a grease which has been stored remains approximately the same as that of the fresh grease.....

"The changes in the softening point are obviously connected with the hysteresis phenomena which can also be observed with the water-free solutions of lime soaps in oil. These solutions are quite oily and clear when fresh; but become inhomogeneous after standing several days, and sometimes even sooner. A jelly-like lime soap separates, in the same way that jelly-like masses separate from rubber solutions or other colloidal solutions. The filtrate at room temperature proved on analysis to contain 1-2 percent soap, the original soap solution contained 22 percent soap, and the thick jelly on the filter contained 15 percent soap.<sup>1</sup> Similar changes in homogeneity undoubtedly take place in greases to which water has been added; but the emulsification of the drops of water prevents these changes from being visible except as they displace the temperature at which drops begin to form.

"When the anhydrous solution of 20-22 percent lime soap in heavy Russian machine oils solidifies to a gel, its drip-point is about 30°, quite different from that of the salve-like mixtures which have been rubbed with water. If the jelly is shaken, however, the drip-point drops about to room temperature. After heating and slow cooling, the drip-point rises occasionally above 30°.

"With oils containing small amounts of lime soaps, such as the filtrates previously referred to, fine films form on the surface after long standing, so that it seems probable that all these solutions of lime soap are really supercooled colloidal

<sup>1</sup> [It is difficult to see how a soap solution could separate into two portions, each having a lower percentage of soap than the original solution. W. D. B.]

solutions which all have a tendency to precipitate the excess of soap. The previously described lubricating greases are to be considered as salve-like emulsions of these supercooled solutions of lime soap in mineral oils and of the precipitated, jelly-like colloidal lime soap together with a little water. The drip-point of all these greases is about  $70^{\circ}$ .

“Quite different results are obtained when the lime soap is prepared by precipitating a rape-seed oil alkali soap with calcium chloride instead of by heating, and 20 percent of this precipitated soap was dissolved in a light American mineral oil containing paraffin. The precipitated soap was granular and clear yellow, quite different from the brownish, translucent, viscous and jelly-like boiled soap. It dissolved with such difficulty in oil that gelatinous, crumbly, readily-hardening masses were formed on heating, even when there was continuous stirring at  $210^{\circ}$ . When solid the mass was a deep brownish red, transparent, and stiff jelly. In it could be seen lighter particles of apparently undissolved soap. In Ubbelohde's apparatus, the drip-point was found to be about  $90^{\circ}$ , while drops began to form at  $75^{\circ}$ - $80^{\circ}$ . When a brown emulsion was prepared from this jelly with one percent water, it remained fluid even after long standing. Since the anhydrous jelly cracked in a short time to soap and a mobile oil, the peculiar liquefaction of the originally solid mass, when mixed with water, can perhaps be explained by assuming that the solid jelly is a mechanical mixture of a mobile, soap-like oil containing a mass of crystallized lime soap which latter causes the high drip-point.

“Another sample was prepared by dissolving 6.2 percent soap in oil at  $225^{\circ}$  and rubbing into it one percent of water. It was also reddish brown and fluid while the anhydrous mass, before the water was added, was jelly-like at  $28^{\circ}$ , but very mobile. A liquid layer separated on standing. Five other greases were prepared from the light American oil. In the first, 6.2 percent of precipitated soap was dissolved at  $255^{\circ}$ . The solution formed a thin jelly when cold and a thick layer

of it became partially liquid on standing. When ground with one percent water, there was formed a stiff vaseline-like, dark reddish-brown grease, which was transparent in thin layers and which began to form drops at  $25^{\circ}$  when freshly prepared, but which showed a drip-point of  $74^{\circ}$ . The other sample was made with boiled soap and with the same mineral oil. The boiled soap dissolved between  $80^{\circ}$  and  $90^{\circ}$ , but stiff greases were not formed unless the solution was heated higher ( $205^{\circ}$ ). An 18 percent solution, heated for five minutes at  $205^{\circ}$  and ground with one percent water, began to form drops at  $37^{\circ}$  and dripped at  $57.5^{\circ}$ . A similar solution was heated for 15 minutes at  $205^{\circ}$  and then ground with water. The resulting grease began to form drops at  $46^{\circ}$  and dripped at  $66^{\circ}$ . Longer heating thus raised both temperatures. . . . .

"To show the colloidal character of the lime soap solutions, some experiments were made with the ultra-microscope since a boiling-point determination was out of the question in view of the nature of the high-boiling constituents. The solution of the lime soap in the heavy mineral oil was diluted with benzene so as to make observations easier. Under the ultra-microscope it proved to be amicroscopically colloidal. Solutions of precipitated lime soap in pure benzene showed a bluish cone of light, and innumerable submicrons. Solutions of lime soap in a mixture of benzene and alcohol were seen to be colloidal when examined under the ultra-microscope. In the case of these greases we have not only a colloidal solution of lime soap in mineral oil but also a colloidal solution of resins in the oil. This was confirmed by examining the reddish-brown and black opaque mineral oils and their mixtures with benzene. The dark asphalts and the lighter resins were colloiddally amicroscopic.

"When a few drops of a dark railroad oil were dissolved in benzene and placed before the slit of the ultra-microscope, a beautiful, bluish-green cone of light was to be seen. Under the ultra-microscope the solution appeared entirely amicroscopic. If one adds concentrated alcohol to the benzene solutions of dark oils which contain dissolved asphalt, or if

one adds alcohol to an apparently amicroscopic solution of pure asphalt in benzene, the apparently clear and transparent solution shows, under the ultra-microscope, submicrons which are evidently precipitated asphalt, but which cannot be seen as such by the naked eye.

"Reddish-yellow machine oils give a bluish cone of light containing amicrons. The solution of lime soap in a Russian machine oil was also amicroscopic. A white paraffin oil gives a beautiful bluish cone of light containing amicrons. Crystallized paraffin, with a melting point of  $38^{\circ}$ , differs from asphalt in giving no sharp cone of light when small amounts are dissolved in benzene. It is only when considerable amounts of paraffin are dissolved in benzene that we get a cone of light with submicrons sparkling very beautifully. A similar result is obtained with a normal paraffin melting above  $50^{\circ}$ . The cone of light is due chiefly to amicrons and is scarcely colored. There are more submicrons, the more concentrated the solution. Submicrons were scarcely to be found in Russian petroleum in which there is almost no paraffin, but they were to be detected in the American petroleum which contains more paraffin and which solidifies more readily."

In these lubricating greases we have water as the disperse phase, the lime soap forming the protecting film. The consistency is due to the structure of the emulsion. Since there is present about 20 percent of lime soap, the emulsifying agent it is not surprising that there is a marked change in the physical properties, especially in view of the fact that Pickering<sup>1</sup> obtained a practically solid mass resembling blanc-mange by emulsifying 99 parts kerosene with one part of a one percent potash soap solution. Holde does not give sufficient details to enable me to discuss the alleged difference in behavior of a lime soap made by treating rape-seed oil with lime and of a lime soap made by adding calcium chloride to a soda or potash soap. There is presumably no glycerine in the second case and there is probably some soda or potash soap carried

<sup>1</sup> Jour. Chem. Soc., 91, 200 (1907).



down. It is rather a pity that Holde should have changed the method of preparing the lime soap and the nature of the mineral oil at the same time.

Another instance of an emulsion in which water occurs in drops is to be found in the case of mixed paints.<sup>1</sup> "The manufacture of mixed paint is essentially American, having been accredited to some enterprising New Englanders who observed that when linseed oil paint was mixed with a solution of silicate of soda (water-glass) an emulsion was formed, and the paint so made showed very little tendency to settle or harden in the package. Several lay claim to this invention. The first mixed paint was marketed in small packages for home consumption and appeared about 1865.

"The addition of silicate of soda is still practised by a few manufacturers, but the tendency is to eliminate it as far as possible and to minimize as much as possible the use of an alkaline watery solution to keep the paint in suspension. The general use of zinc oxide has had much to do with the progress of mixed paint, for it is well known that corroded white lead and linseed oil settle quickly in the package, while zinc oxide keeps the heavier lead longer in suspension. Where only heavy materials are used, manufacturers are inclined to add up to four percent of water. . . . .

"In certain classes of mixed paints, particularly house paints which are made of corroded lead, sublimed lead, barium sulphate, etc., there is a likelihood or tendency of the pigment to settle. This is more marked in the case of corroded lead than in any of the other pigments. To prevent this, in a measure, water is added, and up to a certain percentage both the manufacturer and the consumer have accepted the fact that water is not injurious when added to two percent for the purpose of combining the paint; but beyond this percentage its effect is likely to be injurious.

"Sometimes for the sake of an argument, but more often

---

<sup>1</sup>Toch: "The Chemistry and Technology of Mixed Paints," 11, 116 (1907).

for the sake of making a paint which contains no more water than the natural moisture of its constituents, a manufacturer feels the necessity of adding a combining medium other than water to prevent the paint from settling hard in the package. Among these are gutta-percha solutions, solutions of balata, para-rubber, gum chicle, etc. The rubber solutions mentioned serve their purpose very well without injuring the paint, and the percentage used is so small that it may be considered negligible. This, however, is not true of many of the mixing varnishes which are made by varnish manufacturers who have no experience in the manufacture of paint. They sell rosin varnishes neutralized with lime, lead or manganese, and while they assist very well in combining the lead with the oil, the wearing quality of the paint is proportionately reduced.

“With the last few years a new combining medium has appeared on the market which in itself is an improvement on all paints. It is made by melting a mixture of a resin (free from rosin or colophony) and heavy linseed oil and reducing with China wood oil and naphtha. Where a manufacturer uses a combining medium of this character the paint becomes more viscous as it grows older, and when it dries it produces a satin-like gloss and shows fewer brush marks than a paint containing water.

“The question of how much water shall be added to mixed paints, or how much water mixed paints shall contain, either added or incidental, is not fully decided upon, as there is a difference of opinion as to its value, and likewise a difference of opinion as to the amount necessary for certain purposes. There are some paints in which as high as 2 percent water are necessary, and in other paints less than 1 percent is purposely added. That water is of great benefit in certain paints cannot be disputed, one large railway corporation permitting the addition of 1 percent of water to its mixed and paste paints.

“A chemist in making an examination of a mixed paint must necessarily be careful in giving an opinion as to the amount of water in the paint, and great judgment must be

used in a report. For instance, a paint, made according to a certain specification, containing a large mixture of Venetian red and yellow ochre, might contain very nearly 2 percent of moisture, which was a part of the composition of the pigment. Then again, linseed oil frequently contains more than a trace of water, which the manufacturer cannot extract nor can he afford the time necessary to allow the water to settle out of the oil. A mixed paint should not contain over 2 percent water, for it is unnecessary to add more than this amount to any paint.

“The proper benefits derived from the addition of water to a pure linseed oil paint are suspension of the pigment and improvement in its working quality. Take the case of artists' tube colors which lie on the dealers' shelves for years and which are prone to get hard and likely to separate so completely that the color will be found on one side of the tube and the oil entirely free on the other. Water is an absolute necessity in this case and is an improvement for both seller and user. The colors made with the correct addition of water are known to pile and artists prefer a color which “piles” properly.

“There are many ways of adding water to a paint. In some instances the required amount of water, together with the oil and the drier, are placed in a churn or mixer and the paste stirred in. Where materials like calcium sulphate, calcium carbonate, ochre, Venetian red, silicate of magnesia, silicate of alumina, white lead, etc., are used, there is no necessity for adding any combining material which will form a soap with the linseed oil, there being sufficient action between these materials and the water. It is an additional advantage that there is less likely to be complete saponification in a mixed paint to which no emulsifier has been added.

“There are a large variety of materials which are used for ‘emulsifying’ paint, some of which are good and some of which tend to gelatinize the paint. The materials used for ‘emulsifying’ paint are the carbonates of all the alkalis, borax; zinc sulphate, calcium hypochlorite, manganese sul-

phate, manganese chloride, ferric chloride, lead acetate, ferrous sulphate, alcoholic solutions of these various salts, also the alcoholic solutions of these salts containing a small percentage of moisture.

"To detect water in paint, particularly in light-colored paints, is a comparatively simple matter. The method devised by the author is almost quantitative for some purposes. The first method ever published by the author consisted in placing a strip of gelatin in a mixed paint. When a measured or weighed amount of mixed paint was taken and the strip of gelatin allowed to remain for twenty-four hours a fairly correct quantitative determination was obtained. Another method described some years ago involved the use of anhydrous sulphate of copper, a bluish-white powder which on the addition of water returns to the natural dark blue color of crystallized copper sulphate.

"The author has, however, devised the scheme of using a glass plate and mixing a paint with a dyestuff known as Erythrosine B. When about  $\frac{1}{2}$  gram of the dye and 5 grams of mixed paint are rubbed together with a pallet knife on a sheet of glass, a paint containing no water will produce a distinct pearl-gray color; if there is water in the paint the mixture changes almost immediately to a brilliant cerise red, and if there is much water in the paint (over 2 percent) the color changes into a crimson so that the reaction is clearly marked. The test must not be allowed to stand more than four minutes, since even paints which contain no added water but which naturally contain traces of moisture will begin to change into a rosy color, but this indication points to the absence of water.

"In a red, black, or other dark-colored paint where this color reaction cannot be seen, the oil must be separated from the pigment and a test made of the oil on a sheet of milk glass. It is always necessary to run a blank alongside of the test, the blank being of known composition. For instance, in testing a yellow paint composed of ochre, a certain amount of water will be found in the dry color. It is

therefore necessary to make a yellow paint containing ochre and test it with erythrosine and note how long it takes for the water in the ochre to attack the erythrosine. The suspected sample is then tested, and if it changes in the same time as the known sample, no added water can be reported. A white paint very largely composed of moist white lead will show the erythrosine reaction in a few minutes, and a chemist who has standard samples of known composition at hand will find this test both delicate and useful.

"There are a large variety of indicators such as nigrosine black, insoluble in alcohol but soluble in water, which are very useful indeed. Some manufacturers have been known to add a borax solution of rosin and shellac, which contains a small percentage of wood alcohol, to certain paints.

The wood alcohol in this case would give a very brilliant color with the erythrosine, but the nigrosine being insoluble in alcohol would give its color only with water."

Holley and Ladd<sup>1</sup> say that "many of the paints which have been sent out of late years have contained unnatural proportions of water, not intended to add value to the paint, or to serve for preventing its settling and hardening. No more than from one to two percent of water is needed, if at all necessary, for this purpose. It is not uncommon for paints to contain from ten to twenty-four percent of water in the liquid portion. This, with the small amount of added alkalies and jelly-like constituents, has produced serious results for the paint consumer."

I have not been able to find any statement as to the type of the emulsion formed when water is added; but it seemed to me self-evident that 24 percent of water would readily be detected in case the water were the external phase, and consequently it seemed justifiable to assume that in mixed paints we had water emulsified in oil. This assumption was confirmed in my laboratory by Mr. F. R. Newman who tested a sample of mixed white lead and added more water to it

<sup>1</sup> "Analysis of Mixed Paints, Color Pigments, and Varnishes," 5 (1908).

until the paint contained over 70 percent of water. It was also found that water emulsifies in commercial linseed oil, this undoubtedly being due to the rosin content of the oil. Since there are said to be seventy million gallons of mixed paints used per year in the United States, this type of emulsion is unquestionably the more important one commercially, and it is rather extraordinary that the writers on emulsions should have overlooked this important industry.

It seems to me that we are now in a position to consider the conditions under which one or the other type of emulsion occurs. Donnan's surface tension theory of emulsions is certainly not right in the form in which it has hitherto been given. Pickering<sup>1</sup> brought this out clearly when he prepared emulsions of oil in water with basic iron sulphate. On the other hand, no one will deny that the formation of an emulsion is a phenomenon involving surface tension. Consequently, some point has been overlooked in Donnan's theory. Donnan is quite right in pointing out<sup>2</sup> that the stability of an emulsion depends on the fact that a surface film with a low surface tension tends to prevent a coalescence of the drops of oils. He is also right in the reason given for it. The weakness in Donnan's theory is due to the fact that Donnan has always started with the fact that the oil is emulsified and that he has consequently never formulated the conditions under which the oil becomes the disperse phase rather than the water. Donnan considers the surface film in the case of soap emulsions as part of the water phase though differing in concentration from it. All the difficulties disappear if we consider the surface film as a separate phase, so that we have drops of oil, a surface film, and surrounding water. We must do something of this sort in the case of foams or soap-bubbles, because there it is absurd to consider the film as part of the enclosed air or of the external air. In the case of the soap-bubble, the compositions of the phases inside and outside the film

<sup>1</sup> Jour. Chem. Soc., 91, 2012 (1907); Zeit. Kolloidchemie, 7, 15 (1910).

<sup>2</sup> Cf. Jour. Phys. Chem., 16, 202 (1912).

are—or may be—the same, and the internal phase is the one exerting the most pressure, at any rate originally. With a real emulsion the conditions are different because we have two distinct liquids. It seems to me that it is easy to modify Donnan's theory so that it will fit the facts. Let us imagine a flexible, vertical diaphragm, which separates two liquids A and B, and which is wetted by each. Since the diaphragm by definition adsorbs each of the liquids, the surface tensions of the two sides of the wetted diaphragm will not be the same as a rule. Owing to this difference in the surface tensions, the diaphragm will bend so that the side with the higher surface tension becomes concave. This change tends to envelope the liquid on that side. Consequently we conclude that liquid A will form drops in the emulsion in case liquid B lowers the surface tension of the diaphragm more than does liquid A. The absolute and relative surface tensions of the two liquids against their respective vapors have nothing to do with the phenomenon and it is theoretically possible to emulsify benzene in water with one diaphragm and to emulsify water in benzene with another diaphragm. It all depends on the properties of the diaphragm, on the nature of the emulsifying agent. While this way of looking at the matter clears up the theoretical difficulties in regard to the type of emulsion, it is not quite clear from this how one would go to work to find a suitable emulsifying agent in any given case. I am quite willing to admit that I do not know how to formulate a rule which will cover all cases; but I can deduce one which covers a great many cases. Suppose we consider the extreme case that one of the two liquids, water for instance, lowers the surface tension of the diaphragm very much when adsorbed by it. We then have conditions favorable to the disintegration or peptonization of the diaphragm. Consequently we conclude that if a substance forms a colloidal solution with water and is coagulated by benzene, that substance will tend to emulsify benzene in water. To what extent we get an actual emulsion depends on the coherency and permanency of the film formed. This rule covers practically all the cases of

emulsions in water which have been considered in this series of papers. Soap is a hydrophile colloid and so are the gums. The insoluble salts used by Pickering approached the colloidal state the more finely they were ground, and it was under these conditions that they were the most effective. It is not possible from Pickering's experiments to tell to what extent the differences in effectiveness were due to the lack of formation of a suitably coherent film and to what extent they were due to specific relative adsorption. This point can be discussed more profitably when we get to the special case of ore flotation.

This formulation covers that of Höber,<sup>1</sup> previously quoted.<sup>2</sup> "Some other processes in the cell probably also come under the heading of adsorption of colloids. We saw that drops of chloroform or carbon bisulphide in solution of albumen become covered with a membrane of albumen. Such membranes, resulting from the contact of two solutions have been known in biology for a long time under the name of haptogen membranes. It is to them that we owe, in large part, the permanency of the emulsions which occur in many physiological solutions. Thus the continued, fine distribution of fat in milk is due to the existence of a film of caseine around the globule of fat. The emulsifying action of small amounts of alkali on a mixture of oil and water is due to the formation of membranes of soap at the surface between oil and water. In order to obtain a fine-grained emulsion it is not sufficient to add a substance which concentrates in the surfaces between two liquids. By addition of chloroform or acetone to oil and water, we get no emulsion. It is necessary that the added substance should be a hydrophile colloid which is adsorbed in its peculiar way with formation of a solid film."

Theoretically, it ought to be possible to form an emulsion when the emulsifying agent is soluble in water and is precipitated by the other liquid provided a film is formed; but it

<sup>1</sup> *Physikalische Chemie der Zelle und Gewebe*, third edition, 293 (1911).

<sup>2</sup> *Jour. Phys. Chem.*, 16, 227 (1912).



would be difficult to form a permanent emulsion unless one started with a saturated solution in water.

The theory as outlined shows that we should get an emulsion of water in oil or carbon bisulphide provided we took an emulsifying agent which formed a colloidal solution in the non-aqueous solvent. Instances of this have already been cited, rosin with linseed oil and water, lime soap with mineral oil and water. Using a magnesium soap plus a little sodium oleate Mr. F. R. Newman succeeded in emulsifying 90 percent of water in carbon bisulphide. The details of this work will be published by Mr. Newman at some future date.

There is one case cited by Pickering<sup>1</sup> which calls for special comment. He found that potassium cupric tartrate will emulsify a mixture of alcohol and water. Since alcohol and water are miscible in all proportions, this seemed a trifle uncanny until we repeated the experiment and found that potassium cupric tartrate causes aqueous alcohol to separate into two liquid layers. If anybody is interested in this special problem, it is evidently possible to make emulsions of acetone in water or of water in acetone by first adding some such salt as potassium carbonate to cause the formation of two liquid layers and then adding a suitable emulsifying agent.

Since the object of the emulsifying agent is to keep the drops of the dispersed phase from coalescing, anything which will act in this way will serve more or less as an emulsifying agent. As an extreme case we may have an electrical charge caused by the adsorption of an ion. Under these circumstances an emulsion will behave like a colloidal suspension. This has been realized by Ellis.<sup>2</sup> The interface potential was found to be little affected by organic impurities in the oil but to be altered enormously by acids, and to a lesser degree by alkalies. The maximum interface potential was found to correspond to a concentration of about N/1000 alkali, and this

<sup>1</sup> *Zeit. Kolloidchemie*, 7, 11 (1910).

<sup>2</sup> *Zeit. phys. Chem.*, 80, 597 (1912).

was found to be the point of maximum stability of the emulsion. Surface-tension measurements showed that the stability did not depend on the surface tension, but on the interface potential.

The question of the factors determining the stability of an emulsion is an important one from the point of view of the maker of emulsions; but it cannot be taken up in this series of articles because it depends on the theory of jellies. I propose to discuss it later under that head. A few words on the subject will suffice for the present. It is well known that jellies contract in time and exude liquid or even go all to pieces. If the surface film around the drops behaves in this way it is clear that the emulsion cannot be stable. Other things being equal an emulsion will be more stable, the smaller the drops. By use of a homogenizer it is possible to break up the globules in fresh milk so that the cream does not come out in a separator. I am told that it is also possible to start with skimmed milk and renovated butter fat, and to make an excellent imitation of fresh milk therefrom.

The general results of this paper are as follows:

1. Lanolin is an emulsion with water as the disperse phase.
2. Some of the properties of lubricating greases are due to the presence of emulsified water. The emulsifying agent is apparently the lime soap.
3. In mixed paints the water is the disperse phase. The emulsifying agent is apparently the dissolved rosin.
4. If the surface tension between liquid A and the emulsifying agent is lower than the surface tension between liquid B and the emulsifying agent, liquid A will be the dispersing and liquid B the disperse phase.
5. A hydrophile colloid will tend to make water the dispersing phase while a hydrophobe colloid will tend to make water the disperse phase.
6. In order to emulsify two liquids which are miscible in all proportions, it is necessary to add a substance which will make them only partially miscible.

7. As a limiting case, drops may be kept from coalescing by an electrical charge due to the adsorption of an excess of some ion. Such an emulsion will behave like a typical colloidal suspension.

8. Anything which destroys the film round the drops in an emulsion or which neutralizes the charge on the drops will make the emulsion less stable.

9. The cracking of an emulsion is often due to the ageing of the film round the drops. The discussion of this belongs properly under the theory of jellies and will be taken up there.

10. Other things being equal, an emulsion will be more stable, the smaller the drops.

In the next paper of the series I intend to consider the flotation of ores as a special case under the general theory of emulsification.

*Cornell University*

## DO MOLECULES ATTRACT COHESIVELY INVERSELY AS THE SQUARE OF THE DISTANCE?

BY ALBERT P. MATHEWS

In a very interesting and valuable recent paper in this journal by Mills,<sup>1</sup> the conclusion was drawn that the cohesive attraction of molecules varied inversely as the square of the distance. Besides this conclusion, which was founded on the interesting discovery that the internal latent heat of vaporization divided by the difference of the cube roots of the densities of the liquid and vapor was a constant, a most valuable part of the paper was the reopening of the question whether the field of molecular attraction is delimited by the surrounding molecules, or whether it owes its small size to the very rapid decrease of the attraction with the distance. This question raised a century ago by Laplace,<sup>2</sup> was answered by him in the latter sense without any convincing reason for his conclusion, and has not been reopened since, the opinion being almost universal that the shortness of the radius of action is due to the attraction diminishing with the distance at a rate far more rapid than the square; the fourth, fifth, seventh and even higher powers having been suggested. In thus reopening the question Mills has rendered a valuable service. That his conclusion is correct, that the molecular field is delimited by the surrounding molecules, is clearly indicated by Einstein's<sup>3</sup> calculation of the radius of action, showing that the radius is proportional to the distance between the molecular centers. The conclusion that the attraction is inversely as the square of the distance, however, I believe to be erroneous for the reasons which will be presented in this paper.

<sup>1</sup> Mills: *Jour. Phys. Chem.*, 15, 417 (1911).

<sup>2</sup> Laplace: "Traité de mécanique céleste," Supp. au Livre 10, p. 351.

<sup>3</sup> Einstein: *Drude's Ann.*, 34, 165 (1911).

Mills<sup>1</sup> discovered the empirical relationship that the quotient of the internal latent heat of vaporization divided by the difference of the cube roots of the densities of the liquid and vapor was a constant, except in the neighborhood of the critical temperature. If  $L$  is the total latent heat, and  $E$  is the part of it used in doing external work, then  $L - E$  would be the part of the heat used in doing internal work. He found that  $(L - E)/(d_l^{1/3} - D_v^{1/3}) = \mu'$ . He assumed that this internal heat was all used in overcoming molecular cohesion, and he ascribed the fall of the constant near the critical temperature to the inaccuracy of the data. He then reasoned that since for  $d_l^{1/3} - D_v^{1/3}$  the expression  $1/V_l^{1/3} - 1/V_v^{1/3}$  might be substituted, the molecules must attract each other inversely as the square of the distance; since it is only on such a supposition that the difference in potential energy of the molecules in the liquid and the vapor can be given by an expression of this kind. The similarity of his expression:  $L - E = \mu'(1/V_l^{1/3} - 1/V_v^{1/3})$  to Helmholtz's formula for the heat given off by the contraction of the sun seemed significant, the Helmholtz formula being  $W = \frac{3}{5}M^2K^2(1/R - 1/CR)$ . From this similarity Mills reasoned that molecular attraction, like gravitational, must follow the inverse square law. Since it is impossible that molecules should attract each other cohesively according to this law, if the cohesive attraction penetrated matter, he concluded that cohesion did not penetrate matter, but was delimited by the surrounding molecules.

There is, however, another relationship expressing the latent heat consumed in overcoming molecular cohesion or the internal pressure, which has been given by van der Waals and is derived from his expression for cohesive pressure of  $a/V^2$ . This relationship is:  $L - E = a(1/V_l - 1/V_v)$ ,<sup>2</sup> where

<sup>1</sup> Mills: Jour. Phys. Chem., 15, 417 (1911); Comptes rendus, 153, 193 (1911); Phil. Mag., [6] 22, 84 (1911); [6] 23, 484 (1912).

<sup>2</sup> This formula should, in my opinion, be written:  $L - E - X = a(1/V_l - 1/V_v)$  where  $X$  represents heat used in any other internal work than the separation of the molecules. See van der Waals: "Condensation of Gases," Encyclo. Britannica, xi edition. Also Sutherland: Phil. Mag., [5] 22, 83 (1886).

TABLE I—COMPARISON OF MILLS' CONSTANT "C" WITH "C'"  
 $C = (L - E) / (\sqrt{d} - \sqrt{D})$ ;  $C' = 3N^2MK / Wt^{1/2}V_c^{3/2}$

Temperature	C	C'	Temperature	C	C'
Ethyl acetate					
Methyl butyrate					
100°	$3.879 \times 10^{11}$		100°	$3.681 \times 10^{11}$	
200	3.915		200	3.643	
270	3.893		220	3.596	
280	3.416		240	3.461	
281.3	Critical	$3.442 \times 10^{11}$	247	3.324	
			249	3.329	
			250.1	Critical	$3.222 \times 10^{11}$
Diisobutyl					
100°	4.168		Ether		
180	4.114		0°	3.259	
200	4.148		20	3.216	
260	4.265		100	3.208	
274	4.113		180	3.158	
276.8	Critical	3.697	190	3.017	
			193	2.862	
			193.8	Critical	3.061

Methyl acetate		Methyl propionate	
100°	3.362	100	3.658
200	3.350	200	3.664
220	3.250	220	3.659
230	3.108	250	3.459
233	2.989	256	3.273
233.7	Critical	257.4	Critical
	3.064		3.251
Normal pentane		Benzene	
0°	3.354	80°	3.564
40	3.295	100	3.549
100	3.314	140	3.531
180	3.289	180	3.595
195	3.093	200	3.593
197.1	2.967	220	3.613
197.15	2.984	280	3.513
197.2	Critical	288.5	Critical
	3.181		3.471

TABLE 1. Critical Temperatures and Critical Pressures of Various Organic Compounds.

" $a$ " is van der Waals' constant. According to Sutherland<sup>1</sup> the latter expression indicates that the attraction of the molecules is inversely as the fourth power; whereas Mills has interpreted the former as meaning that it is inversely as the square.

To show how constant Mills' constant is, I have given, in Table 1, the results of the calculations by his formula of a number of substances from Young's data. The figures represent ergs for gram molecular quantities. It will be seen that the constancy is good for a considerable range of temperature, but that in all cases there is a more or less pronounced drop close to the critical temperature, and in some, as in ether and ethyl acetate, there is a pretty steady fall in the constant throughout. The fall near the critical temperature might be ascribed to errors of observation, or calculation. There is no doubt, therefore, that for most substances the expression  $(L - E)/(\sqrt[3]{d_1} - \sqrt[3]{D_v})$  closely approximates a constant except near the critical temperature, as Mills has pointed out.

The conclusion that this relationship shows that the molecules attract inversely as the square of the distance is, I believe, sound, if the premise is correct. The premise, or assumption, is that the internal latent heat of vaporization, or  $L - E$ , represents only the work done in separating the molecules against their molecular cohesion. While Mills' states in a recent paper that not all the internal heat may be used in doing this work, and attempts to show that this is not incompatible with this conclusion, the conclusion nevertheless depends on the assumption that it is so used and that there is no change in the internal energy of the molecules on passing from the liquid to the vapor. It is clear that if this premise be not true, then the conclusion does not follow.

This premise I believe to be certainly erroneous. It could only be true if the molecules remained of the same

<sup>1</sup> Mills: *Phil. Mag.*, [6] 22, 97 (1911); 23, 499 (1912).



size in liquid and vapor, or do not in other ways gain energy.<sup>1</sup> I believe the internal latent heat of vaporization consists of at least three parts, not two as is often stated, these three parts are: (1) the heat consumed in expanding against external pressure, or  $E$ ; (2), the heat consumed in overcoming molecular cohesion, or  $A$ ; (3), heat consumed in increasing internal molecular potential energy by expanding the molecule, or increasing its energy of rotation, or  $I$ . This last factor is often overlooked. If  $L$  is the total latent heat of vaporization the expression should be:  $L - E - I = A$ . And if molecules attract inversely as the square of the distance we should have  $(L - E - I)/(\sqrt[3]{d_e} - \sqrt[3]{D_v}) = \mu'$ .

There are two principal reasons why it cannot be assumed that all the internal latent heat of vaporization goes to increasing the potential energy by separating the molecules against the force of their molecular cohesions. The first of these reasons is that the value " $b$ ," of van der Waals' equation, has to be taken larger in the vapor than in the liquid for some distance below the critical point. And there are good reasons for thinking that " $b$ " represents the real volume of the molecules. The second reason is the value  $a/V^2$  representing cohesion in van der Waals' equation. A third reason has been given by Tyrer.

To show that the molecules actually do expand in passing from the liquid to the vapor, I have calculated the value of " $b$ " for pentane, and benzene using Young's data. I have also calculated several others of his substances, but as the result is similar in them to that in these two, I give only the latter in Table 2, which shows the value of  $b$  in cc in the liquid and vapor for gram molecular quantities  $b = V - RT/(P + a/V^2)$ .<sup>2</sup>

<sup>1</sup> A similar objection to Mills' conclusion has been raised by Professor Tyrer: *Phil. Mag.*, [6] 23, 112 (1912).

<sup>2</sup> Since sending this paper to the publisher I have found that the value of " $a$ " is larger than assumed here. This change requires  $b_e$  and  $b_v$  both to be larger. At 150°  $b_v$  should be about 127 cc and at 40° only 14. The relation between  $b_e$  and  $b_v$  is not greatly changed, but the difference between them becomes greater.

TABLE 2  
Pentane

$t$	$b_1$	$b_v$	$V_v$	P (At)	$a/V_v^2$
40°	100.6	-140	21,420	1.15	0.04
100	106.5	-64.1	4,428.00	5.80	1.09
150	114.6	79.9	1,512.60	15.54	8.72
180	124.2	140.3	790.05	25.46	31.96
190	130.8	151.9	567.36	29.61	61.90
195	137.2	155.2	447.5	31.91	99.55
197	144.5	153.3	359.10	32.90	154.70
197.2	149.4	149.4	309.94	33.03	207.50 (critical)

Benzene

$t$	$b_e$	$b_v$	$V_v$
80°	82.3	70	28,570
120	84.6	-170	10,160
160	87.4	22	5,428
200	90.8	52	2,200
240	96.2	89	1,093
260	100.5	110.3	751.7
270	103.6	120	606
280	108.2	127	470
288.5	123.8	123.8	256.2

Table 2 shows that, in pentane,  $b_v$  is larger than  $b_1$  from the critical temperature to about 160°. Below this point  $v_v$  falls rapidly and apparently soon becomes negative. The reason for this apparent fall is undoubtedly the association, or quasi-association, occurring in the vapor as the temperature falls, as van der Waals suggests, the result being that the number of the molecules in the space does not remain constant and hence  $R$  does not remain constant. The effect of reducing  $R$  to its real value, were we able to correct for the association, would be to make  $b_v$  larger. In benzene  $b_v$  falls below  $b_1$  sooner than in pentane, from which we may infer that the association in benzene is a little larger than in pentane. The apparently negative value of  $b_v$  is found closer to the critical temperature in the esters which are known to associate slightly. Since association produces an

apparent decrease in  $b_v$ , it is practically certain that the differences between  $b_1$  and  $b_v$  are actually larger than those indicated. The main fact is then established that  $b_v$  is actually larger than  $b_1$  for some degrees below the critical point in spite of the association which tends to mask the actual molecular expansion and which, at lower temperatures, conceals it entirely.

It will be seen, also, that, as one would expect,  $b_v$  actually decreases close to the critical temperature, owing to the compression of the molecules due to the great increase in internal and external pressure. This increase of pressure ( $P + a/V^2$ ) is indicated in Table 2 in the case of pentane, the pressures being given in atmospheres per sq. cm.

It is of interest, in this connection, to compute what is possibly the real value of  $b_v$ , making van der Waals' assumption that in the vapor, at low temperatures,  $b_v$  is equal to  $2b_1$ . Supposing that this is the case at absolute zero we may write the rectilinear diameter formula:  $b_1 + b_v = b_c ((3T_c + T)/2T_c)$ . This assumes that at absolute zero the molecules are so compressed that in the solid their volume is one-half of what it would be in the vapor at the same temperature, and that the volume of the vapor molecules at absolute zero is that of  $b_c$ .  $b_c$  is very nearly  $V_c/2$ . Table 3  $b_v = b_c((3T_c + T)/2T_c) - b_1$ .

TABLE 3  
Pentane

$t$	$b_1$	$b_v$ (cal)	$b_v$ (taken from Table 2)
40°	100.6	173.2	-140
100	106.5	176.9	-64.1
150	114.6	176.7	79.9
180	124.3	171.9	140.3
190	130.8	166.8	151.9
195	137.2	161.3	155.2
197	144.5	154.3	153.3
197.2	149.4	149.4	149.4

The parabola represented by these figures is given in Fig. 1. If there is any association in the liquid the effect

of correcting for it would be to reduce the value of  $b_v$  and increase  $b_1$  and so to make the parabola flatter. I have computed  $b_1$  assuming that there is no association in the liquid. The increase of  $b_v$  with the temperature is seen to be very slight. From absolute zero to the maximum value at  $100^\circ$  the increase is at the rate of 0.074 cc per degree for gram mol quantities. On the other hand " $b$ " changes markedly with the pressure.

There are several reasons for believing that " $b$ " is the real volume of the molecules and not four times the volume as was originally suggested. One is that " $b$ " at the critical

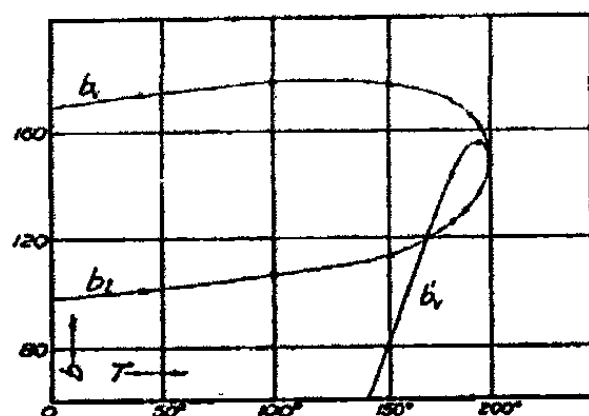

Fig. 1—Volumes of molecules ( $b$  for gram mol quantities in cc.) for pentane.  $b_1$  calculated from formula  $b_1 = V_1 - RT/(P + a/V_1^2)$  assuming no association;  $b_2$  calculated by formula:  $b_2 = b_c((3T_c + T)/2T_c)$ ;  $b_3$  apparent volume of  $b_2$  by formula:  $b_3 = V_2 RT/(P + a/V_2^2)$  assuming no association.

temperature is very nearly  $V_c/2$  and this is just twice the volume at absolute zero. It is unlikely that the molecules do not expand in passing from absolute zero to the critical temperature, since at the former temperature they are under a pressure of 3572 atmospheres in pentane, whereas at the critical temperature the pressure is only 240 atmospheres. It would take very little separation of the atoms to double the volume.

The latent heat shows, also, that heat is absorbed by the molecule roughly proportional to the number of atoms in the molecule. This would mean that the atoms vibrated (or expanded) and they must hence take up more space as the vigor of vibration increases. This would seem to be sufficient

to account for doubling the volume of  $b$  between  $0^\circ$  Abs. and  $T_c$ . Van der Waals' himself only assumed the constancy of the molecular volume " $b$ " for simplicity, and has now definitely adopted the idea of a change in volume of the molecules. He has obtained, by making certain assumptions, the following expression for the change of " $b$ ," the molecular volume:  $(b - b_0)/(V - b) = 1 - (b - b_0)^2/(b_0 - b_0)^2$ . In this equation  $b_0$  and  $b_0$  are the limiting values of  $b$ ;  $b_0$  at low vapor pressures, and  $b_0$  under high pressure; the actual value under any temperature and pressure is " $b$ ." Van der Waals assumes that in liquids at low temperatures,  $b_0 = 2b_0$ . Both probability and direct observation lead, therefore, to the conclusion that the molecules expand on passing from the liquid to the vapor state.

It is clear that if the molecules do thus expand against the great force of atomic affinity, or intra-molecular cohesion, some heat must be absorbed. The quantity thus absorbed will probably be greatest at low temperatures, where there is a maximum difference in cohesive pressure between the liquid and the vapor, and will diminish rapidly near the critical temperature, since the volumes of the molecules in the two states approach each other and become equal at the critical temperature. As we near the critical temperature, therefore, the value of  $I$  will become very small, and the equation  $L - E = A$  will become very nearly true.

The second reason why the internal latent heat of vaporization can not be assumed to go altogether to increasing the distance between the molecules is the fact that the internal pressure, the cohesive pressure, is inversely proportional to the square of the volume. For, assuming as before that all the latent heat goes toward separating the molecules, if  $a/V^2$  is the cohesive pressure per unit surface then the cohesive energy in the liquid will be  $a/V_l$ ; and in the vapor,  $a/V_v$ ; and the difference in their cohesive energies will be

<sup>1</sup> Van der Waals: "The Liquid State and the Equation of Condition," Proc. Roy. Acad. Sci. Amsterdam (English Translation), 6, 123 (1903).

$a(1/V_1 - 1/V_v)$ . By our assumption this difference in energy must be equal to  $L - E$ . Hence  $(L - E)/(1/V_1 - 1/V_v)$  must equal "a." We come, therefore, to an expression different from Mills and one incompatible with it. Since it is certain that the cohesive pressure varies at least approximately inversely as the square of the volume this expression must be the correct expression, if  $L - E$  represents only heat consumed in overcoming cohesion. As a matter of fact  $(L - E)/(1/V_e - 1/V_v)$  does not equal a constant, hence our assumption must be wrong. But if the assumption is wrong then the fact that  $(L - E)/(1/V_1^{1/3} - 1/V_v^{1/3})$  happens to equal a constant can not be adduced as evidence that molecules attract inversely as the square of the distance.

I think therefore, that Mills' empirical expression,  $L - E = \mu'(1/V_1^{1/3} - 1/V_v^{1/3})$  does not mean, as he supposed, that the work done in overcoming molecular cohesion from the volume  $V_1$  to the volume  $V_v$  was equal to  $\mu'(1/V_1^{1/3} - 1/V_v^{1/3})$ , but that the total internal latent heat, *i. e.*, that used in overcoming molecular cohesion as well as that absorbed in the expansion of the molecules, or in doing other work is equal to this expression.

That Mills' expression,  $\mu'(1/V_1^{1/3} - 1/V_v^{1/3})$ , does not represent the work done in overcoming molecular cohesion may be shown, also, if the attempt is made to deduce the formula on this basis, assuming the attraction to vary inversely as the square of the distance. A value is obtained for  $\mu'$  widely different from that found. Mills realized this difficulty and tried to avoid it by assuming that the law that matter attracted itself as the product of the masses was incorrect.

I will make the simplest possible assumptions. If the molecules are assumed to be cubical in shape, to lie a mean distance apart and the lines of attractive force to run perpendicularly from each face of the cube in three directions of space and to end upon the six surrounding molecules, but not to penetrate them; and if the molecules attract with a force varying inversely as the square of the distance between

the centers and directly as the product of the cohesive masses  $M$ , then the attraction of two molecules would be  $M^2K/v^{2/3}$ . The pressure per square cm would be  $M^2K/v^{1/3}$ . Since the attraction goes but a single molecular diameter we may multiply the numerator and denominator by  $N^{1/3}$ , where  $N$  is the number of molecules in the mass which will make  $N^{1/3}M^2K/V^{1/3}$ . It is obvious that this expression cannot be true, for the cohesion varies inversely as the square of the volume, and not as the  $4/3d$  power. Assuming, however, that it is correct we would have, as the difference in the cohesive energies in the liquid and vapor, the expression:  $N^{1/3}M^2K(1/V_1^{1/3} - 1/V_v^{1/3})$ . Or changing to density  $N^{1/3}M^2K(d_1^{1/3} - D_v^{1/3})/Wt^{1/3}$ . Hence  $L - E$  should equal this expression, and  $(L - E)/(d_1^{1/3} - D_v^{1/3}) = N^{1/3}M^2K/Wt^{1/3} = \mu'$ . This last expression can be tested, since  $M^2K$  can be easily computed from van der Waals "a" by dividing it by  $N^2$ , the square of the number of molecules in the volume  $V$ , or  $Wt$ ; and  $\mu'$  is given by Mills. The two values are not of the same order of magnitude. For example in pentane,  $\mu'$  is 110, whereas  $N^{1/3}M^2K/Wt^{1/3}$  for 1 gram is  $2.214 \times 10^{-18}$  calories. A constant very like  $\mu'$  is obtained, however, if the foregoing constant is divided by  $V_c^{2/3}/3N^{2/3}$ . This changes it to the expression  $3N^2M^2K/V_c^{2/3}Wt^{1/3}$ . This would give the value 102 for pentane. How closely this constant agrees with Mills is shown in Table 1.  $N^2M^2K$  is equal to "a."

The constant cannot be deduced, therefore, by the assumptions we have made, one of them being that molecules attract each other inversely as the square of the distance, but it is necessary to divide the theoretical constant by  $V_c^{2/3}/3N^{2/3}$  to get that found. This however, has the effect of changing the equation, near the critical temperature, to the form:  $L - E = 3a(1/V_1 - 1/V_v)$  which is almost identical with van der Waals.

This argument will perhaps be still more convincing if it be turned around. Let us suppose Mills' contention is correct and the internal latent heat represents only heat used in overcoming cohesion, then  $\mu'/V_1^{1/3}$  is the cohesive energy

in the liquid; and  $\mu'/V_v^{1/3}$  is that in the vapor. If now we divide the first by  $V_l$  and the second by  $V_v$  we obtain the cohesive pressure per unit surface in the liquid and vapor, respectively, or  $\mu'/V_l^{1/3}$  and  $\mu'/V_v^{1/3}$ . But we know that the cohesive pressure is  $a/V^2$ , hence the original assumption must be incorrect.

If, on the other hand, the difference in the cohesive energy in the liquid and vapor is equal to  $a(1/V_l - 1/V_v)$ , and all the latent heat is used in overcoming external and cohesive pressure, then  $L - E$  should equal this expression. If, however, some of the heat,  $I$ , is used in expanding the molecules then the equation should be:  $L - E - I = a(1/V_l - 1/V_v)$ . Near the critical temperature  $I$  becomes very small and hence  $(L - E)/(d_l - D_v)$ , near the critical temperature, must be very nearly equal to  $a/Wt$ , where  $Wt$  is the weight taken in grams; but at temperatures below the critical,  $(L - E)/(d_l - D_v)$  should be progressively greater than  $a/Wt$  by the amount  $I/(d_l - D_v)$ . Table 4 shows that this expectation is realized, since in all cases the value  $(L - E)/(d_l - D_v)$  is greater below the critical temperature, but becomes very nearly equal to  $a/Wt$  at the critical temperature. The value " $a$ " used in these calculations was calculated from the surface tension in the manner described.<sup>1</sup>

The values diverge as the temperature falls.

TABLE 4—ERGS FOR GRAM MOLECULAR QUANTITIES  
Diisobutyl                      Methyl acetate

Temp.	$\frac{L-E}{d-D}$	$\frac{N^2M^2}{K/Wt}$	Temp.	$\frac{L-E}{d-D}$	$\frac{N^2M^2}{K/Wt}$
—	—		100°	$3.025 \times 10^{11}$	
100°	$4.768 \times 10^{11}$		200	2.597	
200	4.238		220	2.414	
260	3.942		230	2.243	
274	3.660		233	2.124	
276.8	Critical	3.222	233.7	Critical	2.160

<sup>1</sup> Mathews: Jour. Phys. Chem., 17, 154 (1913).



TABLE 4—(Continued)

Diisopropyl			Ethyl acetate			
Temp.	$\frac{L-E}{d-D}$	$\frac{N^2M^2}{K/Wt}$	Temp.	$\frac{L-E}{d-D}$	$\frac{N^2M^2}{K/Wt}$	
100°	$3.808 \times 10^{11}$	2.877	100°	3.462	2.357	
200	3.291		200	3.016		
220	3.039		220	2.873		
225	2.895		240	2.645		
227.35	Critical		247	2.482		
			249	2.472		
		250.1	Critical			
Methyl propionate			Methyl formate			
100°	$3.417 \times 10^{11}$	2.353	100°	$2.481 \times 10^{11}$		1.791
200	3.030		200	2.015		
220	2.931		210	1.842		
250	2.598		213	1.747		
256	2.396		213.5	1.710		
257.4	Critical		214	Critical		
Pentane normal			Stannic chloride			
0°	$4.013 \times 10^{11}$	2.806	100°	$1.573 \times 10^{11}$	1.106	
40	3.807		200	1.413		
100	3.558		240	1.358		
180	3.085		260	1.322		
195	2.769		280	1.280		
197.1	2.621		318.7	Critical		
197.15	2.637					
197.2	Critical					
Ethyl propionate			Propyl acetate			
100°	$3.901 \times 10^{11}$	2.552	100°	3.929	2.575	
200	3.385		200	3.507		
270	2.825		270	2.860		
272.8	Critical		275	2.721		
			276.2	Critical		
Benzene			Ethyl formate			
80°	$3.486 \times 10^{11}$	2.556	100°	$2.968 \times 10^{11}$	2.121	
100	3.413		200	2.532		
140	3.272		230	2.201		
180	3.197		234	2.087		
200	3.118		235.3	Critical		
220	3.052					
280	2.676					
288.5	Critical					

TABLE 4—(Continued)

Isopentane			Methyl butyrate		
Temp.	$\frac{L-E}{d-D}$	$\frac{N^2M^2}{K/Wt}$	Temp.	$\frac{L-E}{d-D}$	$\frac{N^2M^2}{K/Wt}$
20°	$3.694 \times 10^{11}$		100°	3.776	
100	3.367		200	3.429	
160	3.067		270	3.033	
185	2.694		280	2.573	
187	2.616		281.3	Critical	2.559
187.4	2.559				
187.8	Critical	2.726			
Heptane			Methyl isobutyrate		
0°	5.045		100°	3.675	
100	4.730		200	3.256	
180	4.314		265	2.687	
220	4.114		266.5	2.620	
260	3.668		267.55	Critical	2.488
266	3.428				
266.5	3.343				
266.85	Critical	3.187			
Ether			Carbon tetrachloride		
0°	3.596		0°	1.907	
20	3.481		80	1.823	
100	3.160		100	1.792	
180	2.708		120	1.756	
190	2.516		180	1.661	
193	2.332		200	1.590	
193.4	Critical	2.468	260	1.520	
			280	1.419	
			283.15	Critical	1.383
Hexane			Fluorbenzene		
0°	4.504		80°	3.096	
80	4.217		200	2.672	
100	4.128		286.55	Critical	2.391
180	3.684				
200	3.568				
234	3.004				
234.8	Critical	3.003			

It is of interest to see how large the amount of heat (I) is which is absorbed intramolecularly on passing from liquid to vapor. Table 5 contains the calculations for I of 1 gram of hexane.  $I = L - E - a(1/V_1 - 1/V_v)$  gram calories.

TABLE 5—HEXANE

$t$	L—E	I
0°	84.68	28.21 Calories
60	73.59	21.88
80	70.04	20.17
100	65.82	18.06
180	44.30	8.19
200	37.00	5.86
230	16.98	0.93
234	8.98	0.00
234.5	0.00	0.00 Critical

The intramolecular heat (I) absorbed is obviously considerable.<sup>1</sup> At corresponding temperatures the amount of intramolecular latent heat is for gram mol quantities, greater, the larger the number of atoms in the molecule as may be seen in Table 4.

The conclusion is, therefore, that van der Waals' relationship, *i. e.*,  $L - E = a(1/V_1 - 1/V_v)$  is correct close to the critical temperature, but should be changed to the form  $L - E - I = a(1/V_1 - 1/V_v)$ , where I is the heat made latent intramolecularly by expansion of the molecules, or increasing rotation, in passing from the liquid to the vapor; and that while Mills relationship:  $L - E = \mu'(1/V_1^{1/3} - 1/V_v^{1/3})$  is empirically true except, possibly, near the critical temperature, yet since  $L - E$  does not represent solely the increase in potential energy due to the separation of the molecules, the inference he has drawn from it, that molecules attract inversely as the square of the distance, is not justified. On the other hand, the correct expression for the increase of molecular potential energy,  $a/(1/V_1 - 1/V_v)$ , is obtained very simply if the molecules attract inversely as the fourth power of the distance, as Sutherland has shown.

University of Chicago

<sup>1</sup> "a" should be larger and the figures in column 3 should be somewhat smaller. See footnote p. 525.

## INDIRECT ANALYSIS OF A FERRIC OXIDE GEL

BY HARRY B. WEISER

In a paper by Professor Bancroft<sup>1</sup> a method was given for the indirect analysis of a solid phase containing any number of components, without the removal of this solid phase from the mother liquor. The method consists in determining the composition of the original solution in terms of all the various components and then determining the composition of the mother liquor in terms of the same components after the separation of the solid. From the values so obtained it is possible to calculate the composition of the solid phase, providing one, at least, of the components does not form a part of it. To calculate the composition of the phase from the data, the amounts of the various components before and after precipitation are expressed in terms of unit amount of the substance that does not enter into the solid phase. The difference between the values before and after precipitation gives the relative amounts of each of the components present in the separated phase.

In order for this method to be generally applicable, it is evident that certain conditions must obtain:

1. There must be an appreciable difference between the initial and final concentrations.
2. It must be possible to analyze accurately for all components.
3. The solid phase must separate and settle so as to leave a comparatively clear supernatant liquor.
4. One, at least, of the components must not form a part of the solid phase.

Part I.—Method of *indirect analysis* of a gel, in which one component of the system from which it separates does *not* enter into the solid phase.

It may be desired to find out the exact composition of a

---

<sup>1</sup> Jour. Phys. Chem., 9, 558 (1905).

gelatinous precipitate that cannot be removed from the mother liquor and determined accurately in the ordinary way. As an example of how this may be done in a specific case by the indirect method above given, an analysis was made of the gelatinous ferric hydroxide obtained by adding caustic soda to a ferric chloride solution.

Lachs and Michaelis<sup>1</sup> found that chlorine ion is not adsorbed at all by blood charcoal in the presence of an excess of caustic soda. From the result of their investigation it was thought that perhaps chlorine would not be adsorbed by gelatinous ferric hydroxide when the latter was precipitated from ferric chloride solution with an excess of sodium hydroxide. If we assume, then, that no chlorine is adsorbed in the presence of an excess of caustic soda, we have at hand all the above conditions for ready analysis of a ferric hydroxide gel.

#### Experimental

1. A solution of ferric chloride was made up and the amount of iron and chlorine in unit weight of this solution determined.
2. A solution of caustic soda was prepared and the strength per unit weight determined by titration with standard acid.<sup>2</sup>
3. To a weighed amount of the ferric chloride solution a considerable excess of caustic soda solution was added and the precipitated phase allowed to settle.
4. Portions of the clear supernatant liquid were pipetted off and analyzed for chlorine and alkali per unit weight.
5. The composition of the gelatinous ferric hydroxide was calculated from the data so obtained, assuming that no chlorine is adsorbed.

<sup>1</sup> Lachs and Michaelis: *Zeit. Elektrochemie*, 17, 2, 917 (1911).

<sup>2</sup> It was found in connection with this work that the sodium hydroxide used contained about 2.5 percent of sodium chloride, so that the caustic soda solution had to be analyzed for this impurity per unit weight and the correction made when the composition of the original solution before mixing, was expressed in terms of the various constituents: iron, sodium, hydroxyl, etc.

DETERMINATION No. 1 (1)

Constituents	Fe	Cl	OH	Na <sup>+</sup>	H <sub>2</sub> O
Composition of 1000 grams of solution before mixing	2.3212	4.4649	5.3349	7.3139	979.5993
Composition of 1000 grams of solution after mixing	0.0000	4.5818	3.1143	7.1482	985.2357
Composition before mixing calculated (2)	519.89	1000.00	1194.86	1638.11	219400
Composition after mixing calculated (2)	0.00	1000.00	691.76	1587.85	218630
Difference = gel (3)	519.89	0.00	503.10	50.26	770
Expressed as Equivalents					
Composition of 1000 grams of solution before mixing	0.4152	0.12590	0.31367	0.31731	54.3769
Composition of 1000 grams of solution after mixing	0.0000	0.12699	0.18310	0.31011	54.6870
Composition before mixing calculated (2)	9.301	28.208	70.25	71.06	12179
Composition after mixing calculated (2)	0.000	28.208	40.67	68.89	12135
Difference = gel (3)	9.301	0.000	29.58	2.17	44

Formula Fe<sub>2</sub>O<sub>3</sub>, 0.468 NaOH, 12.08 H<sub>2</sub>O

(4) Percent error = 1.6 percent

(5) NaOH added 27.464 grams  
NaOH required 10.976 grams  
NaOH in excess 16.488 grams

A further correction must be made in the hydroxyl content of the solution before the separation of the solid phase. Since analysis shows that the ferric chloride solution employed is not pure ferric chloride but contains slightly more iron than would correspond to the formula  $\text{FeCl}_3$ , a calculated increment of hydroxyl is added to the value obtained by analysis, in order to correct for the slight excess of iron in the ferric chloride solution. This correction is a small one, in "Determination No. 1," it is approximately 0.000002 of an equivalent of hydroxyl in a gram of solution.

In the above table as well as the similar ones following, certain explanations are necessary:

(1) In order to do away with so many decimal places and so facilitate tabulation, unit amount is taken as 1000 instead of 1. Thus the composition of 1000 grams of the solution before and after mixing is given, instead of the composition of 1 gram.

(2) "Calculated" values, express the composition of the solution in terms of unit amount (1000 grams) of chlorine.

(3) "Difference" gives the relative amounts of the various constituents present in the gel on the assumption that no chlorine is carried down. The formula is then calculated from these relative values.

(4) The "percent error" was calculated from the fact that the anion and cation concentration differed slightly. Thus in Determination No. 1

Fe =	$3 \times 9.301$	=	27.903
Na =		=	2.170
Cations =		=	30.073
Anions (OH) =		=	29.580
			0.493
Error =		=	0.493 = 1.6 percent

(5) The sodium hydroxide solution used contained 0.04660 gram of NaOH per gram of solution.

## DETERMINATION NO. 2

Constituents	Fe	Cl	OH	Na	H <sub>2</sub> O
Composition of 1000 grams of solution before mixing	2.2829	4.4036	5.5735	7.6442	980.1291
Composition of 1000 grams of solution after mixing	0.0000	4.4364	3.3890	7.4780	984.6966
Composition before mixing calculated	517.13	1000.00	1265.66	1715.88	222570
Composition after mixing calculated	0.00	1000.00	763.91	1685.60	222180
Difference = gel	517.13	0.00	501.75	50.28	390

## Expressed as Equivalents

Composition of 1000 grams of solution before mixing	0.04084	0.12453	0.32770	0.33166	54.4037
Composition of 1000 grams of solution after mixing	0.00000	0.12514	0.19925	0.32873	54.6567
Composition before mixing calculated	9.274	28.208	74.42	75.31	12354
Composition after mixing calculated	0.000	28.208	44.91	73.12	12332
Difference = gel	9.274	0.00	29.51	2.19	22

Formula  $\text{Fe}_2\text{O}_3, 0.472 \text{ NaOH}, 7.68 \text{ H}_2\text{O}$

Percent error = 1.6 percent

NaOH added

29.386

NaOH necessary

11.054 grams

NaOH in excess

17.732 grams



DETERMINATION No. 3

Constituents	Fe	Cl	OH	Na	H <sub>2</sub> O
Composition of 1000 grams of solution before mixing	2.3353	4.4878	5.2468	7.1927	980.7693
Composition of 1000 grams of solution after mixing	0.0000	4.5064	3.0138	7.0149	985.4649
Composition before mixing calculated	520.34	1000.00	1169.12	1602.70	218550
Composition after mixing calculated	0.00	1000.00	668.77	1556.25	218680
Difference = gel	520.34	0.00	500.35	46.45	-130

Expressed as Equivalents

Composition of 1000 grams of solution before mixing	0.04178	0.12660	0.30849	0.31205	54.4393
Composition of 1000 grams of solution after mixing	0.00000	0.12965	0.17719	0.30433	54.6993
Composition before mixing calculated	9.306	28.208	68.74	69.53	12131
Composition after mixing calculated	0.000	28.208	39.32	67.53	12138
Difference = gel	9.306	0.00	29.42	2.00	-7

Percent error 1.6 percent

NaOH added 26.927 grams

NaOH required 11.015 grams

NaOH in excess 15.912 grams

## DETERMINATION No. 4

Constituents	Fe	Cl	OH	Na	H <sub>2</sub> O
Composition of 1000 grams of solution <i>before mixing</i>	2.3345	4.4870	5.2517	7.1997	980.7617
Composition of 1000 grams of solution <i>after mixing</i>	0.0000	4.5033	3.0282	7.0351	985.6334
Composition <i>before mixing</i> calculated	520.28	1000.00	1170.43	1604.54	218600
Composition <i>after mixing</i> calculated	0.00	1000.00	672.44	1562.20	218800
Difference = gel	520.28	0.00	497.99	42.34	-200
Expressed as Equivalents					
Composition of 1000 grams of solution <i>before mixing</i>	0.04176	0.12656	0.30878	0.31235	54.4383
Composition of 1000 grams of solution <i>after mixing</i>	0.00000	0.12694	0.17804	0.30521	54.7088
Composition <i>before mixing</i> calculated	9.307	28.208	68.82	69.61	12133
Composition <i>after mixing</i> calculated	0.000	28.208	39.53	67.78	12144
Difference = gel	9.307	0.00	29.29	1.83	-11
Percent error 1.3 percent					
NaOH added	NaOH necessary	NaOH in excess			
27.010 grams	11.031 grams	15.979 grams			

DETERMINATION NO. 5

Constituents	Fe	Cl	OH	Na	H <sub>2</sub> O
Composition of 1000 grams of solution <i>before</i> mixing	2.7777	5.1957	2.4910	3.3808	986.2955
Composition of 1000 grams of solution <i>after</i> mixing	0.0000	5.0909	0.0000	3.3147	991.5944
Composition <i>before</i> mixing calculated	534.61	1000.00	479.45	650.69	189827
Composition <i>after</i> mixing calculated	0.00	1000.00	0.00	651.10	194720
Difference = gel	534.61	0.00	479.45	-0.41	-4893

Expressed as Equivalents

Composition of 1000 grams <i>before</i> mixing	0.4965	0.14656	0.14646	0.14667	54.7455
Composition of 1000 grams <i>after</i> mixing	0.00000	0.14734	0.00000	0.14734	54.9943
Composition <i>before</i> mixing calculated	9.564	28.208	28.18	28.23	10537
Composition <i>after</i> mixing calculated	0.000	28.208	0.00	28.25	10820
Difference = gel	9.564	0.00	28.18	-0.02	-283

Percent error 1.6 percent  
 NaOH added 9.925 grams      NaOH required 10.150 grams      Deficiency of NaOH 0.225 gram

The above four determinations, made under similar conditions show the method that may be employed in determining and calculating the composition of a gel providing one of the components of the system from which it separates does not form a part of it.

An examination of the composition of the gelatinous ferric hydroxide, as determined under the assumption that no chlorine is adsorbed shows that little or no water is carried down by the gel. This is contrary to what we should expect and indeed contrary to observed facts since a ferric hydroxide gel centrifuged until it is firmly matted together, shrinks and loses appreciable amounts of water on standing. Indeed in "Determinations 3 and 4," the amount of water expressed in terms equivalent to 1 gram of chlorine is greater after precipitation than it was before. The only logical explanation of this anomaly is that, even in the presence of an excess of caustic soda, chlorine is adsorbed by gelatinous ferric hydroxide. If the amount of chlorine as found by analysis of the mother liquor is less than it should be, *i. e.*, if some chlorine is adsorbed, it is evident from the tables above that this would cause a considerable error in the determination of the water as well as of the sodium present in the gel. To show this effect even more strikingly an analysis was made in which just a trifle *less* sodium hydroxide was added than the amount necessary. In such a case there is certain to be considerably more chlorine adsorbed than in the above cases where a considerable excess of sodium hydroxide is present. As can be seen from Table V, in which the result of this analysis is given, the water content of the gel is quite appreciably negative. Such an erroneous result is obtained because the calculations have been made under an erroneous assumption, for chlorine is unquestionably adsorbed in every case. The values obtained for the composition of the ferric hydroxide gel in each specific case are of course entirely wrong, since they are calculated on the basis of an assumption that the experiment at hand shows to be erroneous. However, the method is a general one and may be used with quantitative exactness

in the analysis of a gel, providing *all* of the conditions stated at the beginning of this paper are met. In the case under consideration all of the components of the system enter into the solid phase so that the above method is inapplicable.

Part II.—Method of indirect analysis of a gel in which all the components of the system from which it separates, enter into the *solid phase*.

The next question that naturally presents itself is whether it would be possible by indirect analysis to determine the composition of a gel, when all of the components of the system from which it separates enter in. As will be shown, this may be done accurately under certain conditions.

Let us assume that we are dealing with the components A, B, C, and D. In the solution before precipitation then, there will be X grams of A, Y grams of B, Z grams of C and W grams of D. If now the gel will settle firmly to the bottom, or if it can be made to settle to a firm homogeneous mass by centrifuging in a cylindrical graduate so that the volume of the supernatant liquid can be read, it is possible to determine the exact amount of the various constituents in all the mother liquor, thus:

1. After the gel has been consistently matted together, read the volume of the supernatant liquid.

2. Determine the density of the mother liquor with a pycnometer.

3. Pipette off portions and determine the amounts of the various constituents per unit weight of the solution.

4. From the volume, density and composition per unit weight, calculate the amount of each constituent in all of the mother liquor. The result will be X' grams of A, Y' grams of B, Z' grams of C and W' grams of D. The difference between the original and final amounts of the various constituents gives the amount of each present in the solid, thus:

Composition of original solution, X gram A + Y gram B + Z gram C + W gram D

Composition of liquor after prec., X' gram A + Y' gram B + Z' gram C + W' gram D

Solid phase,  $X - X'$  gram A +  $Y - Y'$  gram B +  $Z - Z'$  gram C +  $W - W'$  gram D

From the above discussion it is evident that when all the components enter into the solid phase, the same conditions before given as regards initial and final concentrations, possibility of accurate analysis, etc., must obtain. In addition the solid must be of such a nature that it may be made to mat together in a compact homogeneous mass, so that the volume of the mother liquor may be accurately read.

Gelatinous ferric hydroxide prepared by precipitation of a ferric chloride solution with caustic soda, was found to fit all of the necessary conditions admirably, so that the above method could be employed readily for accurately determining its composition in any given case. It was even found by vigorous centrifuging for some hours that the gel was matted down sufficiently firmly to allow the mother liquor all to be poured off without stirring up a particle of the solid. In the interest of greater accuracy this latter procedure was followed, since, if correction is made for incomplete drainage, the weight of the mother liquor could be more accurately determined with the balance, than by volume-density determinations.

#### Experimental

Solutions of ferric chloride and caustic soda were made up as before given and the strength of each per unit weight in terms of the various constituents was found. To a known weight of the ferric chloride solution in a cylindrical graduate, a known amount of caustic soda was added and then put into a centrifuge and centrifuged at the rate of 1000 r. p. m. until the gel was pressed as a solid mass into the bottom of the cylinder. It was assumed that the process was complete, when continuous centrifuging for 2 hours caused no further diminution in the mass of the gel. The mother liquor was then poured off and weighed (correction being made for incomplete drainage) and the exact total composition determined in terms of the five constituents. These values subtracted from the values representing the initial composition give the composition of the gel. The analysis follows:

DETERMINATION NO. I

Composition	Total weight	Fe	Cl	OH	Na	H <sub>2</sub> O
Original solution	86.934	0.23637	0.44837	0.24559	0.33886	85.6648
Mother liquor	81.456	0	0.41599	0.02596	0.30567	80.7184
Gel	5.468	0.23637	0.03238	0.21963	0.03319	4.9464
Formula Fe <sub>2</sub> O <sub>3</sub> , 0.432 NaCl, 0.247 NaOH, 132.8 H <sub>2</sub> O NaOH used NaOH necessary NaOH in excess 12.410 grams 10.903 grams 1.507 grams						

In this determination the amount of sodium hydroxide was slightly in excess of the amount necessary. Under such conditions we would expect the adsorption of chlorine to be quite appreciable. The above analyses shows this to be true. Other analyses were made in which the excess of sodium hydroxide used was considerably more. The results are given on pp. 549-550.

These determinations show the composition of the gelatinous ferric hydroxide under the conditions which prevail in each individual case. Chloride, alkali and water are all three found to be present, but the composition is not constant—the relative amounts of each constituent varying among themselves. This is exactly as we should expect, since the composition of a gel of this kind is certain to be influenced to a greater or lesser degree by the conditions obtaining in each specific case. The chief factors influencing the composition of the gel under consideration are:

I. The concentration of chlorine ion in the final solution.

II. The amount of caustic soda added in excess of the theoretical amount necessary.

III. The length of time of standing after precipitation.

Generally speaking, the greater the concentration of chlorine ion in the final solution, the more would be carried down by the gel. If this were the only factor that influenced the amount of chlorine adsorption, we should expect it to be constant in all cases in which the final concentration of the solution with reference to chlorine ion, was constant. But this is not the only factor that influences the chlorine adsorption. The caustic soda concentration also has an effect. The following table will show this. In this table are brought together for comparison the several formulae of the gelatinous ferric hydroxide obtained above, under different conditions as regards chloride and alkali concentrations.

Under the heading, "Excess of NaOH used," is placed the number of grams of sodium hydroxide solution (0.0466



DETERMINATION No. 2

Composition	Total weight	Fe	Cl	OH	Na	H <sub>2</sub> O
Original solution	99.979	0.19922	0.29205	0.57663	0.79564	98.0155
Mother liquor	95.236	0	0.37477	0.36907	0.74389	93.7483
Gel	4.743	0.19922	0.01728	0.20736	0.05175	4.2672
Formula Fe <sub>2</sub> O <sub>3</sub> , 0.273 NaCl, 0.986 NaOH, 136 H <sub>2</sub> O NaOH used NaOH necessary NaOH in excess 29.139 grams 9.189 grams 19.950 grams						

DETERMINATION No. 3

Composition	Total weight	Fe	Cl	OH	Na	H <sub>2</sub> O
Original solution	97.731	0.18845	0.37323	0.60791	0.83879	95.7226
Mother liquor	93.084	0	0.35630	0.40671	0.78263	91.5384
Gel	4.647	0.18845	0.01693	0.20120	0.05616	4.1842
Formula Fe <sub>2</sub> O <sub>3</sub> , 0.283 NaCl, 1.163 NaOH, 140.8 H <sub>2</sub> O NaOH used NaOH necessary NaOH in excess 30.719 grams 8.693 grams 22.026 grams						

DETERMINATION No. 4

Composition	Total weight	Fe	Cl	OH	Na	H <sub>2</sub> O
Original solution	102.169	0.19623	0.38895	0.64097	0.88440	100.0589
Mother liquor	97.380	0	0.37274	0.43490	0.83122	95.7412
Gel	4.789	0.19623	0.01621	0.20607	0.05318	4.3177
Formula Fe <sub>2</sub> O <sub>3</sub> , 0.260 NaCl, 1.053 NaOH, 139.5 H <sub>2</sub> O						
NaOH used NaOH necessary NaOH in excess						
32.390 9.050 grams 23.340 grams						

DETERMINATION No. 5 (a)

Composition	Total weight	Fe	Cl	OH	Na	H <sub>2</sub> O
Original solution	97.445	0.14075	0.29711	0.93793	1.29414	94.7751
Mother liquor	93.084	0	0.28606	0.76973	1.22940	90.7986
Gel	4.361	0.14075	0.01105	0.16820	0.06474	3.9765
Formula Fe <sub>2</sub> O <sub>3</sub> , 0.248 NaCl, 1.983 NaOH, 178.3 H <sub>2</sub> O						
NaOH used NaOH necessary NaOH in excess						
47.395 grams 6.493 grams 40.902 grams						

gram NaOH per gram of solution) added over and above the amount necessary for complete precipitation of the iron. The figure in parenthesis represents the number of times more solution added than theoretically necessary. "NaCl" and "NaOH" express the adsorbed constituents in terms of unit amount of  $\text{Fe}_2\text{O}_3$ .

No.	Excess of NaOH		$\text{Fe}_2\text{O}_3$	N aCl	NaOH	$\text{H}_2\text{O}$
	Grams	Times				
1	1.507	(0.14)	1.0	0.432	0.247	132.8
2	19.950	(2.17)	1.0	0.273	0.986	136.0
3	22.026	(2.52)	1.0	0.283	1.163	140.8
4	23.340	(2.57)	1.0	0.260	1.053	139.5
5	40.902	(6.3)	1.0	0.248	1.983	178.3

The above table shows the effect of the concentration of sodium hydroxide on the amount of chlorine adsorbed. In No. 1, in which there is only a very slight excess of sodium hydroxide, the amount of chlorine adsorbed is greater than in any succeeding case. In No. 5, in which the excess of alkali added is quite large, there is only about one-half as much chlorine carried down as in No. 1. Nos. 2, 3 and 4 are intermediate *between* these two extremes. It is interesting to note that the values for adsorbed chloride in Nos. 2, 3, and 4 are but slightly greater than in No. 5, even though three times as great an excess of alkali was used in the latter case as in the former ones. This *shows* that above a certain concentration, the excess of sodium hydroxide present has but slight effect in cutting down the extent of adsorption.

As regards the carrying down of alkali by gelatinous ferric hydroxide, we should expect that the amount likely to be carried down<sup>1</sup> would be greater, the greater the excess present.

<sup>1</sup> The following is interesting as an experiment illustrating qualitatively that sodium hydroxide is adsorbed by gelatinous ferric hydroxide: 68 grams of a ferric chloride solution (0.00317 gram Fe per gram of solution) required for complete precipitation of the iron 9.8 grams of a sodium hydroxide solution (0.0466 gram NaOH per gram of solution). When 0.5 gram more of this solution than necessary for complete precipitation was added and the supernatant liquid tested for alkali with phenolphthalein, the solution remained colorless.

This was found to be the case as shown in the above table.

Since a gel which contains a large amount of water tends to shrink and lose some of this water on standing, the greater the length of time of standing the less will be the water content. The chloride and alkali contents will likewise diminish on standing by reason of their diffusion into the supernatant liquid.

Since all of the above conditions influence the composition of gelatinous ferric hydroxide prepared in the manner described, it is evident that the same values will not be obtained twice in succession, unless precautions are taken to have the concentrations of the reacting substances exactly the same and to allow the same time to elapse between precipitation and removal of the supernatant liquid for analysis.

The question may naturally have arisen that if it is possible to pour off practically all of the supernatant liquor, why not analyze for the constituents of the gel directly without resorting to an indirect method at all? The answer to this question is at hand when we consider the difficulties involved in removing entirely 0.01 gram of chlorine from a solution containing twenty times as much iron, or how impossible it would be to analyze with anything like quantitative accuracy for from 0.02 to 0.06 of a gram of sodium in the presence of such a large excess of iron, unless a great amount of time were spent in working up a method that would be applicable quantitatively in the particular case at hand.

Then, too, this is a specific case in which the supernatant liquor could be poured off without stirring up the solid. The method is just as applicable by the volume-density determinations in cases in which the mother liquor can not be poured off. Furthermore, cases may arise in which the difficulties of direct quantitative analysis are even greater than in the case under consideration. The two methods of indirect analysis given, describe the mode of attack in determining the composition of a gel. The methods are perfectly general in their nature and may be employed in any

case in which the conditions are such that an indirect method is applicable.

It is interesting to note the magnitude of the error introduced in the gel analyzed, if the composition is calculated on the assumption that no chlorine is adsorbed and the constituents expressed in terms of unit amount of chlorine, as before described in Part I.

The following table gives the determination, No. 5 above, calculated on this basis. Whereas the correct composition is  $\text{Fe}_2\text{O}_3$ , 0.248 NaCl, 1.583 NaOH, 178.3  $\text{H}_2\text{O}$ , if we calculate on the assumption that no chlorine is adsorbed, a result is obtained showing the amount of alkali carried down to be less than one-third what it should be, and the water content to be actually negative. This is exactly what was found and described in the first part of this paper.

#### Summary and Conclusions

1. The composition of a gel may be determined by *indirect analysis*. The method employed is a general one but is subject to certain well-defined limitations. These limitations are as follows:

Case I. In which at least one component of the system from which the gel separates does not enter into it.

1. It must be possible to analyze accurately for all components.

2. There must be an appreciable difference in the concentration of the solution before and after the separation of the gel.

3. The gel must settle sufficiently to allow the mother liquor to be removed and analyzed.

Since by definition, at least one component of the system from which the gel separates does not enter into it, the relative amounts of the various constituents before and after precipitation are expressed in terms of unit amount of this unadsorbed constituent. The difference between these values gives the *relative* amount of each present in the gel. Gelatinous ferric hydroxide prepared by precipitation from ferric chloride

## DETERMINATION No. 5 (b)

Constituents	Fe	Cl	OH	Na	H <sub>2</sub> O
Composition of 1000 grams of solution before mixing	1.4444	3.0490	9.6392	13.2800	972.6015
Composition of 1000 grams of solution after mixing	0.0000	3.0556	8.2211	13.1300	975.5933
Composition before mixing calculated	473.73	1000.00	3161.45	4355.70	318985
Composition after mixing calculated	0.00	1000.00	2690.80	4296.70	319315
Difference = gel	473.73	0.00	470.65	59.00	—330
Expressed as Equivalents					
Composition of 1000 grams of solution before mixing	0.02584	0.08600	566.75	0.57615	43.6980
Composition of 1000 grams of solution after mixing	0.00000	0.08618	0.26908	0.42967	43.8330
Composition before mixing calculated	8.474	28.208	185.88	188.97	14332
Composition after mixing calculated	0.000	28.208	158.21	186.45	14347
Difference = gel	8.474	0.000	27.67	2.52	—15
Percent error 0.9 percent					
NaOH used	NaOH required	NaOH in excess			
47.395 grams	6.493 grams	40.902 grams			

solution by caustic soda cannot be analyzed under this method, since all of the constituents enter into the gel. It can be determined, however, under

Case II in which all the components of the system from which the gel separates enter into it.

In this case conditions one and two are the same, and in addition the separated gel must be of such a nature that it will mat together in a homogeneous mass, so that the volume of all the mother liquor can be read. With these conditions obtaining the exact total composition of the solution in terms of all the various constituents before and after precipitation may be determined. The difference between these values, gives the *absolute* amount of each present in the gel.

2. The composition of the ferric hydroxide gel, determined by the method given in Case II above, varies widely under different conditions, chlorine, alkali and water being carried down in varying amounts.

Generally speaking, the amount of material adsorbed is proportional to the amount present. The adsorption of chloride is however appreciably lessened by the presence of an excess of caustic soda, although it is not entirely prevented.

In conclusion, I express my sincerest thanks to Professor Bancroft, at whose suggestion and under whose kindly supervision this work was done.

*Cornell University*

## ANHYDROUS SODIUM SULPHATE AND WATER

BY D. T. WILBER

At temperatures below  $32.6^{\circ}$  the moistening of anhydrous sodium sulphate with water causes an evolution of heat owing to the formation of the decahydrate. It was found by de Coppet<sup>1</sup> that heat is evolved at higher temperatures. Sodium sulphate was dehydrated at  $100^{\circ}$  and placed in a thin-walled glass bulb. The bulb was placed in a flask containing a thermometer and a little water. The flask, with its contents, was placed in a constant temperature air-bath and allowed to come to equilibrium. The bulb was then broken and the rise of temperature noted. The rise was  $2.1^{\circ}$  from an initial temperature of  $39.8^{\circ}$ ,  $5.9^{\circ}$  from  $51.2^{\circ}$ ,  $6.4^{\circ}$  from  $71.6^{\circ}$  and  $10.4^{\circ}$  from  $90.1^{\circ}$ , the actual rise being greater the initial temperature, for the range of temperatures studied. De Coppet explained this rise in temperature at first by assuming two isomeric forms of sodium sulphate; but he abandoned this later<sup>2</sup> without offering any new explanation.

Julius Thomsen<sup>3</sup> considered that a monohydrate is formed; but that is known not to be the case. Thomsen's presentation of the matter is misleading. He says that the heat due to the formation of the monohydrate may raise the temperature above the boiling point of water. While this is true, it would have been better to have stated also that the temperature does not rise above  $103.2^{\circ}$ , the boiling point of the saturated solution.

The rise of temperature is of course due to the fact that anhydrous sodium sulphate is less soluble at high temperatures than at low temperatures and consequently dissolves with evolution of heat. This explanation has already been given;<sup>4</sup> but the increasing rise in temperature with increasing initial

<sup>1</sup> Comptes rendus, 79, 167 (1874).

<sup>2</sup> Ber. chem. Ges. Berlin, 12, 248 (1879).

<sup>3</sup> Thermochemische Untersuchungen, 3, 122 (1883).

<sup>4</sup> Dammer's Handbuch der anorganischen Chemie, 2, II, 155 (1894).



temperature is there accounted for by the assumption that the heat of solution increases in amount with rising temperature. A glance at the solubility curve shows that this explicit assumption is not true. This difficulty disappears if one remembers that the rise in temperature in these experiments depends on the rate at which heat is evolved as well as on the amount of heat evolved. At the higher temperatures of 90°, equilibrium is approached so much more rapidly that the amount of heat evolved in a given brief interval of time is greater than at 40° though the total heat evolved up to equilibrium is greater in the latter case.

*Cornell University*

## NEW BOOKS

**Treatise on General and Industrial Inorganic Chemistry.** By *Ettore Molinari*. Translated by *Ernest Feilmann*. Third edition. 6 × 10 cm; pp. xvi + 709. Philadelphia: P. Blakiston's Son and Co., 1912. Price: \$6.00.—“A treatise on General and Industrial Inorganic Chemistry” is the name of a large work by Dr. Ettore Molinari, in which he attempts to classify and present to students in chemistry, the practical application of the multitude of facts of the science, its laws and theories, to our industrial world and business enterprises. It is not a book intended for the beginner and one untrained in chemistry, but for the advanced student who wishes to apply his knowledge to industrial problems. He has also taken great pains to incorporate in this book a class of information not usually found in a textbook, that is the price and size of market for the different chemicals and products with which he deals. He states in his preface to the first edition his aim in doing this.

“In the special portion I have always endeavored to emphasize very briefly those industrial processes which deal with the preparation of the more common compounds. By means of the ordinary textbook it is difficult for the student to form a conception of the greater or lesser importance of any one compound compared to others. Many, for example, do not know whether arsenious anhydride has other application than that of destroying rats. . . . ; whether phosphorus has other uses than for the heads of matches; or whether hydrogen serves other purposes than the inflating of balloons. I have endeavored to indicate as completely as possible the varied application of each substance, and have summarized their present and past importance by means of statistics.

“In the case of each substance I have indicated its commercial price without any desire to offer a commercial price list of chemical products, but merely for the sake of orientation, as quite often it is unknown whether a cubic meter of oxygen costs 2d or 4s, whether ammonia costs more or less than nitric acid, copper more or less than aluminum or nickel, etc. Generally nothing is available with regard to the prices of chemical products than the fantastic price lists of the pharmacists.

“I have purposely omitted descriptions of the ordinary laboratory apparatus and have substituted, for their cumbersome material, simple and illuminating sketches of industrial apparatus and processes which I have collected from the best works on chemical technology.

“I am far from believing that this book may be considered as a treatise on chemical technology, but it is my belief that industrial chemistry must start from the foundations of general chemical culture embodied in this treatise, in order to enter into all the technical and economical conditions of manufacture of the more important compounds, and in order to place our young chemist in a position to assume direction of, and collaboration with, our chemical industry with more success and utility.”

The form and arrangement that the author has used in taking up the field is efficient and pleasing. A somewhat abbreviated outline of the contents of this book will show the arrangement and scope of the work: “Part I General,” is composed of chapters on: matter, space, substance and mass; physical and

chemical phenomena; history of chemistry; fundamental laws of modern chemistry; laws of matter in the gaseous state; chemical equations; matter in the liquid state; study of dilute solutions; and lastly, matter in the solid state. These chapters of Part I occupy 125 pages and, as inspection will show, cover the general field of physical chemistry unusually well for a text of this kind. The same symbols are used in the formulæ and laws as we are all accustomed to in our own texts, but the English system of money is used throughout the book.

Part II deals with the non-metals and is covered by subdivisions into the following heads: classification of the elements; non-metals; hydrogen compounds of the halogens; oxygen compounds of the halogens; oxygen group; hydrogen compounds of the group; oxygen, sulphur, selenium, tellurium; oxygen compounds of sulphur, selenium, tellurium; nitrogen group; hydrogen compounds of the trivalent non-metals; oxygen derivatives of the trivalent non-metals; vanadium, niobium, tantalum; carbon group.

The text in Part II is quite full and complete and deals with laboratory methods as well as with purely industrial matters. In the discussions as to occurrence of some of the mineral deposits and their importance the author has sometimes treated the foreign deposits so thoroughly and those of the United States so briefly as to give one an underestimate of the value of our mineral resources. Such is the case with our sulphur as compared to the Sicilian product. But great interest has been added to the work by footnotes dealing with many of the economic problems of the industry under consideration. As has been mentioned, the book is fully illustrated and the drawings are supposed to furnish the reader with the important details, in place of lengthy descriptions: in this regard they are very good and include such late pieces of apparatus as the Birke-land-Eyde furnaces, the Badische Anilin und Soda-Fabrik furnaces and the Helbig furnace for the production of nitrates from the nitrogen of the air.

Part III deals with the general subject of the metals and is covered by the following chapters: metals; electrochemistry, Group I and Group II; magnesium subgroup; copper, silver and gold; Group III trivalent metals; Group IV tetravalent metals; and Groups V to VIII, inclusive, take up the common metals and their extraction from the ores, and this part closes with the metals of the platinum group. In connection with this last Part III, there is an interesting chapter on the metallography and micrography of iron and steel with twelve lithograph plates showing different specimens of the iron and steel diagram.

The book as a whole is closed by a chapter on the periodic system of the elements and an appendix to the chapter on "water" and also many additional statistics.

The translator has been very clear and accurate in his work and whenever doubt as to meaning comes up a "Translator's note" is inserted by way of explanation.

Charles O. Brown

*Grundriss der Kolloidchemie.* By Wolfgang Ostwald. 17 X 24 cm; pp. 329. Third Ed., Part I. Leipzig: Theodor Steinkopff, 1912. Price: 9 marks. —The second edition of the first volume was exhausted before the second volume was completed. The third edition is a reprint of the second edition. The book is divided into a general and a special part. Under the general heading of the theory of the colloidal states, the author points out that colloids are disperse

systems, and then considers the degree of dispersity. He makes the usual distinction between suspensoids and emulsoids and then discusses the general energetics of dispersoids, meaning thereby the surface tension relations. The final chapter in this portion of the book emphasizes the fact that the colloidal state is entirely independent of the chemical nature of the phases concerned.

The second part of the volume is classified as special instead of general; but this is rather a courtesy title because the author is really considering the general physical chemical properties of colloids under the specific headings of: volume and mass relations in colloids; viscosity and surface tension of colloids; Brownian movements, diffusion, dialysis, osmosis and filtration of colloids.

Among the interesting things noted by the reviewer while reading the book are: the determination of the sign of the charge on colloidal particles by noting the capillary rise in filter paper, p. 17; the cut facing p. 32, which gives to scale the relative sizes of *Bacillus anthrax*, colloidal gold, and mastic particles; the fact that globulin when really free from salt is precipitated by a 0.3 per cent sodium chloride solution, p. 65; the electrical dispersion of sulphur in turpentine, p. 82; the varying solubility of a silica jelly with varying concentration of the jelly, p. 90; the lowering of the melting-point of salol by grinding to a fine powder, p. 113; the adsorption of styrol by metastyrol, p. 130; the vapor pressures of soap solutions, p. 160; the evidence for supersaturation in colloidal solutions, p. 172; the solubility of zein in aqueous alcohol, p. 214; the effect of grinding on cellulose, p. 217; the behavior of saponin films, p. 222; and the action of dialyzed iron solutions towards filter paper, p. 285.

In spite of its many good points, the reviewer does not find this book as good or as useful as Freundlich's book; but the purchasing public is evidently of a different opinion, for this book apparently sells well while Freundlich's has not gone into a second edition. Whatever one's views as to the relative merits of the two books, there is no question but that the new edition is incomparably better than the old one.

Wilder D. Bancroft

**Kolloidchemie.** By Richard Zsigmondy. 18 × 24 cm; pp. 281. Leipzig: Otto Spamer, 1912. Price: 15 marks.—The author gives a general outline of colloid chemistry as he sees it, and follows this with a more detailed account of the characteristics of special groups of colloids. In the general part the headings are: introduction; systematics, properties of colloids; theory. The author considers, p. 8, that the so-called reversible colloids are less like the irreversible colloids than like the true solutions, differing from these latter chiefly in respect to molecular weight. He also considers that there is a marked difference in the properties of a suspension, p. 17, when the diameter of the particles becomes less than 0.1  $\mu$ . Since coarse suspensions of sand, p. 19, do not precipitate rapidly with a low concentration of electrolytes, the author considers that coarse suspensions have practically none of the properties of the colloidal suspensions. He also considers colloidal suspensions of quartz, p. 20, as quite different from colloidal metals because the coagulation is irreversible with the latter and reversible with the former. It is doubtful whether many people will endorse this view.

In the special part the headings are: colloidal metals; colloidal non-metals; colloidal oxides; colloidal sulphides; colloidal salts; soaps and dyes; albumin-

oids. Very interesting is the discussion of brown gold, pp. 100, 107, in its bearing on the shape of the gold particles. Most people do not realize that a protecting colloid may have the same sign, p. 119, as the colloidal substance which it protects, nor that colloidal silver, p. 130, is coagulated very rapidly by a number of alcohols. It is also distinctly interesting, p. 124, that prussic acid has less effect on the platinum catalysis of hydrogen peroxide when added to the solution after the hydrogen peroxide instead of before. The adsorption of gold by gelatine, p. 119, has a distinct bearing on the action of gelatine as affecting the appearance of an electrolytically deposited metal. Since colloidal sulphur remains water-soluble, after the sodium sulphate is replaced by sodium chloride, p. 142, it is clear that the sulphate cannot be the important factor in determining the peptonization. Since potassium salts coagulate colloidal sulphur, it looks as though the specific action of the sodium radical was the thing to be kept in mind.

Although the author's discussion of stannic and metastannic acid is good, pp. 169, 175, the reviewer would have been glad of more. It is really very important to determine just what the difference is between these two alleged forms of stannic acid, because this probably has a very distinct bearing on the cellulose problem among others. The quantitative adsorption of phosphoric acid is also interesting, p. 175.

The section on colloidal iron is good, p. 178, and it is a pleasure to note that the author accepts Biltz's work as to the non-formation of ferric arsenate under the conditions described. One cannot rejoice so unrestrictedly over the fact that the author has accepted, p. 207, von Weimarn's view on jellies without modification. One would have liked to know whether the author considered that the solubility of albumin in a concentrated copper sulphate solution, p. 245, really was a phenomenon analogous to the solubility of globulin in sodium chloride solution, p. 246.

The book errs too much on the side of lack of theory. While the author did this intentionally, this does not appeal to the reviewer. We need a theory of colloids much more than we do a recital of facts. The only way to get one is to keep on trying. Except for this defect the author has written an admirable book and one which is immeasurably superior to the author's previous book on colloid chemistry, which was distinctly not a good one.

*Wilder D. Bancroft*

*Lehrbuch der Photochemie. By Alfred Benrath. 22 × 15 cm; pp. 280. Heidelberg: Carl Winter's Universitätsbuchhandlung, 1912.*—The author treats the subject under the headings: early history of photochemistry; history of photochemistry; recent history of photochemistry; compilation of photochemical reactions; outline of kinetics and statics of photochemical reactions. The first three chapters are not interesting at all and the merit of the book is to be found in the last two chapters or nowhere.

The author considers, p. 124, that photochemical processes may be grouped under four heads: photosynthesis; photolysis; photo-isomerization and photopolymerization; photo-oxidation and photo-reduction. After discussing photochemical reactions under these heads he goes over some of them again under the headings: photochemical reactions in the biology of plants; changes of dyes in the light. The author's views of solarization are a trifle vague, p. 147. He

assumes that colloidal silver alone can act as a nucleus and that long exposure to light causes the formation of crystalline silver which does not develop. This is an unconscious assimilation and perversion of the fact that adding silver particles to unexposed silver bromide does not make the latter developable while adding colloidal silver does.

The author has given a very creditable summary of photochemical reactions but the theory is rather lacking. After mentioning a number of changes from one stereoisomeric form to another, he then says, p. 163: "The above-mentioned reactions consist in the change of the more fusible and less stable isomer into the less fusible and more stable form. We are thus dealing with exothermal processes which are not fundamentally different from many similar, purely chemical, reactions. Though we are not able, by chemical methods, to convert the stable form back into the labile one except by round-about reactions, this change can easily be brought about by exposing the substance to the action of ultra-violet light. Usually an equilibrium is reached. Sunlight appears therefore to help on the exothermal and ultra-violet light the endothermal reaction. We have therefore a conversion of radiant energy into chemical energy and an increase of the latter. It has not been determined whether all exothermal inversions can be reversed by ultra-violet light."

In the first place, it is perfectly well known that the change of white phosphorus, the less stable form, into red phosphorus, the more stable form, is accelerated by ultra-violet light. In the second place the whole matter is primarily one of absorption of light. Everybody knows that a change can be brought about only by those rays which are absorbed; but this does not seem to be effective knowledge with most people. *Wilder D. Bancroft*

**Notes on Chemical Research.** By *W. P. Dreyer*. 13 × 19 cm; pp. v + 68. Philadelphia: P. Blakiston's Son and Co., 1913. Price: \$1.00.—At first sight a book on how to do research work seems to be preposterous. The only way to learn how to do research work is to do research work. Since research work consists in surmounting difficulties which never have arisen before, it is hard to see how this can be taught to a student in any other way than by experience. On the other hand, there is a great deal that is common to nearly all bits of research work, and this is what the author has in mind. His book should really be entitled "Notes on the Routine of Chemical Research."

The subdivisions of the subject are: historical review and nature of research; preliminary survey and selection of subject matter; general procedure and selection of methods of investigation; chemical and general scientific investigation; application of chemical research to industry; research in relation to analysis; general conclusions.

This book constitutes a painstaking piece of work. It is accurate in detail but absolutely lacking in brilliancy and inspiration. While the book may be helpful to English students, one cannot help thinking how differently Ostwald would have done the same thing.

The reviewer would have liked to have found something more in regard to the fundamental question of how to get round an experimental or theoretical difficulty. He himself practices the Socratic method of elimination and always tries to say that the trouble is due to this or to that, the two being mutually

exclusive. This has the advantage of bringing out clearly just where one stands at any moment. Most people, however, merely try to guess the answer and consequently do not narrow the field except by the actual number of guesses.

*Wilder D. Bancroft*

**Osmotic Pressure.** By Alexander Findlay. 22 × 15 cm; pp. vii + 84. New York: Longmans, Green and Co., 1913. Price: \$1.00.—The chapters are entitled: semipermeable membranes and osmotic pressure; van't Hoff's theory of dilute solutions; direct determination of the osmotic pressure of concentrated solutions; discussion of the recent determinations of osmotic pressure, and of the van't Hoff theory; the general theory of ideal solutions; discussion of the osmotic pressure of aqueous solutions of cane sugar in the light of ideal solutions; indirect determination of the osmotic pressure; views regarding the cause of osmosis and the action of the semipermeable membrane.

This is an excellent account of what is known in regard to osmotic pressure. The author points out clearly, p. 8, that the osmotic pressure is proportional to the absolute temperature only in case "the solution is so dilute that the heat effect on further dilution is negligible." After discussing the data of Morse and of the Earl of Berkeley the author points out, p. 26, that "from what has just been said it follows that the Boyle-van't Hoff law and the Gay-Lussac-van't Hoff law do not hold with any accuracy over the range of concentration and temperature investigated. Nor, indeed, was it to be expected that they would. Since, in the deduction of the van't Hoff theory, simplifying assumptions were introduced which could be valid only in the case of infinitely dilute solutions, the theory made no claim to be a general theory of solutions applicable to all concentrations, and the experimental investigation of osmotic pressures could serve the purpose only of defining the limits within which the simplifying assumptions could be regarded as still applicable. That the range of validity of the van't Hoff theory is comparatively small, in the case at least of solutions of cane sugar, is shown by the determinations of Morse and his co-workers as well as, more strikingly, by the experiments of Lord Berkeley and E. G. J. Hartley. Although better agreement is obtained when the osmotic pressures are calculated according to the method of Morse, still the need is felt for an expression which shall represent the quantitative properties of a solution over a wider range of concentration."

The reviewer regrets that so excellent a book should be marred by the statement, p. 44, that the osmotic pressure depends on the degree of association of the liquid solvent.

*Wilder D. Bancroft*

**Les Atomes.** By Jean Perrin. 12 × 19 cm; pp. xvi + 291. Paris: Felix Alcan. Price: 3.50 francs.—The headings of the chapters are: atomic theory and chemistry; molecular agitation; Brownian movements of emulsions; laws of the Brownian movements; fluctuations; light and quanta; the atom of electricity; genesis and destruction of atoms. The author points out that the values of  $N/10^{23}$  vary only between 60 and 75 though calculated from such apparently different phenomena as the viscosity of gases, the Brownian movements, the blue of the sky, the light emitted by black bodies, the charge on the particles of a gas, and radioactivity. The author concludes, p. 291, that the atomic theory

has triumphed and that the many people who have opposed it are laying down their arms, one by one. There is no index. *Wilder D. Bancroft*

**Le Celluloid et ses succédanés.** By W. Main. 19 × 12 cm; pp. 160. Paris: Gauthier-Villars. Price: 3 francs.—The headings of the chapters are: cellulose and its nitration; camphor and other substances added to the nitrocellulose to form celluloid; manufacture of celluloid; viscose and viscoïd; cellulose acetates; albuminoid substitutes for celluloid; different celluloids and different substitutes; properties and composition of various plastic materials; manipulation of celluloid and its substitutes; various economic contingencies.

The author starts with the orthodox number of cellulose nitrates, nine in all; but he admits that the cellulose acetates, p. 72, are ill-defined mixtures whose properties vary with the method of preparation. The author gives a number of interesting facts and he includes a paragraph on bakelite; but, somehow, one does not get any clear-cut view of the celluloid industry from the book.

*Wilder D. Bancroft*

**Jahrbuch der Elektrochemie.** Vol. 13 (1906). By Heinrich Danneel and Julius Meyer. 24 × 17 cm.; pp iii + 869. Halle: Wilhelm Knapp, 1913. Price: 32 marks.—The volume for 1906 has at last appeared six years late. In order to give the work the value that it should have, some arrangement should be made whereby the editors might catch up, even if it were necessary to drop out half a dozen years. It would be a pity to drop the series entirely because it might be very valuable. The reviewer confesses, with some shame, that he has found articles referred to in this volume which interested him very much and which had escaped him during this long period.

The editorial duties are hereafter to be undertaken by Dr. Julius Meyer who expresses the hope that the reaction velocity will increase in the future. The collaborators are: H. Danneel, J. Meyer, H. Pick, F. Harms, H. Ley, G. Grube, A. Wacker, J. Hess, M. Spitzer, and Stockmeier. Barring the time factor, the work has been well done. *Wilder D. Bancroft*



## THE DISSOCIATION OF MERCURIC OXIDE

BY GUY B. TAYLOR AND GEORGE A. HULETT

The extreme importance of mercury in scientific work and the ease with which it acquires a dirty appearance, sticking to glass, or forming very small globules which will not coalesce, make a study of the conditions under which this occurs of some interest. It has been assumed that these small globules are surrounded by a film of a foreign metallic oxide, but the same effect is observed when the non-oxidizable metals, silver, gold, or platinum, are the only other metals present.<sup>1</sup> The merest trace of any foreign metal will usually cause the mercury to leave a "tail" when run over an inclined surface.<sup>2</sup> We found that when oxygen is passed over pure mercury at 200° C, the surface remained bright, but the metal showed a decided tendency to adhere to porcelain and leave a "tail." The question now arises whether or not mercury itself is oxidized under ordinary atmospheric conditions and whether traces of other metals act as catalyzers for this reaction. A knowledge of equilibrium conditions in the system mercury, oxygen, and mercuric oxide is essential. An examination of the literature reveals little information regarding this subject, so the first object of this investigation has been the determination of the dissociation pressure of mercuric oxide at low temperatures.

*Historical.*—The relation between mercury and oxygen has played an important part in the development of chemistry. That a red substance was formed by heating mercury for a long time in the air was known to the Latin Geber of the thirteenth century. It was the decomposition of this red substance that led to the discovery of oxygen by Priestley, 1774. One of Lavoisier's earliest experiments in demonstrating the law of quantitative combination consisted in heating a closed system of mercury and air, noting the shrinkage of the air volume, and then recovering the same volume of gas by decomposing the red crystals formed.<sup>3</sup>



The first attempt at measuring the dissociation pressure of mercuric oxide was made by Myers,<sup>4</sup> who concluded that above 400° C the partial pressure of oxygen had no upper limit, but Myers' apparatus was defective as was pointed out at the time by Debray.<sup>5</sup>

Echols<sup>6</sup> undertook to determine the temperature at which oxygen and mercury combine by passing air or oxygen over the liquid metal. The oxide began to form at 450° C. The oxide when heated alone began to decompose at 630° C. His experiments are interesting merely as indicating points at which the rate of reaction becomes considerable. According to Pélabon<sup>7</sup> combination is complete at 180° C. Carnelley and Walker,<sup>8</sup> working with what they believed to be the hydroxide, state that dehydration is complete at 175° and that decomposition is rapid at 415° to 440°.

Pélabon's<sup>9</sup> work in determining equilibrium pressures in the system mercury and oxygen above 440° is the most important investigation of this subject. His method consisted in heating together mercury and oxygen in sealed tubes until equilibrium was established, then cooling suddenly and measuring the oxygen, from which its partial pressure at the temperature of the experiment was calculated. Two series of experiments were made, one with the mercury and oxygen in equivalent proportions and the other with mercury in excess. He found that in the second case (*i. e.*, with the partial pressure of the mercury equal to its saturation pressure) the partial pressure of the oxygen could be expressed by the formula:

$$\log p = -\frac{27569}{T} - 57.58 \log T + 203.94711$$

where  $p$  is pressure in mm of mercury at the absolute temperature  $T$ .

From this formula, M. J. Bertrand's equation for the pressure of saturated mercury vapor and considerations of the law of mass action, Pélabon was able to arrive at an expression for the relation between the absolute temperature

and partial pressure of oxygen when the two elements in equivalents are in equilibrium with the solid oxide,

$$\log p = -\frac{10529.8}{T} - 16.61 \log T + 64.58240.$$

His results are given as follows:

°C	<i>p</i> (observed) mm	<i>p</i> (calculated) mm
500	985	972
520	1392	1403
580	3610	3589
610	5162	5308

The temperatures were measured with a Le Chatelier thermo-element. No great accuracy was attempted.

*Discussion.*—The immediate object of our investigation has been to extend the dissociation pressure curve of mercuric oxide below 500° and downward as far as possible. Extrapolated values calculated from Pélabon's formula seem to indicate that the partial pressure of the oxygen falls off rapidly, thus at 450° C it is 337 mm, at 400° C 91.8, at 310° C 3.8 mm. Sufficiently accurate measures of volumes of oxygen as well as the difficulty of maintaining a constant temperature for a sufficient length of time at once exclude the sealed tube method for our purposes. For instance, Pélabon<sup>10</sup> found that at 440° C two days were required for equilibrium, while at 610° only one hour was necessary.

Of the two general methods available for measuring vapor or dissociation pressures, the static as ordinarily employed for oxides,<sup>11</sup> besides being open to all the objections of any static method,<sup>12</sup> is out of the question here since one of the dissociation products is easily condensible on the cold parts of the apparatus.<sup>13</sup> In the dynamic method, the principal difficulty encountered has been the slowness of the rate of reaction. For instance, in the apparatus to be described, a slow current of nitrogen was passed over the purest oxide (25 grams) heated to 468°. In 12 hours, 0.11 gram HgO

had been decomposed corresponding to a partial pressure of oxygen in the volume of nitrogen used of only 0.8 mm, while the true equilibrium partial pressure at this temperature proved to be five hundred times as great.

The vapor-pressure methods of Smith and Menzies<sup>14</sup> seem available for this study, provided the reaction can be made to occur with sufficient rapidity, *i. e.*, by catalysis. This we have been able to accomplish by certain metallic oxides.

The catalyses of solids, or reactions occurring in heterogeneous systems, do not seem to have been much investigated, except in the case of gases by contact substances, such as the formation of water from hydrogen and oxygen in the presence of silver,<sup>15</sup> or platinum,<sup>16</sup> on the well-known accelerating action of platinum or ferric oxide on the reaction  $2\text{SO}_2 + \text{O}_2 = 2\text{SO}_3$ . Few instances of catalysis of solids by solids are known. Many metallic oxides facilitate the escape of oxygen from potassium chlorate, but the reactions involved are complex.<sup>17</sup> A case more in point is the accelerating action of metallic silver on the decomposition of silver oxide, studied by Lewis.<sup>18</sup>

We have found that the decomposition of mercuric oxide is accelerated by finely divided platinum, ferric oxide, manganese dioxide, and cadmium oxide. Oxides like alumina and stannic oxide have no effect. There is no reason to suppose that there is any interaction in the case of the oxides. Each is at its highest state of oxidation and their dissociation pressures are altogether negligible at temperatures we have employed. As will be shown later in the dynamic method, mercury and oxygen are evolved in equivalents from mixtures of mercuric and ferric oxides.

*Preparation of Pure Mercuric Oxide.*—We have given considerable time and attention to a method for the preparation of pure oxide. That made from ignition of the nitrate almost certainly occludes oxides of nitrogen. The problem is to get mercury and oxygen to unite directly and rapidly. In experiments with this end in view, mixtures of mercury vapor and oxygen were passed over a glowing platinum wire

with no results. We also tried the effect of strong light by putting a Nernst glower directly in the neck of a flask containing mercury to which was fed oxygen under pressure. The rate of formation was not noticeably increased. When a large excess of mercury is heated with oxygen under pressure, a white scum first appears on the surface of the metal and then long needle crystals of the oxide.

As a final resort pure oxide was made by heating a large excess of mercury with oxygen in sealed tubes for several hours at  $460^{\circ}$ . The oxygen was prepared by electrolysis of sodium hydroxide solution in an especially constructed generator, and was passed over a glowing platinum wire, to free it from traces of hydrogen, and dried over calcium chloride. The air was carefully pumped out of each tube before filling with oxygen. All connections were glass. The mercury was distilled three times by the method of Hulett.<sup>19</sup> The excess of mercury was removed from the oxide by distillation in a current of oxygen. The process is a slow one and the yield not good. Much of the oxide adheres tightly to the glass and must be scraped off. The crystals obtained were large and transmitted yellow light. The material so prepared was our *normal oxide*.

#### Experimental

*Temperature* was measured with a platinum-platinum 10 percent rhodium thermoelement, and the electromotive force with a Wolff potentiometer against a standard saturated cadmium cell (1.01840 volts), maintained constantly at  $25^{\circ}$  in a thermostat.<sup>20</sup> This thermoelement was standardized at three different times during the course of this investigation and found not to have sensibly changed. Three fixed points were observed, the boiling points of water  $100^{\circ}$ , naphthalene  $218^{\circ}$ , and sulphur  $444.5^{\circ}$ . It was found that the readings in microvolts agreed exactly with the standard of Day and Sosman<sup>21</sup> at the water and naphthalene points, and read 20 microvolts lower at the boiling point of sulphur. A straight line deviation from Day and Sosman's curve<sup>22</sup> was plotted

and microvolts corresponding to every  $10^\circ$  from  $300^\circ$  to  $480^\circ$  were calculated. From the table so constructed the temperatures were read by interpolation and are therefore on the nitrogen gas scale.

*Submerged Bulb Method.*—A modification of this method as devised by Smith and Menzies<sup>23</sup> was employed. The bulb shown in Fig. 1 and made of thin lead-glass\* tubing, was drawn out at one end into a capillary 0.5 to 1.0 mm in diameter. This capillary was bent around the bulb for the sake of compactness and not as shown in the figure, in one plane. At A was placed a small plug of glass wool and the bulb was filled as completely as possible from the lower end and sealed off at B. These bulbs were about 5 cm long and 1 cm diameter, and when filled contained about 5 grams of the oxide and an equal volume of catalyzer. The bulbs were designed to contain as large a quantity of oxide as was compatible with a small volume, so that a rapid stream of bubbles might be evolved.

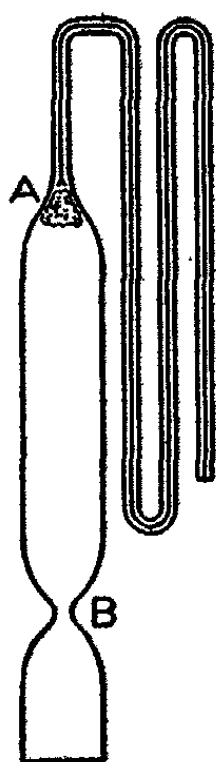

Fig. 1

The essential features of the rest of the apparatus are shown in Fig. 2, a tall one-liter beaker containing melted sodium and potassium nitrate mixture and standing on a sand bath heated from below by a gas burner. An inverted beaker with its bottom cut out and resting on an inverted asbestos air bath supported on the legs of the tripod, served as a jacket. Efficient stirring of the 800 cc or more liquid was accomplished by means of a simple four-bladed propeller wheel carried on the end of a rapidly revolving stiff brass rod. The bulb (not shown in figure) was submerged completely under fused nitrates in the bottom of the long tube. This tube made of Jena glass was closed at the top by a rubber stopper, wired in, through which passed the quartz tube

\* Lead glass does not crack when dropped suddenly into fused nitrates at  $500^\circ$  C.

carrying the thermoelement wires. The side tube provided connection to the pressure tank, suction pump, and manometer. The pressures were read on a simple open arm manometer in conjunction with a barometer. Readings were made to the nearest millimeter and corrections were made for submerged depth. Corrections for capillarity were not applied as they are well within the error of the measurement.

First the bulb was thoroughly boiled out to expel all air and foreign gases by raising the temperature considerably above the boiling point of the solid  $\text{HgO}$ . The bubbling was none too fast so an hour was usually allowed. Then by carefully increasing the pressure a point was reached where bubbling almost ceased. The pressure was now fixed and the temperature very slowly lowered until the liquid began to rise in the capillary, when the temperature was taken to correspond to this fixed pressure.

The pressure was then diminished and fixed, and the temperature allowed to fall until another point was located. The bubbling slowed up near the end points so much that we were obliged to exercise great caution lest the point be reached too soon, indicating temperatures higher than the

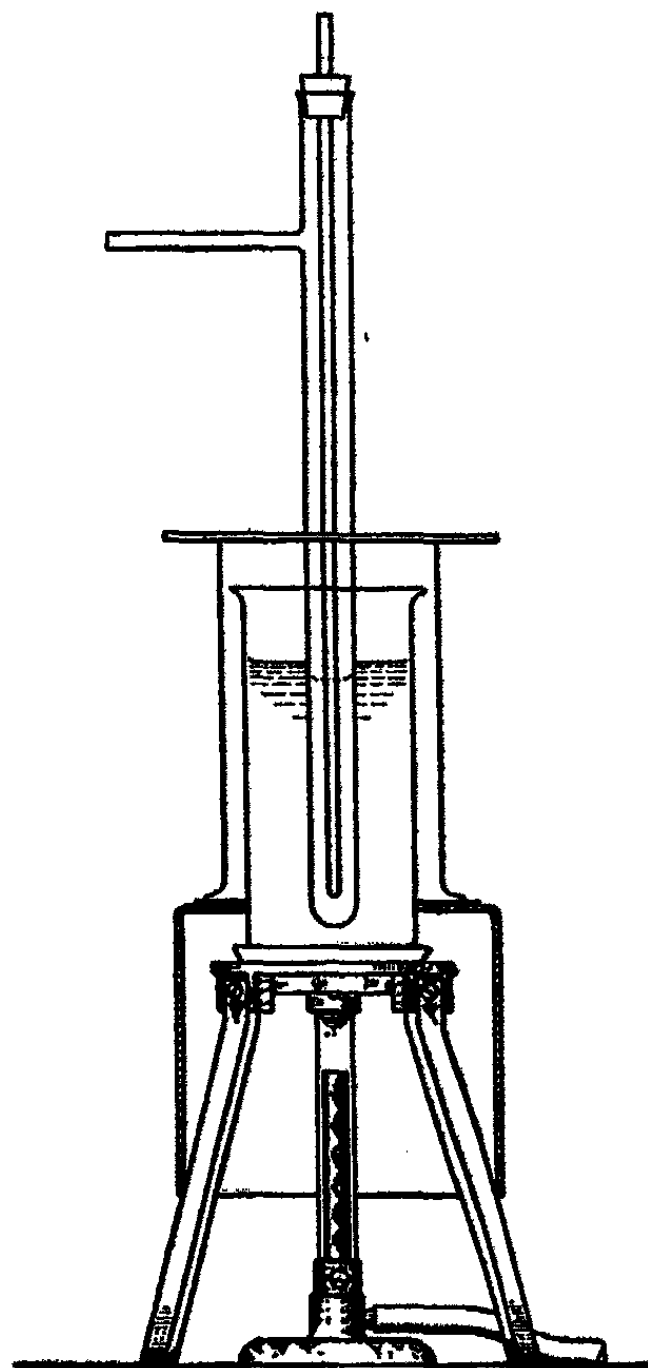

Fig. 2

TABLE I—SUBMERGED BULB METHOD

	°C	Total pressure mm	Partial pressure (observed) mm	Oxygen (calc.) mm
Normal red oxide with $\text{Fe}_2\text{O}_3$	475.7	1430	476.7	482
	470.4	1290	430.0	430
	461.3	1058	352.7	351
	455.0	921	307.0	303
	452.5	856	285.3	285
	437.0	586	(195.3)	200
	411.7	308	(102.7)	107
	380.9	109	(36.3)	47
356.4	39	(13.0)	28	
Kahlbaum red oxide with $\text{Fe}_2\text{O}_3$	474.1	1394	464.7	465
	463.8	1096	365.3	369
	458.1	976	325.3	325
	450.9	830	276.7	276
	444.0	701	233.7	235
	425.4	449	149.7	148
Merck's red oxide with $\text{Fe}_2\text{O}_3$	476.2	1467	489.0	487
	471.3	1303	434.3	436
	465.8	1157	386.3	387
	458.2	982	327.3	326
	417.5	345	(115.0)	122
	404.2	236	(78.7)	87
	396.8	187	(62.3)	72
	363.8	67	(22.3)	32
Merck's red oxide with $\text{MnO}_2$	476.2	1451	483.7	487
	466.7	1175	391.7	392
	458.3	966	322.0	325
	453.0	863	287.7	287
	431.3	512	170.7	173
	420.8	395	131.7	133
Merck's red oxide with $\text{CdO}$	468.0	1217	405.7	406
	459.3	986	328.7	330
	447.8	773	257.7	257
	434.7	553	184.3	186
	421.5	403	134.3	136
	390.0	176	58.7	60



true ones and correspondingly low pressures. The reaction at the lower temperatures is so slow that the pressures indicated by this method are almost certainly too small.

Five series of observations were made as given above. About 5 grams of mercuric oxide were ground and passed through fine bolting cloth, and then mixed with about an equal volume of catalyst, similarly ground and bolted. The ferric oxide used was Kahlbaum's "Brown Label" marked "special," which was ignited before use. The cadmium and manganese oxides were also Kahlbaum's preparations, ordinary grade. Following the usage of Pélabon the results have been calculated to partial pressure of oxygen by dividing the observed pressures by three. Under the column headed "calculated" are given the values taken from our final curve.

*Static Method.*<sup>25</sup>—Here we used the isoteniscope modified by the insertion of a trap to catch the condensed mercury as shown in Fig. 3. The method permits fixing the temperature and adjusting the pressure, an advantage over the submerged bulb method. With fused nitrates as the confining liquid there was no interaction with the mercury vapor.

The apparatus was charged with 5 grams oxide and the catalyst, immersed in the nitrate bath, and thoroughly boiled out. Then with temperature fixed, the pressure was carefully adjusted until the level of the liquid in the two arms remained stationary for some time, care of course being taken not to allow air to re-enter the bulb. The pressure was then reduced, the apparatus allowed to boil out for 15 to 20 minutes and the observation repeated. The response to a change in either pressure or temperature was very slow. The results are given in Table II.

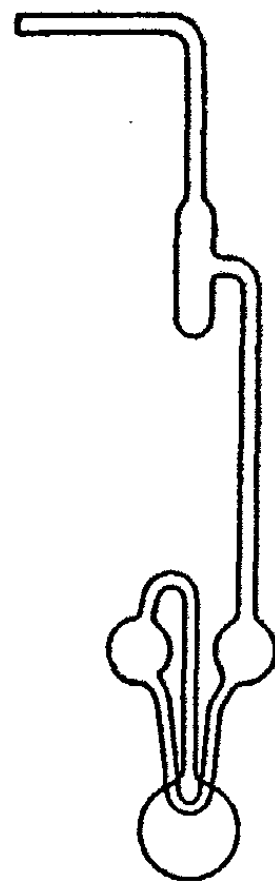

Fig. 3

TABLE II—STATIC METHOD

	° C	Total pressure	Partial pressure (observed) mm	Oxygen (calc.) mm
Red oxide with Fe <sub>2</sub> O <sub>3</sub>	480.0	1580	526.7	527
	469.0	1255	418.3	416
	463.8	1107	369.0	369
	451.7	845	281.7	281
	440.2	642	214.0	214
	436.2	591	197.0	195
	418.2	371	123.7	123
	403.3	252	84.0	84
	388.5	174	58.0	58
Red oxide with CdO	436.6	588	196.0	197
	403.8	260	86.7	86
	369.5	104	34.7	35

An attempt was made to measure the pressure at 480° by this method without a catalyst. In order to ensure the expulsion of all the air the apparatus was kept at 500° under 30 mm pressure for several hours, the temperature then lowered to 480° and the pressure increased as rapidly as the rate of decomposition would permit. At the end of 8 hours a pressure of 1507 mm was reached which was still increasing at the rate of 2 or 3 mm per hour. We then lowered the temperature 4°, and after the first fall of pressure due to contraction of the gases, there began a decrease at about the same rate. At 1486 mm the experiment was discontinued. It is clear that accurate measures could not have been obtained under these conditions, but the results are in harmony with those obtained with the aid of catalysts, and give confidence in them.

*The Dynamic Method.*—Beginning with Regnault<sup>26</sup> this method has been extensively used for vapor pressures particularly at lower temperatures.<sup>27</sup> Briefly it consists in saturating a known volume of an inert gas with the vapor of the substance, and from a knowledge of the quantity of the vapor calculating its partial pressure according to Dalton's law.

The apparatus for this method was practically perfected before we tried either of the other methods, for it was hoped that we would be able to determine directly the dissociation pressure of mercuric oxide at comparatively low temperatures, but the slow rate of decomposition has made this impossible even with a catalyst. We have only been able to confirm our results as obtained above.

The apparatus in its final form is shown in Fig. 4 and consists essentially of a reaction chamber, R, a purifying train for nitrogen gas (D, E, G), devices for collecting the mercury and oxygen, and the aspirator O. The most troublesome and, at the same time, important part of the apparatus is the heating arrangement for the reaction chamber, which must be fairly large in order to ensure saturation at equilibrium conditions. This large chamber must be uniformly heated and maintained at constant temperature for a considerable length of time. Electric heating of a cylindrical chamber seemed to fulfil these conditions best, so we set out to construct an electric resistance furnace that would heat a tube 25 cm long and 2.5 cm diameter uniformly its entire length, and we succeeded finally in getting one that dropped off less than 1° from its center to points 12 cm distant on either side at a temperature of 450° C.

A detailed section through the furnace is shown in Fig. 5. Nichrome wire, 2 mm diameter, was wound on a smooth wooden cylinder, 40 mm diameter, for a length of 56 cm. Exact uniformity in spacing was secured by winding on a lathe, the space between the wires being about the same as the diameter of the wire. Over the windings was wrapped tightly a layer of wet asbestos paper (0.75 mm thick), which was pressed down between the turns by winding No. 20 nickel wire in the spaces. Over this surface was spread a thin paste of magnesium oxide-water glass, filling all depressions and making a smooth cylinder, which when wrapped tightly in a thin sheet of asbestos fitted closely into a brass tube. This tube had the same length as the wire winding and a diameter only 6 mm more than the wooden core, hence the electrical

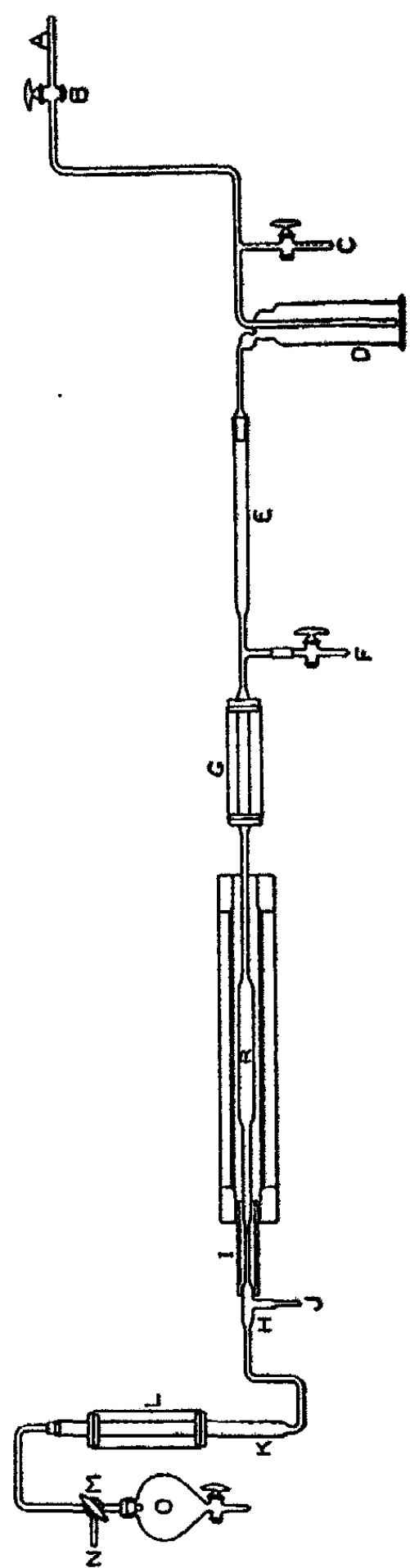

Fig. 4

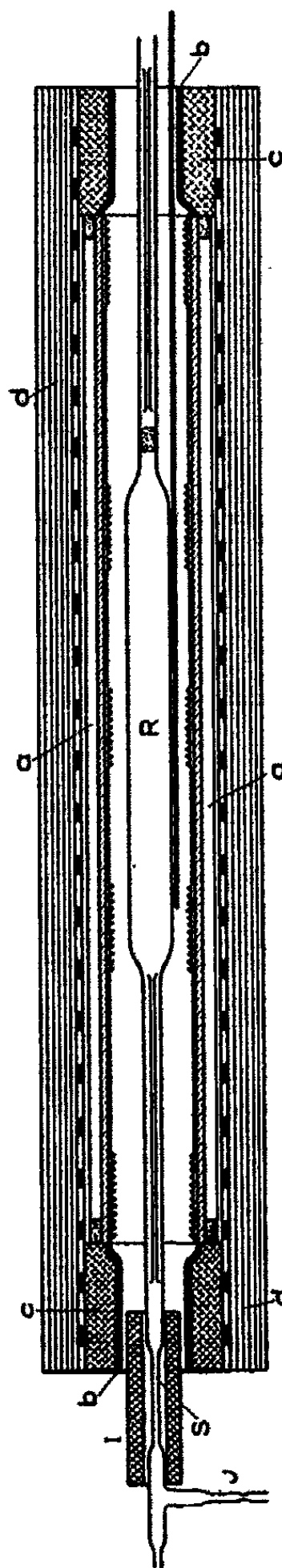

Fig. 5

insulation between brass and wire was 1 mm, making for equalization of temperature by the heat conductivity of the metal. The nichrome wires leading from the heater were wrapped with fine nickel wire to make them better conductors and were fastened securely by notches in the brass tube, being carefully insulated therefrom with mica. The nickel wire had no electrical connection. The wooden arbor was burnt out by boring a small hole longitudinally through it and then while in a perpendicular position, directing a pointed blast flame into the hole together with a current of air. The insulation was next thoroughly dried out by passing a current through a fine nichrome wire stretched through the middle of the tube. We now had a brass cylinder with a heating coil on the inside. The remaining details may be seen by reference to Fig. 5; *aa* is an air space whose outer wall is a glass cylinder. Covering this cylinder is a layer of heavy asbestos paper over which is wound an auxiliary heating coil of nichrome ribbon, serving to warm up the outer insulation and cutting down materially the time necessary to bring the furnace up to temperature; *bb* are porcelain cylinders packed in the ends with pulped asbestos, *cc*; the outer insulation *dd* is a wrapping of thin asbestos board.

The glass parts of the apparatus from E to L, Fig. 4, were made entirely of combustion tubing put together with an oxygen-gas blow pipe to avoid devitrification. The oxide and catalyst were charged in the chamber R. The entrance and exit for gases to this chamber were capillary size as shown in Fig. 5, in order that these gases might have as great velocity as possible. As capillary combustion tubing was not available, we resorted to the expedient of inserting ordinary capillary tubing into the 5 mm hard glass tubes sealed into R. As a further safeguard to diffusion backward as well as distribute the nitrogen entering the chamber, a plug of glass wool was placed at the inner end of the entrance capillary.

The nitrogen supply was contained in a large carboy connected at A (Fig. 4). The gas first passed through the drying tower D, containing calcium chloride and soda lime,

then through E and G. Tube E contained copper, copper oxide, soda lime, and calcium chloride in the order named to remove traces of oxygen and oxidize traces of organic matter. The copper and oxide were heated with a gas burner. Connection between D and E was a ground glass joint made tight with a little marine glue. Tube G contained copper and oxide heated to redness by means of a platinum foil electric heater. Nitrogen was drawn through the apparatus by drawing a measured volume of liquid from the aspirator O.

The mercury was condensed in H and the oxygen caught at L. It was first attempted to catch the oxygen on a roll of copper gauze suspended in the tube and heated to redness by an electric heater, but we found that the oxide had a tendency to scale off of the copper. This trouble was eliminated by hanging a platinum cup beneath the gauze to catch the scales. Then it was found that all of the oxygen was not fixed on the copper so a coil of fine iron wire loosely wound on a porcelain rod was hung above the copper.\*

The remaining details are taken up in the method of operation as follows: Cocks B, F, and M, Fig. 4, were closed and the apparatus exhausted through C. Then C was closed and nitrogen admitted through B. E and G were heated up and a current of nitrogen forced through the apparatus and out at N until all traces of oxygen were thought to have been driven out. Then the tip of tube J was cut off, M closed, and the gases passed out at J while the temperature was being brought up in R. The current for the large furnace was taken from storage cells. By using 50 cells in two sets of 25 each, and these sets connected in parallel, we were able to keep the temperature constant within  $1^{\circ}$  for several hours, after it had once been established. A small sliding resistance and an accurate ammeter were indispensable aids. The thermo-

---

\* A quantity of iron wire sufficient to take care of all the oxygen in some of our runs would have been too large for the tube, hence the combination of copper and iron. That no appreciable amount of oxygen was left in the nitrogen entering R after passage over the two copper gauzes in E and G is shown by the good agreement between oxygen and mercury in our results.

element wires enclosed in a porcelain tube in the position shown in Fig. 5 were so arranged that the temperature at any place along R could be taken. The small electric heater I kept the gases hot until they reached H. It could be pushed completely back into the larger furnace.

In the tube at K was placed an electric glower, made of platinum wire wound on a porcelain tube over which slipped a quartz tube wrapped on the outside with fine iron wire. When the quartz was heated to redness by passing a current through the platinum wire, the iron was made sufficiently hot to take up any oxygen diffusing beyond H while equilibrium was being established in R.<sup>29</sup> It required at least 2 hours to establish the temperature constant and the gases were passed out at J for some time after this in order to ensure equilibrium conditions before the run was started. The rate of flow of nitrogen during this time was the same as that used after the run was begun. The mercury condensed in H was now driven out with a small flame, J sealed off, M opened to O, the current in the glower at K shut off, and the small bore cock F, whose tip just touched a water surface, opened. Aspiration was started by drawing liquid from O and admission of nitrogen at A regulated so that an occasional bubble escaped at F, which ensured that the whole apparatus was always at atmospheric pressure. At the end of the experiment, M was closed, the heater at I pushed back into the large furnace and the small tube S (Fig. 5) sealed off quickly. The mercury was collected from H with the aid of a little weak nitric acid, washed, and dried in a vacuum desiccator. The increase in weight of the copper gauze and iron coil gave the oxygen.

The nitrogen used in these experiments was made by removing oxygen from air with a burning jet of hydrogen according to the method of Hulett.<sup>30</sup> With a long combustion furnace we were able to make 45 liters in less than 2 hours.

*Results.*—The results have been calculated to partial pressure of oxygen from the *oxygen equivalent* of the weight

of the mercury, since a small error in the weight of the oxygen makes a considerable difference in the calculated pressure, and experience has shown that the oxygen weight is less reliable. The scheme of calculation follows:

$$\begin{aligned} \text{Vol. N}_2 &= \text{cc drawn from aspirator} \times \frac{\text{temp. of dissociation}}{\text{temp. in aspirator}} \\ \text{Vol. O}_2 &= \text{wt. Hg} \times 0.08 \times \frac{22412}{32} \times \frac{760}{\text{barometer}} \times \frac{\text{temp. dissociation}}{273} \\ \text{Partial pressure oxygen} &= \frac{\text{Vol. O}_2}{\text{Vol. N}_2 + 3 \times \text{Vol. O}_2} \end{aligned}$$

The temperatures are of course on the absolute scale.

Varying the rate of flow of the nitrogen until slower rates show no increase in the calculated pressure ought to tell us whether equilibrium is being reached or not. The results of a series of experiments at 410° C in order to determine the rate necessary for equilibrium are given in Table III. The reaction chamber in this case was 18 cm long and contained 150 grams oxide and 30 grams ferric oxide as catalyst, which almost completely filled it. In judging whether equilibrium has been reached it must be remembered that the quantity of oxide is diminishing from run to run. The problem was further complicated by the fact that the lower limit of a slow rate was soon reached when diffusion backward from R began. This distinctly happened in run No. 13. The volume of nitrogen in these runs was determined by weighing the water drawn from the aspirator and converting to cubic centimeters. Correction of this volume for aqueous tension was applied. The result of these experiments did not tell us whether equilibrium was reached or not, but slight changes in pressure for great changes in rate showed that we were near it.

Table IV gives results with a larger (25 cm) reaction chamber and a fresh charge.

Table V gives results at 375° C with the larger chamber and an initial charge of 150 grams oxide. The volume of nitrogen in these two series was measured by drawing mercury into accurately calibrated flasks.



TABLE III—DYNAMIC METHOD

Run No.	Time Hours	Volume nitrogen		Vol. N <sub>2</sub> 410°	Rate cc per minute	Wt. O <sub>2</sub>	Mercury wt. = O <sub>2</sub>	Partial pressure oxygen mm
		cc	° C					
7	2 1/4	1000	28	2184	16.2	0.1934	2.539	82.7
8	3 5/4	1000	28.5	2175	9.7	0.2349	2.946	92.0
9	3 1/2	555	28	1213	5.8	0.1420	1.795	97.1
10	2 1/2	351	30	758	5.0	0.0897	1.1263	97.2
11	2 1/2	465	30.5	1004	7.4	0.1137	1.4294	94.6
12	2 1/2	228	28.5	496	3.3	0.0618	0.7670	99.4
13	5	201	27.5	440	1.5	0.0564	0.7245	103.7

TABLE IV

20	3 1/4	350	28	761.0	794	4.1	0.1036	1.303	0.1042	103.4
21	1 1/4	191	27	757.2	435	5.8	0.0586	—	—	104.8
22	1 2/3	250	28	758.4	567	5.7	—	0.8992	0.0719	101.2

TABLE V—375° C

Run No.	Time Hours	Volume nitrogen cc	° C	Bar	Vol. N <sub>2</sub> 410°	Rate cc per minute	Wt. O <sub>2</sub>	Mercury wt. = O <sub>2</sub>	Partial pressure oxygen mm	
										375°
15	3	250	28	760.5	538	2.9	—	0.2322	0.0186	37.1
16	5	500	28	762.8	1076	3.6	0.0431	0.4965	0.0397	39.4
17	3 1/2	500	27	753.3	1080	5.1	0.0415	0.4995	0.0399	39.3
18	2 2/3	500	26	764.8	1083	6.8	0.0366	0.4660	0.0373	37.2
19	4 3/4	500	25.5	764.6	1086	3.8	0.0352	0.4910	0.0393	38.7

Calculated for 410° 101 mm, for 375° 40 mm.

Calculation of results by this method involves two assumptions, first, that the partial pressure of the oxygen in nitrogen purified by passage over copper-copper oxide is negligible and, second, that both oxygen and mercury vapor follow the gas laws. Both assumptions are justified within the errors of experiment. It has been difficult to get as accurate results with this apparatus as the dynamic method might be expected to give, mainly on account of the very slow rate at which the nitrogen must be passed in order to ensure saturation.

#### The Dissociation of Mercuric Oxide

*Discussion of Results.*—We find that on a large scale plot of all our results of partial pressure of oxygen against tem-

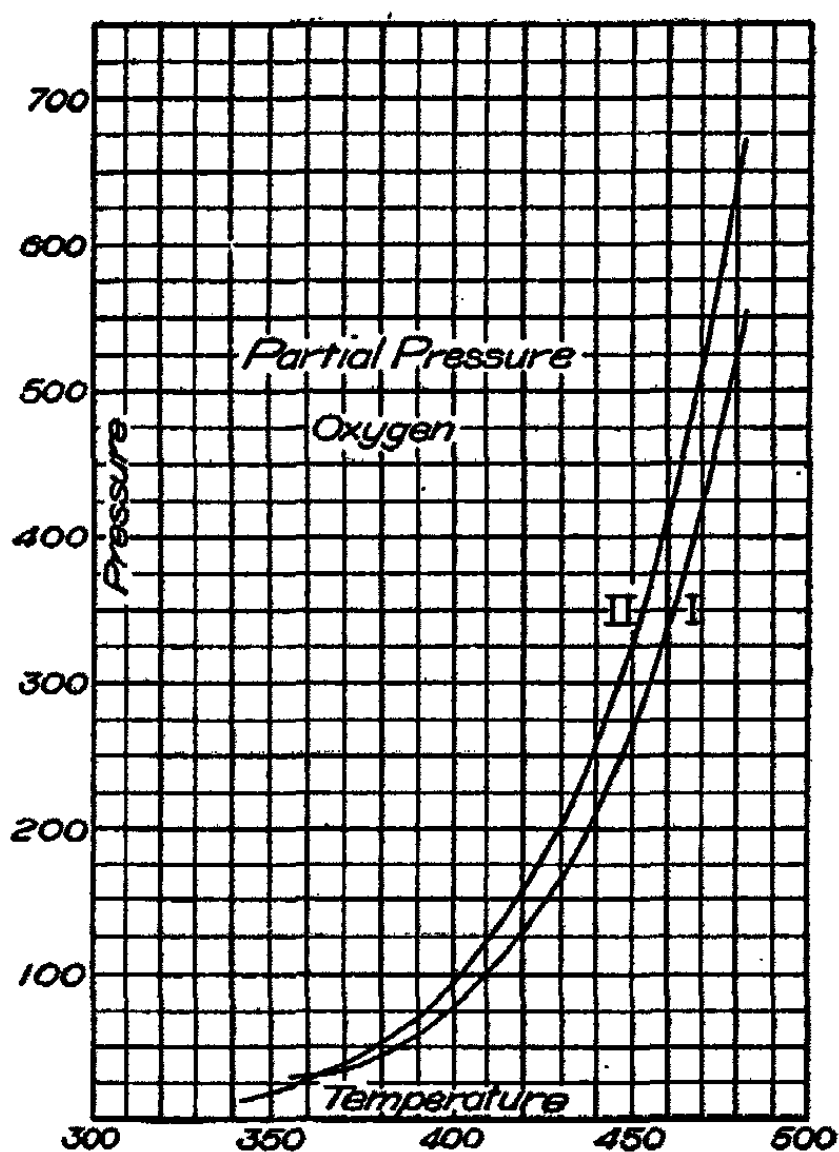

Fig. 6

perature, a smooth curve may be drawn through the points indicated by the static method. Points by the dynamic method and of the higher temperatures by the submerged bulb method lie very closely on this curve, while those of the lower temperatures of the latter lie irregularly below it. The dynamic method confirms the values obtained by the static one as was to be expected, since, as already pointed out, the results by the submerged bulb at lower temperatures were less to be relied upon. The final curve is shown in Fig. 6, and from it we have constructed the following table:

° C	Total pressure mm	Partial pressure oxygen mm
360	90	30
370	108	36
380	141	47
390	180	60
400	231	77
410	303	101
420	387	129
430	498	166
440	642	214
450	810	270
460	1017	339
470	1275	425
480	1581	527

Curve II, Fig. 6, shows extrapolated values from Pélabon's formula.

*Heat of Dissociation.*—Having the dissociation pressures at two different temperatures allows us to calculate the heat of dissociation from the equation of van't Hoff, called by Nernst the *equation of the reaction isochore*,

$$\frac{d \ln K}{dT} = - \frac{U}{RT^2} \quad (1)$$

In the integration of the equation  $U$  is generally regarded as constant but a more accurate value may be calculated by regarding it as a linear function of the temperature,

$$U = U_0 - CT \quad (2)$$

and calculating according to the integrated form given by Lewis<sup>31</sup> in his work on silver oxide,

$$\ln \frac{P_1}{P_2} = -\frac{U_0}{R} \left( \frac{1}{T_1} - \frac{1}{T_2} \right) + \frac{V}{R} \left( \frac{P_1}{T_1} - \frac{P_2}{T_2} \right) + \frac{R-C}{R} \ln \frac{T_1}{T_2} \quad (3)$$

where  $C$  is the diminution in the heat capacity of the system during the decomposition and  $V$  the total change of volume of the *solid* phase. For mercuric oxide the term containing  $V$  is negligible and may be dropped out. The last term in (3) is a correction term and an approximate value for  $C$  will do.  $C$  is the diminution in heat capacity of 2 grams molecules of mercuric oxide after complete dissociation. The specific heat of the solid oxide given in Landolt-Börnstein's tables as due to Regnault is 0.0518, the molecular heat is therefore 11.2 and for two mols 22.4. The molecular heat of mercury vapor at constant volume following the rule of monatomic gases may be taken as 3, and that of oxygen 5. Then for two mols of mercury vapor and one of oxygen the result is 11.0, whence  $C = 11.4$ . Since the dissociation results in three mols,  $3R$  must be substituted wherever  $R$  occurs in the equation.

In applying equation (3) to our results, we have selected the following data and used them in pairs:

(a) 400° C	231 mm
(b) 450°	810
(c) 480°	1581

for  $U_0$ . (a) and (c) give 76430 cal., (b) and (c) 76320, and (a) and (b) 76490 cal. We may take as the value of  $U_0$  the average, 76400 cal.

The heat of formation of mercuric oxide according to equation



has been determined by J. Thomsen<sup>32</sup> to be 22000 cal., by Nernst<sup>33</sup> 20700 cal., and more recently by Varet<sup>34</sup> 21500, all by indirect methods. In order to compare our value of  $U$ , the heat of vaporization of mercury must be subtracted. Kurbatoff<sup>35</sup> found the molecular heat of vaporization at the

boiling point (358° C) to be 13500 cal.  $U$  at 358° calculated from equation (2) is 69200, from half of which subtract 13500 giving 21100 cal. as heat of reaction between liquid mercury and oxygen gas at 358° C exclusive of external work. In order to rigidly compare with results obtained calorimetrically, this value must be calculated to room temperature by aid of equation expressing change of heat of reaction with temperature,

$$\frac{U_2 - U_1}{t_2 - t_1} = c - c' \quad (4)$$

where  $U_2 = 21100$  is heat developed at 358° ( $t_2$ ), and  $U_1$  at 18° ( $t_1$ );  $c' = 11.2$  cal. heat capacity of the solid oxide and  $c = 10.1$  cal., heat capacity of the reacting oxygen at constant pressure plus the liquid mercury; whence  $U_1 = 21500$  cal. The average of the calorimetric values is 21700 from which must be subtracted the external work  $\frac{1}{2} RT$  cal. giving 21400 cal. The agreement is excellent.

#### Calculation of the Equation of the Curve of the Dissociation Pressure

This may be done directly with the aid of the Nernst formula<sup>30</sup>

$$\log P = -\frac{\lambda_0}{4.571 T} + 1.75 \log T - \frac{\varepsilon}{4.571} T + C \quad (5)$$

in which the constants  $\lambda_0$ ,  $\varepsilon$ , and  $C$  may be found by taking the values of  $P$  at three different temperatures. From the data (a), (b), and (c) given above, we get

$$\lambda_0 = 24105 \quad \varepsilon = 0.004723 \quad C = 5.9461 \quad (6)$$

whence the equation of the curve becomes

$$\log P = -\frac{5273.5}{T} + 1.75 \log T - 0.001033 T + 5.9461 \quad (7)$$

We are now in a position to calculate the dissociation pressure of mercuric oxide at any temperature either from equation (3) or equation (7). Taking as our data in (3),  $U_0 = 76400$  and a pressure of 810 mm at 450° C, we obtain

as the pressure at 500° C 2395 mm. Substitution in (7) gives the same value, corresponding to a partial pressure oxygen 798 mm, while Pélabon's observed value is somewhat higher, 985 mm.

At lower temperatures, taking again as our data  $U_0 = 76400$  and a pressure of 231 mm at 400° C in (3), we obtain practically identical values from (3) and (7), at 200° C 0.10 mm, at 25° C  $1.9 \times 10^{-8}$  mm. Extrapolated values from Pélabon's formula give for 200° 0.04 mm and for 25°  $3 \times 10^{-12}$ , values smaller than the above, just as might be expected from the intersection of the curves as shown in Fig. 6.

It has been shown in distilling amalgams under reduced pressure with a slow current of air drawn through,<sup>10</sup> that the base metals are oxidized in the vapor phase. That mercury does not oxidize under these conditions (*i. e.*, 5 mm partial pressure oxygen and 200° C) is probably due to slow rate of reaction, as the partial pressures of mercury and oxygen in the still are much greater than are necessary to fulfil the equilibrium pressures as indicated by our calculation at 200°.

The extraordinarily low values of the dissociation pressure at room temperatures indicates that in the presence of mercury the oxide is perfectly stable in air. At the same time if no mercury is present, no pressure of oxygen, however great, could prevent theoretically some decomposition of the oxide, since there would be a vacuum to mercury vapor. Mercury then can oxidize under atmospheric conditions and it is merely a question of rate. If the explicit cause of the dirtying of mercury is to be found in the oxidation of the metal itself the role of the suboxide should be considered.

*Platinum as Catalyst.*—Finely divided platinum acts as a catalyzer for the dissociation of mercuric oxide but we have been unable to get concordant quantitative results with it. The pressures experimentally obtained by its use in either the static or submerged bulb methods were always too high, while the inherent experimental errors, aside from incomplete

expulsion of air, were due to the slow evolution of the gases and were in the opposite direction. There can hardly be any question but that platinum dissolves both of the dissociation products to some extent. It was hoped that the platinum would soon become saturated and then we should obtain correct values but this was apparently impossible.

Now it can be shown that if either of the products of dissociation is in excess, then the *total pressure* will be increased, for if mercuric oxide decomposes according to the following equation,

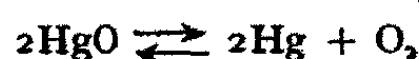

then the mass law requires that

$$\frac{C_{\text{Hg}}^2 \times C_{\text{O}_2}}{C_{\text{HgO}}} = \text{constant}$$

where C represents concentration. Assuming the densities of the gases to be normal we may substitute their partial pressures for concentrations. Let  $p$  be the partial pressure of oxygen and  $m$  that of mercury, then since the pressure of the solid is a constant

$$pm^2 = K \quad (8)$$

where K is the dissociation constant. Let P be the total pressure, then  $P = p + m$  and

$$P = \frac{K}{m^2} + m \quad (9)$$

$$\frac{dP}{dm} = -\frac{2K}{m^3} + 1$$

The theorem of maxima and minima requires, in order for P to have a minimum value,  $\frac{dP}{dm} = 0$ .

$$-\frac{2K}{m^3} + 1 = 0 \quad (10)$$

$$m^3 = 2K = 2pm^2 \quad (11)$$

$$m = 2p \quad (12)$$

Equation (12) is satisfied only when the mercury vapor and oxygen are in equivalent proportions. This proof can

be made perfectly general, and thus we arrive at the interesting conclusion that the smallest possible *total* pressure of any number of gases uniting to form one definite solid and in equilibrium with that solid, occurs when the gases are in the same proportions in which they exist in the solid phase. The results of Isambert<sup>37</sup> with ammonium carbamate accord with this conclusion.

*The Identity of the Red and Yellow Oxides.*—There has been some controversy in the literature over the identity of the red and yellow oxides. Measurements of electromotive force in various types of cells<sup>38</sup> have led Cohen<sup>39</sup> to the conclusion that they are modifications and not identical, having apparently different contents of energy. But Ostwald<sup>40</sup> contends that the small electromotive force observed is due to the different rates of solubility of the forms owing to the much finer state of division of the yellow.<sup>40'</sup> This view is borne out by Varet's<sup>41</sup> determination of their identical heats of formation. Additional confirmation is found in the only slightly different solubilities of the two forms in the alkali-halide solutions,<sup>42</sup> in oxalic acid,<sup>43</sup> and in pure water.<sup>44</sup>

More recently Schoch<sup>45</sup> has concluded that the red and yellow are not identical, based mainly on qualitative distinctions of color and crystalline form and a difference in their dissociation pressure. He employed a static instrument consisting essentially of a bulb containing the oxide to which was attached a capillary tube ending in an open manometer. The apparatus was arranged so that it could be exhausted and the construction was such that the condensation of mercury was minimized. The results are discordant and much higher than our values for both the red and the yellow. It is stated that ground red oxide exerts a greater tension than coarse oxide and that the yellow oxide gives a pressure of near an atmosphere at 310° while the finely ground red gives only half as much. It is also stated that "the yellow oxide shows its own proper tension only for a short time when first heated." This statement seems to be based upon the fact that a sample showed on first heating a pressure of 660 mm. It was then



allowed to cool, the apparatus reexhausted, and when heated up again to about the same temperature showed a pressure of only 200 mm. The conclusion drawn is that the initial heating converted it into the red variety since its pressure fell towards that assumed for the red. Is it not more probable that the samples used by Schoch contained enough impurity, possibly in the shape of occluded gases, to account for the high values obtained? The lower pressure obtained for the yellow on reheating may have been due to the removal of some of the gaseous impurity by the exhaustion of the apparatus between experiments, and seems to us to be a more probable explanation of the facts than transition into the red form. We have heated the yellow oxide for several hours at  $475^{\circ}$  without noting any change in color, after cooling. Its rate of decomposition without a catalyst is not noticeably different from the red.

We have made a series of measurements of the dissociation pressure of the yellow oxide by our static method with ferric oxide as catalyst. This static method permits the removal of volatile impurities which is an important point in view of the possible serious errors of most static instruments. The resulting curve coincides with the red and confirms Ostwald's identity theory. The data upon which this conclusion is based follows:

KAHLBAUM'S YELLOW OXIDE AND  $\text{Fe}_2\text{O}_3$ 

° C	Total pressure mm	Partial pressure oxygen	
		(Observed)	(Calc.)
477.1	1474	491.3	494
448.0	780	260	258
415.0	342	114	113

### Summary

1. It has been shown that the decomposition of mercuric oxide is catalyzed by platinum and certain metallic oxides.

2. The dissociation pressure of mercuric oxide has been measured from 360° C to 480° C.
3. Pressures calculated to 200° C and room temperature have shown that the oxide is stable in the presence of mercury in the air, even under greatly reduced partial pressure of oxygen.
4. Mercury may oxidize under atmospheric conditions, it is a question of rate, and the rate is evidently markedly affected by catalyzers.
5. The heat of formation as calculated from the dissociation pressure has been found to agree with the calorimetric results.
6. The dissociation pressure of the yellow oxide has been shown to be the same as that of the red oxide, confirming the identity theory.
7. It has been shown that the mass law requires that a solid which dissociates completely into gases is in equilibrium with those gases at a minimum total pressure when none of the gaseous components are in excess.

Princeton, N. J.

#### REFERENCES AND NOTES

1. Hulett: *Phys. Rev.*, **33**, 310 (1911).
2. Roscoe and Schorlemmer: "Treatise on Chemistry," (1905) II, 666.
3. "Traité de Chimie," Part I, Chap. 3. See Roscoe and Schorlemmer, I, 52.
4. *Ber. chem. Ges. Berlin*, **6**, 11 (1873).
5. *Comptes rendus*, **77**, 123 (1873).
6. *Chem. News*, **44**, 189 (1881).
7. *Mémoires de Société de Bordeaux*, [5] **5**, 68 (1901).
8. *Jour. Chem. Soc.*, **53**, 80 (1888).
9. *Comptes rendus*, **128**, 825 (1899), for details see "Mémoires de la Société des Sciences physiques et naturelles de Bordeaux [5]," **5**, 69 (1901).
10. *Loc. cit.*
11. See Foote and Smith: *Jour. Am. Chem. Soc.*, **30**, 1344 (1908); also Lewis: *Ibid.*, **28**, 139 (1906).
12. Smith and Menzies: *Jour. Am. Chem. Soc.*, **32**, 1416 (1910).
13. See Debray's criticism of Myers, location cited.
14. *Jour. Am. Chem. Soc.*, **32**, 1412-1434, 1448-1459 (1910).
15. V. Meyer and Freyer: *Ber. chem. Ges. Berlin*, **25**, 662 (1892).
16. Bodenstein: *Zeit. phys. Chem.*, **46**, 725 (1903).

17. Sodeau: *Jour. Chem. Soc.*, 1067 (1902).
18. *Zeit. phys. Chem.*, 52, 310 (1905).
19. *Phys. Rev.*, 33, 307 (1911).
20. *Ibid.*, 32, 276 (1911).
21. "High Temperature Gas Thermometry," Carnegie Institute Publication, 157, p. 118.
22. *Ibid.*, p. 117.
23. *Jour. Am. Chem. Soc.*, 32, 907 (1910).
25. Smith and Menzies: *Jour. Am. Chem. Soc.*, 32, 1419 (1910).
26. *Ann. Chim. Phys.*, [3] 15, 129 (1845).
27. For bibliography of this method for vapor pressure of solutions see Krauskopf: *Jour. Phys. Chem.*, 14, 492 (1910). For vapor pressure of mercury see Pfaundler: *Wied. Ann.*, 63, 36 (1897); also Morley: *Phil. Mag.*, 7, 662 (1904).
29. For detailed description and construction of these glowers see Laird and Hulett. *Trans. Am. Electrochemical Soc.*, 22, 352 (1912).
30. *Jour. Am. Chem. Soc.*, 27, 1415 (1903).
31. *Ibid.*, 28, 152 (1906).
32. "Thermochemistry."
33. *Zeit. phys. Chem.*, 2, 27 (1888).
34. *Ann. Chim. Phys.*, [7] 8, 100 (1896); *Comptes rendus*, 120, 620, 921.
35. *Zeit. phys. Chem.*, 43, 104 (1903).
36. "Theoretical Chemistry," (1911), Bk. IV, Chap. V, p. 19.
37. *Comptes rendus*, 93, 731 (1881).
38. Glazebrook and Skinner: *Phil. Trans.*, 183, 367; *Proc. Roy. Soc.*, 51, 60 (1892). Ostwald: *Zeit. phys. Chem.*, 18, 159 (1899).
39. *Zeit. phys. Chem.*, 34, 69 (1900).
40. *Ibid.*, 34, 495 (1900).
- 40'. *Ibid.*, 37, 385-406 (1901).
41. *Comptes rendus*, 120, 622, 1114 (1895).
42. Bersch: *Zeit. phys. Chem.*, 8, 383 (1891).
43. Koster and Stork: *Rec. Trav. chim. Pays. Bas*, 20, 394 (1901).
44. Schick: *Zeit. phys. Chem.*, 42, 155 (1902).
45. *Am. Chem. Jour.*, 29, 319 (1903).

## ELECTRICAL CONDUCTIVITY OF SOLUTIONS OF MOLYBDENUM PENTACHLORIDE

STEWART J. LLOYD

While searching for an organic solvent from which metallic molybdenum might be deposited electrolytically, molybdenum pentachloride was dissolved in various solvents and the conductivity of the resulting solutions examined. Although the primary object of the work was not attained, as lower chlorides and oxychlorides were deposited instead of the metal itself, the results of the conductivity measurements were somewhat interesting, and in view of the importance assumed by non-aqueous solutions in the general study of electrolytic dissociation they are given here, together with a few other measurements of related interest.

Molybdenum pentachloride was prepared by passing dried chlorine gas over powdered molybdenum at the temperature of the combustion furnace and collecting the chloride as it sublimed over. The powdered molybdenum of commerce is far from pure, containing considerable quantities of one or more oxides, as well as of iron, and considerable trouble was experienced in obtaining a pure product. The simplest way was finally found to be to pass a stream of chlorine over the powder until the appearance of the sublimed material showed that no more iron and oxychloride was coming over, then to continue the chlorination, collecting and using the distillate. Iron chloride, and the molybdenum oxychlorides invariably pass over first, at a much lower temperature than the pentachloride.

Prepared in this way the chloride is almost black, and highly crystalline. It takes up moisture with great readiness from the air, yielding hydrochloric acid and an oxychloride, and great care is necessary to keep it dry. In making the conductivity measurements the chloride was distilled directly into the weighed conductivity cell.

Molybdenum pentachloride proved to be very soluble in

all the organic solvents used, though its conductivity in them varied within wide limits, the acetates (methyl and ethyl), giving solutions which conduct almost as well as do aqueous solutions of common salts, while sulphur chloride and carbon tetrachloride solutions of the pentachloride do not conduct appreciably. A curious relation was found to hold between the color of the solutions and the change in molecular conductivity on dilution. Molybdenum pentachloride dissolves in organic solvents with the production of one of two colors, a beautiful green ranging from nickel in the acetates to olive in the benzoates, or a deep red-brown. Solutions having a green color showed a decrease in molecular conductivity on dilution, those with a red-brown color either did not conduct appreciably or showed an increase in molecular conductivity when diluted. In the case of acetone, the molecular conductivity first decreased and then increased, the solution remaining green throughout.

The measurements were made in a conductivity cell of the usual type, at a temperature of 18° C.  $\mu$  and V have their usual meaning.

Solvent	Methyl acetate	Solvent	Ethyl acetate
$\mu$	V	$\mu$	V
5.1	2600	1.12	3200
3.9	5200	0.91	6400
3.33	10400	0.84	12800
2.91	20800	0.82	25600
2.88	41600	—	—

Both of these solvents gave beautiful nickel green solutions with the pentachloride. It will be noticed also that the molecular conductivity diminished with dilution for both of them. The methyl acetate solution was almost as conductive as the standard potassium chloride, although it was far from saturated. It will not be surprising if methyl acetate proves to be a solvent of some value for the electrodeposition of metals.

In isobutyl acetate and in methyl benzoate, molybdenum pentachloride produced olive green solutions with but slight conductivity. In both cases the molecular conductivity decreased on dilution, but satisfactory measurements were not made, on account of the high resistance.

Solvent $\mu$	Acetone V	Solvent $\mu$	Benzaldehyde V
2.02	2925	2.4	2900
1.99	5850	2.15	5800
2.36	11700	2.05	11600
2.90	23400	1.92	23200
3.43	46800	—	—
3.75	103600	—	—

The acetone solution was deep green, the benzaldehyde olive green. On account of the difficulty of keeping the benzaldehyde free from benzoic acid, no great accuracy is claimed for the results obtained with it. Acetone was the only solvent used for which a minimum of molecular conductivity was observed.

Solvent $\mu$	Pyridine V	Solvent $\mu$	Glycerine V
1.14	3150	0.92	2509
1.42	6300	1.08	5018
1.79	12600	1.45	10036
2.28	25200	1.95	20072
3.12	50400	—	—

Both of these solutions were reddish brown in color, and in both the molecular conductivity increased regularly on dilution.

Acetic anhydride gave a green solution, the molecular conductivity of which decreased on dilution, while sulphur chloride ( $S_2Cl_2$ ), carbon tetrachloride, nitrobenzene, nitrotoluene, ethyl bromide, quinoline, and carbon disulphide, all gave dark red solutions, which were practically non-conducting.

Fig. 1 gives the curves made by plotting the molecular conductivity against the logarithm of the dilution for a number of the solutions. It is probable that the solutions which show a molecular conductivity decreasing with dilution really possess a minimum, after which the molecular conductivity increases in the usual way. Acetone actually shows this,

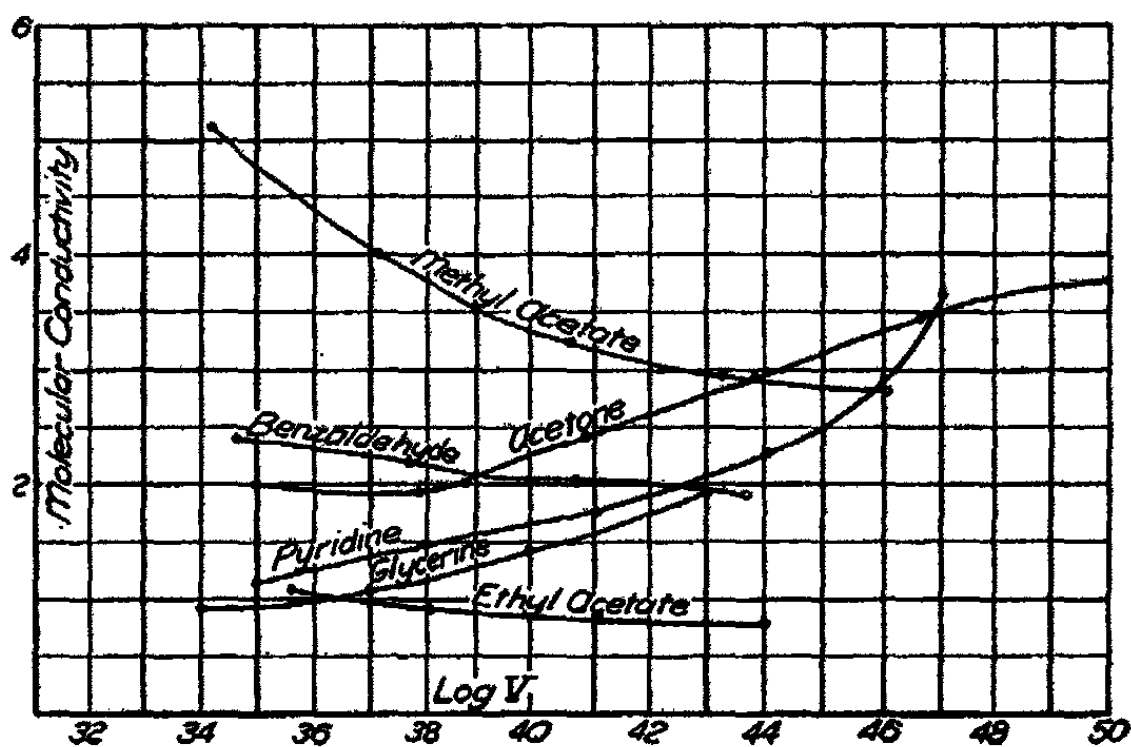

Fig. 1

and it appears that methyl and ethyl acetate solutions approach it. Similar phenomena have been noted by Walden,<sup>1</sup> Franklin and Kraus,<sup>2</sup> and by Franklin and Gibbs<sup>3</sup> for solutions in liquid ammonia, and especially in methylamine.

University of Alabama  
March, 1913

<sup>1</sup> Walden: Zeit. phys. Chem., 54, 141 (1906).

<sup>2</sup> Jour. Am. Chem. Soc., 27, 204 (1905).

<sup>3</sup> Ibid., 29, 1389 (1907).

## THE ELECTROCHEMISTRY OF LIGHT, X<sup>1</sup>

BY WILDER D. BANCROFT

In 1818, Grotthuss<sup>2</sup> formulated two laws of photochemistry:

I. Only those rays of light which are absorbed can produce chemical action.

II. The action of a ray of light is analogous to that of a voltaic cell.

The first of these laws is usually attributed to Draper who rediscovered it. In the preceding papers of this series, I have shown the usefulness of the second law as a working hypothesis. The time has now come when both of these laws can be worded more broadly. The general understanding of the first law is that only those rays of light, which are absorbed, can produce chemical action but that all of the absorbed rays are not necessarily active. For instance, Byk<sup>3</sup> points out that Fehling's solution is decomposed by light having a wave-length somewhat less than  $400\mu\mu$  while it is not sensitive to light corresponding to the absorption band in the red and yellow. There seems to be no sound, theoretical reason for distinguishing two kinds of absorption bands, one of which corresponds to a conversion of light into heat only, while, with the other, we have a partial conversion of light into chemical energy. It is much more rational to assume that, in some cases, the action of the light is not sufficient to produce measurable chemical change under the conditions of the experiment. This is in harmony with what we already know, namely, that many substances are sensitive to light only when suitable depolarizers<sup>4</sup> are present. I therefore propose changing the first law to make it read that all radiations tend to decompose the substances which absorb them.<sup>5</sup> Whether any measurable

<sup>1</sup> Based on a paper read before the Eighth International Congress of Applied Chemistry in New York, September, 1912.

<sup>2</sup> Cf. *Jour. Phys. Chem.*, 12, 212 (1908).

<sup>3</sup> *Zeit. phys. Chem.*, 49, 659 (1904).

<sup>4</sup> Bancroft: *Jour. Phys. Chem.*, 12, 230 (1908).

<sup>5</sup> Bancroft: *Jour. Am. Chem. Soc.*, 33, 92 (1911).



change takes place depends upon other conditions. With some silver salts or with Eder's solution of mercuric oxalate, we get visible decomposition by light. With chromium salts we get no measurable change unless some reducing agent is present but it can be a very weak reducing agent. With some substances, the action of light causes fluorescence or phosphorescence, thus indicating the occurrence of chemical changes even though there may be no appreciable decomposition. With a copper sulphate solution there is no apparent effect due to light and yet it is certain that the difference in the light sensitiveness of a copper sulphate and a silver sulphate solution is merely a difference in the strength of the depolarizer needed. This point of view has been confirmed by some experiments made recently in my laboratory. Leighton<sup>1</sup> showed that Fehling's solution could be reduced by red light provided a suitable amount of hydroquinone was added as depolarizer. Bennett<sup>2</sup> showed that a copper sulphate solution is reduced by light when a dilute solution of phosphorus in ether is present. In this case we do not get metallic copper as an end-product because the copper reacts with the excess of phosphorus to form phosphide. Luther and Michie<sup>3</sup> state that uranous sulphate in acid solution reduces copper sulphate to metal. By taking a dilute enough solution of uranous sulphate it would easily be possible to arrange the concentrations so that metallic copper would be formed in the light and not in the dark.

When formulating the improved form of Grotthuss' first law, I used the word radiations instead of light, intentionally because this enables me to include cathode rays, etc., which some people might object to classifying as light. They must be included because the same general laws apply in all these cases.

While we now postulate that all radiations, which are absorbed, tend to produce chemical change, we do not of course

<sup>1</sup> Jour. Phys. Chem., 17, 205 (1913).

<sup>2</sup> Ibid., 16, 782 (1912).

<sup>3</sup> Zeit. Elektrochemie, 14, 826 (1908).

postulate that different wave-lengths have the same effect. In the case of Fehling's solution, the ultra-violet rays are able to cause decomposition without the addition of a depolarizer, while the red rays cannot. The absorption of light by bromine is much more marked in the greenish-blue and the blue than it is in the yellow-green and the orange; but it is the rays corresponding to the latter absorption which are the most effective in bringing about the reaction between bromine and toluene.<sup>1</sup> The efficiency of particular wave-lengths is a matter about which we can make no predictions at present. Until we get some sort of theory in regard to the relation between the intensity of an absorption and the change of chemical potential, we can do nothing more than recognize the fact that all radiations which are absorbed tend to cause chemical change; but that the efficiency of any particular wave-length of light depends upon factors which have not as yet been formulated clearly.

While the statement that light acts like a voltaic cell has proved to be an excellent working hypothesis for cases involving oxidation and reduction, its usefulness is not so striking in cases involving allotropic modifications or polymerization. It is true that Berthelot<sup>2</sup> has shown that soluble sulphur can be obtained at the anode by electrolyzing a solution of hydrogen sulphide and that insoluble sulphur can be obtained at the cathode by electrolyzing a solution of sulphuric or sulphurous acid; but this is not really analogous to the action of light because light produces insoluble sulphur by acting on sulphur and not on hydrogen sulphide or sulphurous acid. It is also very probable that what one gets during electrolysis depends primarily on the conditions under which the sulphur is set free and that insoluble sulphur is not electropositive sulphur in any proper sense of the term. At one time that did not disturb me, but, at that time, I expected to be able to prepare dianthracene electrolytically.<sup>3</sup> We have since tried to do this

<sup>1</sup> Schramm and Zakrzewski: Monatsheft, 8, 299 (1887).

<sup>2</sup> Ann. Chim. Phys., (3) 49, 448 (1857).

<sup>3</sup> Trans. Am. Electrochem. Soc., 13, 257 (1908).

by dissolving anthracene in sulphuric acid and in other ways, but we have not been successful. Of course, it is possible that somebody else may succeed later in making dianthracene electrolytically; but nobody has done so as yet, and I am willing to abide by the results of this, admittedly crucial, test. It is also not absolutely satisfactory to have to say, in the case of organic substances, that light produces the same decomposition products that we should get if we could electrolyze the substance in question, which we know we cannot do. It sounds a little like the Gilbert and Sullivan problem: "If I can wheedle a knife or a needle, then why not a silver churn?"

There is another, more serious, objection to the Grotthuss generalization in its present form. The selective action of light is much more marked than the selective action of the current. We can take a solution containing cadmium and copper sulphates and we can precipitate metallic copper by regulating the voltage. We cannot, however, precipitate cadmium from that solution before the copper, though we can do it if we change to a cyanide solution. Suppose that we have two dyes of different colors which are oxidized about equally readily. By changing the wave-length of the light we can cause one dye or the other to oxidize in the air. So far as I know the only analogy to this in electrochemistry is the reduction of nitrates and nitrites.<sup>1</sup> At a smooth platinum cathode nitrite is reduced more readily than nitrate while the reverse is true at a spongy copper cathode. One difference between light and the electric current is that the current is a single reagent except in so far as the specific nature of the electrode may make a difference, while light is a mixture of reagents. Light of one wave-length may act on one substance and light of another wave-length on another, or lights of different wave-lengths may cause the same substance to react in different ways. This is not covered by the Grotthuss formulation and it is therefore necessary to make a more general statement.

---

<sup>1</sup> Müller and Spitzer: *Zeit. Electrochemie*, 11, 509 (1905).

I propose the following generalization as an improvement on the two laws of Grotthuss:

All radiations which are absorbed by a substance tend to eliminate that substance. It is entirely a question of chemistry whether any reaction takes place or what the reaction products are.

This is precisely analogous to the formulation which I have given<sup>1</sup> for electrolysis. "In the case of electrolysis the only specific action which we have to attribute to the current is that it tends to set free the anions at the anode and the cations at the cathode. What happens over and above that is a question of chemistry, depending on the reaction velocity and equilibrium relations in each particular case."

The formulation which I have given for the action of light covers the cases of oxidation and reduction as well as does the formulation of Grotthuss. What I wrote four years ago,<sup>2</sup> is equally applicable today: "The chemical effect of the light is merely to eliminate, if possible, the substance absorbing the light. Whether the elimination takes place as a result of oxidation or of reduction is a matter which is quite independent of the light and which depends on the nature of the depolarizer. If the depolarizer is a sufficiently strong reducing agent, we get reduction by light. If the depolarizer is a sufficiently strong oxidizing agent, we get oxidation by light. If it is not sufficiently one or the other, we get no action by light. A very good instance of the variable action of light is to be found in the case of mercurous chloride. In the presence of a sufficiently powerful reducing agent, light reduces mercurous chloride to metallic mercury. In the presence of a sufficiently powerful oxidizing agent, light oxidizes mercurous chloride to a mercuric salt. If there is no more suitable depolarizer, the mercurous chloride itself acts as a depolarizer and is changed to mercury and mercuric chloride."

When we come to the case of oxygen, we now find it all plain sailing. Light which is absorbed by oxygen tends to

<sup>1</sup> Bancroft: *Trans. Am. Electrochem. Soc.*, 8, 33 (1905).

<sup>2</sup> *Ibid.*, 13, 246 (1908).

eliminate the oxygen and we get the formation of ozone or of ions as the case may be. Light, which is absorbed by ozone, tends to convert the ozone back into oxygen. In this case we get light accelerating both reactions, but not the same light. It is easy to see, however, that we might have a case where the displacement of equilibrium in one direction by light might be small owing to low efficiency or to absence of certain wave-lengths, in which case light might apparently have very little effect on one modification, under the conditions of the experiment. This appears to be true with phosphorus. Ultra-violet light converts white phosphorus into red phosphorus; but nobody has hitherto noted any photochemical change of red phosphorus into white phosphorus. Such a change must take place at some temperature and with some wave-lengths of light. With the theory to guide him, Mr. Leighton has succeeded in converting red phosphorus into white phosphorus, using green light. It must be possible also to convert insoluble sulphur into soluble sulphur by means of light; but here we are hampered by experimental limitations in case the important rays are in the ultra-violet as they may well be. I know of no satisfactory method of obtaining approximately monochromatic light of any given wave-length and of high intensity. The amount of ozone obtained by the silent discharge is the difference between the amounts formed by waves shorter than  $300\mu$  and that decomposed by waves longer than  $300\mu$ . If the chemical action of the waves longer than  $300\mu$  had been somewhat more vigorous, or if that of the shorter waves had been somewhat less vigorous, we should not get any ozone by means of the silent discharge, even though ozone could still be made readily if the wave-lengths above  $300\mu$  could be shut off. The phosgene equilibrium offers an interesting illustration of the principle involved. Weigert<sup>1</sup> worked at too high a temperature ( $500^{\circ}$ ), and in glass vessels which cut off the ultra-violet light. He found no displacement of equilibrium

<sup>1</sup> *Drude's Ann.*, 24, 55, 243 (1907).

by light and he worked out a theory to account for this. Coehn and Becker<sup>1</sup> worked at room temperature with quartz tubes and found that  $\text{COCl}_2$  is decomposed chiefly by light having wave-lengths shorter than  $265\mu\mu$ . This was a particularly simple case because glass acted perfectly as a screen for the active rays while quartz did not. What we need is a general method. When we get a suitable way of getting ultra-violet light of any given wave-length, we shall undoubtedly be able to demonstrate the photochemical conversion of insoluble sulphur and of dianthracene into anthracene. The photochemical change of soluble sulphur into insoluble sulphur and of anthracene into dianthracene is covered by the formulation, which also foresees the possibility of certain rays causing anthracene to fluoresce<sup>2</sup> while others change it to dianthracene.

The results of this paper may be summed up as follows:

1. It is correct to say that only those rays which are absorbed produce chemical action; but it is incorrect to add that some absorbed rays have no tendency to produce chemical action.

2. The statement that light acts like a voltaic cell is not adequate to account for all the facts, though it has proved an admirable working hypothesis up to a certain point.

3. The most satisfactory formulation of the chemical action of light is that all radiations which are absorbed by a substance tend to eliminate that substance. It is a question of chemistry whether any reaction takes place and what the reaction products are.

4. Different radiations may cause the same substance to react in different ways.

5. We have, as yet, no theory which will enable us to predict the relative efficiencies of lights of different wave-lengths.

Since the Grotthuss formulation has now been superseded, this paper is the last one of this series. The future work on the chemical action of light will be published under a different title.

*Cornell University*

<sup>1</sup> Ber. chem. Ges. Berlin, 43, 130 (1910).

<sup>2</sup> Cf. Miss Stevenson: Jour. Phys. Chem., 15, 845 (1911).

## THE INTERNAL PRESSURES OF LIQUIDS

BY ALBERT P. MATHEWS

The fundamental significance of the constant "*a*" of van der Waals' equation makes its exact determination important.

Various methods have been proposed for the determination of this constant, but none of them are entirely satisfactory. In a recent paper<sup>1</sup> attention was drawn to a method by which it could be determined from the surface tension by the use of Thomas Young's formula,  $T = rK/3$ , combined with the law of Ramsay and Shields, and the values thus computed were shown to be closely similar for most substances to the values computed by van der Waals' method from the critical temperature and pressure, but in some cases they deviated considerably from his values. I found, also, that the values of the constant "*a*" obtained by this method were simple functions of the products of the molecular weight and the number of valences in the molecule and that they could be computed from these values. Inasmuch as the method used in computing "*a*" from the surface tension involved the value of the density at absolute zero, which was computed from Cailletet and Mathias' law of the rectilinear diameter, and involved, therefore, some uncertainty and was certainly too high, it was desirable to find a method of computing "*a*" directly from the surface-tension measurements.

The desire of finding such a method was stimulated by the present great uncertainty of the value of the internal pressures of liquids. Traube<sup>2</sup> has within the past few years computed the internal pressure for many liquids, but the results he has obtained are, in my opinion, unreliable because his method of computation involves the use of the value "*b*" the real molecular volume or co-volume, a very doubtful value. The values he finds for the internal pressure at zero degrees are, also, widely different from those computed by the use of "*a*" found

<sup>1</sup> Mathews: Jour. Phys. Chem., 17, 154 (1913).

<sup>2</sup> Traube: Zeit. phys. Chem., 68, 291 (1909).

at the critical temperature; and in some cases they are not more than half those calculated recently by Lewis<sup>1</sup> from the latent heats of expansion of liquids.

Walden,<sup>2</sup> also, has recently calculated the value of "*a*" and the internal pressure from the surface tension. His calculation is, however, almost wholly empirical.

It is based, first, on Stefan's conclusion<sup>3</sup> that it takes one-half the work to move a particle into the surface which is required to carry it all the way to the vapor; and, second, upon an empirical relationship found by Walden between the surface tension and the molecular latent heat at the boiling point. It is, however, by no means certain that Stefan's conclusions are correct and his reasoning does not carry conviction. There is, also, probably an error in the assumption that the molecules do not change in size on passing from the liquid to the vapor and that the latent heat of vaporization represents only the work done in overcoming molecular cohesion. Finally Walden's values for "*a*" resemble Traube's. "*a*" is always much less than when computed by van der Waals' method from the critical data and much less than the values of Lewis. The values which Walden has obtained are about two-thirds the values given in this paper.

Values still smaller have been computed by Davies<sup>4</sup> from the latent heat of vaporization. The values he obtains are only about one-third those of Lewis. Winther<sup>5</sup> has still other results.

Many modifications of van der Waals' equation have been proposed in which "*a*" was considered variable with the temperature and "*b*" more, or less, constant. These attempts have not been fruitful. It is far more probable that "*b*," the volume correction, varies with temperature and volume and that "*a*," which is the "mass" factor of the cohesion, is

<sup>1</sup> Lewis: *Phil. Mag.*, [6] 25, 61 (1912).

<sup>2</sup> Walden: *Zeit. phys. Chem.*, 66, 385 (1909).

<sup>3</sup> Stefan: *Wied. Ann.*, 29, 655 (1886).

<sup>4</sup> Davies: *Phil. Mag.*, [6] 24, 422 (1912).

<sup>5</sup> Winther: *Zeit. phys. Chem.*, 60, 603 (1907).



constant. "a," indeed, as van der Waal's has repeatedly shown, should be considered constant unless association, or quasi-association, occurs. "a" contains the factor  $N^2$ ,  $N$  being the number of molecules in the volume,  $V$ , hence any association will lower "a" by this factor.

The wide divergence of these various values proposed for the internal pressure is shown in Table I expressing the internal pressure in atmospheres at zero degrees, except in the case of Walden where the values are for the boiling points and Davies for 15° C.

TABLE I

Substance	Davies 15°	Traube 0°	Walden b. p.	v. d. Waals 0°	Lewis 0°	Winther
Benzene	1102	1380	1570	2494	2639	1792
Toluene	1188	1180	1340	2228	2847	—
Cymene	661	—	—	—	2718	—
Ether	778.9	990	{1150} {1210}	1723	1932	1220
CCl <sub>4</sub>	1076	1305	1490	2205	2518	1680
CS <sub>2</sub>	1683	1980	2170	3363	2917	—
Et acetate	—	2210	{1280} {1340}	—	2466	1486

In this paper are given the values of "a" obtained in several quite different ways, all of which yield closely agreeing results.

1. The first method is a computation from the surface tension. The assumption involved in this method is the depth of the surface film expressed in the number of molecular layers. That the assumption is correct is proved by the outcome.

2. The second method is a modification of Thomas Young's method combined with the law of Eötvös as developed in my former paper, but with certain corrections.

3. In the third method "a" is computed from van der Waals' equation at the critical temperature, the assumption being made that in all normal substances  $b_c = 2V_o = 2V_c/S$ ,  $S$  being the critical coefficient and equal to  $RT_c/V_cP_c$ .

4. In the fourth method "a" is computed from the internal

latent heat of vaporization close to the critical temperature. The only assumption made here is that Mills' or Dieterici's formula for the internal latent heat is more correct close to the critical temperature than the internal latent heat computed by Biot's formula.

5. Finally "a" is computed from the number of valences and the molecular weight by the formula:  $a = C(M \times \text{Val})^{2/3}$ .

#### 1. Computation of "a" from the Surface Tension

The surface film is determined by the difference of cohesive attraction in the vapor and liquid. The surface energy must, hence, be a function of the difference in cohesive energy in the liquid and vapor, or of the expression  $a(1/V_l - 1/V_v)$ . This cohesive energy has been lost in passing the liquid through the surface layer which separates the two states and should be calculable from the surface tension.

Suppose we have a sphere of a gram mol of a liquid in contact at all points with its saturated vapor. Its density is uniform except in the surface film where it decreases by a series of steps from liquid to vapor density. The surface film may be conceived as a series of concentric shells, each a molecular diameter thick, and each outer one less dense than the inner until the state of uniform vapor density is reached. Furthermore, on passing from one of these molecular shells lying within to the one next beyond it, always the same amount of cohesive energy will be lost, if the density diminishes uniformly from shell to shell.

The surface tension  $T$ , is the tension along a line 1 cm. in length in the surface film and one molecular layer deep. It represents the force necessary to stretch the surface, that is to rupture one of these shells, and thus drag one, or more, molecules from the inner core of uniform density into the first concentric shell; and of course the force necessary to drag molecules from the first shell to the second, and from the second to the third and so on, since the same force is necessary to drag molecules from each inner shell to the next outer. This tension,  $T$ , is numerically equal, also, to the surface tension

energy per square cm. of the surface film. For each concentric shell of the surface one molecular diameter deep, the surface energy is, then,  $T$  times the surface, or  $TV_1^{2/3}$ ; and the total energy in the surface or  $\sigma$ , will be equal to this amount multiplied by the number of shells, which we shall represent by the letter  $n$ , thus we have the equation:

$$(1) \quad \sigma = TV_1^{2/3}n$$

If now a gram mol of liquid passes from liquid to vapor it must pass through this surface in which surface energy is gained at the expense of the cohesive energy which is lost. To determine the total amount of energy which is thus changed in passing the whole gram mol through the surface, it is only necessary to determine how many times we shall have to make a new surface shell until the whole of the gram mol has passed through. Since the total number of molecules in the gram mol is  $N$ , and there are in a surface shell  $N^{2/3}$  molecules, we shall have to make a new surface  $N/N^{2/3}$  times, or  $N^{1/3}$  times. The total energy then which will be gained as surface tension energy will be  $\Sigma$ , or

$$(2) \quad \Sigma = TV_1^{2/3}N^{1/3}n.$$

This same value may be obtained, also, in the following way: The surface tension measures the force necessary to overcome the surface tension pressure along a line 1 cm long and a molecular diameter deep. The surface-tension pressure per sq. cm acting in the plane of the surface is hence  $T/v^{1/3}$ ,  $v$  being the volume of a single molecule. Multiplying numerator and denominator by  $N^{1/3}$  we have the pressure per square cm  $N^{1/3}T^{1/3}/V_1^{1/3}$ . If this pressure work through the volume  $V_1$ , the volume of one gram mol, we have the surface tension energy if a whole gram mol were present as a surface shell, or  $N^{1/3}TV_1^{2/3}$ . Multiplying this by the number of shells, or  $n$ , we have our former expression.

Equation (2) contains the unknown factor " $n$ ," that is the number of layers one molecular diameter thick constituting the surface film. Since I knew of no way of measuring this,

the following assumption was made based on van der Waals' conclusion that the surface film is infinitely thick at the critical temperature. At absolute zero, where the molecules are presumably in contact, it may be assumed that the surface film is only a single molecular diameter deep. At the critical temperature, on the other hand, it must be infinitely deep. That is, no matter how many layers of molecules one passes over, one can never, at that temperature, get to a region of differing density. Between absolute zero and the critical temperature the depth of the surface film must lie between these two values, increasing with the temperature, and presumably in all normal substances at corresponding temperatures it will be the same number of molecular layers thick. I accordingly made the guess that it would be equal to  $(T_c/(T_c - T))^{2/3}$  molecular diameters since this fraction is equal to  $(d_o/(d_i - d_v))^2$  (see page 617). This guess turned out to be correct if Eötvös surface-tension figures are used, but if Ramsay and Shields' are taken the fraction must be raised to the 0.76 power and even then the value of "a" computed by this assumption runs down near the critical temperature. Since Eötvös measured the surface tension by a method which entirely avoided any assumption as to the angle of contact and Ramsay and Shields used the capillary method, which involves such an assumption, I believe Eötvös figures and his statement of the law is to be preferred. That his formula of  $TV_1^{2/3} = 2.27(T_c - T)$  is to be preferred on other accounts is shown by the calculations which follow:

The total surface energy gained by passing a gram mol through the surface is hence:

$$(3) \quad \Sigma = TV_1^{2/3}N^{1/3}(T_c, (T_c - T))^{0.76} \text{ ergs; or}$$

$$(4) \quad \Sigma = TV_1^{2/3}N^{1/3}(T_c, (T_c - T))^{2/3} \text{ ergs.}$$

Formula (4) is to be preferred, when the surface tension is measured by methods which do not involve the angle of contact.

We only have left to find the relation between the amount of energy thus lost and the difference in the cohesive energy

in a gram mol of liquid and vapor, respectively. I think that the total surface-tension energy must be one-third of the total difference in cohesive energies in equal weights of the two phases separated by the surface. The energy in the surface is an expression of the difference in cohesive pressure in one direction only, whereas the two phases differ in their cohesion in three dimensions. That the value one-third is correct is shown by the computations which follow. The value one-third was that adopted also by Young more than a century ago, but his reasoning is so condensed that it is hard to follow. His statement is as follows:<sup>1</sup>

“Upon these grounds we may proceed to determine the actual magnitude of the contractile force derived from a given cohesion extending to a given distance. Supposing the corpuscular attraction equable throughout the whole sphere of its action, the aggregate cohesion of the successive parts of the stratum will be represented by the ordinates of a parabolic curve; for at any distance  $x$  from the surface, the whole interval being  $a$ , the fluxion of the force will be as  $dx(a - x)$ , since a number of particles proportional to  $dx$  will be drawn downwards by a number proportional to  $a$ , and upwards by a number proportional to  $x$ , and the whole cohesion at the given point will be expressed by  $ax - x^2/2$ ; and this at last becomes  $a^2/2$ , which must be equal to the undiminished cohesion in the direction of the surface. Consequently the difference of the forces acting on the sides of the elementary cube will everywhere be as  $a^2/2 - ax + x^2/2$  and the fluxion of the whole contractile force will be  $dx(a^2/2 - ax + x^2/2)$ , the fluent of which when  $x = a$  becomes  $a^3/6$ , which is  $1/3$  of  $a \times a^2/2$ , the whole undiminished cohesion of the stratum.”

“We may, therefore, conclude, in general, that the contractile force is one-third of the whole cohesive force of a stratum of particles equal in thickness to the interval to which the primitive equable cohesion extends,” or  $T = aK/3$ .

Accepting this coefficient of  $1/3$  of Young in place of that of

<sup>1</sup> Young, T: “Article on Cohesion,” collected works, p. 460.

$\frac{1}{2}$  of Stefan, or  $\frac{3}{20}$  as computed by Lord Rayleigh, we have the complete formula

$$(5) \quad a(1/V_1 - 1/V_v)/3 = TV_1^{2/3}N^{1/3}(T_c/(T_c - T))^{2/3}.$$

Changing to density in place of volume on the left hand side we have

$$(6) \quad a = 3TV_1^{2/3}N^{1/3}M(T_c/(T_c - T))^{2/3}/(d_1 - d_v);$$

or if Ramsay and Shields' surface-tension figures are used

$$(7) \quad a = 3TV_1^{2/3}N^{1/3}M(T_c/(T_c - T))^{0.76}/(d_1 - d_v).$$

The result is given in dynes for gram mol quantities.  $M$  is the molecular weight;  $d_1$  and  $d_v$ , liquid and vapor density, respectively;  $N$ , the number of molecules in a gram mol, is  $6.21 \times 10^{23}$ ;  $T$  is the surface tension in dynes;  $V_1$ , the volume of a gram mol at temperature,  $T$ .

From the foregoing it appears that  $\frac{1}{3}$  of the internal latent heat of vaporization is due to the cooling caused by the increase of the surface brought about by the transfer of molecules from the region of uniform density into the surface, and their passage through the surface.

In Table 2, I have given the calculation of " $a$ " by formula (7) for a number of substances using Ramsay and Shields', or Ramsay and Acton's or Renard and Guye's surface-tension determinations and the densities from S. Young's<sup>1</sup> recent work.

In Table 2 the constancy of " $a$ " is shown to be good for normal substances, except near the critical temperature where it generally falls off somewhat. This may be due to the inaccuracy of the surface tension close to the critical temperature, but it is more probably due to the fact that the thickness of the surface layer in molecular diameters is not properly represented by the expression  $(T_c/(T_c - T))^{0.76}$  and possibly to the influence of the angle of contact.

There is in general a tendency of the value of " $a$ " to rise except near the critical point, and this tendency is most pronounced in an associating substance such as ethyl alcohol.

The agreement is admirably clear to the critical temperature

<sup>1</sup> Young, S: Proc. Roy. Dublin Soc., 12, 374 (1910).

if the computation is made by Eötvös formula, for  $TV_c^{2/3}$  in the manner shown farther on (Table 6).

I may repeat, to make the point quite clear, that I think by taking the value  $(T_c/(T_c-T))^{0.70}$  in place of the theoretical value  $(T_c/(T_c-T))^{2/3}$  for these surface-tension measurements we offset, at least approximately, some constant source of error, possibly the angle of contact, involved in the determination of the surface tension by the capillary method. The opinion has been expressed by others that the error due to the neglect of the angle of contact, or the assumption that it is zero, will increase with the temperature.

TABLE 2  
"a" in dynes for a gram mol computed by formula (7)

Methyl formate		Ethyl acetate		Benzene	
$t^\circ$	$a \times 10^{-13}$	$t^\circ$	$a \times 10^{-13}$	$t^\circ$	$a \times 10^{-13}$
20	1.217	+20	2.338	11.2	2.214
40	1.224	80	2.366	46	2.220
60	1.228	100	2.366	80	2.220
80	1.233	120	2.370	120	2.235
100	1.237	140	2.367	160	2.242
120	1.237	160	2.368	200	2.242
140	1.231	180	2.368	240	2.225
160	1.218	200	2.353	260	2.179
180	1.193	220	2.355	270	2.081
200	1.058	240	2.193	280	1.521
210	0.885	245	2.107	288.5	$T_c$
214	$T_c$	250.1	$T_c$	—	—
Chlorbenzene		Carbon tetrachloride		Ether	
9.5	2.944	11.8	2.393	-89.2	2.038
45.6	2.947	46	2.404	+20	2.044
77.1	2.962	80	2.387	40	2.039
150	2.958	120	2.405	60	2.072
180	2.965	140	2.411	70	2.023
200	2.975	160	2.422	80	2.021
220	2.977	200	2.431	100	2.025
260	2.984	220	2.401	110	2.023
310	2.977	240	2.344	120	2.020
359.2	$T_c$	260	2.187	140	1.990
—	—	270	2.483	160	1.918
—	—	283	$T_c$	193	2.745
—	—	—	—	193.8	$T_c$

TABLE 2—(Continued)

Methyl butyrate		Cymene		Anisol		Toluene	
<i>t</i>	$a \times 10^{-13}$	<i>t</i>	$a \times 10^{-13}$	<i>t</i>	$a \times 10^{-13}$	<i>t</i>	$a \times 10^{-13}$
10	2.706	11.9	4.982	11.1	3.424	13.1	2.744
46.2	2.964	31.7	5.013	33.5	3.452	29.1	2.788
78.2	3.005	74.5	5.026	88	3.471	78.2	2.827
100	3.040	108.9	5.055	119	3.486	132.5	2.860
132.5	3.110	134.9	5.075	147.9	3.498	—	—
185	3.073	163.4	5.143	—	—	—	—
210	3.049	—	—	—	—	—	—
238	3.093	—	—	—	—	—	—
281.3	$T_c$	—	—	—	—	—	—
Piperidine		$CS_2$		$CHCl_3$		Methyl acetate	
15.2	2.638	9.7	1.277	10.2	1.837	10	1.719
46.6	2.664	46	1.222	45.5	1.860	46.2	1.727
78.4	2.672	61	1.434	77.6	1.874	78.3	1.746
132.5	2.791	—	—	—	—	132.4	1.777
—	—	—	—	—	—	185	1.770
—	—	—	—	—	—	200	1.740
—	—	—	—	—	—	215	1.720
—	—	—	—	—	—	232.7	$T_c$
Ethylene dibromide		Methyl isobutyrate		Ethyl alcohol		Ethyl propionate	
12.2	2.776	10	2.871	20	0.951	10	2.903
44.9	2.842	46.2	2.894	40	0.966	46.2	2.932
77.2	2.912	78.2	2.920	100	1.055	78.2	2.969
131.3	3.074	100	2.932	150	1.157	100	3.004
—	—	132.2	2.937	180	1.235	132.2	3.061
—	—	185	2.941	220	1.485	185	3.047
—	—	210	2.947	—	—	210	3.060
—	—	237.6	2.913	—	—	237.6	3.010
—	—	267.7	$T_c$	—	—	272.9	$T_c$
Propyl acetate		Methyl propionate		Propyl formate		Ethyl iodide	
10	2.917	10	2.287	10	2.270	19.1	2.034
46.2	2.954	46.2	2.302	46.2	2.278	78.2	2.044
78.2	2.966	78.2	2.329	78.2	2.331	281	$T_c$
100	2.981	132.6	2.350	85	2.334	Metaxylene	
132.6	3.010	184.9	2.365	131.7	2.356	10	3.408
185	3.011	237.7	2.278	185	2.348	—	—
210	2.999	250	1.962	210	2.339	—	—
238.2	2.980	257.4	$T_c$	237	2.312	—	—
276.2	$T_c$	—	—	264.85	$T_c$	—	—



**2. Derivation of "a" from the Surface Tension by Eötvös Law**

By the law of Eötvös the surface-tension energy  $TV_1^{2/3}$  is equal to  $C(T_c - T)$ . The surface-tension energy is a linear function of the temperature counting downward from the critical temperature. The derivation of  $TV_1^{2/3}$  and  $N^{1/3}TV_1^{2/3}$  has already been given on page 607.

a. What is C of Eötvös?

Eötvös found that C varied between 2.27 and 2.34 as is shown in Table 4, but he believed the variation to be accidental and that C should be constant for all substances. It has since been shown that C is not constant. What C is may be shown as follows:

Since the surface energy decreases uniformly with an increase of the kinetic energy of the molecules, and is accordingly a linear function of the temperature, one of the constituents of C must be the gas constant R; and since there are only  $N^{2/3}$  molecules in the surface, where N is the number in a gram mol, R must be R for a gram mol divided by  $N^{1/3}$ . The remainder of C should be  $1/3$  the ratio of the internal to the external pressure at the critical temperature as that is the point of departure. Young has shown that the surface-tension pressure is  $1/3$  the cohesive pressure; and the greater the external pressure the less important the internal pressure will be. Hence C, I thought, must equal  $K_c R / 3P_c N^{1/3}$ . While the foregoing reasoning was not entirely convincing the result turned out to be correct, I believe, as will presently be shown. I have uniformly taken N as  $6.21 \times 10^{23}$  and R as  $8.321 \times 10^7$ .

$$(8) \quad TV_1^{2/3} = K_c R (T_c - T) / 3P_c N^{1/3}$$

Since  $K_c = a/V_c^2$  we have

$$(9) \quad TV_1^{2/3} = aR(T_c - T) / 3V_c^2 P_c N^{1/3}$$

$$(10) \quad a = 3T_c V_c N^{1/3} TV_1^{2/3} / (T_c - T) S,$$

since  $RT_c/V_c P_c = S$ , and  $R = SV_c P_c / T_c$ .

Formula (10) gives the second method of computing "a."

The following values in Table 3 were computed by formula (10) from Schiff's surface-tension figures at the boiling point.  $a$  is in dynes per gram mol.

TABLE 3

Substance	S	$a \times 10^{-12}$
Methyl acetate	3.940	15.90
Propyl acetate	3.933	28.14
Diisobutyl	3.811	40.01
Benzene	3.754	20.52
Ether	3.810	19.12
Hexane	3.831	27.22
CCl <sub>4</sub>	3.676	22.60

These results are uniformly somewhat lower than those computed from Ramsay and Shields' figures by formula (7).

Returning to the value  $C$  of Eötvös formula, the following computation shows that it has in it the components ascribed to it.

It was believed, for the reasons given, that  $C$  of Eötvös must be equal to  $K_c R / 3 P_c N^{1/3}$ . The ratio of the internal to the external pressure is supposed to be, at the critical temperature, very approximately equal to 7. Its real value is as follows: If we assume that  $b_c$  of van der Waals' equation is always twice the volume at absolute zero, then  $b_c = 2V_0$ . Since  $V_0 = V_c/S$ ,  $b_c = 2V_c/S$ . If this is so then the ratio between  $K_c$  and  $P_c$  is equal to  $(S^2 - S + 2)/(S - 2)$ .  $S = RT_c/V_c P_c$ . Hence  $C$  of Eötvös must be as follows:

$$(11) \quad C = (S^2 - S + 2)R / (S - 2)3N^{1/3}$$

Formula (11) can now be tested since  $C$  is known to lie between 2.27 and 2.34 for several non-associating substances. The results of a computation of  $C$  by this formula and the values given by Eötvös are compared in Table 4.

The results are evidently closely similar, but unfortunately Eötvös did not give the value of  $C$  for many substances of which  $S$  is known.

TABLE 4

Substance	S	C computed	C found by Eötvös
Methyl acetate	3.943	2.273	—
Methyl butyrate	3.907	2.275	—
Ethyl alcohol	4.025	2.270	—
Pentane ( $n$ )	3.761	2.285	—
Ether	3.806	2.280	2.280 (6–62°); 2.26 (62–120°)
Benzene	3.794	2.279	—
Oxygen	3.40	2.355	—
Carbon dioxide	3.44	2.344	2.280
Propyl acetate	3.933	2.280	2.287
Carbon bisulfide	—	—	2.37
Chloroform	—	—	2.30
Ethylene bromide	—	—	2.27

## 2. The Computation of "a" from Thomas Young's Formula

As pointed out in an earlier paper, the first method proposed for computing the internal pressure was Young's, namely:

$$(12) \quad T = rK/3 = ra/V^23$$

$r$  being the radius of action. If  $r$  is taken at absolute zero as equal to  $v^{1/3}$  we have finally

$$(13) \quad T v_0^{2/3} = M^2 K / 3 v_0$$

$M^2 K$  is the factor "a" for a single molecule and  $v_0$  the volume of a single molecule at absolute zero. In my former paper  $v_0$  was assumed for all except the simple gases to be  $v_c/4$ , and for those gases it was taken as  $v_c/3.6$ . Timmermans<sup>1</sup> has recently confirmed S. Young's finding that the rectilinear diameter law gives too high values for the density at low temperatures and that van der Waals is correct in taking the density at absolute zero as S times the critical density, where S is the critical coefficient, or  $RT_c/V_c P_c$ , which varies with different substances between 3.4 and 4.  $T v_0^{2/3}$  I formerly computed by Ramsay and Shields' equation assuming that it

<sup>1</sup> Timmermans: Proc. Roy. Dublin Soc., [N S] 13, 310 (1912).

held at low temperatures and that  $Tv_0^{2/3}$  was equal to  $2.19(T_c - 6)/N^{2/3}$  dynes. This, however, gives values uniformly lower than method 1 and I have accordingly reverted to Eötvös original formula as already stated according to which

$$(14) \quad Tv_1^{2/3} = C(T_c - T).$$

The theoretical surface-tension energy at absolute zero should be, then,  $CT_c$  ergs for a gram mol, or  $CT_c/N^{2/3}$  ergs for a single molecule. Substituting in (13) we have

$$(15) \quad M^2KS/3v_c = CT_c/N^{2/3}.$$

Changing to the total volume  $V$ , in place of the volume of a single molecule, we have:

$$(16) \quad a = N^2M^2K = CN^{1/3}V_cT_c/S.$$

Since  $S = RT_c/P_cV_c$  by substitution in the foregoing we have:

$$(17) \quad a = CN^{1/3}P_cV_c^2/R \text{ ergs.}$$

The value of  $C$  has been given in (11). It can be found also by comparing (17) with (29) which follows. Substituting its value we have:

$$(18) \quad a = (S^2 - S + 2)P_cV_c^2/(S - 2)$$

which is identical with the formula derived from van der Waals' equation on the basis that  $b_c = 2V_c/S$ . Young's formula, then, at absolute zero yields the same result as the others when combined with Eötvös, if, however, we make no assumption as to  $C$ , but take it, as Eötvös thought it should be as constant for all substances, we obtain the approximately correct value of "a" for all except very simple substances:

$$(19) \quad a = 3 \times 2.27N^{1/3}V_cT_c/S.$$

Computations of "a" by formula 18 and 19 are given in Table 9.

We may check the foregoing reasoning in the following way avoiding any assumption of what fraction of  $V_c$   $b_c$  is. Taking Young's formula:  $T = rK/3$ ,  $r$  being equal to  $v^{1/3}$  at absolute zero, multiplying both sides by  $v_0^{2/3}$  and then by  $N$  we have:

$$(20) \quad N^{1/3}TV_0^{2/3} = V_0K_0/3.$$

Dividing by  $T_c$  and remembering that by (8)

$$N^{1/3}TV_0^{2/3}/T_c = K_cR/P_c$$

$$(21) \quad K_0V_0/3T_c = K_cR/3P_c.$$

As  $K_0 = a/V_0^2$ , and  $K_c = a/V_c^2$  and  $V_0 = V_c/S$

$$(22) \quad 1/V_0T_c = R/V_c^2P_c.$$

Therefore

$$(23) \quad S = RT_c/P_cV_c.$$

Formula 23 is true.

We may also check our reasoning as follows: From formula (6)  $a = 3MN^{1/3}TV_1^{2/3}(T_c/(T_c - T))^{2/3}/(d_1 - d_v)$  and from (8)  $3N^{1/3}TV_1^{2/3} = K_cR(T_c - T)/P_c$  we have

$$(24) \quad a = K_cRM(T_c - T)^{1/3}T_c^{2/3}/P_c(d_1 - d_v),$$

hence

$$(25) \quad d_1 - d_v = RM(T_c - T)^{1/3}T_c^{2/3}/V_c^2P_c.$$

The values of  $d_1 - d_v$  computed by (25) for ethyl acetate compare as shown in Table 5 with those found by S. Young.

TABLE 5—ETHYL ACETATE,  $d_1 - d_v$

$t$	Computed	Found by S. Young
-83.4°	1.078	1.022 (Timmermans)
0	0.9490	0.9244
100	0.8007	0.7910
200	0.5555	0.5630
240	0.3356	0.3279
249	0.2071	0.1551
249.1 ( $T_c$ )	0.0000	0.0000

At absolute zero (25) becomes  $d_0 = RMT_c/V_c^2P_c = Sd_c$  which is correct.

Substituting this value in (25) we have

$$(26) \quad d_1 - d_v = d_0((T_c - T)/T_c)^{1/3}.$$

$d_0$  computed by (26) for normal pentane using Timmerman's data for densities below zero and S. Young's above is as follows:

$t$	$d_o$	$t$	$d_o$
-136.5	0.8611	-35.3	0.8580
-123.3	0.8581	-13.1	0.8641
-116.2	0.8578	-6.2	0.8603
-111.6	0.8576	0	0.8603
-104.85	0.8570	40	0.8685
-74.25	0.8556	80	0.8776
-73.95	0.8570	100	0.8818
-63.3	0.8571	140	0.8882
-53.6	0.8566	180	0.8832
-45.0	0.8571	190	0.8762
		197	0.8443
		197.2	$T_c$

$d_o$  required by the formula:  $d_o = Sd_c$ , with Young's value of  $d_c$  is 0.8736.

The formula appears then to be correct.

By substituting in (6) the value of  $TV_1^{3/2}$  found by combining (11) and (14) there is obtained

$$(27) a = M((S^2 - S + z)/(S - z))R(T_c - T)^{1/2}T_c^{3/2}/(d_1 - d_o).$$

Table 6 contains the results of calculating "a" by this formula.

TABLE 6—"a" BY FORMULA (27) IN DYNES FOR A GRAM MOL. Oxygen (Mathias and Onnes)

Isopentane		Pentane		Oxygen (Mathias and Onnes)	
$t$	$a \times 10^{-12}$	$t$	$a \times 10^{-12}$	$t$	$a \times 10^{-12}$
-136.5	22.52	-123	23.15	-210.4	1.966
-30.6	22.63	-35.3	23.30	-182	1.956
0	22.54	0	23.03	-154.51	1.966
50	22.30	50	22.84	-140.2	1.966
100	22.00	100	22.70	Ether	
150	21.83	150	22.38	-89.2	20.53
170	22.01	180	22.48	+20	20.34
180	22.25	190	22.66	100	19.95
187	22.73	195	22.81	150	19.81
187.8	$T_c$	197	23.51	180	19.90
		197.2	$T_c$	190	19.85
				193.8	$T_c$

This formula gives remarkably constant results for the calculation clear to the critical temperature from nearly the point of solidification. The results are in agreement with other methods of calculating "a" already given or to be described. The density values for all except oxygen are those of Timmermans or Young.

### 3. Computation of "a" from van der Waals' Equation at the Critical Temperature assuming that $b_c = 2V_o = 2\bar{V}_c/S$

The values for "a" computed by the preceding methods from the surface tension agree with those computed from van der Waals' equation at the critical temperature assuming that  $b_c$ , the co-volume, or the real volume of the molecules, is always in all normal substances just twice the volume at absolute zero, or that  $b_c = 2V_o$ . As the volume at absolute zero is equal to the critical volume divided by S, where  $S = RT_c/V_cP_c$ ,  $b_c = 2V_c/S$ . Applying this to the equation, since  $V_cP_cS = RT$ , we have

$$(28) \quad a = (S^2 - S + 2)T_c^2R^2/(S^2(S - 2)P_c); \text{ or}$$

$$(29) \quad a = (S^2 - S + 2)P_cV_c^2/(S - 2).$$

Formula (28) which corresponds to van der Waals' formula:  $a = 27T_c^2/(64 \times 273^2 \times P_c)$ , has been used in computing "a" in Table 8. The values thus obtained are practically identical with those computed from the surface tension.

Formula (29) has already been obtained as (18).

### 4. The Computation of "a" from the Internal Latent Heat of Vaporization

That the foregoing values of "a" are correct is proved by their agreement with the values computed from the internal latent heat of vaporization close to the critical temperature.

If all the internal latent heat,  $\lambda$ , was used in overcoming molecular cohesion, then the equation should hold

$$(30) \quad \lambda = L - E = a(1/V_1 - 1/V_2),$$

where L is the total latent heat and E the external work. This equation does not hold except close to the critical tem-

perature, since as we go to lower temperatures "a," computed by this formula, becomes steadily larger. This is owing to the fact that some of the latent heat is consumed in doing other things than in overcoming molecular cohesion, a part probably being rendered latent by an actual expansion of the molecules.  $\mu$  is the latent heat used in increasing the intramolecular energy. It vanishes close to the critical temperatures. I have, therefore, computed "a" by this formula within a degree or so of the critical temperature. At temperatures lower than this "a" by this method will be found too large, but within a fraction of a degree of the critical temperature the change in the size of the molecules is probably negligible. To find  $\lambda$  at this temperature I have computed it from S. Young's recently published data of the liquid and vapor densities using Mills' formula for the computation of  $\lambda$ , namely,

TABLE 7—COMPUTATION OF "a" FOR ONE GRAM MOL FROM INTERNAL HEAT (NEGLECTING  $\mu$ )

Substance	Distance from the critical temperature	$a \times 10^{-13}$
Pentane (n)	—0.05°	2.108
Pentane (iso)	—0.4	2.065
Hexane	—0.8	2.814
Heptane	—3.5	3.616
Octane (n)	—6.2	4.575
Hexamethylene	—1.0	2.445
Ether	—0.8	1.945
Carbon tetrachloride	—3.15	2.202
Benzene	—0.15	2.112
Fluorbenzene	—6.55	2.266
Chlorbenzene	—89.2	3.260
Methyl formate	—0.5	1.145
Methyl acetate	—0.7	1.772
Methyl propionate	—1.4	2.349
Ethyl acetate	—1.0	2.359
Propyl formate	—4.85	2.395
Ethyl propionate	—2.9	3.058
Methyl butyrate	—1.3	2.989
Methyl isobutyrate	—1.05	2.892

<sup>1</sup> Mills: Phil. Mag., 21, 85 (1911).



$\lambda = C(d_1^{1/3} - D_v^{1/3})$ . The value of C was the mean C taken from Mills' recent paper. These values of the internal latent heat are very similar to those obtained by Dieterici's formula  $\lambda = CRT\ln d/D$ . If the internal latent heat is computed using the vapor pressures computed by Biot's formula close to the critical temperature too low values are obtained as Mills has pointed out.

The values for "a" for one gram mol computed from near the critical temperature are given in Table 7. Column 2 of that table shows how many degrees below the critical temperature data were taken for the computation. The nearer the critical temperature the more reliable the data should be.

$$(31) \quad a = M(\lambda - \mu)/(d_1 - d_v).$$

It is interesting now to see how large  $\mu$  is relative to  $\lambda$  at different temperatures; that is, how much of the heat of vaporization is rendered latent by the expansion of the molecules, or by an increase in their rotatory energy. By formula (31)  $a = M(\lambda - \mu)/(d_1 - d_v)$ ; and by (29)  $a = (S^2 - S + 2)P_c V_c^2 / (S - 2)$ . Hence we have

$$(32) \quad \lambda - \mu = (S^2 - S + 2)P_c V_c^2 (d_1 - d_v) / M(S - 2).$$

But it was found by Mills that  $\lambda = C(d_1^{1/3} - d_v^{1/3})$  so that

$$(33) \quad \mu = C(d_1^{1/3} - d_v^{1/3}) - (S^2 - S + 2)P_c V_c^2 (d_1 - d_v) / M(S - 2).$$

The calculation of  $\mu$  for one gram mol of pentane by formula (33) resulted as follows:

$t$	$\mu \times 10^{-10}$ ergs
-273°	4.25
+ 30	4.46
60	3.51
100	2.18
150	0.62
190	-0.0026
197.2	$T_c$

At 30°, therefore, the total latent heat for one gram is 85.76 cal.; the total internal latent heat, or  $\lambda$ , is 78.80 cal.;

TABLE 8— $a \times 10^{-12}$  FOR ONE GRAM MOL IN DYNES

<sup>1</sup> Substance	<sup>2</sup> $a = 3MN^{1/2}TV^{1/2}(T_c - T)/T_c(d_1 - d_2)$	<sup>3</sup> $a = 5.835 \times 10^8 T_c V^2/S$	<sup>4</sup> $a = (S^2 - S + 2)T_c^2 R^2 / (S^2(S - 2)P_c)$	<sup>5</sup> $a = M(\lambda - \mu) / (d_1 - d_2)$	<sup>6</sup> $a = 1.259 \times 10^{11} (M \times Val)^{1/2}$	<sup>7</sup> Valency
Oxygen	> 1.700(?)	1.966	2.002	—	2.014	O = 1
Hydrogen (S = 3.4)	—	0.306	0.317	—	0.317	N = 1
Nitrogen	—	1.796	1.836	—	1.842	N = 1; O = 4
Nitrous oxide	—	5.070	5.249	—	5.180	
Pentane (n)	—	22.52	22.43	21.08	21.96	
Pentane (iso)	—	22.07	22.17	20.65	21.96	
Hexane	—	—	—	28.14	27.71	

TABLE 8—(Continued)

Heptane	—	34.82	34.82	<36.16	33.80	
Octane	44.72	42.00	41.98	<45.75	40.17	
Ether	20.33	20.13	20.21	19.45	20.46	Cl = 3
Carbon tetrachloride	24.01	24.28	24.53	<22.02	22.94	
Benzene	22.33	22.32	22.41	21.12	22.19	
Chlorobenzene	29.73	30.00	30.09	<32.60	29.95	Cl = 3
Toluene	28.12(?)	—	—	—	27.97	
Metaxylene	34.08	—	—	—	34.06	
Anisol	34.66	—	—	—	32.26	
Cymene	49.82(?)	—	—	—	47.09	
Chloroform	18.57	—	—	—	18.00	Cl = 3
Methyl formate	12.24	12.45	12.44	11.45	12.25	
Methyl acetate	17.43	17.03	17.01	17.72	17.42	
Methyl propionate	22.83	22.15	22.16	<23.49	22.96	
Ethyl acetate	23.61	22.08	22.07	<23.59	22.96	
Propyl formate	23.21	23.05	23.05	<23.95	22.96	
Methyl butyrate	30.00	28.08	28.06	<29.89	28.84	
Methyl isobutyrate	28.94	27.55	27.60	<28.92	28.84	
Propyl acetate	29.78	28.05	28.03	—	28.84	
Ethyl propionate	29.98	27.89	27.87	<30.58	28.84	Br = 3
Ethylene dibromide	29.01(?)	—	—	—	28.36	
Piperidine	26.91(?)	—	—	—	25.54	
Carbon bisulfide	13.38	—	—	—	14.34	S = 6
Ethyl alcohol	12.53(?)	12.44	12.44	—	10.26	
Stannic chloride	—	32.43	32.58	—	32.58	Cl = 3

<sup>1</sup> The figures of column 2 are the average values of Table 2, omitting divergent values close to critical temperatures.

TABLE 9— $c \times 10^{-12}$  COMPUTED BY VARIOUS FORMULAS

	1	2	3	4	5	6	7	8	9	10
		$a = 3TV_2^{1/2}N_1^{1/2}M(T/L)^{1/2}(d_1 - d_2)$	$a = 3TV_2^{1/2}N_1^{1/2}M(T/L)^{1/2}(d_1 - d_2)$	$a = 3TV_2^{1/2}N_1^{1/2}N_2^{1/2}V_2(T - T_c)$	$a = ((S^2 - S + 2)/S - 2)P_2V_2^2$	$a = M((S^2 - S + 2)/S - 2)R(T_c - T)^{1/2}T_c^{3/2}/(d_1 - d_2)$	$a = ((S^2 - S + 2)/S - 2)T_c^2R_2/S^2P_2$	$a = 5.835 \times 10^3 T_c^2 V_2 / S$ (Approximate)	$a = M(\lambda - \mu)/(d_1 - d_2)$	$a = 1.259 \times 10^{11} (M \times V_2)^{1/2}$
Oxygen		> 1.700	—	—	2.002	1.966 (-210.4°)	2.002	1.800	—	2.014
Pentane ( $\eta$ )		—	—	—	22.43	22.70 (100°)	22.43	22.13	21.08	21.96

TABLE 9—(Continued)

Hexane	28.59 (8.2°)	27.72 (68.1°)	27.32	28.33	28.96	28.33	28.38	28.14	27.71
Octane	44.72	41.86 (15.5°)	40.01 (Diisobutyl)	41.98	—	41.98	42.10	<45.75	40.17
CCl <sub>4</sub>	24.01	22.63 (75.2°)	22.60 (75.2°)	24.53	24.54 (20°)	24.53	24.34	<22.02	22.94
Ether	20.33	20.34 (20°)	19.12	20.21	20.34 (20°)	20.21	20.17	19.45	20.46
Methyl acetate	17.43	—	15.90	17.01	17.55 (10°)	17.01	17.06	17.72	17.42

and  $\mu$ , the heat rendered latent by an increase in the intramolecular energy, is 14.80 cal. While the figure 14.80 is undoubtedly a little too low it appears that approximately one-fifth of the total internal latent heat goes within the molecules at the fraction  $0.313T_c$ . Furthermore, the internal intramolecular latent heat does not increase much, if at all, at temperatures lower than this. The theoretical latent heat at absolute zero was calculated by Mills' formula, and  $d_0$  was taken as  $Sd_c$ .

### 5. Computation of "a" from the Number of Valences and Molecular Weight

Finally I have calculated "a" for a gram mol by the formula:<sup>1</sup>

$$(34) \quad a = C(M \times \text{Val})^{2/3}$$

C is taken arbitrarily as equal to  $1.259 \times 10^{11}$ . M is the molecular weight, and Val the numbers of valences per molecule.

The values computed in these different ways are given in Table 8. For the surface tension computations I have taken the data from Ramsay and Shields, Ramsay and Ashton and Renard and Guye. In all cases when computing "a" by the last formula the valence of carbon has been taken as 4; oxygen as 2, except in oxygen gas, where it is unity; nitrogen as 3, except in nitrogen gas which has been taken as monovalent; and hydrogen as 1. The critical data of oxygen are accurately determined; for hydrogen, the critical density being uncertain, I have assumed S to be 3.4, the same as oxygen; in computing nitrogen, the critical density being uncertain, I took S as 3.5 and the density 0.33, which is between the values given by Sarrau and Hautefeuille and Cailletet. For all substances included in his list Young's critical data have been used. The critical temperatures and pressures of the other substances have been taken from the Landolt-Meyerhoffer tables. Where the critical density was unknown I have been unable to compute by formulas which involve that factor. In other cases the surface-tension data or the vapor densities could not be found. Hence there are many gaps in the table.

<sup>1</sup> Mathews: Jour. Phys. Chem., 17, 181 (1913).

It will be seen by an inspection of Tables 8 and 9 that all the formulas, *i. e.*, those from the latent heat; from van der Waals' equation, assuming that  $b_c$  is  $2V_c/S$ ; from the surface tension; from Young's formula and that involving the molecular weight and number of valences, give practically the same result. The confirmation of the values from the surface tension and van der Waals' equation by the computation from the latent heat close to the critical temperature is, I think, conclusive evidence that these results are correct, within the limits of error of the data from which they are computed. The internal pressures of such liquids as benzene and ether are, therefore, about 14 per cent. higher than have been calculated by van der Waals' formula:  $a = 27T_c^2/64 \times 273^2P_c$ . As a result the co-volume, or the volume of the molecules, the value "b," must be taken larger both in the liquid and vapor than has been customary.

The values for "a" and  $M^2K$  given in my earlier papers should be multiplied by 1.085 approximately to bring them to these new and correct values.

The internal pressures at zero degrees centigrade computed by Lewis, by the method of van der Waals and by formula (7) compare as follows (Table 10):

TABLE 10—INTERNAL PRESSURES IN ATMOSPHERES AT ZERO DEGREES

	Lewis	v. d. Waals	Formula (7) Surface tension
Ethyl acetate	2466	2261	2507
Ether	1932	1723	1986
Carbon tetrachloride	2518	2205	2637
Carbon bisulfide	2917	3363	3937
Benzene	2639	2494	2946
Toluene	2847	2228	2534
<i>m</i> -Xylene	2815	2068 (10°)	2286 (10°)

The values obtained from the surface tension and from the latent heat of expansion as computed by Lewis, agree pretty well except in the case of carbon bisulphide; they are widely

different from those computed by Walden from Stefan's conclusion, Walden's values being in fact about two-thirds of my values. The figures given for the internal pressures of liquids by Walden, Davies, and Traube are certainly far too low and are erroneous.

#### Summary

The internal pressures of liquids, or rather the value "a" of van der Waals' equation, has been computed from the surface tension, assuming that the depth of the surface layer is  $(T_c/T_c - T)^{2/3}$  molecular diameters; from the law of Eötvös and T. Young; from van der Waals' equation, assuming that  $b_c$  is always  $2V_c/S$ , S being equal to  $RT_c/V_cP_c$ ; from the internal latent heat of vaporization close to the critical temperature, and from the molecular weight and the number of valences. All of these methods give practically the same results. The values of "a" thus computed are constant in the case of pentane and ether over a wide range of temperature, indicating that barring association "a" is constant; the values are uniformly higher than those computed by others with the exception of some computed recently by Lewis from the latent heat of expansion of liquids. The values recently given by Traube, Walden and Davies are too low and incorrect in other ways. The results confirm my conclusion that the molecular cohesion is a function of the molecular weight and the number of valences in the molecule. The formula:  $a = 27T_c^2/64 \times 273^3P_c$  gives values about 14 per cent. too low for ordinary substances and very much too low for simple diatomic gases. It should be replaced by the formula  $a = (S^2 - S + 2)T_c^2R^2/(S^2(S - 2)P_c)$ . These results show, also, that Stefan's conclusion that half the work in vaporization is done in moving a particle into the surface is incorrect.<sup>1</sup>

*University of Chicago*

<sup>1</sup> APPENDIX.—By combining (23) and (26) we have the following formulas for calculating S and  $d_c$ . M is the molecular weight:

$$(35) \quad S^2 = (d_e - d_v)T_c^{4/3}/(T_c - T)^{1/3}MP_c$$

$$(36) \quad d_c^2 = MP_c(d_e - d_v)/RT_c^{2/3}(T_c - T)^{1/3}$$



## THE FILTRATION OF BARIUM SULPHATE

BY J. L. OSBORNE

Krak<sup>1</sup> has recently stated that to filter barium with suction seems a rather daring experiment even when specially prepared filters are used, but that it may be done as follows:

"Pour the supernatant liquid through the filter using suction. Before the precipitate begins to follow, add about 10 cc of a saturated, slightly acid, solution of ammonium acetate to the precipitate and stir it up well. The fine BaSO<sub>4</sub> changes instantly into a coarse precipitate and can be washed instantly while suction is going full speed without ever passing through the filter. The results thus obtained are not influenced by the use of the filter solution."

This sounded as though the barium sulphate were coagulated by the ammonium acetate solution. It seemed desirable to verify this and to see what would be the effect of adding solid ammonium acetate to a solution from which barium sulphate had been precipitated cold. A number of experiments were therefore made to determine what happens and what are the limitations of the method, if any.

Equivalent solutions of barium chloride and of sulphuric acid were prepared and 100 cc of the barium chloride solution were added a little at a time to 100 cc sulphuric acid, stirring continuously and keeping the solutions at 75°-80°. The precipitate is coarse enough for ordinary filtration by gravity but is sucked through a filter paper when suction is applied. In the next experiment the supernatant liquor was decanted, as recommended by Krak, and 10 cc saturated ammonium acetate solution were stirred up with the residue. There seems to be a solution of the barium sulphate which reprecipitates as coarser crystals which are not carried through a filter paper by suction. There is no difficulty at all in duplicating Krak's result.

<sup>1</sup> Chemist Analyst, 1912, 26.

In another experiment the barium sulphate was precipitated hot as before but the supernatant liquid was not decanted. About 75 grams of solid ammonium acetate were added to the solution, making the concentration with respect to this salt practically the same as in the preceding experiment. Filtration by suction was not possible. The whole mixture was boiled for 9-10 hours, but even then the barium sulphate ran through the filter under suction. This showed that a mixture of ammonium acetate and hydrochloric acid behaves quite differently from ammonium acetate alone. This might be due to the free acid or to the chloride preventing the growth of the crystals, or it might be that the chloride had a peptonizing action and disintegrated the barium sulphate.

A hot solution of ammonium sulphate was precipitated by adding just sufficient hot barium chloride solution. Since there were about 110 cc of solution, approximately 100 grams of solid ammonium acetate was added and the mixture was boiled for 8 hours, 4 hours at a time with several hours of standing between the two periods. The barium sulphate could then be filtered with suction. This experiment shows that ammonium chloride retards but does not prevent the growth of the barium sulphate crystals.

Some barium sulphate was made filterable by Krak's method. This was boiled for 9 hours with an ammonium chloride solution. At the end of this time the crystals filtered as well as before, thus showing that the ammonium chloride solution had no peptonizing or disintegrating action.

To determine whether Krak's method worked well with neutral and acid solutions, three sulphate solutions were made up of the same strength, sodium sulphate, sodium sulphate acidified with hydrochloric acid, ammonium sulphate. These solutions were heated to 80° and sufficient hot barium chloride solution added to ensure complete precipitation. The mixtures were brought to boiling for 5 minutes and were then allowed to stand over night. In each case the supernatant liquid was decanted, 5 cc of saturated ammonium acetate

added, and the solution boiled for 5 minutes. The precipitates did not filter well, so 10 cc more of ammonium acetate solution were added to each beaker. Each solution was boiled for 1 minute and then allowed to stand. There was no difficulty in filtering with suction, the three lots behaving practically alike.

The last experiments dealt with cold precipitation of sulphuric acid by barium chloride. After decantation, ammonium acetate solution was added and boiling was kept up for 8-10 hours. It was quite impossible to filter the barium sulphate. The experiment was repeated with 20 cc ammonium acetate solution, boiling steadily for 96 hours, using a reflux cooler. At the end of this time the barium sulphate filtered nicely with full suction.

These experiments clear up the theory of the process. Barium sulphate is soluble in ammonium acetate solution and the crystals therefore grow in a hot solution. If the barium sulphate is precipitated under conditions such that the crystals are nearly large enough to permit of filtration with suction, a short heating is enough to make them grow to the required size. If the barium sulphate is precipitated cold, the crystals are small and a very much longer heating is necessary to give the required size. Since ammonium chloride and hydrochloric acid do not peptonize or disintegrate the barium sulphate crystals and yet do retard the growth, it is clear that these substances decrease the solubility of barium sulphate in ammonium acetate solutions.

This work was suggested by Professor Bancroft and has been carried on under his supervision.

*Cornell University*

## NEW BOOKS

**Methods in Chemical Analysis.** By Frank Austin Gooch. 15 × 23 cm; pp. xii + 536. New York: Wiley and Sons, 1912. Price: \$4.00.—Methods of analysis in analytical work have become so well known to the chemist in quantitative fields from the old and familiar works of Olsen, Treadwell, Fresenius, Sutton and others, that this new book called "Methods in Chemical Analysis" by Prof. F. A. Gooch, of the Kent Laboratory of Yale University, may offer quite a surprise to all who may have occasion to use it. The older books mentioned are undoubtedly text books but Prof. Gooch's book contains rather too many experimental results to be ordinarily used as a text book. In fact, it impressed the reviewer as being a bound volume of the writer's research notes, and in a way that is what it really is. In his prefatory note the writer has explained his purpose thus:

"The object of this volume is to present concisely the principal results reached by the workers in the Kent Chemical Laboratory of Yale University in the investigation and development of methods in chemical analysis. In the account of processes, modified or original, only proved procedure, and immediately related experimental data are, as a rule, given. For further details in the elaboration of processes, the discussion of difficulties, and the experimental illustration of the effects of varying the prescribed procedure, references are given to the original sources from which this summary has been compiled." From this viewpoint it may be stated that it is a very interesting, and in many ways, valuable volume. While the subject is not taken up from the standpoint of the familiar texts mentioned above, the book contains methods in the analysis of the more unusual elements and compounds that cannot be found outside of the literature. In this regard the book is very interesting as well as quite complete.

The first chapter is called "Appliances and General Procedure" and takes up processes and methods, old and new, in use in quantitative and research work. It contains many new ideas. Some of the descriptions are of home-made apparatus when commercial apparatus is obtainable which is more convenient to use. For instance, on page 12 is shown an electrolysis board, using a small motor with rubber stopper, over which is pressed a platinum crucible, for cathode. In this arrangement there is no controlling resistance for the speed of the motor, one side of the cell is grounded and the contact to the crucible is uncertain and inconvenient. The complete boards on the market are much more compact and handy. It is often an advantage, too, to use a wire gauze cathode and this would be hard to attach and detach.

Chapter II deals with the "Alkali Metals" and has some original methods for the detection of sodium, the separation and determination of both sodium and potassium as the pyrosulphate and perchlorate. Chapter III, "Copper, Silver and Gold," contains some newly revised gravimetric methods for copper as well as the details for the electrolytic methods for copper as well as the details for the electrolytic separation. A method is shown for the separation of copper, as the sulphocyanate, from bismuth, arsenic, tin and antimony that may be found quite convenient because of the failure of the electrolytic process in the presence of the four metals mentioned. The usual objection to the determination of

silver as the chloride is removed here by using silver chromate as the final compound. Also interesting and modern is the colorimetric determination of gold. Many new and very successful methods are found in Chapter IV, "Beryllium, Magnesium, Calcium, Strontium, Barium," that are not taken up in the more familiar texts. Chapter V takes up "Zinc, Cadmium, Mercury," and Chapter VI, "Boron, Aluminum, Lanthanum, Thallium." While the determination of some of the members of the third group is by no means common, yet reliable methods for their separation and quantitative values are most welcome.

Chapter VII takes up "Carbon, Silicon, Titanium, Zirconium, Cerium, Tin and Lead," giving both old and some new methods for these elements. Titanic acid is reduced by zinc and then titrated with permanganate. Chapter VIII contains a large number of methods for "Nitrogen, Phosphorus, Arsenic, Antimony, Bismuth and Vanadium." The sixth group is taken up in Chapter IX, "Oxygen, Sulphur, Selenium, Tellurium." Chapter X, "Chromium, Molybdenum, Uranium." Chapter XI deals with methods for the halogens "Fluorine, Chlorine, Bromine, Iodine." The last chapter is called, "Manganese, Nickel, Cobalt and Iron." There are several good electrolytic methods given throughout the work. The very accurate and fast method for nickel as the diglyoxime is not given and when recalling several important omissions, one must remember that the work is not intended as a complete one but rather to set forth the methods worked out and checked in the Kent Laboratory.

As the writer has mentioned, the book is well supplemented by the directly related experimental data. This serves to show the limits of the determination, it is true, but these tables take up a larger share of the book than corresponds to their importance. In its completeness it is good, as the more common methods are already well represented in our standard reference books and texts, and do not demand a place in a work of this nature. Frequent and full reference is given to the original sources in the literature of almost all the articles and it may be stated that "Methods in Chemical Analysis" will be a valuable book to the commercial analyst, the research man, and the advanced student.

Charles O. Brown

**Concentrating Ores by Flotation.** By Theodore J. Hoover. 24 × 16 cm; pp. 221. London: *The Mining Magazine*, 1912. Price: 12s., 6d.—One of the important developments of recent years in the mining industry has been the concentration of ores by selective flotation. "This book is intended as an interim report of progress in a rapidly developing art. It is put forward in the hope that it may prevent duplication of labor on the part of ambitious inventors, and that it may give engineers not already familiar with the subject a starting point in the application of a new method of turning ores into account."

The subject has been treated under the headings: historical sketch; patents; litigation; theories; tests; the Potter-Delprat process; the De Bavay process; the Elmore Vacuum Flotation Process; the Minerals Separation Process; other flotation processes; economics; bibliography.

The flotation processes are based on the experimental fact that certain substances will adsorb oil and air more readily under certain conditions than do other substances, and consequently will float on water, while the other substances

sink. More particularly, zinc and other sulphides float while the siliceous gangues sink.

"The development of this important department of metallurgy can be divided roughly into three stages. During the first of these, 1860 to 1902, there were brought forward at least a dozen methods for causing sulphides to float on an ore-pulp, and these methods fell into two principal classes, although there were even then some patents which could not properly be placed in either class.

"(1) Those depending on the selective action of oily substances for sulphide particles to entrap the sulphides, and the buoyancy of the oily substance to effect flotation.

"(2) Those depending on the selective action of gas for sulphide particles, and which under certain conditions endowed the particles with a gaseous envelope, and so induced flotation.

"Neither of these ideas when used independently produced entirely satisfactory results, although they were not without some commercial profit.

"The second stage, from 1902 to 1907, was marked by a practical advance when the idea was developed of endowing the particles with an oily coating in an acid solution, thus increasing their affinity for the gaseous envelope. This combination of the two fundamental ideas of the preliminary stage has made it possible to secure a high degree of flotation among many sulphides. These two stages belong primarily to the inventor, the so-called impractical man.

"The third stage, 1907 to 1912, in which we now are, is the stage of the engineer: the commercial application of the idea. Suitable mechanical devices had to be invented to produce the proper mixture of gases, liquids, and solids, and to entrap the concentrate when afloat. This stage has now reached so practical a development as to find widespread commercial application."

The author's version of the theory is given on p. 53. "With some substances the gas adhesion is strong and the liquid adhesion is weak: in other words, they are wetted with difficulty. In this class are the metallic sulphides, which, although they have a natural tendency not to adhere strongly to water, do fortunately have a strong natural tendency to adhere to oil. And further, oil has an even stronger tendency to adhere to its gas film, so that a sulphide particle covered with an oil film has an already strong tendency not to adhere to water considerably increased. Quartz and gangue minerals generally, on the other hand, have preference in directly the opposite direction. They have a comparatively feeble adhesiveness to gas films and oil, and a strong adhesiveness to water, and this already strong adhesiveness for water is greatly increased by a slight acidulation of the water. There has been no satisfactory theory yet propounded as to why acid does promote the preferential adhesion of water to gangue particles, and probably also at the same time the preferential adhesion of oil to sulphides, and for the present commercial purpose it does not seem necessary to do more than record this important fact."

On p. 59 the author says that "it is a significant fact that no method has yet been found of producing a mineral froth by air bubbles without the addition of oil or some other substance. Among other substances that will assist in producing a commercially effective mineral froth are a number of soluble substances,

as amyl alcohol, camphor, most of the essential oils, the phenols, and a number of gas-tar derivatives.

"The phenomena to be observed in connection with the use of these soluble substances as mineral frothing agents are confusing. What has been said about the oil adhering to the sulphides in the first part of this chapter does not apply in the case of these substances, because they are completely soluble in the proportions used, the small amount employed in treating the (1 lb. per ton of ore) cannot be thought to adhere preferentially to the sulphides. On the other hand, although these substances are soluble, the solution cannot be used over and over again beyond certain narrow limits, but the frothing agent must be added continuously. It is also inconceivable that there is any chemical reaction between, say, the soluble essential oil of *eucalyptus amygdalena* and any of the ingredients of the ore. The froth produced in this case had identically the same appearance as where air, oil, and acid, or acid and carbon dioxide, are the froth constituents, and we are justified in assuming that in the main there is no difference in the forces acting."

This book can be obtained in the United States from the Mining and Scientific Press, 420 Market Street, San Francisco, for \$3.75 net.

Wilder D. Bancroft

*Beiträge zur Kenntnis des elektrochemischen Verhaltens des Eisens.* By F. Foerster. 17 × 24 cm; pp. 83. Halle: Wilhelm Knapp, 1909. Price: paper, 3.20 marks.—Through an unfortunate oversight, this book was not reviewed at the time that it appeared. Since the book is just as valuable now as formerly, a belated notice seems better than none.

The true single potential of iron is found to be about  $E_h = -0.46$  volt, in close agreement with the results of Richards and Behr. Displacement towards the zinc potential is due to hydrogen in the iron. A sample of such iron gives off hydrogen when allowed to stand in contact with a ferrous sulphate solution from which air is excluded. More noble potentials are due to the presence of oxide films. The decomposition potential of iron is the same as the single potential at equilibrium; but there are distinct variations in the voltage at which iron ordinarily precipitates. Part of this is due to the presence of ferric salts in solution; but part of it is due to the electrode, presumably to the taking up of hydrogen.

Since the peeling of electrolytic iron is due in part to the variations in the hydrogen content, a more satisfactory deposit can be obtained at higher temperatures. For the same solution and the same current density, iron is more coarsely crystalline, the higher the temperature of deposition. The author leaves it open, p. 75, whether there are several modifications of electrolytic iron. It seems to the reviewer that the differences observed are chiefly differences in crystal size due to changes in current density.

Wilder D. Bancroft

*Physico-Chemical Tables.* By John Castell-Evans. Vol. 2. 18 × 25 cm; pp. xiv + 585. Philadelphia: J. B. Lippincott Co., 1911. Price: \$12.00.—"With the present volume of Physico-Chemical Tables which contains the concluding portions of the Tables of Physical Chemistry, the commencement of which will be found in Volume I, together with a valuable and exhaustive series

of tables specially applicable to the operations of analytical chemistry, the work of the late John Castell-Evans is brought to a close."

The data for physics in this volume are tabulated under the general heads: molecular dynamics, kinetic theory of gases, etc.; molecular speeds, molecular volumes, etc., of liquids; influence of temperature on surface tension, etc.; capillarity constants of solutions; cryoscopic method; vapor-tension method; distillation of mixed liquids. There are also 180 pages of tables containing data useful in analytical chemistry. A book like this represents an incredible amount of labor and it is fortunate that there are men who are willing to undertake such a task.

Wilder D. Bancroft

*Introduction a l'Etude de la Spectrochimie.* By G. Urbain. Paris: A. Hermann et Fils, 1911. Price: 10 francs.—The subject is treated under the headings: generalities on light and spectra; emission under the influence of heat (flame spectra); luminescence of gases under diminished pressure (Geissler tubes); arc and spark; phosphorescence; absorption; constitution of spectra. The author says, p. 17, that "it is time that spectrum analysis should take the place in chemical laboratories which it deserves. The best means of accomplishing this is to teach the subject more thoroughly. At present young chemists have an incomplete or even incorrect conception of the part which the spectroscopy may play in analytical chemistry." Attention is also called, p. 19, to the fact that the flame spectrum is not necessarily an extraordinarily sensitive test and that the sensitiveness can be cut down almost at will by taking the weaker lines instead of the strongest ones.

In various places, pp. 67, 88, the author raises the question whether the spectra are temperature functions or are due to chemical reactions. Unfortunately he is apparently afraid to commit himself and consequently leaves the matter open, though an estimated minimum temperature of 30,000° in a Geissler tube does not seem probable. One of the specially interesting facts is that the phosphorus spectrum, p. 71, is greener in a cold flame than in a hot one. Except on the basis of a chemical reaction, it seems difficult to account for the results, p. 92, of Ramsay and Collie on the behavior of a mixture of hydrogen and helium under varying pressures.

Though reference is made, p. 137, to the work of de Gramont, it seems to the reviewer that the treatment here is so brief that the student will fail completely to appreciate the importance of this work.

Wilder D. Bancroft



## LUMINESCENCE

BY E. F. FARNAU

### Introductory

The term luminescence is generally applied to that property possessed by a large number of substances of becoming luminous under the influence of light or other forms of radiation. When produced by light, the phenomenon is accompanied by absorption of the incident light of certain wave-lengths, the luminescence consisting of light of wave-lengths differing from those of the exciting light. Various classifications have been made, depending upon the conditions under which the phenomena take place. If the luminescence occurs only so long as the exciting light falls upon the substance, it is called fluorescence; if it persists after excitation is discontinued it is called phosphorescence. Often after the phosphorescence has decayed at ordinary temperatures until it has become invisible, it can be revived for a time by heating the substance—this is known as thermoluminescence. Production of light by fracture of crystals is called triboluminescence, by cathode rays cathodoluminescence, by solidification of a melt or precipitation from solution crystalloluminescence. In many of these cases the luminescence occurs with almost imperceptible rise of temperature; and for this reason has been termed "cold light." Many chemical reactions occur, often at low temperatures, with evolution of light, this is called chemiluminescence. There are more or less permanent changes in the chemical properties of substances made luminescent—some showing but transitory changes, while in others visible chemical decomposition occurs. It is the purpose of this research to determine the course of the chemical reaction taking place and to correlate the different kinds of luminescence under one substantially confirmed hypothesis.

### Luminescence by Cathode Rays

Wiedemann and Schmidt<sup>1</sup> were the first to make a

<sup>1</sup> Wied. Ann., 54, 622 (1895); 56, 203 (1895); 64, 78 (1898).



systematic study of this kind of luminescence. They observed that in many cases at least, decomposition occurred, and decided that the luminescence was due to recombination of these decomposition products to form the original salts. Furthermore, it was claimed that the color of the emitted light depended solely upon the metal, citing the case of cadmium and uranium salts.

Goldstein<sup>1</sup> observed that in the action of cathode rays upon alkaline halides the color change produced by the rays was but temporary, heat or moist air restoring the salts to their original condition. The color change was accounted merely a physical change.

Wilkinson<sup>2</sup> substantiated the hypothesis of Wiedemann and Schmidt by comparison of the light emitted during the reaction of the probable decomposition products of the salts with the cathodoluminescence of the salts themselves. This paper will be discussed under the section "Luminescence by Chemical Reaction."

Owing to the uncertainty in dependence upon another's description of color as well as to possible variations in quality of the luminescence due to impurities in the salts employed, Wilkinson's experiments were repeated. A few cases of disagreement were observed, as is evident from Table I, but these alterations merely confirm the hypothesis.

The apparatus employed for production of cathodoluminescence consisted of a cathode tube seven inches long, one and one-half inches in diameter, in two parts—an upper carrying the disc cathode and ring anode, and a lower containing the salt. The vacuum was produced by a Geryk double cylinder oil pump making about thirty strokes per minute, run by a  $\frac{1}{6}$  H. P. induction motor hitched up to the wheel of the pump through an intermediate reducing pulley. A large induction coil, working at a mean current of 5 amperes and a mean voltage of 60 volts in the primary, and whose secondary furnished under these conditions a four-inch spark,

<sup>1</sup> Wied. Ann., 54, 371 (1894).

<sup>2</sup> Jour. Phys. Chem., 13, 691 (1909).

was used to operate the cathode tube. The pump was worked continuously during excitation.

TABLE I

Salt	Fluorescence W	Fluorescence F	Color of residue W	Color of residue F
NaCl	whitish	bluish white	brown	brown
NaBr	blue-white	bluish	rose	brown
NaI	white	greenish	brown	brown
KCl	white	bluish white	dark violet	dark violet
KBr	green	blue	blue	blue
KI	green	green	brown	brown
Hg <sub>2</sub> Cl <sub>2</sub>	orange	orange	black	black
Hg <sub>2</sub> Br <sub>2</sub>	orange	orange	brown	brown
HgCl <sub>2</sub>	greenish	greenish	brown	brown
HgBr <sub>2</sub>	orange	greenish	brown	brown
CdCl <sub>2</sub>	—	green-blue	—	brown
CdBr <sub>2</sub>	yellow-white	green-blue	—	brown
CdI <sub>2</sub>	white	yellow	—	brown
CdSO <sub>4</sub>	yellow	yellow	brown	brown

If cathodoluminescence is caused by a chemical reaction, rise of temperature should increase the luminescence for the same amount of decomposition because the reaction velocity would increase. The following experiments were carried out to illustrate this point: A sample of cadmium sulphate from Eimer & Amend, showing but slight luminescence,<sup>1</sup> was heated to dull redness in platinum to remove moisture, and, after powdering, was heated in the cathode tube. The results were unsatisfactory, the vacuum dropping off markedly and hence reducing the amount of effective radiation. This is doubtless due either to a slow evolution of adsorbed gases and moisture at the higher temperature, or to increased permeability of the glass to air. To obviate this difficulty, cooling the salt instead of heating was employed. All of the tube save about one-half an inch of the bottom part was wrapped loosely with cotton gauze and jacketed. The slightly luminescent

<sup>1</sup> Wilkinson: Jour. Phys. Chem., 13, 720 (1909).

pure salt was replaced by a commercial sample, fairly strongly luminescent. Liquid air was dropped upon the gauze until the luminescence reached a maximum indicating attainment of the best possible vacuum. The bottom of the tube was then immersed in liquid air in order to cool the salt; the fluorescence almost entirely disappeared. Lowering the temperature of the salt had decreased its luminescence by decreasing the rate of combination of its decomposition products, in confirmation of the theory.

Discoloration of the salts in all the cases observed causes marked falling off of the fluorescence. It was especially observed with cadmium iodide. This salt is discolored rapidly under cathode rays, probably with separation of cadmium and iodine, the emitted light at the same time becoming extremely faint. If the tube is shaken, exposing fresh surfaces of the crystals, the fluorescence flashes up momentarily, and then diminishes rapidly. The same difference in light intensity is observed with pure white crystals of cadmium bromide and with the same salt slightly discolored by fusion in platinum. The effect is doubtless largely due both to decrease in the reflecting power of the salt and to absorption of the cathode rays (which actually possess but slight penetrating power) by the discoloring substance instead of by the salt itself. This latter explanation is borne out in experiments with the iron arc in which this rapid decrease of luminescence with increasing discoloration of the salt is not observed, the ultraviolet light penetrating more deeply than do the cathode rays.

The effect of addition of traces of other salts on the luminescence of cadmium sulphate has been investigated. Wilkinson<sup>1</sup> had found that small amounts of sodium, potassium, lithium, or zinc sulphate caused the excited salt to show luminescence. Some of the results of Waggoner<sup>2</sup> are at variance with these conclusions. Table II is from the latter paper. It will be noted that in many cases metathetical reactions with or without the formation of a pre-

<sup>1</sup> Jour. Phys. Chem., 13, 719 (1909).

<sup>2</sup> Phys. Rev., 31, 358 (1910).

precipitate will occur, and the resulting substance will not be homogeneous in these cases. Waggoner is not specific in describing his method of preparation of these specimens and it would be difficult to decide from his results as to just what chemical compound or solid solution the luminescence is due. The experiments could be checked by comparing the luminescence of each of the products of metathesis with that of the mixture.

TABLE II

Na salt added	Phosphorescence	Na salt added	Phosphorescence
SO <sub>4</sub>	yellow	SiO <sub>4</sub> , Br	blue
S <sub>2</sub> O <sub>3</sub> , OH, CO <sub>3</sub> , CrO <sub>4</sub> , Cr <sub>2</sub> O <sub>7</sub>	none	Cl	green
NO <sub>3</sub> , ClO <sub>3</sub>	faint yellow	HPO <sub>4</sub> , B <sub>4</sub> O <sub>7</sub> Na alum	faint green
MnO <sub>4</sub> <sup>2-</sup> , F	greenish yellow		

#### Luminescence by Canal Rays

Under the influence of canal rays a number of salts luminesce, and the color of the light is in some cases markedly different from that of cathodoluminescence. Table III including the results of Arnold<sup>1</sup> and of Schmidt<sup>2</sup> is given below. On the basis of the present hypothesis, it must follow that canal rays either cause a different kind of decomposition of the salt or at least admit of a different kind of recombination of its dissociation products.

It is interesting in this connection to refer to an observation of Schmidt, that carefully purified sodium chloride on exposure to canal rays luminesces at first weakly bluish, but that the red-brown or red-yellow fluorescence follows. This would indicate that the luminescence, and hence the chemical reaction characteristic of cathodo-excitation occurs momentarily, but is succeeded by the usual anodic phenomena.

Arnold furthermore observes that under the influence of canal rays sodium chloride, nitrate, sulphate, bromide, and

<sup>1</sup> Wied. Ann., 61, 326 (1897).

<sup>2</sup> Drude's Ann., 9, 703 (1902).

iodide all show the D line; and J. J. Thomson<sup>1</sup> writes "If a layer of lithium chloride is placed on the plate, then when struck by *Canalstrahlen* it shines with a bright red light and the red lines of the lithium spectrum are very bright; if the direction of the discharge is reversed so that the lithium chloride is struck by the cathode rays, its color changes from bright red to steely blue, giving out a faint continuous spectrum but not the lithium lines." Again, "In some cases the *Canalstrahlen* excite the metallic lines more strongly in compounds of the metal than in the metal itself, thus if we bombard the surface of the liquid alloy of sodium and potassium with *Canalstrahlen* the specks of oxide floating on the surface shine out with a bright yellow light and show the D lines of sodium strongly; the clean parts of the surface on the contrary are hardly luminous at all, and I have never been able to see the D lines on this part of the surface. The difference may be due in part to the sodium being much more volatile than the oxide, so that an atom of sodium struck by the *Canalstrahlen* may volatilize and get away from the surface, while a molecule of oxide would be fixed, thus the light might be much more concentrated when the surface struck is not volatile than when it is easily vaporized."

TABLE III  
Luminescence with Canal Rays

Substance	Fluorescence Arnold	Fluorescence Schmidt
Glass	reddish yellow	—
NaCl	reddish yellow	first bluish, then reddish yellow
NaBr	reddish yellow	reddish yellow
NaI	reddish yellow	reddish yellow
NaNO <sub>2</sub>	reddish yellow	reddish yellow
Na <sub>2</sub> SO <sub>4</sub>	reddish yellow	reddish yellow
Li salts	red	—
K salt containing Na	yellow	first weak bluish then reddish yellow
Sr salts	rose-white	—
Cd salts	yellow	yellow

<sup>1</sup> "Conduction of Electricity through Gases," 2nd Edition, 642 (1906).

### Luminescence by Ultraviolet Light

No systematic study of luminescence of salts under ultraviolet light has been attempted, previous workers restricting themselves chiefly to the study of minerals and phosphorescent sulphides. For this reason, experiments were made employing the same salts as included in Wilkinson's list for comparison of the quality of the emitted light in the two instances.

As a source of ultraviolet light an iron arc was constructed of two machine steel terminals, each  $1\frac{1}{4}$  inches by  $\frac{7}{8}$  inch by  $\frac{1}{4}$  inch fastened by means of machine screws and nuts to a 6 inch by 4 inch by  $\frac{1}{4}$  inch sheet of asbestos tile set vertically on a board. The length of arc could be varied by turning the terminals. An oil transformer connected through a suitable resistance with a 110 A. C. volt 60 cycle supply and having six large Leyden jars of 1100 square inches total tin foil surface and  $\frac{1}{8}$  inch thickness of glass in parallel with the secondary, furnished an arc of about  $\frac{3}{4}$  inch length under these conditions. The salt was placed in a small crucible about one-half an inch below the arc. On account of the intense light of the arc, fluorescence could not be observed, but strong phosphorescence resulted in all the salts which according to Wilkinson exhibited this property under cathode excitation. Table IV gives a summary of the results.

The coloration of the residue after about fifteen minutes' exposure to the light of the arc was remarkable in the case of the potassium halides, potassium chloride after excitation showing by daylight a dark amethyst color, potassium bromide a blue as pronounced as that of ammonium copper sulphate, and potassium iodide resembling nickel salts. The colors are doubtless due to free potassium modified by the respective free halogen. The colors faded in about a minute leaving the salts pure white. With the moist halides no phosphorescence was observed; it was hoped that under this condition, the potassium and chlorine as decomposition products would react in the presence of water to yield hydrogen and potas-

sium chlorate, but the amount formed—if any—was so slight that it could not be detected even by examination of the residue for anisotropic crystals of the chlorate under the microscope with crossed Nicols.

TABLE IV  
Luminescence with Ultraviolet Light

Salt	Phosphorescence	Color of residue	Thermoluminescence
NaCl	bluish white	brown	bluish white
NaBr	bluish white	brown	bluish white
NaI	bluish white	brown	bluish white
KCl	violet-blue	dark violet	bluish white
KBr	intense blue	blue	blue
KI	green	green	green
Hg' salt	none	black	none
Hg'' salt	none	black	none
CdCl <sub>2</sub>	blue-green	brown	blue-green
CdBr <sub>2</sub>	blue-green	brown	blue-green
CdI <sub>2</sub>	yellow	brown	yellow
CdSO <sub>4</sub>	yellow	brown	yellow

#### Luminescence by Heating after Excitation

If the salt be exposed to cathode rays or canal rays or to ultraviolet light, and the excitation be discontinued, phosphorescence occurs at first bright, then gradually decreasing until the light is no longer visible. In most cases, if the substance be now heated, intense luminescence occurs for a time, and then the salt can be made luminescent only by another excitation. Where the decomposition products of the salt are colored, thermoluminescence is accompanied by partial or complete restoration of the original color of the salt.

Thermoluminescence is most easily accounted for on the grounds of increased rate of diffusion and of increased rate of reaction of the decomposition products of the salt, brought about by raising the temperature.

It is important to note that the quality of light emitted in all cases of thermoluminescence is the same as that of cathodoluminescence or of luminescence produced by ultraviolet light. Even the residue of sodium chloride excited by



canal rays emits bluish light<sup>1</sup> when heated. The important bearing of this on the theory will be stated in the section on "Luminescence by Chemical Reaction." The data on thermoluminescence are given in Table IV.

#### Luminescence by Trituration

Crushing or grinding many crystalline substances will produce luminescence. The light is in most cases extremely faint, and the following procedure was employed to increase the effect. Where possible, the salts were fused in a platinum dish and cast in a graphite mould in sticks of one inch diameter and two inches length. These were pressed against a rapidly revolving carborundum wheel, and the luminescence was observed just beyond the point of contact of the salt and the wheel.

The phenomenon of triboluminescence is probably due to an actual separation of the constituents of the salt on breaking apart the crystals, and the reunion of these fragments of crystals permits recombination of the adherent decomposition products with production of light.

Table V contains the observations made; not a great deal of reliance can be placed on them, owing to the extreme faintness of the light.

TABLE V

Salt	Triboluminescence
NaCl	bluish white
NaBr	bluish white
NaI	bluish white
KCl	bluish white
KBr	bluish
KI	greenish white
CdSO <sub>4</sub>	yellow-white

#### Luminescence by Chemical Reaction (Chemiluminescence)

Pringsheim<sup>2</sup> substantiated the view that no gas emits

<sup>1</sup> Schmidt: *Drude's Ann.*, 9, 708 (1902).

<sup>2</sup> *Wied. Ann.*, 45, 429 (1892).

light save as a result of chemical action, and Armstrong<sup>1</sup> has ascribed luminosity and line spectra to the changes attending the formation of molecules from their atoms, or speaking generally, that they are consequences of chemical changes. Wiedemann and Schmidt<sup>2</sup> concluded that cathodoluminescence was due to the reaction of the products of decomposition of the salts, and the experiments of Wilkinson<sup>3</sup> confirm this view.

The light emitted during chemical change varies in intensity with the rate of reaction, and in some cases under different conditions may suffer complete change in color. Miss Stevenson<sup>4</sup> found that quinine sulphate on dehydration by concentrated sulphuric acid emitted a strong bluish light, which decreased in intensity on employing more and more dilute sulphuric acid as dehydrating agent. If the salt be dried over concentrated sulphuric acid, the light emitted is so faint that a photographic plate is not affected. But in all cases where luminescence could be observed there was no change in the quality of the light.

Nichols and Merritt<sup>5</sup> observed that with varying wave-length of exciting light there was no shift in wave-length of the maxima of fluorescence bands.

Trautz<sup>6</sup> has investigated the luminescence of a number of chemical reactions and has formulated the laws: The intensity of luminescence is about proportional to the velocity of the reaction, increasing enormously with the temperature; the color is dependent only upon the reacting system, being independent of the velocity of reaction or of the temperature.

On the other hand, the results of Wilkinson<sup>7</sup> would seem to indicate that a variation of color of the chemiluminescence of some reactions is possible. These apparent anomalies

<sup>1</sup> Proc. Roy. Soc., 70, 99 (1902).

<sup>2</sup> Wied. Ann., 54, 622 (1895); 56, 203 (1895); 64, 78 (1898).

<sup>3</sup> Jour. Phys. Chem., 13, 691 (1909).

<sup>4</sup> Ibid., 15, 854 (1911).

<sup>5</sup> Phys. Rev., 19, 18 (1904).

<sup>6</sup> Zeit. phys. Chem., 53, 1 (1905); Zeit. Elektrochem., 14, 453 (1908).

<sup>7</sup> Loc. cit.

will each receive its explanation as the individual cases are cited in the following sub-sections:

*Chemical Combination.*—In those cases where chemical reaction occurs with considerable velocity at ordinary temperature, the luminescence attending the chemical change can be observed without much difficulty. Thus, Wilkinson caused some reactions to occur slowly and then rapidly and observed in some cases marked differences in the color of the emitted light. His results are tabulated in Table VI.

TABLE VI

Reaction (slow, save where specified)	Chemiluminescence
Na + Cl <sub>2</sub>	blue
Na + Br <sub>2</sub>	blue-white
Na + I <sub>2</sub>	white
Rapid formation of Na compounds	yellow
K + Cl <sub>2</sub>	blue
K + Br <sub>2</sub>	blue
K + I <sub>2</sub>	green-white
Rapid formation of K compounds	violet
Hg + Cl <sub>2</sub> → HgCl <sub>2</sub>	greenish yellow
Hg + Br <sub>2</sub> → Hg <sub>2</sub> Br <sub>2</sub>	yellow-orange
Hg + I <sub>2</sub> → Hg <sub>2</sub> I <sub>2</sub>	orange to red
PbO + SO <sub>3</sub> → PbSO <sub>4</sub>	blue
CdO + SO <sub>3</sub>	yellow
Pb + (NH <sub>4</sub> ) <sub>2</sub> S <sub>2</sub> O <sub>8</sub> → PbSO <sub>4</sub>	bluish white

*Bunsen Flame.*—It is ordinarily supposed that the salts of the alkali metals in the Bunsen flame give but one spectrum for each metal, but Lenard<sup>1</sup> has found that, depending upon the position of the bead relative to oxidizing or reducing zones, for sodium, potassium, and lithium salts, two flames for each metal can be obtained. It will be seen from his results (Table VII) that the flames in the oxidizing zone are the ordinary ones giving the line spectra, whereas the flames obtained just at the boundary of the zones have more or less continuous spectra and correspond roughly to their cathodoluminescence. When one considers that these flames

<sup>1</sup> Drude's Ann., 11, 636 (1903); 17, 197 (1905).

are observed through the bluish flame of the Bunsen burner, and that the colors are further modified by the ordinary flames of the salts in the oxidizing portion of the Bunsen flame, it is not a matter of surprise that the agreement is no better.

TABLE VII  
Luminescence in Bunsen Flame

Salt	Color in oxidizing flame	Color in boundary
KNO <sub>3</sub>	violet	greenish yellow
KBr	violet	greenish yellow
KOH	violet	greenish yellow
KF	violet	greenish yellow
NaCl	yellow	bright greenish yellow
NaF	yellow	bright greenish yellow
NaBr	yellow	bright greenish yellow
RbI	violet	green
RbF	violet	green
Rb <sub>2</sub> SO <sub>4</sub>	violet	green
LiCl	red	blue
LiBr	red	blue
LiI	red	blue
Li <sub>2</sub> O	red	blue
Li <sub>2</sub> CO <sub>3</sub>	red	blue
Li <sub>2</sub> SO <sub>4</sub>	red	blue

Furthermore, Lenard<sup>1</sup> has noted the colors of the beads of fused salts. These results are in better agreement with the theory, since the beads could be removed from the flame when the quality of the luminescence was determined. The data are included in Table VIII.

TABLE VIII  
Luminescence of Fused Salts

Salt	Color of fused bead
Na	sky blue
K	strong green
Li	blue
Cs, Rb	yellow-green

<sup>1</sup> Loc. cit.

*Precipitation.*—Bandrowski<sup>1</sup> has examined a number of cases of crystallo-luminescence produced by precipitation, and has pointed out the necessity of bringing about precipitation rapidly in order that there shall be emitted a light intense enough to be visible. His experiments were repeated, lest chance impurity in the salts modify the results or lest our descriptions of the same color differ. Table IX contains the results, Bandrowski's data being given under the heading B.

These experiments are in a sense crucial in deciding the nature of the chemical reaction in the slow burning of sodium and the several kinds of luminescence of its salts, and the chemical reaction of rapidly burning sodium and the anodo-luminescence of its salts.

Thus a change from sodium as ion to the undissociated salt is the reaction causing the bluish luminescence, as expressed by the formulation



and—in want of further knowledge—we can postulate the reaction from Na without charge to sodium as ion as the cause of the yellow light ordinarily considered the flame spectrum of sodium, according to the formulation



In terms of this hypothesis, the observation of Schmidt, that sodium chloride under anode rays gives first a bluish then a yellow light, is accounted for, the reaction at first being the feebler one, later the more violent one.

The observations of Lenard<sup>2</sup> on the several spectra of sodium, and of Wood and Galt<sup>3</sup> on the fluorescence of sodium vapor would indicate, however, that this is not the sole hypothesis, and furthermore that several other reactions must be postulated to account for the several kinds of emitted light. In view of our present lack of knowledge on these points, any speculation would be premature.

<sup>1</sup> *Zeit. phys. Chem.*, 15, 325 (1894).

<sup>2</sup> *Drude's Ann.*, 11, 636 (1903).

<sup>3</sup> *Astrophys. Jour.*, 33, 72 (1911).

Of course the same line of reasoning applies to the reactions involved in the luminescence of the other alkali metals, lithium and potassium.

TABLE IX  
Crystalloluminescence

Salt	Alcohol in precipitant		HCl as precipitant	
	B	Farnau	B	Farnau
NaCl	bluish	bluish white	bluish green	bluish white
NaBr	—	bluish white	—	—
NaI	—	bluish white	—	—
KCl	green	bluish white	green	bluish white
KBr	(weak)	bluish (weak)	—	—
KI	—	greenish (weak)	—	—

*Electrolysis.*—Schluederberg<sup>1</sup> noted that on passage of an alternating current through dilute sulphuric acid, using lead electrodes, a greenish-white luminescence occurs at the electrodes, and Wilkinson<sup>2</sup> carried out a number of experiments using various electrodes and solutions. The results are given in Table X.

TABLE X  
Luminescence with Electrolysis

Electrodes and Ions	Luminescence
Cd + Br'	—
Cd + I'	intense yellow
Cd + SO <sub>4</sub> "	yellow
Cd + Cl'	—
Zn + SO <sub>4</sub> "	greenish white
Pb + Cl'	faint
Pb + Br'	bluish white
Pb + I'	yellow
Pb + SO <sub>4</sub> "	greenish white
Hg + Cl'	yellow-orange
Hg + Br'	brilliant orange
Hg + I'	orange
Hg + SO <sub>4</sub> "	greenish white

<sup>1</sup> Jour. Phys. Chem., 12, 623 (1908).

<sup>2</sup> Loc. cit.

The discrepancy in the colors of the luminescence by electrolysis or cathodo-excitation on the one hand, and of chemical reaction of lead oxide and sulphur trioxide on the other, is accounted for by assuming the reaction of neutral lead into lead as ion, or of lead as ion to undissociated lead sulphate for the former, and the reaction lead oxide plus sulphur trioxide yielding lead sulphate for the latter; according to the two formulations

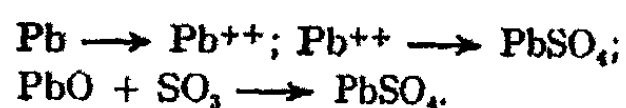

#### The Color of the Residue after Excitation

The color of the exposed salts is in all cases cited easily explained in terms of their decomposition products. But some observations of Tafel<sup>1</sup> suggest other factors. Zinc oxide after long exposure to canal rays darkens in color without appreciable loss in weight. This was ascribed to the bombardment by the  $\alpha$  particles, and this view was substantiated by submitting zinc oxide in a screw-press to a pressure of about 50,000 atmospheres, and by grinding the oxide in a mortar whereby extremely high local pressures are obtained; in each of these cases, darkening of the zinc oxide occurred. A pressure of 500 atmospheres in a hydraulic press caused no color change.

Furthermore, while the colorless oxide showed strong green anodoluminescence, none of the discolored varieties were active, nor was the oxide when prepared by precipitation of zinc sulphate with sodium carbonate, washing, and ignition at the temperature of the Bunsen burner. Tafel writes: "One must distinguish at least three forms of zinc oxide, one yellow-brown and two white. The colored and one of the white forms have lost the ability to fluoresce under action of canal rays." As a classification this is admirable; but unfortunately no explanation is offered, first, for the color change of the compressed oxide, unless tossing it into the scrap-heap of ill-defined allotropic modifications constitutes

<sup>1</sup> Drude's Ann., 11, 613 (1903).

an explanation; and, second, for the loss of ability to fluoresce under anodo-excitation.

It is true that in the latter instance, Schmidt's<sup>1</sup> explanation that zinc oxide shows anodoluminescence only when impurities are present is rejected by Tafel on the grounds that the zinc oxide prepared by precipitation with sodium carbonate, which surely contains adsorbed sodium salt, did not show fluorescence. This would seem to be a step backward, for it is well known that while traces of some impurities increase the luminescence of many salts, larger amounts either produce no further effect or actually cause a decrease until the luminescence has quite disappeared. Doubtless the preparation of zinc oxide by precipitation with sodium carbonate belongs to this latter class in that it contains too much impurity, and had the zinc been precipitated with ammonium carbonate instead, a much purer product would have been obtained which would have shown anodoluminescence.

A very simple and direct explanation of the color change of the oxide under pressure can be given. Amorphous zinc oxide, *i. e.*, the supercooled liquid, when massive may be assumed to be yellowish, but in finely divided condition, as obtained, for example, by combustion of zinc or ignition of one of the salts, is colorless. The same thing is observed on powdering copper sulphate or potassium dichromate or discolored rock-salt, each becoming lighter in color as the degree of fineness increases, until finally the substances are practically pure white. The explanation in terms of optics is obvious.

On the other hand, grinding may produce quite the opposite result; *e. g.*, if on the one hand arsenic or antimony be rubbed in a mortar, the crystals are broken up and a state of greater subdivision obtains; but if lead or gold powder be similarly treated, the particles do not become finer, but are merely spread out, *i. e.*, burnished, and where they overlap

<sup>1</sup> Drude's Ann., 9, 707 (1902).



are welded together, giving in each case the characteristic metallic luster. In like manner, zinc oxide will show this effect of burnishing, save that here the substance, being transparent, will give the color of its transmitted light. The phenomenon is not restricted to zinc oxide but is shown equally well by many amorphous substances, bismuth oxide, stannic oxide, zinc sulphide. Waentig<sup>1</sup> observed it in the case of phosphorescent alkaline-earth sulphides.

The decrease in fluorescence of discolored substances is of common observation. It is probably due to absorption of the active radiation by the discoloring impurity. If in the case of zinc oxide the discoloration under anodic excitation is solely due to a mere pressure effect, and no decomposition occurs, it could be accounted for by decrease of the total surface of the substance, since the effect of anodic and cathodic excitation is only superficial.

In order to imitate in the case of zinc oxide the crushing effect of grinding, the brittleness of the oxide was increased by pouring liquid air upon it in a porcelain mortar. If it be ground under the liquid air no discoloration is observed. On the other hand some, discolored by grinding at ordinary temperature, was ground under liquid air; it became colorless.

These observations shed light on another set of phenomena, the change of color of oxides when hot and cold. Zinc oxide when heated in a matrass in the Bunsen flame becomes yellow, but returns to its original color when cold. Bismuth oxide and stannic oxide, similarly treated, become darker when hot and lighter in color when brought back to room temperature, but do not become white again. Cooling of the heated oxides causes disintegration of the coalesced particles, and in their original state of fine subdivision the masses show more or less their original color. This disintegration is not complete in the case of bismuth and stannic oxides.

---

<sup>1</sup> *Zeit. phys. Chem.*, 44, 499 (1903).

An experiment was made of heating the surface of zinc oxide contained in a crucible with the point of an oxy-hydrogen flame. A good deal of volatilization of the material occurred, but on cooling, whereas the mass of material regained its original color, that which had sintered together by immediate contact with the flame remained yellow on cooling. It was still yellow after several months. The analogy is evident between the results of this experiment and the making of a poor and a good joint in glass-blowing.

According to Waentig, the activity of phosphorescent sulfides is increased by rapid cooling after ignition, and is decreased by grinding the substances in a mortar. All this is in line with the present explanation.

These results may seem a bit irrelevant to the matter at hand. The experiments were instituted merely to account for discoloration effects of pressure, and are not intended to correlate such color changes with those produced by anode-excitation.

#### **Color-Photography of Luminescence**

Manifestly, spectrographic investigation of the various sorts of luminescence is the ultimate criterion of the correctness of the hypothesis ascribing a common origin to luminescence, but lack of time and of the necessary apparatus prohibited this method. As a substitute for this more accurate method, color-photography was essayed. Dufay color-plates were employed on account of their reputed speed, ease of manipulation, and correct color rendition. The apparatus for production of cathodoluminescence was that already described. The plate was screened from X-rays by covering with lead foil all of the cathode tube save a small window just above the substance under excitation, the visible light being reflected by a mirror and focused by a lens onto the plate which was placed in a position not exposed to X-rays.

In some preliminary experiments, successful results were obtained with the highly luminescent minerals, willemite

(yellow-green) and fluorite (deep blue), and with a red-fluorescent sulfide.<sup>1</sup>

#### Summary

1. Luminescence is due to chemical reaction.
2. Increase of the rate of reaction by increase of temperature or by addition of a catalytic agent increases the luminescence.
3. The quality of the luminescence is but slightly altered by change of temperature.
4. The quality of luminescence is but slightly altered by the nature of the catalytic agent.
5. The quality of the luminescence is generally but slightly altered by the anion, being dependent almost wholly upon the nature of the cation; in a few cases a specific effect of the anion is noted.
6. The quality of the luminescence is independent of the method of production, *i. e.*, whether in a Bunsen flame, by electrolysis, precipitation, trituration, cathode rays, canal rays, ultraviolet light, chemical reaction, or as thermoluminescence; although in many cases it can be changed to another entirely different kind of light by particular modes of excitation, *e. g.*, by rapid chemical reaction or by canal rays.
7. The chemical reaction producing a given luminescence can in some cases be formulated; *e. g.*, sometimes being between molecular substances, in others passage from undissociated substances to ions, or *vice versa*.
8. Color-photography offers a means of somewhat more exact determination of the quality of luminescence.
9. As a minor point, the alteration of the color of compressed substances may be due, in some cases at least, to mere agglomeration of the substances, and not to formation of allotropic modifications of them.

---

<sup>1</sup> This portion of the research was conducted in collaboration with Mr. J. M. Lohr, and has been published in an original communication to the Eighth International Congress of Applied Chemistry, 20, 137. In a later paper now ready for publication (private communication), Mr. Lohr has substantiated the usefulness of the method in reproducing all save the faintest cathodoluminescence.

This research was suggested by Professor Bancroft and has been carried out under his supervision. I wish to express my sincere appreciation of his kindly criticism and encouragement during the progress of the work. My thanks are also due Professor Merritt for his helpful advice and for placing so liberally at my disposal the resources of the physical laboratory.

*Cornell University*  
*July, 1912*

## THE EFFECT OF LIGHT ON THE ELECTRICAL CHARGE OF SUSPENDED PARTICLES

BY S. W. YOUNG AND L. W. PINGREE<sup>1</sup>

With the extension of the theory of contact potential differences to suspended particles, the measurement of such potential differences and the determination of the various factors which affect them are becoming matters of increasing importance. This is perhaps especially true because the phenomena have in all probability a more or less intimate connection with many biochemical processes. Quite a considerable number of investigations have had for their purpose the determination of the character and value of the charge upon bacteria and upon the various toxic and antitoxic bodies developed under infection. This is in continuation of Bordet's idea that many, if not all, of the antigen-antibody reactions are explainable as colloidal reactions of one sort or another.

The determination of the charge on a suspended particle is no simple matter. It is usually done by subjecting the suspension to a given potential gradient (that is, by placing electrodes of known electromotive force at either end of a tube or trough containing the suspension) and noting the rate of migration in the one direction or the other. The rate of migration however depends upon a considerable number of factors, some of which are difficult to control. Thus, unless the suspension is electrolyte-free, changes in the character and concentration at the electrodes occur, and this causes a change in the value of the charge upon the suspended particle. The value of the charge also depends upon the size of the particles, that is, upon the degree of dispersion. This in turn depends upon a number of factors, that most difficult to control being the age of the suspension. As van Bemmelen has shown, the colloidal or suspension state is one of no rest, changes in aggregation and dispersion continually occurring.

<sup>1</sup> Abstracted from a thesis for the Degree of Master of Arts, presented by L. W. Pingree to the Faculty of Stanford University, May, 1913.

The case that a suspension maintains the same degree of dispersion over any considerable length of time is exceptional.

In addition to these and other difficulties is the fact that the tube or other vessel carrying the suspension is charged with respect to the medium, just as the suspended particles are. This results, in the potential gradient, in a current of medium flowing along the sides of the vessel, whose direction will be with or against the direction of migration of the suspended particles, according to the character of the charges of the vessel and of the particles with respect to the medium. Thus if the vessel and the particles both take on charges of the same sign, the current of the medium will flow counter to the direction of migration of the particles.

In two recent papers, Risdale Ellis<sup>1</sup> has developed a method whereby the effect of the counter-current is eliminated. The method consists in measuring the rate of migration under the microscope. The suspension is placed on a special slide, and is contained between the slide and the cover glass which are adjusted at a known distance from one another. By focussing the microscope at different depths within this layer of suspension, the rates of migration at the surface of the glass and at different distances from it are directly measured. From these data, with the aid of an integration formula, the true rate is determined.

The following investigation was undertaken in order to determine the limitations of the simpler method of measuring migration rates directly in U-tubes. This method has been considerably used, but is condemned by Ellis as unreliable. It would seem probable, however, that by increasing the diameter of the tube, a size would be reached where the effect of the flow of medium along the walls would be insignificant. In order to determine whether this were true, and if so what size of tube would be necessary, a set of U-tubes was made, all of uniform length, but of varying diameters. The diam-

---

<sup>1</sup> *Zeit. phys. Chem.*, 78, 321 (1911); 80, 597 (1912).

eters were, respectively, 3, 4, 5, 6, and 8.5 mm. The potential fall in the tubes was always 110 volts.

The first suspension subjected to investigation was one of colloidal arsenic sulphide, containing 1 gram to the liter of arsenic sulphide. This was prepared by the usual method of adding slowly to a solution kept saturated with hydrogen sulphide, a moderately dilute solution of arsenious acid. The excess of hydrogen sulphide was removed by bubbling pure hydrogen through, and the whole diluted to the above strength.

The rate of migration of arsenic sulphide suspensions depends very considerably on the details of the method of preparation. The presence of an excess of hydrogen sulphide noticeably accelerates, while an excess of arsenious acid greatly retards. (Unpublished results obtained in this laboratory by Mr. R. C. Pollock, and confirmed by Mr. Pingree.) For this reason a considerable stock of the reagent was made up and carefully kept in the dark and in tightly stoppered bottles.

The first set of results obtained are shown in Table I. The total length of liquid column was in all cases 21.5 cm. Under D is the distance wandered in centimeters. Under T is the time in minutes used in wandering the distance indicated under D. The two columns for each tube of different diameter represent parallels obtained in entirely independent experiments.

If one examines these results, it will be seen that they are in the first place very erratic. There is a general tendency to slow down after 3 or 4 cm have been traversed, which is in all probability due to slight accumulation and diffusion of acid around the cathode (from which the sulphide wanders) whereby the charge upon the particles as well as their degree of dispersion is somewhat reduced. This effect should, however, be more or less constant in all experiments and should not cause such wide variations as are shown. Temperature variations suggested themselves as a possibility in producing erratic results. Experiments were then undertaken to deter-

TABLE I

Diam. of Tube: D	8.5 mm T		6 mm T		5 mm T		4 mm T		3 mm T	
	A	B	A	B	A	B	A	B	A	B
1	6.5	7.5	6.0	7.0	6.0	7.5	6.0	7.0	9.0	6.0
2	5.0	8.0	5.0	6.5	5.0	7.0	5.5	5.5	5.0	7.0
3	7.5	10.5	6.0	9.5	5.5	9.0	8.0	12.5	6.5	11.0
4	8.0	11.0	7.5	11.0	5.5	9.5	10.0	15.0	9.0	17.0
5	10.5	15.0	9.5	13.0	8.0	15.0	15.0	15.0	12.5	19.0
6	11.0	15.0	13.0	17.0	12.0	19.0	19.0	19.0	16.0	—
Total time	48.5	67.0	47.0	64.0	42.0	70.0	63.5	77.0	58.0	60.0



mine the magnitude of the temperature coefficient of the migration. Measurements were made under otherwise like conditions (as was then supposed) at temperatures of 2, 45, and 70° C, respectively. The results are shown in Table II.

TABLE II

Temperature D	2 C T	45 C T	70 C T
1	11.5	4.5	2.5
2	16.0	5.0	3.5
3	18.5	6.5	3.5
4	23.5	7.0	3.5
5	28.0	10.5	3.5

Thus the magnitude of the temperature coefficient is quite considerable, although hardly great enough to explain the wide discrepancy of the results given in Table I as being due to temperature variations likely to occur in a water bath about a laboratory. However from this time on, precautions were taken to maintain the temperature constant, a temperature of 20° C being chosen. Other sets of experiments were carried out just as in those forming the basis of Table I, and at constant temperature, but these gave fully as erratic results.

A further inspection of Table I will show that, in the first place, the variation between parallels is in general far greater than that between measurements in tubes of different diameters. Taking, in the second place, the results of the first three sets of measurements, namely those in the 8.5, 6 and 5 mm tubes, it will be noticed that the first of each pair of parallels in all three cases agree very well indeed with one another, and that the same thing is true of the second series of these same three parallels. Especially is this to be seen from an inspection of the total time as given at the bottom of the table. That is, A results agree with one another, and B results agree with one another, but A and B results do not agree. In thinking over this apparently paradoxical situa-

tion, it occurred to us that the A results of the first three sets had been made on one day, and the B results on another, while the results of the last two sets (4 and 3 mm tubes), had been made at odd intervals. As the weather during this period had been very changeable, an alternation of light and dark days, it was thought possible that the rate of migration of the particles may have been somewhat influenced by unequal illumination on the different days. Plans were immediately made to test this hypothesis.

For migration in the dark a soap box was painted black on the inside and covered over with black cloth. In this was placed the migration apparatus in a constant temperature water bath, and along with it a small 10 volt lamp, which could be flashed occasionally in order to make the necessary readings. For migration in the light, apparatus was arranged so as to obtain exposure to direct sunlight, when such was available, and also a small 5 ampere carbon arc with a condensing lens was arranged so that it could be focussed on the migrating line within the suspension. Most of the measurements were made with the arc, as the weather was generally unsettled at that time. A Nernst lamp was also used occasionally.

Table III gives the results of a series of measurements made to determine the effect of illumination. The source of illumination was the carbon arc. Under  $T_L$  are the times of wandering in the light, and under  $T_D$  are the times of wandering in the dark. Table IV gives the results of another set of observations made in tubes 30 cm long.

An inspection shows very clearly the presence of a light effect on the rate of wandering of colloidal arsenic sulphide. The effect of illumination is invariably to retard the rate, and that to an extent which may (in 3 mm tubes) exceed 100 percent. The results obtained in the dark show a quite reasonable agreement considering the relative crudity of the apparatus and method used. The results in the dark given in Table IV were made rather more carefully, and show quite satisfactory agreement throughout. It may be stated that

TABLE III  
Length of tubes, 18 cm

Diameter of Tubes:	8.5 mm		6 mm		5 mm		4 mm		3 mm	
	T <sub>D</sub>	T <sub>L</sub>	T <sub>D</sub>	T <sub>L</sub>	T <sub>D</sub>	T <sub>L</sub>	T <sub>D</sub>	T <sub>L</sub>	T <sub>D</sub>	T <sub>L</sub>
1	5.0	8.5	4.5	9.0	4.0	11.5	5.0	10.0	4.0	11.0
2	5.5	6.0	5.6	7.0	4.0	4.5	5.0	8.5	4.5	9.5
3	6.0	6.5	5.5	7.5	4.0	5.5	5.0	9.0	5.0	10.5
4	8.0	9.0	6.0	9.0	6.0	5.5	7.0	11.5	6.0	12.5
5	11.0	12.5	9.0	12.5	10.5	10.5	9.5	12.0	8.5	13.0
Total time	25.5	42.5	30.6	45.0	28.5	37.5	31.5	51.0	28.0	56.5

all determinations were made in duplicate, and that the agreement between duplicates made in the dark was always quite good. The results in the light do not show as good agreement, although invariably showing a much lower rate than those in the dark. There is a quite constant tendency in the case of measurements made in the light to show an increased rate after the first centimeter, which later falls off again. This increased rate, however, never becomes as great as the corresponding rates in the dark. For this phenomenon we have no explanation at present.

TABLE IV  
Length of tubes, 30 cm. Diameter of tubes, 4 mm

D	T <sub>D</sub>		T <sub>L</sub>
1	5.5	6.0	10.0
2	6.0	5.0	10.5
3	7.0	6.0	11.5
4	8.0	8.5	13.0
5	11.0	10.0	20.0
Total time	37.5	35.5	65.0

As to the influence of the diameter of the tubes on the rate of migration, the results in the dark show nothing more than fluctuations to be expected from the present degree of experimental accuracy. The results in the light might at first be taken to indicate that under conditions of illumination, there is a distinct tendency toward slower migration in the tubes of smaller diameters. That this is to be definitely ascribed to flow of medium along the glass seems, however, rather doubtful. If the current is counter to the direction of migration of the particles, as has been shown by Ellis<sup>1</sup> to be the case for glass vessels carrying negatively charged suspensions in water, the effect of such counter-current will consist of two factors working in opposition to one another. In so far as the current is one of medium only, it will give an

<sup>1</sup> Loc. cit.

apparent acceleration to the migration of the suspended particles. In so far as the counter-current carries suspended particles with it, it will tend toward an apparent negative acceleration of the particles. It will be difficult, therefore, to tell in any given case what the effect will be. Ellis's measurements were all made on columns of liquid about six-tenths of 1 mm in thickness, and consequently throw little light on the conditions in much thicker columns. The frequent occurrence of a curved surface of migration, noted by various investigators, appears at first sight to lend support to the theory of a large counter-current effect. From our observations, however, this is not necessarily the case. We have frequently observed this phenomenon, especially with bacterial emulsions. In some cases such surfaces will develop to a very marked degree, so much so occasionally as to form a hollow cone 2 cm or more in depth, while in what should be a perfect parallel experiment, the migration surface will remain quite flat. While there can be no doubt that the counter-current effect is a real one, we are rather inclined to think that quite a great portion of the reduction of migration rate in small tubes (Table III) is due to a different cause. If one considers that when a bundle of rays of light normally strikes the surface of a cylinder, these rays are refracted to a focal line or axis, it will immediately be seen that the location of the focal line will depend upon the refractive index of the material of the cylinder, and upon its diameter. In larger cylinders it will lie without the cylinder, while in smaller ones (of shorter radius) it may lie within. In any event, the smaller the radius of curvature of the cylinder, the stronger will be the convergence of light within it. Thus with tubes of small diameter the intensity of illumination will be greater than in those of greater diameter, under the same source of illumination, whence a greater retardation will be found in small than in large tubes. This seems especially plausible since this effect is only to be found when illumination occurs. The rates in the dark are roughly independent of the diameters of the tubes used. In order to settle these matters satis-

factorily, it would seem wise to work with flat-sided tubes, in order to avoid uneven distribution of light, and plans for such an investigation are under way. In the meantime it seemed advisable to extend the work to other colloids and to other factors which might throw more light on the general phenomena of light sensitiveness.

Before leaving arsenic sulphide, however, the results of measurements to determine the effect of small amounts of acid and alkali upon the rate of wandering will be given. These are most instructive when plotted as curves, which has been done in Fig. 1. Ordinates are distances in centimeters,

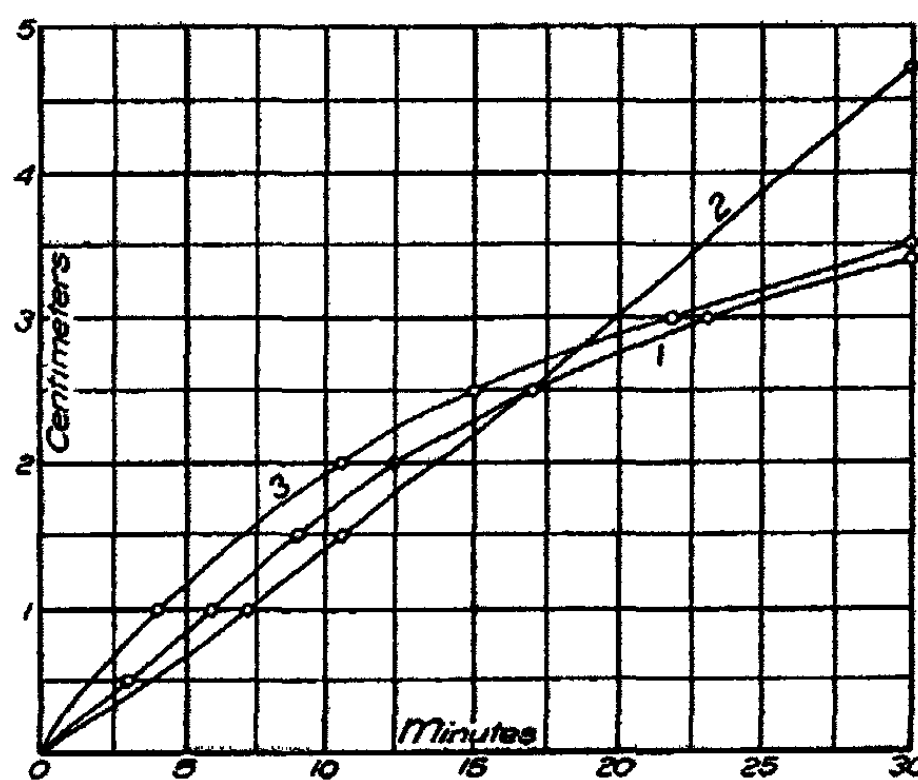

Fig. 1.—Plot of Migration in Arc-light Illumination

- Curve (1)  $\text{As}_2\text{S}_3$  of concentration 1 gr. per liter  
 Curve (2)  $\text{As}_2\text{S}_3$  of concentration 1 gr. per liter, N/1000 with NaOH  
 Curve (3)  $\text{As}_2\text{S}_3$  of concentration 1 gr. per liter, N/1000 with  $\text{H}_2\text{SO}_4$

while abscissae are total times in minutes. It will be noticed that in the thousandth normal acid there is at first a considerable acceleration which, however, soon falls off. It appears most probable that the initial acceleration is perfectly normal, and that the subsequent falling off is due to a

slow increase in the aggregation of the particles. In the case of the alkali, the first effect is a reduction in the rate, followed later by an increase. This is explainable in the same way, that is, as due to a subsequent gradual increase in the degree of dispersion of the particles. If this reasoning is correct, it seems safe to say that the effect of acid is to accelerate and the effect of alkali is to reduce the rate of migration, but that both produce subsequent changes in the degree of dispersion of the suspended substance, which more or less obscure the earlier and normal effects.

#### Experiments with Colloidal Ferric Hydroxide

Colloidal ferric hydroxide was prepared by the usual method of hydrolysis. Ferric chloride was used and the hydrolysis carried on for ten days or more. At the end of this time the hydroxide was found to be in a somewhat flocculated condition. Migration experiments were carried on with this material as well as with samples of it to which minute amounts of dilute acetic acid had been added, followed by boiling, in order to increase the degree of dispersion. Table V gives the results of these measurements. Instead of following the migration centimeter by centimeter, the total distance wandered after a certain time was determined. This was thought to be sufficient, as only comparative results were needed at this time. In Table V the total time allowed was 27 minutes. Sample 1 was the original dialyzed material. Sample 2 contained a very small amount of acetic acid, and results are given in duplicate. Sample 3 contained a somewhat greater amount of acetic acid. The carbon arc was used for illumination.

TABLE V  
Time of migration, 27 minutes

Sample	$D_D$	$D_L$
1	5.3	5.0
2	4.3	4.0
2	4.4	4.0
3	3.4	3.2

Thus there is an invariable reduction in the migration rate of ferric hydroxide under the influence of illumination. A far greater number of measurements were made than are reported here, always with the same result. Thus, while the effect is a relatively small one, amounting to only 6 or 8 percent, there is no reason to doubt that the phenomenon is a genuine one. The results are of especial interest at this point, as the ferric hydroxide is a positively charged colloid, whereas arsenic sulphide is negatively charged.

#### Gum Mastic

Emulsions of gum mastic were prepared by dissolving the gum in absolute alcohol, and adding a few drops of the solution to a considerable volume of pure water. Three emulsions of different concentrations were prepared, sample 1 being the most concentrated, and sample 3 the most dilute. The results are given in Table VI.

TABLE VI  
Time of migration, 21 minutes. Arc light used

Sample	$D_D$	$D_L$
1	0.45	0.90
2	2.5	3.3
3	3.2	4.2

Here it is seen that the acceleration under the influence of light is positive and of very considerable magnitude, reaching in case of sample 1 a value of 100 percent. The rapid increase in migration rate with increasing dilution, that is, with increasing degree of dispersion, is very clearly shown.

#### Common Rosin

Emulsions of common rosin were prepared by the same method as was used with the gum mastic, and their migration rates measured both in the dark and under arc-light illumination. The results were precisely like those with mastic emulsions, except that the light sensitiveness was somewhat



less, amounting in some cases, however, to as much as 30 or 40 percent.

### Chlorophyll

A quantity of chlorophyll was prepared by extracting green grass with alcohol, evaporating at room temperature to dryness, and again extracting with a small amount of absolute alcohol. There was thus produced a highly concentrated solution which showed reddish brown by reflected, and deep olive-green by transmitted light. Emulsions were prepared by adding a few drops of this solution to considerable volumes of water, and measurements of migration rates in the dark and under arc-light illumination were carried out. The results of a few of these measurements are given in Table VII.

TABLE VII—CHLOROPHYLL  
Time of migration as specified  
Arc-light illumination used

Sample	Time Min	$D_D$	$D_L$
1	15	5.3	5.6
2	11.5	4.2	4.4
3	10	3.4	3.9
4	10	3.8	4.1

The chlorophyll showed itself to be negatively charged like mastic and rosin. After wandering for a few centimeters, the migration surface became wavy and uncertain, so that the times of migration are all rather short. Again a positive acceleration is invariably shown, whose value is, however, smaller than for mastic or rosin.

### Experiments with Bacteria

It is a well-known fact that bacteria, when suspended in aqueous solutions, are in general negatively charged with respect to the medium, and consequently, when placed in a potential gradient, they wander toward the anode, just as do arsenic sulphide, mastic and the like. It was thought to be of interest at this point, to determine whether or not they, too,

were influenced in this respect by light. Cultures of several species were started, and kept on hand by transplanting on agar slants, by the usual method. The species mostly used were *Sarcina flava*, *Sarcina rosea*, and *Bacillus prodigiosus*.

Emulsions of these bacteria were prepared as follows, using isotonic glucose solution as the dispersing medium in order to avoid electrolytes: Into the slant in which was a well-developed culture, a couple of cubic centimeters of the glucose solution were placed, then with a sterile platinum loop the bacteria were scraped loose from the agar and rubbed up with the glucose to a smooth, thick emulsion, care being taken not to disturb the agar bed of the slant. This emulsion was then poured off, the tube rinsed with another small portion of glucose solution, which was added to the first. The whole of this emulsion was then diluted to 15 or 20 cc with glucose solution, which gave from one culture sufficient material for a number of measurements.

In Table VIII is given a set of the results thus obtained.

TABLE VIII  
Time of migration, 20 minutes  
Arc-light illumination

Species	$D_D$	$D_L$
<i>S. flava</i>	5.0	4.0
<i>S. rosea</i>	4.2	3.2
<i>B. prodigiosus</i>	3.8	3.0

In Table IX are the results of measurements on *B. prodigiosus* to determine approximately the relative effects of sun and arc light.

TABLE IX  
*Bacillus prodigiosus*. Time of migration, 20 minutes

$D_D$	$D_{Arc}$	$D_{Sun}$
4.4	3.6	3.6

Thus bacteria, like arsenic sulphide, experience a considerable reduction in their rate of wandering under the influence of illumination, and sunlight and the carbon arc are roughly equal in their effects. A large number of results have been obtained, but only a few are given here, for the reason that the conduct of bacteria at times seems very complex. For example, the migration rate for a given species seems to vary in different cultures. Furthermore, the measurement of the rate of wandering in the light is often complicated by the formation of most curious migration surfaces. Very deep conical surfaces are sometimes formed, so that the bacteria near the surface of the glass of the tube (where illumination is most direct) seem scarcely to wander at all while those in the axis (or near it) of the tube wander quite well. Curiously enough it, very often happens that the axis of the conical surface is considerably displaced, giving rise to such surfaces as are shown in Fig. 2, the source of

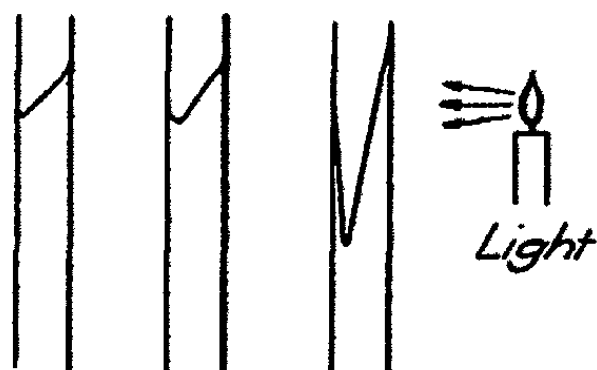

-Fig. 2-

illumination being considered at the right. It is believed that these phenomena are all to be explained as due, in the main, to unequal distribution of light in the tube, and it is hoped that experiments with flat-sided tubes will settle this matter.

A considerable number of experiments have been carried out for the purpose of determining the differences in conduct of dead and living bacteria, if such exist. While this work is by no means complete, such results as have been obtained seem to indicate quite clearly that the rate of wandering of dead bacteria is considerably less than that of live ones, and

that their light sensitiveness is also somewhat less, although it does not seem to disappear entirely. The work has been greatly hampered by the formation of irregular migration surfaces in the light.

The influence of the presence of small amounts of acid and alkali on the migration rate of *B. prodigiosus*, both in the dark and in the light, was also determined. The results are shown in Table X. Similar determinations were also made using *Sarcina rosea*, and gave perfectly similar results, except that the taking of readings in the light was very difficult, owing to the irregular migration surfaces. It has been our experience in general that, for some reason, *B. prodigiosus* gives more even surfaces in the light than do the *Sarcinae*.

TABLE X—*B. PRODIGIOSUS*  
Time of migration, 30 minutes

Solution	D <sub>D</sub>	D <sub>L</sub>
Neutral	5.5	5.0
Neutral	5.4	5.0
N/1000 H <sub>2</sub> SO <sub>4</sub>	5.6	5.3
N/1000 H <sub>2</sub> SO <sub>4</sub>	5.8	5.4
N/1000 NaOH	5.2	4.8
N/1000 NaOH	—	4.8

Thus the migration rate is accelerated measurably by small amounts of acid and retarded by like amounts of alkali, and the effect is shown both in the light and in the dark. Larger amounts of acid are known to retard the rate of wandering very materially, in fact, bacteria may be made to wander in the opposite direction, toward the cathode, by sufficient acid concentration. In small amounts there is however an acceleration and this completely in keeping with the conduct of arsenic sulphide.

#### Discussion of Results

In the foregoing it has been shown that all suspensions, emulsions and colloidal solutions investigated show a very distinct light-sensitiveness with respect to their rates of

migration in the electrical potential gradient. In some cases the effect is a positive, and in other cases a negative acceleration. This effect is readily explainable in either of two ways:

(1) The influence of light is to affect the degree of dispersion of the suspended matter, increasing the dispersion in cases of positive acceleration and reducing it in cases of negative acceleration.

(2) The influence of the light is a direct one upon the static charge carried by the suspended particles, increasing this charge in case of positive accelerations, and reducing it in the case of negative accelerations.

If it were not for the fact that bacteria, whose degree of dispersion cannot alter in any ordinary sense of the word, are also affected by light as are other suspensions, it might be difficult to choose between the two hypotheses. But since bacteria cannot well change their degree of dispersion, it seems certain that, at least in their case, the effect must be upon the value of the normal static electrical charge which they carry. It is also highly probable that in other cases also at least a considerable portion of the effect is to be ascribed to the same cause, although changes in the degree of dispersion may also occur. In fact such changes in the degree of dispersion would in all probability naturally follow as a result of the change in the value of the charge, since it is usually considered that the degree of dispersion or aggregation is, to a great extent, dependent upon the charges carried by the suspended particles. While it is not true that coagulation or agglutination occurs always at the isoelectric point, that is, at the point where the potentials of the particles and medium become equal, it is nevertheless quite certain that in a general way the approach toward the isoelectric point favors such a result.

It seems most plausible at the present time to consider the above-described effect as primarily a photo-electric one, and any changes in dispersion which may occur as resultant and secondary. In this connection it is interesting to note that Freundlich and Schucht<sup>1</sup> have recently noticed that the

<sup>1</sup> Freundlich and Schucht: *Zeit. phys. Chem.*, **80**, 564 (1912).

reaction between colloidal arsenic sulphide and certain cobalt-ammonium salts is light-sensitive to a high degree. Bovie<sup>1</sup> finds that albumen and other proteins are not only coagulable by ultraviolet light at low temperatures, but that many reactions of decomposition, similar to those occurring on heating, also take place. The coagulation is readily explained as due to a reduction of the electrical charge, and since, as Freundlich and Schucht's work shows, chemical reactions may be accelerated between a colloid particle and a substance dissolved in the medium and probably with the medium itself when the system is exposed to light, it is quite possible that Bovie's decompositions are to be explained as fundamentally photo-electric effects.

The experimental results reported in this paper lead quite naturally to an interesting theory of free oxidation, especially in heterogeneous systems, as well as to a simple photo-electric theory of photochemical action in general. This theory will be discussed in a subsequent paper. The results obtained suggest many lines of further investigation, some of which are already under way, and others will be started as soon as possible. A mercury quartz arc and quartz migration tubes are also being provided, in order that the investigations may be extended into the ultraviolet field, where, it is natural to suppose, much larger effects will be found.

*Stanford University, Cal., May 29, 1913*

---

<sup>1</sup> Bovie: *Science*, 35, 24 (1913).

## COLOR PHOTOGRAPHY OF LUMINESCENCE

BY J. M. LOHR

It was pointed out in a preliminary paper<sup>1</sup> that successful use had been made of color photography to determine the quality of the visible light emitted during cathodoluminescence, and that in the preliminary experiments, photographs of the light from highly luminescent minerals such as willemite (yellow-green) and fluorite (deep blue), and from a red fluorescent sulphide had been obtained.

This paper deals with the photographing of the much fainter cathodoluminescence of salts of the alkaline halides and some other salts, and of the flames of various substances.

### Cathodoluminescence

The cathodoluminescence was excited by exposing to cathode rays substances contained in an 8 inch by 1½ inch cathode tube consisting of two halves connected by a ground joint and a mercury seal. The lower half contained the substance and the upper half the ring anode and disc cathode. The tube was mounted on a wooden framework in such a way that the body of the tube proper was inclined about 30° from the vertical, thus allowing the side arm of the cathode tube, which is joined to its lower half, to rest in a horizontal position. A ground-glass hollow stopper leading from this horizontal arm was fused to a glass tube which led to the vacuum pump. A small glass pan or spoon mounted on a glass rod support about 3 inches high and tipped slightly in front from the horizontal was placed in the tube for the purpose of holding the substances. A small wooden box painted black and with part of the bottom removed was placed down over the cathode tube and held securely in position at the bottom. The front of the box was beveled so that the cover or door rested in a slanting position and parallel in front to the en-

<sup>1</sup> Farnau and Lohr: Eighth International Congress of Applied Chemistry 20, 137 (1912).

closed cathode tube. This door, save for a small round hole opposite the spoon holding the substance to be used under the cathode rays, was covered with lead to cut off the X-rays. The light emitted by the action of the cathode rays on the substance under consideration passed through the small opening in the front of this closed box and through a condensing lens to a mirror placed at such an angle that the rays striking it were reflected downward in a vertical path so as to strike the color plate placed in a horizontal position. The color plate in this position was out of the range of any X-rays which might come through the opening in the box. This simple mechanical arrangement was very satisfactory and rendered easy the introduction of new substances into the tube.

The vacuum was maintained by means of a two-cylinder Geryk oil pump and a Gaede rotary mercury pump, connected in series. For substances very highly luminescent, such as willemite, the vacuum from the Geryk pump was sufficient, but for the much fainter light of most of the salts used in this work, the addition of the Gaede pump was necessary. When using these pumps in series, the Geryk pump was first used to obtain a vacuum of about 20 mm of mercury, at which point the Gaede pump was started and both were run together, the Gaede pump serving to evacuate the tube, and itself in turn being evacuated by the Geryk pump. Motion to the two pumps was supplied by a small motor placed between them.

An induction coil furnished electrical energy. It was connected to the 110 volt circuit through a bank of lamps placed under a box lined with asbestos, and the terminals of the coil were connected to the terminals of the cathode tube through rubber stoppers fastened in the box covering, and serving as insulators from the lead covering of the box.

The whole apparatus was set up in a dark room which acted as a camera.

Dufay color plates were used. As the light from most of the substances was rather faint, the rays had to be condensed to a circular image of less than an inch in diameter. For this reason it was not necessary to use the plates of the



regular lantern size,  $3\frac{1}{4}'' \times 4''$ , but each plate was cut into four parts, and a single exposure taken on each part thus obtained. (Smaller plates of about  $1\frac{3}{4}'' \times 2''$  may be gotten by order from Paris. This would be preferable, as the plates must be cut in the dark, and in spite of the greatest precaution, small particles of glass quite frequently stick to the emulsion of the plate and cut it, thus rendering it useless for a perfect slide.)

The materials used under the cathode rays were C. P. salts, dried in the oven at the proper temperatures or, in some cases, fused. They consisted of sodium bromide, chloride and iodide, potassium bromide, chloride and iodide, anhydrous cadmium sulphate, cuprous iodide and mercurous chloride. The sodium iodide was made anhydrous by crystallizing from alcohol and drying with ether.

The times of exposure to obtain the best photographs varied somewhat for each substance, being anywhere from three to ten minutes, and were determined by preliminary trial. This was usually done by taking for each substance a number of exposures side by side on a single plate, varying the time and developing, after which it was determined just what time of exposure gave the best results. The stronger blue light from potassium bromide, potassium chloride and sodium bromide was easily photographed, requiring about five minutes' exposure. The plates were also very sensitive to the green from potassium iodide but only slightly sensitive to the paler blues from the faint luminescence of sodium iodide and sodium chloride. For the last two, ten minutes seemed to give the best results, but with such a long exposure of the salts to the effect of the cathode rays, the color of the rays seemed to be obscured by a dark coating over the salt, presumably a decomposition product. Exposures of various lengths were made, but it was impossible to obtain a correct color representation on the plate. It was also very difficult to obtain a correct image of the yellow from cadmium sulphate. In every case, after developing the plate, the photograph had a slight greenish tint. The color plates were very

sensitive, however, to the beautiful orange from mercurous chloride, but an exposure of more than 10 to 15 seconds resulted in the salt becoming covered with a dark coating, presumably an emulsion of mercury and mercurous chloride, which obscured the color rays. This was avoided by placing the plate holder in permanent position and taking single exposures of ten seconds each, on the same part of the plate, after which the plate holder was closed, the current stopped, and fresh salt introduced into the tube. This was a long, tedious process, requiring time for a vacuum after each introduction of salt, but twelve such exposures on the same plate produced very good results.

#### **Flame Luminescence**

This work was done in the hood of one of the laboratories made totally dark. The substances were usually burned in the flame of a Bunsen burner, behind a screen of black paper, containing a small opening just above the substance to be burned. The plate holder was held in a vertical position by a clamp fastened to an iron stand, and a condensing lens was interposed. The substances were held in different ways over the Bunsen burner depending upon the nature of the substance. It was not difficult to obtain characteristic flames of the different substances, but considerable trouble was encountered in producing flames of perfectly pure color unmixed with that of the Bunsen flame itself, or that of the oxidized substance already formed by the burning.

The flames of sodium, potassium, lithium, arsenic, copper, and boric acid were photographed.

For sodium and potassium, the best results were obtained by placing the carbonates in a small boat-shaped basket of platinum wire, held by an iron stand just below the opening in the screen in front of it. By so placing the burner that the flame would split on the edges of the basket toward the screen, the half of the flame facing the screen would shoot upward giving a sheet of the characteristic colored flame, sufficiently broad to cover the range of the circular opening in the screen,

and would thus produce a circular image on the photographic plate. Both the sodium and potassium flames were easy to photograph, but different exposures ranging from two to ten minutes produced different intensities of the image on the plate, all of which were readily distinguishable when reproduced from the lantern. The same method was used for lithium, but it was almost impossible to obtain the characteristic bright red flame in volume, purity, and for a length of time sufficient for a successful exposure.

The yellowish green flame of boric acid was obtained in a manner similar to that used for the above-mentioned salts.

The playing of the Bunsen flame over metallic copper gives a beautiful, clear green flame to which the color plate is very sensitive, but after about a minute of burning, the green flame becomes diluted by yellow, probably caused by the oxidized copper. This was avoided by causing the flame just to graze the folded edge of a piece of copper gauze placed at an angle of about  $45^\circ$ . By this method the clear green copper flame could be produced for a time sufficiently long for an exposure.

In all of this flame work the best results were obtained by using a fish-tail attachment to the burner, with the slit made wider and shorter so as to produce a flame having a cross section almost square.

An effort was made to photograph the bluish white zinc flame, but it is extremely difficult to obtain such a flame of sufficient volume and without interference flames from the burner. The rapid formation of zinc oxide at the surface of the molten zinc also tends to interfere with the formation of a flame suitable for photographing.

Photographs of mercury vapor were also taken, but they were difficult to recognize when thrown on the screen from the lantern on account of the similarity to white light.

The plates after being developed were made up into lantern slides. But before preparing the slides, the plates after thorough drying were tested out in the lantern, and some

interesting limitations of the Dufay plates for lantern slides were observed. In practically every case, the colors blue, green, etc., as exhibited on the plates, when left in the lantern continuously for about five minutes, would be replaced by variegated colors of different hues. When, however, the plates were allowed to remain in the lantern for spaces of one-half to one minute, withdrawing and allowing to cool each time, they could be thus successively used in the lantern an indefinite number of times without change of color. To test the effect of heat and light separately, a plate bearing the image of blue light from the cathode excitation of potassium bromide was placed in a dark oven at 70° C and found to change color within three to five minutes. Another plate was placed on the window ledge of the laboratory in the direct afternoon sunlight and was found to change color in several hours. Also several plates of potassium bromide were allowed to lie in the laboratory on a table exposed to daylight but not to sunlight, and were found to change color after several weeks. The cause of this changing of color or "fading" under the influence of heat may be due to the decomposition of the dyes on the plate, but is more likely due to the unequal expansion and contraction of the gelatine film on the plate. The slide consists of the complete rulings of ink or dye, patches of which are masked by opaque silver contained in a superposed gelatine film. The heat of the lantern very likely causes unequal expansion and contraction of the gelatine film owing to the probable presence of moisture, thus causing the patches of silver to move out of position with respect to the color rulings and thus expose other colors. It is not evident just why daylight should produce such changes of color.

The plates were made up into lantern slides of size 3 $\frac{1}{4}$ " by 4". The smaller-sized plates already mentioned bearing the images were inlaid in the center of a cardboard of the size 3 $\frac{1}{4}$ "  $\times$  4" and of the same thickness as the glass plate. This was then covered on the emulsion side by black paper, with a circular opening just over the image, and next to this

was placed a cover glass. On the other side of the cardboard bearing the glass plate was placed thin black cardboard also having a circular opening just over the image and the whole was bound around the edges by tape. To compare the gradation of colors, the three plates from sodium salts were made up into one, as were those of the potassium salt, thus producing rather effective slides.

**Summary**

Successful use is made of color-photography to determine the quality of the visible light emitted during cathode luminescence and also the quality of light emitted by the flames of various substances.

The Dufay plates are not particularly sensitive to the very faint cathodoluminescence of some of the halogen salts.

In the use of the Dufay color plates for lantern slides, the intense heat and light of the lantern place a limitation on the length of time that the slide should be left in the lantern.

This work was taken up at Prof. Bancroft's suggestion, and I desire to thank him and also Mr. E. F. Farnau for many helpful suggestions. I also wish to thank Dr. R. P. Anderson for the use of the spectroscopic laboratory and dark room.

*Cornell University, Sept., 1912*

## A NOTE ON THE ROLE PLAYED BY THE CARBONATE IN PHOTOGRAPHIC DEVELOPMENT<sup>1</sup>

BY J. HOWARD MATHEWS AND FLOYD E. BARMEIER

The statement is commonly made that the function of the carbonate in a photographic developer is to open the pores of the gelatin so as to provide readier access for the developer to the altered silver halide grains.

No record of any measurements on the rate of diffusion of carbonate solutions into gelatin having come under the observation of the writers it seemed to us to be highly desirable to make such measurements.

A rather thick gelatin solution containing a trace of phenolphthalein was cast in glass tubes of  $\frac{1}{4}$  in. diameter and allowed to set. The tubes were then cut off sharply so as to produce a square edge and the gelatin was cut square across with a sharp knife. The tubes so prepared were placed in solutions of sodium and potassium carbonates, care being taken to ensure their being immersed to the same depth.

The carbonate diffused into the gelatin and produced a pink color having a very sharp boundary. The rise of the pink column in the tubes was accurately measured by a good cathetometer.

It was found that the rate of diffusion increased with the concentration up to a certain limit and then fell off again. This may be due to a hardening action of the carbonate on the gelatin. It is curious, and significant, to note that the solution having the greatest rate of diffusion is one having a concentration of carbonate which is the same as is customarily used in a normal developing solution.

Judging from the form of the accompanying curves which give the behavior of the solutions investigated, it seems likely that there is a certain strength of carbonate solution which

---

<sup>1</sup> A paper read before the Eighth International Congress of Applied Chemistry in New York, September, 1912.

would diffuse more rapidly than any other, and that in all probability this would be the concentration most desirable in a developer. Lack of time has prevented our making further determinations along this line. It seems likely that this optimum value for the concentration of the carbonate solution depends on the particular gelatin used, and possibly on the water content of the solidified gelatin on the plate.

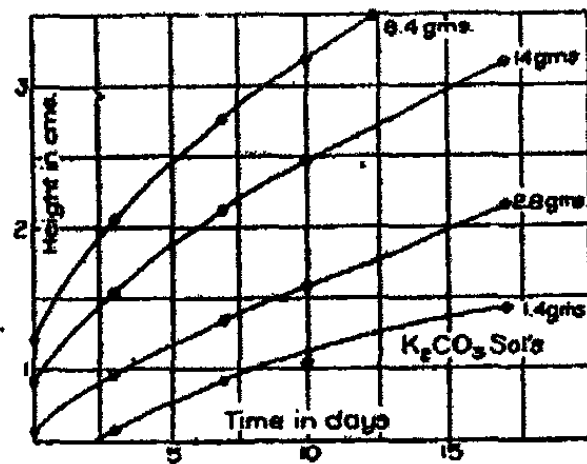

Fig. 1

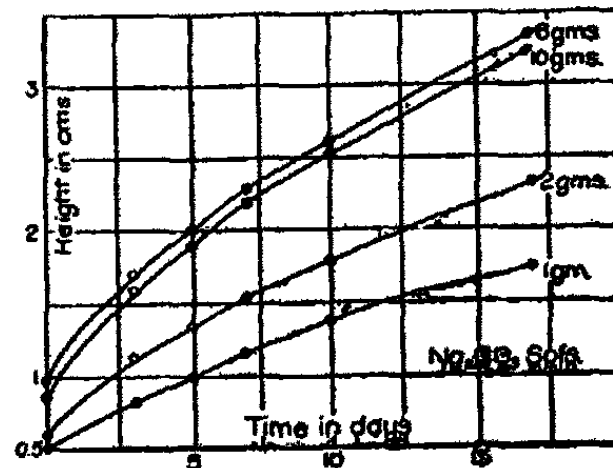

Fig. 2

These measurements support the statement that the function of the carbonate is to open the pores of the gelatin—though this probably is not the whole story—and the accompanying curves show why the carbonate may vary within certain, yet rather wide, limits.

The data obtained in these measurements, and the curves derived therefrom, appear below :

Time at which readings were taken	Height of Colored Column Amount of $\text{Na}_2\text{CO}_3$ in 100 cc.				
	1 gm	2 gms	6 gms	10 gms	14.0 gms
3/13 2 : 30 P.M.	0.520 cm	0.579 cm	0.970 cm	0.932 cm	
3/16 11 : 00 A.M.	0.834 "	1.118 "	1.664 "	1.582 "	
3/18 12 : 00 M.	1.002 "	1.344 "	1.940 "	1.924 "	
3/20 2 : 00 P.M.	1.168 "	1.542 "	2.242 "	2.216 "	
3/23 11 : 00 A.M.	1.346 "	1.764 "	2.590 "	2.556 "	
3/30 11 : 00 A.M.	1.742 "	2.332 "	3.248 "	3.314 "	
4/12 10 : 00 A.M.	2.222 "	3.064 "	4.262 "	4.267 "	

Time at which readings were taken	Height of Colored Column Amount of $\text{K}_2\text{CO}_3$ in 100 cc.				
	1.4 gms	2.8 gms	8.4 gms	14.0 gms	14.0 gms
3/13 2 : 30 P.M.	0.342 cm.	0.582 cm	1.220 cm	0.906 cm	
3/16 11 : 00 A.M.	0.582 "	0.976 "	2.048 "	1.558 "	
3/18 12 : 00 M.	0.800 "	1.224 "	2.430 "	1.846 "	
3/20 2 : 00 P.M.	0.948 "	1.360 "	2.790 "	2.130 "	
3/23 11 : 00 A.M.	1.044 "	1.598 "	3.236 "	2.436 "	
3/30 11 : 00 A.M.	1.478 "	2.124 "	4.048 "	3.180 "	
4/12 10 : 00 A.M.	—	2.700 "	5.184 "	4.098 "	



## RAPID REFINING OF COPPER WITH A ROTATING CATHODE

BY C. W. BENNETT AND C. O. BROWN

Electrolytic refining of copper, as it is ordinarily done, is carried out with a current density of from 2 to 4 amperes per square decimeter of cathode surface. The amount of copper precipitated in one or two hours by a current of this density is small unless the cathode surface be very large. For the purpose of demonstrating electrolytic refining as a laboratory experiment, the apparatus must be small, the amount of metal deposited must be appreciable, and the time must be limited. It has been shown previously<sup>1</sup> that if the cathode be rotated rapidly, the current density can be increased greatly, current densities up to about 425 amperes per square decimeter having been used. With a small apparatus using current densities of this size, sufficient amounts of copper for demonstration purposes can be deposited in a short time, and appreciable amounts of the impurities may also be obtained as slimes. It was thought advisable, therefore, to make a few tests on the rapid refining of copper to show that it could be done, and also with the idea of using it as a laboratory experiment. These experiments, of course, have very little practical value, and serve only to show that the same conditions obtain in rapid refining as in the commercial refining. They also give another instance of the rapidity of electrochemical work when the solution is stirred vigorously.

The conditions of these experiments, with the exception of the anodes, were practically the same as those obtaining in the previous work on this subject.<sup>2</sup> For this work, however, it was decided to design a more compact apparatus than that previously used. The apparatus as actually used will be de-

<sup>1</sup> Trans. Am. Electrochem. Soc., 21, 253, 268 (1912); Jour. Phys. Chem., 16, 310 (1912).

<sup>2</sup> Trans. Am. Electrochem. Soc., 21, 253 (1912); Jour. Phys. Chem., 16, 294 (1912); 17, 373 (1913).

scribed in some detail. The assembly drawing of the apparatus is shown in Fig. 1. The mechanical details, should any one desire to build the cathode, are shown in Figs. 2 and 3.<sup>1</sup> Upon the base of a one-half horse power direct current motor was mounted a face plate through which the shaft of the motor projected. Upon the shaft of the motor was mounted directly a wheel which has a worm gear cut on it. This worm wheel actuates a worm gear which was cut on the shaft, which was mounted vertically. This shaft operates in three bearings, two at the top and one at the bottom. The worm wheel turns clockwise, so that the shaft thrusts upwards. There is, therefore, a thrust bearing at the top, and also a radial bearing. The bearings are held at the top and bottom in iron cups, which in turn are held in steel rings, the steel rings being fastened to arms, the arms being fastened to the face plate. In this way, as can be seen by reference to the assembly drawing, adjustments of the bearing may be had in all directions. A flexible joint is obtained so that the bearing adjusts itself automatically. As in the cathodes used previously, the shaft projects at the bottom where it is threaded, and screws into a brass connector. The bottom end of this connector is drilled to receive an aluminum pipe, and the aluminum pipe used is  $1\frac{1}{16}$  inches outside diameter. This is held in the connector by set screws. The current is led away from the cathode at the connector by means of a carbon brush fastened with screws to a copper strip, which in turn is fastened to the base of the motor as shown. The pressure of this brush is adjusted by means of a spring. The motor operates at speeds up to 2200, so that the cathode with a  $2\frac{1}{2} : 1$  gear may be run at practically any speed up to 5500 r. p. m. The power required to turn the cathode has not been measured. It is, however, less than  $\frac{1}{2}$  horse power, and will depend, of course, upon the amount of metal on the cathode. In these experiments the cathode extends into the

---

<sup>1</sup> The cost of this apparatus should not be greater than eighty to ninety dollars.

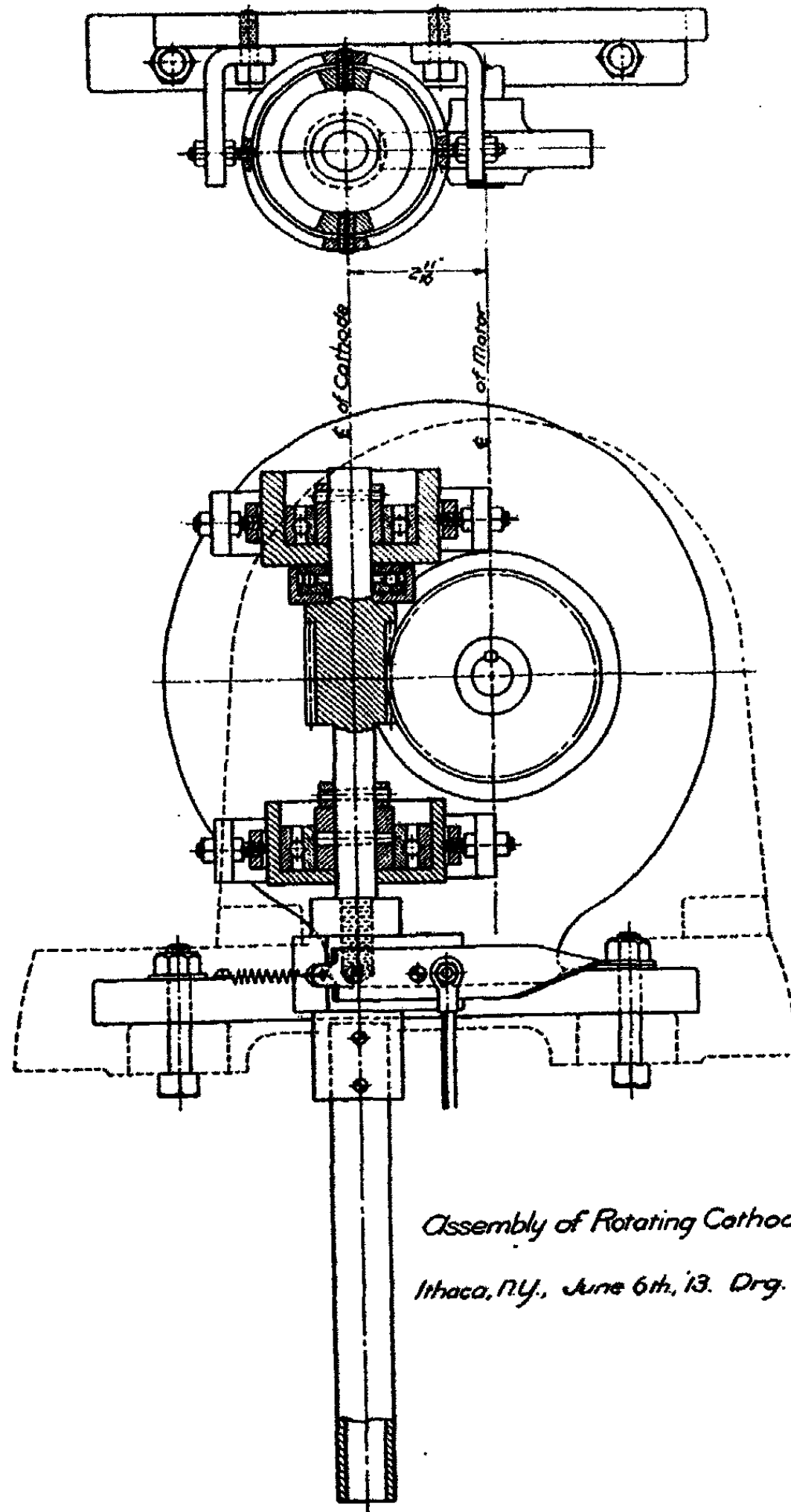

Assembly of Rotating Cathode.

Ithaca, N.Y., June 6th, 13. Drg. 1.

Fig. 1

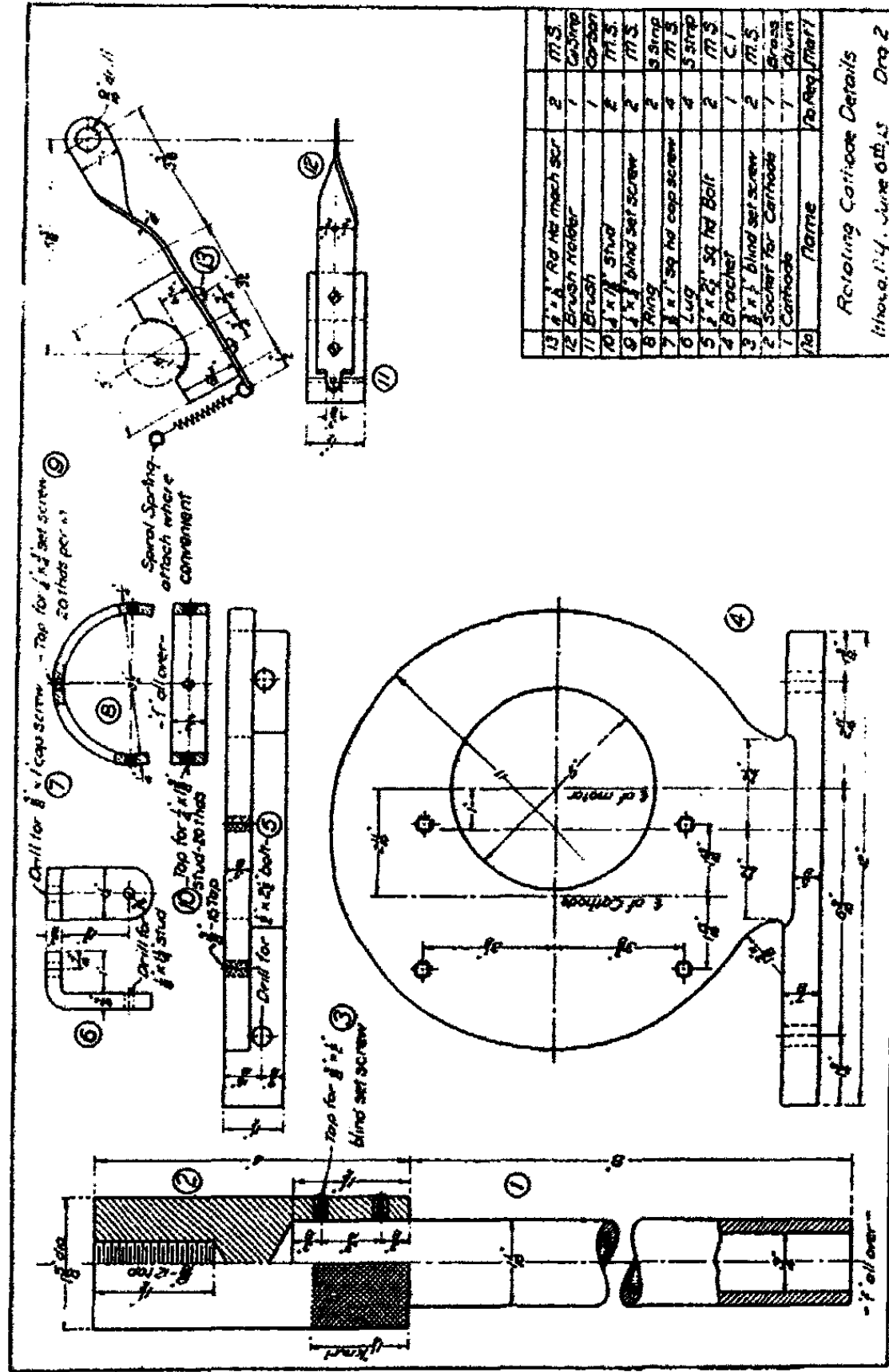

Fig. 2

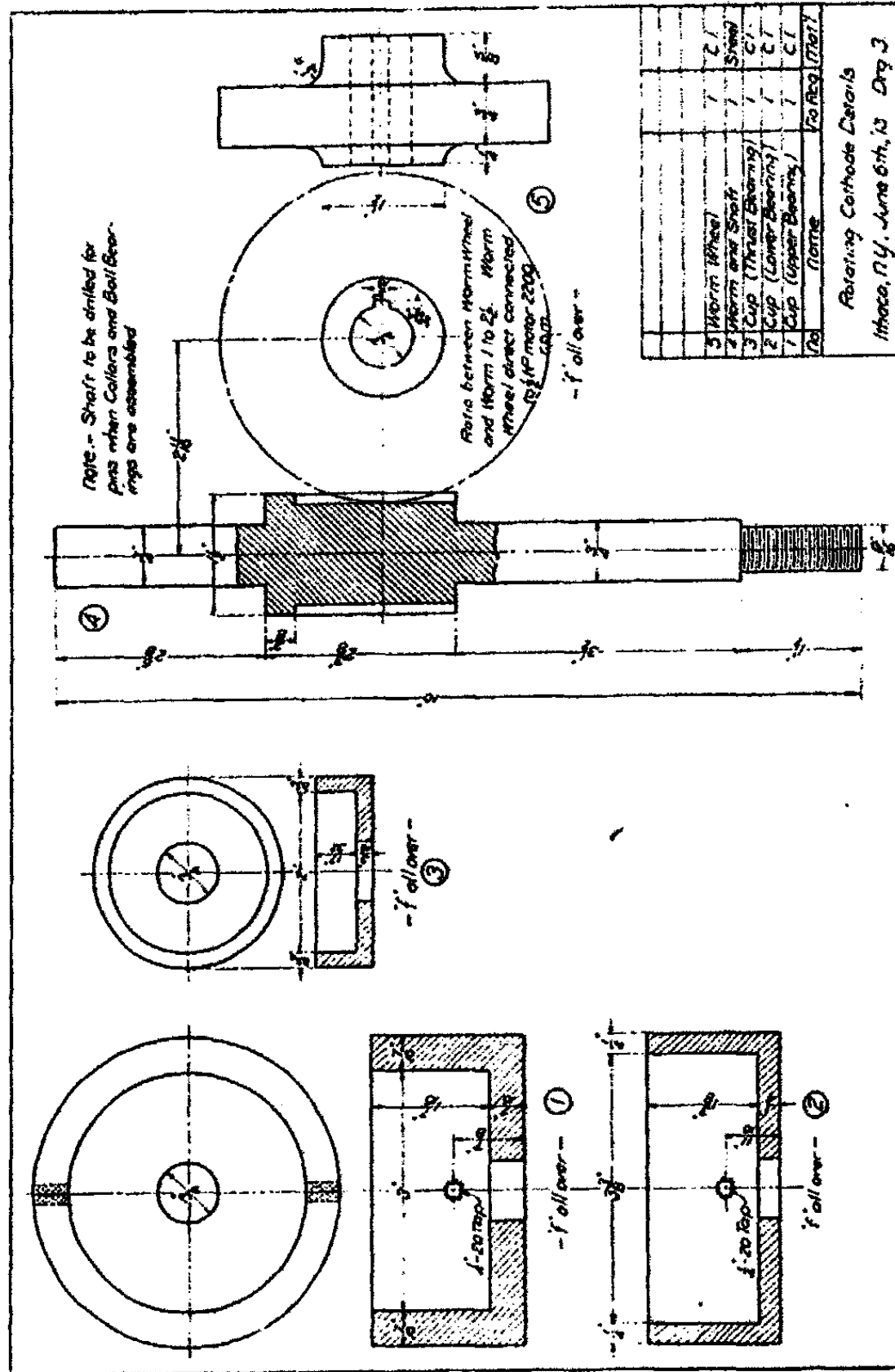

FIG. 3

solution about 12.5 cm, giving a cathode surface of about one square decimeter. If 70 amperes per square decimeter be used, which is a low current density for the rotating cathode, in one hour and a half, approximately 125 grams of copper will be deposited upon the cathode, as used. This gives sufficient copper to show that the metal has been refined, and if the impurities in the anodes be present in high enough concentrations, sufficient slimes will be obtained to show tests for the several impurities.

In order to try out the method, it was decided to use anodes containing silver as the only impurity. The first anode studied was, therefore, made up to contain approximately 1 percent of silver. This amount of silver was added so that within the time set for the experiment, sufficient metal could be obtained to make a silver bead, thus doing away with the danger of disappointing the student by his not being able to obtain appreciable amounts of the impurity. If the process works efficiently, approximately 1.2 grams of silver should be obtained as slimes, in one and one-half hour's run. In the other anodes studied the metals were added in the proportion to make 1 percent. There is practically no loss in casting with any of the metals, save zinc. About 5 percent extra metal should be added in the latter case. Two anodes of each composition were cast, and it may be said that the anodes should be poured under conditions such that smooth solid castings are obtained. If the metal is porous, the slimes are hard to remove.

The first test was on copper containing 1 percent silver. The anodes were connected in multiple, one on each side of the cathode. The current used was 65 amperes and the run was short. The metal deposited was tested and, as was anticipated, was found to contain silver. On account of the rapid rotation and vigorous stirring the slimes of course do not stick to the anode, but are diffused mechanically throughout the solution and are therefore occluded in the deposit mechanically. Diaphragms, consisting of heavy unbleached cotton cloth, were then prepared. These were made by fold-

ing the cloth and sewing it so as to form bags which fit closely to the anodes themselves. The solution used, as in the previous work, was 12 percent copper sulphate with 15 percent sulphuric acid. The cloth was found to stand up well for several days, if necessary, in this solution. The next run with the anodes enclosed in the cloth bags was made under the same conditions. The current was 65 amperes, and the run lasted a little more than an hour, 90 grams of copper being deposited. The voltage drop across the cell was 5 volts. The deposited copper in this case was pure and gave no tests for silver. The slimes were recovered by burning the diaphragms and treating the ashes with nitric acid, filtering and depositing the silver as chloride and reducing, finally obtaining the silver as a bead before the blowpipe, or by depositing electrolytically from the nitrate solution. A good bead of silver was obtained, wholly sufficient for demonstration purposes.

It has been stated by Kiliani<sup>1</sup> that the silver present as impurity in copper anodes goes into solution if a neutral copper sulphate solution is used as electrolyte. The reason for this is not at all evident. It was thought that under the conditions of this experiment a large amount of silver could be obtained in the electrolyte in a short time, since larger currents per unit volume of solution were passed. A run was therefore made, using an anode containing silver in a copper sulphate solution without the addition of acid. A run was also made on a copper sulphate solution, to which ammonium hydroxide was added until it was neutral to litmus paper. After running for a considerable length of time in both cases, the solutions and the deposited copper were tested for silver. No silver could be obtained in either the solution or the deposited copper, so that there is some doubt as to the validity of the statement referred to above.

The second anode studied consisted of approximately the following composition :

---

<sup>1</sup> Kiliani, "Borchers, Electric Smelting and Refining," *Loc. cit.*

copper	97 percent
silver	1 percent
arsenic	1 percent
bismuth	1 percent

The current and voltage were the same as in the preceding experiment, the electrolysis being run for about one hour and three-quarters. In all of these experiments the speed of rotation was between 5500 and 6000 r. p. m. 125 grams of copper was obtained in this case. The deposit was excellent in appearance, and showed only a trace of arsenic by the Marsh test. No silver and no bismuth could be detected in the metal. Slimes were examined, as was previously done, by burning the diaphragms and depositing the metals. Tests for bismuth and arsenic were given and the silver bead was obtained as before.

The last anode studied contained representatives of all the impurities found in commercial anodes, although present in larger quantities. Since this anode was intended to contain all the metals for demonstration purposes, a quantitative analysis of it was made. The analysis is difficult and not essential.

Unless quantitative results are desired it is sufficient to add all of the metals in the proportions desired with the exception of zinc. Five percent of this metal should be added in excess. For those who wish to make the analyses the following references may be of interest.<sup>1</sup> The anode was found to have the following composition:

---

<sup>1</sup> Jour. Am. Chem. Soc., 16, 185 (1894); 17, 714 (1895); 19, 24 (1897); 22, 292 (1900); 24, 699, 1082 (1902); 27, 313 (1905); 29, 607 (1907); Zeit. anal. Chem., 46, 29 (1907).



Metal	Percent
Copper	91.00
Silver	1.09
Lead	1.16
Iron	1.10
Nickel	1.14
Bismuth	1.15
Arsenic	1.20
Zinc	1.17
Carbon	0.70
Total,	99.71

The runs on this anode were quite as successful as the previous ones, the conditions of the runs being the same: current, 65 amperes; voltage, 5 volts; time, about 1.75 hours; copper deposited, about 130 grams. The deposit was found to be quite up to the standard of average electrolytic copper. The impurities in this anode, silver, lead, bismuth, and arsenic, were found in the slimes. Qualitative separations were made of the metals found here and the usual silver bead obtained at the end of the run. Tests for iron, nickel, and zinc were obtained in the solution, although it takes more care to detect these metals in the solution without concentration, and the test is not so satisfactory as in the case of the slimes. No quantitative tests were made on the deposited copper, but qualitative tests indicate that it would require very accurate analyses to detect any variation from 100 percent copper. Quantitative tests were not made on the slimes to determine how efficient the recovery was. Some of the slimes, of course, stick to the anodes and are therefore hard to obtain, so that the quantitative tests would not have meant anything had they been run.

In conclusion, it may be said, that electrolytic copper refining may be demonstrated in the course of an hour if a rotating cathode be used. The anodes may contain impurities usually found in commercial anodes, the demonstration being more striking if the impurities are present in

amounts approximating 1 percent each. The anodes should be contained in a diaphragm and the slimes may be removed partially with the diaphragm and the remainder by means of a stiff brush, and water from a wash bottle. The deposited copper may be stripped off and sampled if aluminum cathodes are used.

Arsenic shows the largest tendency to contaminate the refined copper. It requires, however, the delicate Marsh test to detect this metal.

The statement that silver dissolves in neutral copper sulphate solution is probably an error.

*Electrochemical Laboratory  
Cornell University*

## EFFECT OF LIGHT ON DECOMPOSITION VOLTAGE

BY ALAN LEIGHTON

The following experiments were undertaken to determine the effect of light on the decomposition voltage of copper sulphate solutions. A mercury vapor lamp, enclosed in a tube, was placed in the copper sulphate solution between the electrodes. By means of a rubber cloth, it was possible to shield either electrode from the light or both electrodes if necessary. An ammeter was placed in series with the electrolytic cell and a voltmeter was connected to the terminals of the cell. This arrangement<sup>1</sup> does not give the true decomposition voltage because the voltage drop through the solution is included. Since the electrodes were always kept in the same position, the error is practically constant throughout each series and is negligible, because we were interested in the change of voltage produced by turning on the light. From the experiments of others it seems justifiable to assume that light causes no marked change in the conductance of a copper sulphate solution except in so far as the heat from the lamp may change the temperature of the solution.

Owing to the relatively high resistance of the solution it was not found practicable to determine the decomposition voltages by plotting voltages against current. The error due to the personal equation is much too large. It was found better to keep the voltage constant for a while and then to determine by inspection whether copper had or had not been precipitated at the cathode.

In Table I are given data for the copper sulphate solution in the dark. Graphite electrodes were used, which were coated with paraffin except over a small rectangular space.

The apparent decomposition voltage is very close to 1.40 volts because a slight deposit of copper is obtained in one

<sup>1</sup> The current flowing through the voltmeter also flows through the ammeter.

experiment and none in the other. At 1.50 volts we are distinctly above the value, at 1.30 volts distinctly below it.

TABLE I

100 grams  $\text{CuSO}_4 \cdot 5\text{H}_2\text{O}$  per liter; graphite electrodes. Surface of electrode = 1 sq. inch. Distance between electrodes = 2.75 inches. Time of run = 25 minutes

Volts	1.40	1.50	1.40	1.30
Amperes	0.010	0.010	0.010	0.010
Deposit	No	Yes	Slight	No
Temperature	23°	23°	23°	23°

A run was next made at 1.3 volts with both electrodes exposed to light. A slight deposit of copper was obtained. When the anode was screened from light, a slight deposit was also obtained. Much to our surprise, a distinctly heavier deposit was obtained when the cathode was shaded and the anode was exposed to light.

Owing to the difficulty in determining the presence of slight deposits of copper on the graphite cathode, it was thought advisable to substitute a platinum cathode of the same effective area as the graphite one, the back and all but about one square inch of the face being coated with paraffin. The graphite anode was retained.

In Table II are given data obtained under the new conditions. Under the heading "Light," C means that the cathode was illuminated, A that the anode was illuminated, and A + C that both were illuminated.

An examination of Table II shows that we may ignore the temperature fluctuations so far as these measurements are concerned. The only place where there is the slightest trace of a discrepancy is that, at 1.3 volts with the cathode illuminated, we get no deposit at 25° and a very slight one at 20°. A precisely similar result was obtained in Table I when there was no change in temperature.

If we study the experiments without light we find that there was no deposit of copper at 1.0 volt and that copper was deposited at 1.2 volts, at 1.3 volts and at 2.0 volts. The

decomposition voltage, as thus measured, is therefore at least as low as 1.2 volts. Later experiments indicate that it is probably 1.1 volts. Either figure is distinctly lower than the value obtained with a graphite cathode. No experiments have been made to determine to what this difference is due.

TABLE II

100 grams  $\text{CuSO}_4 \cdot 5\text{H}_2\text{O}$  per liter; graphite anode and platinum cathode. Surface of electrode = 1 sq. inch. Distance between electrodes = 2.75 inches. Time of run = 15 minutes

Volts	Amps.	Deposit	Light	Temp.
1.0	0.008	No	No	28°
1.3	0.010	Yes	No	28
1.0	0.008	Yes	A	28
1.0	0.008	No	No	20.5
1.0	0.008	Yes	A	28
1.0	0.008	Yes	A	25
1.0	0.008	No	No	25
1.0	0.008	No	C	27
1.0	0.008	No	A + C	28
2.0	0.040	Yes	No	19
2.0	0.040	Yes	C	22
1.5	0.015	Yes	C	22.5
1.3	0.010	No	C	28
1.3	0.010	Yes	No	25
1.4	0.012	Yes	C	26
1.0	0.008	Yes	A	27
1.0	0.008	Yes	A	27
1.2	0.008	Yes	No	27
1.3	0.010	Slight	C	20

When the anode alone is illuminated, we get a deposit of copper at 1.0 volt and at all higher voltages. Therefore we conclude that exposing a graphite anode to the light of a mercury vapor lamp lowers the decomposition voltage of a copper sulphate solution.

When the cathode is illuminated, there is no deposit at 1.0 volt and none, or only a very slight one, at 1.3 volts. At 1.4 volts we get a distinct deposit of copper. Exposure of a platinum cathode to light therefore increases the decomposition

voltage of a copper sulphate solution. A necessary consequence of these two experiments is that a higher voltage will be necessary to deposit copper when both electrodes are illuminated than when the anode alone is. This has been confirmed experimentally, for no copper was obtained at 1.0 volt when both electrodes were exposed to light.

The results given in Table II are entirely consistent; but some later experiments were quite discordant, as may be seen from Table III.

TABLE III

100 grams  $\text{CuSO}_4 \cdot 5\text{H}_2\text{O}$  per liter; graphite anode and platinum cathode. Surface of electrode = 1 sq. inch. Distance between electrodes = 2.75 inches. Time of run = 15 minutes

Volts	Amps.	Deposit	Light	Temp.
1.0	0.008	No	No	22°
1.0	0.008	Slight	A	22
1.0	0.008	Slight	A	22
1.1	0.008	No <sup>1</sup>	C	22
0.8	0.008	No	No	23
0.8	0.008	No	A	23
1.0	0.008	No	A	23
1.1	0.008	Yes	A	23
1.0	0.008	Yes	No	25
0.9	0.008	Yes	No	25

The last two experiments in Table II are quite abnormal because copper was deposited in the dark at 1.0 volt and at 0.9 volt. Three days later copper could be deposited at 0.7 volt without the aid of light. It was thought that perhaps copper had been deposited on the graphite electrode during the time which had elapsed since the last run and that this might be due to the action of sunlight because the apparatus had been moved from a relatively dark corner to a place near the window. This did not seem impossible because it is known

<sup>1</sup> In this experiment no copper was deposited on the illuminated face of the cathode but some copper was deposited on the shaded back of the cathode on a spot where the paraffin had been knocked off accidentally.

that charcoal precipitates metallic silver from a silver nitrate solution in the dark.

If copper, or some other depolarizer, is formed in the pores of the graphite anode, it ought to be possible to remove this unknown substance by anodic polarization of the graphite. In other words, a moderate current should "flush out" the graphite, after which no copper should be obtained at 1.0 volt. To test this hypothesis, the graphite was exposed to light for twenty minutes. The light was then turned off and a deposit of copper was obtained at 0.8 volt. Owing to press of other work, no further experiments were made on this day. Two days later copper could be obtained at 0.95 volt with no light. The anode was "flushed out" and then tested. At 0.9 volt no copper was obtained, but a slight deposit was obtained at 1.0 volt. The circuit was broken and the graphite anode exposed to light for twenty minutes. The light was cut off and the electrode tested at once. Copper was deposited at a voltage of 0.42 volt. The anode was flushed out and no copper was obtained at 0.9 volt.

It is thus evident that some depolarizer is formed in or on the graphite slab and that this depolarizer can be removed by electrolysis. Experiments were now made to determine whether light was essential to this reaction. It was found that similar results could be obtained in the dark, provided the graphite was left long enough in the solution. Light is therefore not necessary to this reaction although it accelerates it.

In none of the experiments made as yet, has the decomposition voltage gone below 0.4 volt, which would rather imply that metallic copper is not formed. It is more probable that a reduction takes place to a cuprous salt. This should be tested with charcoal rather than with graphite, so as to get the maximum effect. It has not been possible to do this as yet.

Since the graphite anode introduced these special variations, a few experiments were made with platinum anode and cathode.

The data are given in Table IV.

TABLE IV

Copper sulphate solution; platinum electrodes. Surface of electrodes = 1 sq. inch. Distance between electrodes = 2.75 inches. Time of run = 15 minutes

Volts	Deposit	Light	Volts	Deposit	Light
1.42	Yes	No	1.36	Yes	No
1.40	Yes	No	1.38	No	C
1.38	Yes	No	1.38	Slight	C
1.36	Yes	No	1.38	Slight	C
1.34	Yes	No	1.32	No	A
1.32	No	No	1.32	No	A
1.36	No	C	1.34	Yes	A

From Table IV we see that copper is deposited in the dark at a minimum voltage of 1.34 volt. Illuminating the platinum anode has no measurable effect, while illuminating the cathode increases the necessary minimum voltage to 1.38 volt. This result was tested qualitatively in different ways. On removing the paraffin from the back of the cathode and regulating the voltage suitably, it was possible to make copper precipitate on the shaded back of the cathode and not on the illuminated front, the difference in voltage more than compensating for the extra drop of potential through the solution.<sup>1</sup> In another set of experiments, the back of the platinum cathode was paraffined as before and one-half the front was shaded. Copper was deposited on the shaded portion and not on the half exposed to light. The screen was then moved so as to reverse the illumination, whereupon copper dissolved from the portion which had been shaded and was now exposed to light, while copper precipitated on the other half of the cathode which was now shaded. These experiments seem to eliminate any possibility of the effect being due to heating or anything of that sort.

Since a copper sulphate solution absorbs a good deal of light, the light which is absorbed must make the solution less stable and should therefore decrease the decomposition voltage.

<sup>1</sup> An accidental case of this sort was given in Table III.



This was the result which these experiments were expected to show. As a matter of fact, the reverse is true, so some factor has been overlooked in the deduction. The forgotten factor is evidently the electrode. It is only the solution in immediate contact with the electrode which counts, so far as the electromotive force is concerned. In these experiments, both the solution and the platinum electrode are exposed to light. The light causes the solution to become less stable and consequently decreases the decomposition voltage. The light also causes the precipitated copper to be less stable and consequently increases the decomposition voltage. What we measure is the difference between these two. Since the light, which is effective in tending to decompose the solution, is most intense close to the lamp and least intense at the electrode, the conditions are ideally bad for getting a maximum effect with the solution. Since copper absorbs light more completely than the solution, the chances are in favor of the effect of light on copper being greater than the effect of light on the solution. It is probable that one could vary these relative effects by using suitable monochromatic light and it is also possible that the mercury lamp is not the best source of light for these particular experiments. It was used because it was the one available source of light which could be placed easily in the solution between the electrodes.

One experiment was tried with a graphite anode and a platinum cathode, using an electric arc so placed that the light was nearly parallel to the surface of the electrodes, the idea being that the light would only graze the surface of the electrode and that consequently one would get the maximum effect due to the solution and the minimum effect due to the electrode. This experiment seemed to give a slight positive result, some copper being obtained at 1.0 volt. It is a question whether this was a real effect of light or whether it was due to the graphite anode. The experiment would have to be repeated a number of times with platinum electrodes before I should be willing to be positive as to the results.

The fact that what one usually measures is the difference

of the effect of light on the solution and on the electrode, may perhaps account for the surprisingly small electromotive forces observed by others in special cases.

The general results of this paper are:

1. The decomposition voltage of a copper sulphate solution between platinum electrodes is not affected appreciably when the anode is illuminated by a mercury lamp.
2. The decomposition voltage of a copper sulphate solution between platinum electrodes is increased when the cathode is illuminated by a mercury vapor lamp.
3. The light tends to make the solution and the deposited copper less stable. The latter effect is the greater under the conditions of the experiment.
4. It is possible to regulate the voltage so as to make copper precipitate on the shaded portion of the platinum cathode and not on the illuminated portion.
5. Graphite adsorbs something from a copper sulphate solution, presumably a cuprous salt, which acts as an anodic depolarizer and can be removed by electrolytic oxidation. The reaction is accelerated by light.
6. Owing to this adsorption the decomposition voltage for a copper sulphate solution with a graphite anode and a platinum cathode can be brought down temporarily to about 0.4 volt.

This work was suggested by Professor Bancroft and has been carried on under his supervision.

*Cornell University*

## ACTION OF CALCIUM CHLORIDE ON ROADS

BY F. R. NEWMAN

It is a fairly common practice nowadays to spread calcium chloride over the roads as a means of preventing dust and it is often claimed that the calcium chloride will not wash out of the surface of the road. These two statements are difficult to reconcile. Calcium chloride is an extremely deliquescent salt and, therefore, condenses moisture from the air when the concentration is well below the normal dew-point. The formation of a film of solution prevents the formation of dust. The dissolved calcium chloride should, however, wash out of the soil. We can account for the alleged fact that calcium chloride does not wash out of the soil by assuming that the salt is adsorbed by the soil; but, the more strongly adsorbed the calcium chloride is, the less hygroscopic it will be and, therefore, the less effective in laying the dust. It seemed desirable to find out what the facts were.

Experiments were made with a pure sand and with the top dressing of a macadamized road which had been treated with calcium chloride during the summer. The sand was bought from the Carborundum Co. and is the sand used in making carborundum. Previous analysis in the Cornell laboratory had shown that this sand contains about 99.6 percent  $\text{SiO}_2$ . The sand was dried for an hour at  $140^\circ$  and was found to be fairly uniform in size, 20 percent passing a 60-mesh sieve, ninety percent passing a 40-mesh sieve, and 100 percent passing a 20-mesh one.

The fusing mixture, potassium nitrate and sodium carbonate, gave no test for chlorides, and the nitric acid (6N) was also free from chloride. To determine the chloride content of the sand before and after treatment with calcium chloride, approximately one gram of sand was mixed with eight grams of fusing mixture and the whole decomposed by heating with a blast lamp in a platinum crucible until quiet fusion was effected. The crucible was then cooled, a little water

was added and the melt was detached by gentle heating. The contents of the crucible were poured into a porcelain dish, and treated with water and with nitric acid. The gelatinous precipitate was filtered off and the filtrate tested gravimetrically with silver nitrate. No chloride was obtained from the pure sand.

Thirty grams of calcium chloride and 40 cc water were added to 100 grams sand, the whole was stirred vigorously and allowed to stand for twenty-four hours, a pasty mass being formed with no supernatant liquid. Approximately ten-gram portions of the mass were placed in small beakers, 25 cc water added and the whole stirred vigorously. After settling, about 25 cc solution were decanted and the operation repeated until the wash water gave no test for chloride. The sixth wash water gave only a slight turbidity and the eighth was free from chloride.

To the third wash water 10 cc nitric acid were added and the solution made up to 100 cc. Silver nitrate was added drop by drop, the solution being shaken constantly. After complete precipitation the silver chloride was filtered through a Gooch crucible and the excess of silver nitrate washed out with dilute nitric acid. The crucible and precipitate were dried in an air bath at  $110^{\circ}$  for two hours and were left to cool in a desiccator. The third wash water from one of the small beakers contained about 30 milligrams  $\text{CaCl}_2$ . Practically all of the calcium chloride is, therefore, removed in the first two washings and all of it is removed in seven washings.

After the eighth washing the sand was tested for chloride by fusion, etc., as previously described. Duplicate experiments gave 5.5 milligrams  $\text{CaCl}_2$  per gram of sand or 0.55 gram  $\text{CaCl}_2$  per 100 grams sand.

These experiments show that calcium chloride is adsorbed but slightly by sand and that calcium chloride washes out of the sand very rapidly.

In another experiment 30 grams sand and 9 grams  $\text{CaCl}_2$  were placed in a small beaker and allowed to stand in a desiccator over water for nineteen days. At the end of that time

sufficient water had condensed in the beaker, and analyses were made as before. The third wash water contained about 10 milligrams  $\text{CaCl}_2$ , referred to approximately ten-gram portions. The sixth washing showed a slight turbidity, but the ninth gave no test for chloride. The amount of  $\text{CaCl}_2$  retained by the sand after the ninth washing proved to be 145 milligrams per gram sand. This is much more than was obtained in the previous run. It is quite possible that this extra amount was adsorbed during the nineteen days in which the sand and calcium chloride were in contact; but the matter did not seem to warrant further experiments at this time.

A quantity of top dressing was taken from a macadam road between Sibley College and Franklin Hall in Ithaca. This road had been treated with calcium chloride during the summer. The earth was dried for several hours at  $140^\circ$ , was pulverized, and passed through a 100-mesh sieve. The chlorine content was determined as in the previous experiments and was calculated as calcium chloride so as to be on the safe side. The amount of  $\text{CaCl}_2$ , as thus tabulated, was 20 milligrams per gram  $\text{CaCl}_2$ . A mixture was made up of 100 grams earth, 30 grams  $\text{CaCl}_2$ , and 55 cc water. After standing twenty-four hours, the mixture was divided into approximately ten-gram lots and washed as before. The third wash water gave 180 milligrams  $\text{CaCl}_2$  and the sixth, 6 milligrams  $\text{CaCl}_2$ . A slight cloudiness was obtained with the ninth and twelfth washings while the fourteenth gave no test. The chlorine content of the earth after the fourteenth washing was about 5 milligrams per gram earth.

It is thus clear that the top dressing does not adsorb calcium chloride appreciably differently from pure sand. The relatively high amount of calcium chloride in the original top dressing shows that the washing by the rain was not very thorough during the summer of 1911. While the calcium chloride does not wash out of the top dressing as fast as it does out of sand, this difference is probably due entirely to the greater fineness of the top dressing.

When stood over, water sand containing a little calcium

chloride condenses more water than sand containing none. The original top dressing takes up more water and takes it up faster than top dressing which has been treated with calcium chloride, washed thoroughly and dried. The reason for this is that the original top dressing contains more calcium chloride than the other. Some experiments were made with a washed and air-dried top dressing using different strengths of sulphuric acid in the desiccator. With 75 percent  $H_2SO_4$  the soil lost moisture; with 25 percent  $H_2SO_4$  the soil took up water from the acid; with 50 percent  $H_2SO_4$  some moisture was taken up from the acid but we were evidently not far from the equilibrium mixture. This is in harmony with the known vapor pressures of calcium chloride and of sulphuric acid. It did not seem worth while to make more accurate measurements, though this could easily be done if anybody so wished.

The general conclusions of this paper are:

1. The usefulness of calcium chloride in laying dust depends upon the presence of free calcium chloride in the soil.
2. Very little calcium chloride is adsorbed by the soil and consequently the salt can be washed out readily.
3. The time during which calcium chloride remains effective in laying the dust depends on the amount of rain and on the readiness with which the water drains off.
4. There is no basis for the claim, sometimes made, that two treatments with calcium chloride will keep a road in good shape all summer. On the other hand, calcium chloride does not wash out of a road as rapidly as one might at first expect.

This investigation was suggested by Professor Bancroft and has been carried on under his supervision.

*Cornell University*  
*November, 1911*

## NEW BOOKS

**The Fitness of the Environment.** By Lawrence J. Henderson. 19 X 14 cm; pp. v + 317. New York: The Macmillan Co., 1913. Price: \$1.50—For years we have been familiar with the idea that organisms gradually adapt themselves to the environment. The author's contention is that the actual environment is the one best fitted to the development of life, in other words, that the world as we know it is the best of all possible worlds. It is easy to see that water, oxygen and carbon dioxide are essential for organisms as we know them; but it may be merely lack of imagination which prevents our seeing the possibilities under other circumstances. Since there are anaerobic bacteria there seems to be no reason why fishes might not have developed which would flourish in liquid ammonia in case the rivers and oceans contained ammonia instead of water. The burden of proof, however, is on the man who claims that one might have complex organic substances based on some other element than carbon. So far as our present knowledge of chemistry goes, carbon stands alone in the number and complexity of compounds that can be formed. There may be a similar chemistry of silicon or of nitrogen at the temperature of liquid ammonia but we have no proof of this as yet.

In the preface the author speaks of the reciprocal character of Darwinian fitness, meaning that we have environmental fitness as well as fitness of the organisms to the environment. This may be criticized as a matter of expression, because there has been no adaptation of the environment to the organisms. What the author means is that the environment is admirably fitted to the development of the organisms which have adapted themselves to it.

The author has written a very readable book, and he has only rarely let his thesis run away with him badly. One might take exception to the implication, p. 241, that magnesium salts in chlorophyll act like magnesium in Grignard's reaction. The quotations from pp. 55, 67, 184 and 138 will give an idea of the style of the book.

"Even at the earliest period in the evolution of a typical star there appears to be a progressive variation in chemical composition from center to periphery. Theoretically it seems inevitable that the heaviest elements should be concentrated in the interior and that those of lowest atomic weight should be present in greatest amount near the surface. Actually, as above stated, spectroscopic investigation fully confirms this view. Thus the spectra of typical hot stars show that hydrogen is an invariable constituent of their superficial parts. Indeed the universal presence of hydrogen under such circumstances is undoubtedly one of the most clearly established facts of stellar astronomy. As stars cool and become red the spectral changes quite as unmistakably point to the presence of carbon. Accordingly we possess the best of evidence and the best of reasons for the belief that large quantities of hydrogen and carbon must exist at or near the surface when a crust forms upon a cooling star."

"The very constant temperature of the ocean is a most important factor in the economy of nature. It constitutes, for example, a vital regulation of the environment of a large proportion of all the living organisms of the world, and

it has many other important 'functions.' This constancy of temperature is in large part due to the magnitude of the specific heat of water. Other things being equal, the greater the specific heat of water, the more constant must be the temperature of the ocean. If, then, the specific heat of water, as is actually the case, be nearly or quite a maximum among all specific heats, it follows that the fitness of water in this respect is nearly maximal.

"Again, the ocean contains an astonishing variety of substances in solution, and they are present often in large quantities. In this manner a very great supply of food in very great variety is offered marine organisms. Of course such richness of the environment is an exceedingly favorable circumstance for the organism, and it is due principally to the ability of water to dissolve a multitude of things in large quantities. It is not to be supposed that the substances present in sea water are all of use to every organism. This need not be the case at all; but a variety of supplies which may be adapted to special requirements as they arise, here iodine, there copper, for instance, is a very genuine advantage. Further, the vast utility of the solvent action of water in blood, lymph, and all the body fluids is too patent to call for comment. If, now, it can be shown that the efficiency of water is nearly or quite a maximum, as it really is, among all known solvents, then it must be evident that in another respect the fitness of water is nearly or quite maximal.

"Again, the amount of energy that is required to tear apart molecules of water, and to liberate hydrogen and oxygen, is very great indeed, and when hydrogen and oxygen recombine to form water, this energy must reappear—under ordinary circumstances as heat. This fact, too, is very favorable for the organism, because almost all compounds which contain hydrogen yield a great deal of energy when they are burned; they are, in short, great reservoirs of energy which can be tapped in the process of metabolism. If, therefore, the heat of combustion of hydrogen be nearly or quite a maximum, as it is, among all substances, it is clear that water is again, in another respect, most wonderfully fitted for life.

"Finally, if it be true, and such is the case, that very few of the substances which share the fitness of water in one of these characteristics also share or approach its fitness in either of the others, and that none possess all of these qualifications in a degree that merits consideration, it must, I conceive, be admitted that so far as the investigation has proceeded water is the only possible substance."

"Perhaps the first desideratum in an environment as a source of food is mobility. Any organism which, like the lilies of the field, need not toil for its nourishment, is in most favorable conditions, and such conditions are the principal cause of the enormous wealth of vegetation upon the earth. Now the ocean, apart from the flora and fauna which inhabit it, is perfectly homogeneous; hence its mobility brings to an organism all that it has to offer, and even sweeps along organic nourishment as well. In the ocean not only plants but many animals may remain motionless and, like the oyster, await the food that will surely be borne to them; or they may float freely, relying on the mixing of the water to bring them into contact with their food.

"After mobility, richness and variety of environment are important. It



is certainly impossible to imagine a medium more rich and varied in elementary constituents than sea water, unless it be sea water with still other substances added to it. But, in the first place, there are few absent elements which might be added, and, in the second place, the addition of other substances would be likely to cause the escape of bodies which are present. At all events, the ocean is certainly more favorable in these three respects than if it were anything else that could occur in the course of nature. Almost ideally mobile, rich and varied, the sea is an almost perfect source of supply for a complex mechanism. To be sure there are great difficulties in extracting its constituents from sea water, and the efficiency of physiological processes is a factor essential to their utilization, but at least there stand materials ready for the mechanism which can employ them."

"Accordingly, if water be the first primary constituent of the environment, carbonic acid is inevitably the second—because of its solubility possessing an equal mobility with water, because of the reservoir of the atmosphere never to be depleted by chemical action in the oceans, lakes, and streams. In truth, so close is the association between these two substances that it is scarcely correct logically to separate them at all; together they make up the real environment and they never part company. Carbonic acid thus possesses the first great qualification of a food; its occurrence is universal and its mobility a maximum. This is due to the fact that its absorption coefficient is on the average approximately one, the most favorable value.

"Needless to say the absorption coefficient of carbonic acid is also of great importance in many physiological processes, chiefly perhaps in excretion. In the course of a day a man of average size produces, as a result of his active metabolism, nearly two pounds of carbon dioxide. All this must be rapidly removed from the body. It is difficult to imagine by what elaborate chemical and physical devices the body could rid itself of such enormous quantities of material were it not for the fact, that, in the blood, the acid can circulate partly free, and, in the lungs, by a process which under ordinary circumstances has all the appearances of a simple physical phenomenon, can escape into air which is charged with but little of the gas. Were carbon dioxide not gaseous, its excretion would be the greatest of physiological tasks; were it not freely soluble, a host of the most universal existing physiological processes would be impossible."

*Wilder D. Bancroft*

*Dictionary of Applied Chemistry. Vol. III. By Sir Edward Thorpe. 24 × 18 cm; vii + 789. New York: Longmans, Green & Co., 1913. Price: \$13.50 net.*—The third volume begins with granite and ends with oils. Among the interesting subjects treated in this volume are: granite, graphite, gums and gum resins; gutta serena; helium; honey; hydrazines; hydrogen peroxide; hydrolysis; indamines and indophenols; indigo; ink; iodine; iridium; iron; ivory; ketones; lactic acid; lactones; lakes; lead; leather; linseed oil; liquefaction of gases; liqueurs and cordials; lithium; litmus; logwood; lubricants; madder; magnesium; marble; margarine; matches; mercerizing; mercury; metallography; methyl compounds; milk; molybdenum; naphthalene; nickel; nitrogen; oils.

The volume is well up to the standard set by the preceding ones, the article

on metallography, for instance, being remarkably good. The reviewer sees no reason for not putting "marking inks" under "inks," and he, personally, is sorry not to find "jellies" as a heading. The following paragraphs, pp. 63, 184, 185 and 402, are distinctly suggestive and are quoted for that reason.

"The spectrum of hydrogen consists essentially of four bright lines—one in the red, corresponding with Fraunhofer's dark line C, and one in the greenish blue, coincident with the dark line F. Their wave lengths are (Ångström) C = 6562, F = 4861, blue = 4340, indigo = 4101 in ten-millionths of a millimeter.

"Hydrogen is an inflammable gas, burning in air or oxygen with an extremely hot, almost colorless flame, and producing water. Even with pure hydrogen, however, the centre of the flame is colored green, while the external portions are of violet-blue color. On reducing the pressure, the blue color is transformed to green, and from that successively to yellow, orange and red. Under increased pressure, hydrogen burns with a luminous flame."

"The substance of ivory is permeated by an immense number of fine canals, about  $\frac{1}{1500}$  inch in diameter, and strongly curved, to which are due its fineness of grain and probably much of its elasticity. That obtained from the tusks of *Proboscida* exhibits, on a transverse section, a characteristic pattern of curved decussating lines. The cross-section shows a central spot, the residue of the pulp-centre, surrounded by concentric circular 'contour lines,' due to a number of minute irregular 'interglobular spaces.' These spaces and the canals are probably filled with protoplasmic matter in the living tooth. The exterior of the tooth is covered with cementum usually of a brown color.....

"The tusks [of the elephant] are implanted to the extent of about one-half their length in curved bony sockets which run nearly vertically upwards to the level of the eyes. The part within the socket has a conical centre of pulp by the conversion of which into dentine growth takes place, fresh pulp being formed continually at the base of the tooth. The pulp is not easily injured and sometimes foreign bodies, such as bullets and spear-heads have been found embedded in solid ivory, their presence in the pulp having failed to inhibit its conversion into dentine."

"These minerals [nephrite and jadeite (jade)] have, in common, a white to green (rarely a pale violet) color, with a certain degree of translucency and a greasy appearance on highly polished surfaces. They are remarkable for their extreme toughness (as distinct from hardness), it being very difficult to fracture pebbles by blows from a hammer. This toughness is a result of the peculiar texture of the material: thin sections examined under the microscope show a close, felted aggregate of short, minute fibres."

"A large number of patents have been taken out for 'homogenizing' or 'atomizing' in special machines the mixture of milk and oils and fats [margarine]. The merit claimed for these machines is that the product is more solid and has no 'oily' but 'rather a nut-like' taste. The important demerit of all these apparatus is, however, that the margarine retains more water, and hence the proportion of fat falls below 80 percent. Therefore in those countries where the maximum percentage of 16 percent of water is prescribed by law, the sale of such margarine would meet with difficulties. In order to obviate this draw-

back, and at the same time to dispense with the kneading machines, in which the excess of milk is removed. Schroeder carries out the blending and emulsifying process in three churning machines arranged one above the other and working in conjunction with an 'atomizer.' The temperature in the three churns through which the mixture of fats and milk passed is regulated carefully so that the completely emulsified contents of the lowest churn can be discharged on to a cooled table, where the mass solidified to a thin layer, which is scraped off by a tangentially acting 'doctor' so that the thin solidified film is curled up and discharged into a wagon. The ingredients forming the margarine are mixed in the proportion of 80 parts of fats and oils, 16 parts of milk, and 4 parts of cream, consisting approximately of one-third of butter fat."

*Wilder D. Bancroft*

**An Introduction to the Physics and Chemistry of Colloids.** By *Emil Hatschek*. 19 X 13 cm; pp. 87. Philadelphia: P. Blakiston's Son & Co., 1913. Price: \$1.00.—"The present work is a slightly enlarged reprint of a series of articles published by *The Chemical World*, which in their turn were based on a course of ten lectures delivered at the Sir John Cass Technical Institute to students of very varied attainments and interested in every branch of chemistry and of chemical industry. The book accordingly does not aim at a completeness precluded alike by its compass and the extremely vigorous growth of the subject, but is only intended to introduce readers with a reasonable knowledge of physics and chemistry to the fundamental facts and methods of a branch of physical chemistry, on the importance of which it is hardly necessary to insist."

A rather nice point is to be found on page 6. "We should probably be quite ignorant of the existence of one important element, iodine, and should certainly not be able to use it freely, if it were not for the selective adsorption exerted by a number of seaweeds, as iodine cannot be shown to be present in sea-water by any of the usual tests."

Part of the discussion of viscosity, pp. 21-23, is worth quoting. "As regards colloidal solutions, they divide themselves into two classes, if the increase of viscosity, compared with that of the solvent, or continuous phase is taken as the basis of classification. One class, the metal and sulphide sols in particular, shows a viscosity only very slightly higher than that of water. The other, which comprises principally the organic colloids, such as albumin, gelatine, gum arabic, agar, etc., shows a very marked increase of viscosity, even if the percentage of dissolved matter is small. To explain this difference some of the earlier investigators in this field, more especially Quincke, resorted to reasoning by analogy, based on the known behavior of systems containing the disperse phase in a much coarser form than do the sols. It is a fact familiar to everybody who has stirred up finely divided solid matter, such as precipitate of calcium carbonate or barium sulphate, with water, that even 20 or 30 percent do not offer a very great resistance to stirring, i. e., do not cause a great increase of viscosity. On the other hand, it is equally well known that systems of two liquids insoluble in each other, generally called emulsions, can under certain circumstances show enormous increase in viscosity compared with either phase. Various pharmaceutical preparations coming under this head are familiar to

everyone; extreme cases are represented by some emulsions used as lubricants, and by Pickering's emulsions with 99 percent of oil in 1 percent of soap solution, which could be cut into cubes.

"Applying these considerations to sols, we are led to the conclusion—now generally accepted—that in those which show a low viscosity the disperse phase is present as solid particles, while in the sols with high viscosity the disperse phase is liquid. An albumin sol, for instance, would consist of a dilute solution of albumin, in which are dispersed drops or globules consisting of a much more concentrated solution. This conception is certainly not an easy one, and will receive further discussion when we arrive at the detailed consideration of the class of colloids to which it applies, but it is the only one which explains all their peculiarities. Nor does it rest only on the analogies set forth, but is strongly supported by mathematical investigations, undertaken independently and by entirely different methods, by A. Einstein and by the author during recent years. These show, that the presence of solid particles in a liquid can only raise the viscosity by small amounts simply proportional to the volume of solid matter present; when a few per cent. of—apparently—solid matter like agar raise the viscosity some hundred times, it follows that the disperse phase cannot be solid.

"Systems consisting of solid particles of microscopic size distributed through a liquid are generally called suspensions, while those having two liquid phases are called emulsions."

In the case of Pickering's emulsions the more viscous phase is the external one. An easier—as well as a more satisfactory—way out of the difficulty would be to assume that agar forms the dispersing phase and not the disperse phase.

The experiments of Dreaper and Davis on night blue, p. 81, are also distinctly interesting.

"We have so far considered only phenomena in which the change in surface energy has been held to be the determining factor, and have disregarded the fact, with which we are already familiar, that boundary surfaces are generally the seats of electric charges. It is more than probable that these may affect adsorption, and there are some striking phenomena in which the electric factors appear to play the most important or indeed an exclusive part. If, for instance, a ferric hydroxide solution is passed through a column of sand—carefully purified—the hydroxide is completely retained, and only clear water leaves the end of the column for a time. The same thing occurs with a solution of night blue, as has been shown by Dreaper and Davis. In both cases the sand is capable of retaining only a quite definite quantity: when this has been reached, the liquid passes through unaltered. Both ferric hydroxide and night blue belong to the not very numerous class of positive colloids, while silica, like most substances, assumes a negative charge in contact with water. It is, therefore, reasonable to assume that the positive colloidal particles are discharged and retained by the negatively charged sand grains. Night blue is retained with such tenacity even by a smooth glass surface that vessels which have contained the solution cannot be washed clean with water alone. The phenomenon does not occur in an alcoholic solution of the dye, and, if the latter has been adsorbed on sand from an aqueous solution it can be removed by subsequent washing with alcohol."

While one cannot agree throughout with the author's point of view, he has lived up to his preface and the book is well worth reading. The directions for making various sols, pp. 8-9, are welcome. *Wilder D. Bancroft*

**Der kolloide Zustand der Materie.** By Leonardo Cassuto. Translated by Johann Matulla. 23 × 18 cm; pp. ii + 247. Dresden: Theodor Steinkopff, 1913. Price 7.50 marks, paper; 8.50 marks, bound.—The author takes the ground that we have no satisfactory theory of colloids and that therefore it is better to present the facts in an orderly fashion without much reference to theory and then to discuss the inadequacies of the existing theories in the last chapter or two. This is a frank and honest way of meeting the existing difficulties. Whether it is a satisfactory one is a matter of opinion. There are people—the reviewer among them—who think that there is no special object in writing a book unless one has something new to offer, and who believe that a satisfactory theory of colloids is more important than a recapitulation of the facts. However that may be, there is no question but that the author has done well the task that he set himself.

The subject is treated under the headings: introduction; optical properties of disperse systems; the ultra-microscope; estimation of degree of dispersity; Brownian movements; osmotic pressure; coagulation; swelling and jelling; adsorption; the factors of stability of colloid systems, methods of preparation of colloid systems; theories of the colloid state; general review of the theories of colloids; systematics of colloids.

The preface is interesting enough to warrant quoting though not in full.

"If a man, whose only knowledge of colloids is what he gets from general physics, tries to obtain a more detailed familiarity with the subject, he finds himself lost among an enormous number of facts which he cannot correlate readily. It is often justifiable to assume that some of the observations are true only for one particular substance and perhaps for one set of conditions. Even when a definite law or a clear conception can be formulated, it often happens that the investigator is thrown into despair by the occurrence of numerous exceptions for which it is apparently impossible to find a satisfactory explanation.

"There is no help to be expected from the different theories, for they serve only to increase and not to diminish our perplexity. On the one hand we have the determined upholders of the physical theories and on the other hand the equally obstinate defenders of the chemical theories, each side presenting numberless experimental facts as well as logically flawless deductions in support of its views. In spite of this there are such surprising differences between these theories, and such contradictions that there seems to be no possible way of reconciling them. We find these discouraging differences of opinion and uncertainties even in regard to the fundamental definitions. We ask ourselves what a colloid is and the answer is that it is better not to attempt a definition. It is also difficult to decide whether one is to adopt the view that a colloidal system is a one-phase system or whether one is to consider it a polyphase system. What do we mean by a phase? This last point has given rise to violent discussion and people are far from being agreed in regard to it.

"Such a confusion is not to be wondered at. The enormous amount of

material is due to the rapidly growing interest in colloid chemistry during the last twenty years, to the increasing perfection in our methods of measurement, and to the wealth of material for study. As for the theories, the prevailing uncertainty is justified by the fact that we are dealing with the difficult problem of the constitution of matter. To have formulated this problem was the chief triumph of the leaders of the past century and its solution will be one of the greatest accomplishments of the human mind." *Wilder D. Bancroft*

**Modern Research in Organic Chemistry.** By *F. G. Pope*. 19 × 13 cm; pp. v + 324. New York: D. Van Nostrand Co., 1913. Price: \$2.25 net.—The object of the book is given by the following words from the preface. "Organic Chemistry, in the stricter sense of the term, still offers a vast number of problems for solution; with the rapid progress made, the problems of one decade become the commonplaces of the next, and it is worth while to take an occasional general survey, considering the lines in which immediate progress is probable." The general survey thus referred to is presented under the headings: the polymethylenes; the terpenes and camphor; the uric acid or purine group; the alkaloids; the relation between the color and constitution of chemical compounds; salt formation, pseudo-acids and bases; the pyrones; ketens; ozonides, triphenylmethyl; the Grignard reaction.

The chapter on color and constitution is one of those that interests the physical chemist and the final paragraph, p. 220, seems worth quoting. "Despite the activity shown in the experimental investigation of this subject, it is obvious that as yet no real relationship between color and constitution has been determined, but it does appear probable that the final theory of selective absorption will be one which takes full cognizance of color (using the term in its broadest sense) as an essentially dynamic property, the molecule being regarded not as a rigid structure, but as one whose components are held together by restraining influences, and which are capable of rapid oscillations. Although in particular groups much valuable generalization has been made, there is still very much unsolved, and it seems that progress will be made by a systematic study of selective absorption coupled with chemical evidence of constitution. In this way it may become possible to recognize in a general manner the groupings associated with the production of the vibrations giving rise to certain types of absorption, and hence to predict color."

In the preface J. T. Hewitt gives brief abstracts of chapters of the book and then says:

"While all this strictly organic work was in progress, other investigations followed a different line, endeavoring to trace relationships between the physical properties of substances and their chemical constitution. In the early days of this type of work, inorganic substances received possibly rather more than their fair share of attention: it might perhaps be contended that latterly the pendulum had swung too far in the other direction. Certainly organic compounds offer one immense advantage: there is usually no doubt either as to the molecular weights or the arrangement of linkages in the substances under investigation. Prosecution of researches of this character has led to striking advances; our ideas as to the arrangement of atoms in space and the rearrangement

of structure which often occurs on salt formation, have undergone considerable change. Workers in this branch of science are occasionally unduly optimistic, but the success which has attended some of the attempts to refer properties to constitution, notably in the case of molecular volume and molecular refraction, can only act as a greater incentive to work. Organic chemists have achieved much, and as the habit of simply recording the melting-points and analytical data of new compounds dies out, it will be more clearly recognized what an enormous field of work lies in front of us." *Wilder D. Bancroft*

**Elektrochemisches Praktikum.** By *Erich Müller*. 23 × 17 cm; pp. v + 221. Dresden: Theodor Steinkopff, 1913. Price 8 marks.—Since 1901 a laboratory course in electrochemistry has been given at the Dresden Polytechnic, first under Professor Foerster and later under Professor Müller. It has been the intention to arrange a course which every student should take, and not merely those who are specializing in electrochemistry. The student begins with experiments illustrating Ohm's law and polarization phenomena. In connection with Ohm's law the reviewer suggests a few experiments on the theory of measuring instruments—on measuring current with a voltmeter or potential differences with an ammeter. After the experiments on the relation between current and voltage come the experiments on coulometers, conductivity, and electromotive forces. It is of course sufficiently accurate in many cases to use the Ostwald capillary electrometer, p. 27, when measuring electromotive forces; but it would be well to point out to the student that this instrument is not sensitive enough for really accurate work.

A number of experiments on electrolytic analysis follow. The book is quite clear as to the theory of electrolytic separation by the constant current method. On the other hand, the rapid methods of electrolytic analysis are represented only by the crudest one of all, the one in which the electrolyte is stirred and the cathode is stationary. The preparation of inorganic compounds includes an excellent series of experiments on the electrolysis of chloride solutions, and also experiments on perchlorate, persulphate, plumbic chloride, cobaltic sulphate, potassium bichromate and on the reduction of vanadic salts. The reviewer believes that it would be well to have an experiment based on Oettel's work and showing the effect of relative size of electrodes on the electrolysis of mixed ferric and ferrous salt solutions. It is a very common error for people to use any electrodes which come handy and to trust to the hypothetical intelligence of the electric current to pull them through.

Under organic preparations we find the preparation of iodoform from alcohol, of bromoform from acetone, and of isopropyl alcohol from acetone, together with six experiments on the reduction products of nitrobenzene. High temperature experiments include the electrolysis of fused lead chloride, and the preparation of magnesium, aluminum, calcium carbide, ferro-chrome and ferro-silicon. The book is an admirable one and to be recommended to everybody.

*Wilder D. Bancroft*

**Electroplating.** By *W. R. Barclay and C. H. Hainsworth*. 19 × 13 cm; pp. iii + 400. New York: Longmans, Green & Co., 1913. Price \$2.10.—



This extremely interesting book has been written for the practical electroplater from the standpoint of the scientist. It is the best plating hand-book that the reviewer has ever seen. There is not the usual jumble of impractical formulae, the formulae given are those only which are used in practice. While the additions to some of the solutions may be a little hard to explain, from the theoretical standpoint, it is certain that results have been obtained in practice, and they are given on the strength of these results. This book can therefore be highly recommended to the practical plater and should receive wide circulation.

After a discussion of the fundamental principles of electrochemistry, etc., an excellent chapter is given on preparatory processes. The important subject of electro-cleaning and sand-blasting are given space here.

The treatment of colloidal addition agents is not as full as it might be. The author is inclined to assume that there is something weird about their action.

Chapters on the deposition of the various metals are then included. A chapter on the deposition of brass, with the mention of other alloys which are not used in practice, and finally, chapters on finishing and coloring are given.

Formulae for plating by immersion are conspicuous by their absence, except in the case of gold, for instance, where they are used commercially.

In most cases the current densities as well as the voltages are given. Where there is any doubt about a magnitude,—as it should be—no hard and fast statement is made. Many points are left open, therefore, for the practice and ingenuity of the plater. The book is, therefore, well worth close study.

C. W. Bennett

**Eine Anleitung zur Ausführung physiko-chemischer Messungen bei höheren Temperaturen.** By F. M. Jaeger. 25 × 16 cm; pp. iii + 152. Groningen: J. B. Wolters, 1913. Price, \$1.30.—The author worked for some time in the Geophysical Laboratory in Washington and learned the methods in vogue there. He has transferred these methods to the high temperature laboratory at Groningen and has now written a book concerning them which should be very useful to any one interested in this line of work and unable to get the information at first hand. The chapters are entitled: measurement of temperature; arrangement of furnaces and heating apparatus; exact determination of equilibrium temperatures; microscopic investigation and characterization of solid phases; optical and thermal data in regard to solid phases; measurement of other properties at extremely high temperatures.

Wilder D. Bancroft

**Einführung in die Spektrochemie.** By G. Urbain. Translated by Ulfilas Meyer. 23 × 16 cm; vii + 213. Leipzig: Theodor Steinkopff, 1913. Price, 10 marks.—The French edition of this valuable book has already been reviewed (17, 636). It is only necessary to call attention to the prompt appearance of a German translation.

Wilder D. Bancroft



## SOME NEW RELATIONS BETWEEN THE PHYSICAL PROPERTIES OF LIQUIDS

BY DANIEL TYRER

It is a remarkable fact that when an empirical relationship between certain of the physical properties of a liquid is found to be true for a given liquid over a certain range of temperature, it is always found to be true for all other liquids over a similar temperature range. For instance, the well-known Ramsay-Eötvös equation for the surface tension of a liquid is true not only for one liquid or for a certain class of liquids but for all liquids.<sup>1</sup> And if we discover a new relationship and find it applicable to one liquid we may be sure that it is also applicable to others.

These remarks do not, however, apply to all physical properties but only to that class which are not what is called "constitutive," that is, do not depend upon the inner nature or structure of the molecule. A constitutive property, for example, is viscosity and, as is well known, this does not lend itself to the construction of relationships with other physical properties. We may find a relationship between viscosity and other properties which is true for one liquid but which does not hold or only roughly holds for other liquids which are chemically dissimilar. Specific heat is another case of a constitutive property. No general relationship which expresses the variation of the specific heats of liquids with temperature has yet been discovered, for such a relationship is not possible.

On the other hand, other physical properties such as density, surface tension, latent heat, etc., are not constitutive or only slightly so and a relationship between such physical properties is always found applicable to all liquids.

---

<sup>1</sup> Associated liquids are included in this statement as well, for presumably if we knew the correct molecular weights and the correct values of the other terms in the equation, they would give an equally good agreement as do non-associated liquids.

But probably every physical property is to some extent, however slightly, of a constitutive character and if we take two liquids of extremely dissimilar character (*i. e.*, chemically dissimilar) we find that many relationships are only approximately applicable to both or else fail altogether to agree with the experimental data. For instance, the constant in the Ramsay-Eötvös surface-tension equation is usually equal to about 2.12 but it has been found by Walden,<sup>1</sup> to take a single case, that for tristearin the constant is about 6.2. This is not due to any possible association, for in this case the constant is decreased.

In looking for new relationships between the physical properties of liquids it is advisable, therefore, to study properties which are not constitutive or only slightly so, as for example latent heat and surface tension. The former property in particular lends itself to the discovery of empirical relations with other properties and it is this property which has formed the basis of the present study. Already there exist three accurate empirical<sup>2</sup> latent heat relations:

$$\text{Mills's Equation} \quad lm = \mu(d_l^{1/3} - d_v^{1/3})$$

$$\text{An Equation}^4 \quad lm = C(d_l^2 - d_v^2)$$

$$\text{Dieterici's Equation}^5 \quad lm = C_1 T \log \frac{d_l}{d_v}$$

where  $l$  is internal latent heat, *i. e.*, latent heat minus the external work done in vaporization,  $m$  is molecular weight,  $d_l$  and  $d_v$  the densities of liquid and saturated vapor respectively and  $\mu$ ,  $C$  and  $C_1$  are constants, the first two being dependent on the nature of the liquid though independent of the

<sup>1</sup> Walden: *Zeit. phys. Chem.*, **75**, 555 (1910).

<sup>2</sup> The relations mentioned were not all discovered empirically but their physical meaning is not sufficiently certain to justify any other description.

<sup>3</sup> *Jour. Phys. Chem.*, **6**, 209 (1902); **8**, 383 (1904); **8**, 593 (1904); **9**, 402 (1905); **10**, 1 (1906).

<sup>4</sup> This equation appears to have been first discovered by Batschinski (*Drude's Ann.*, **14**, 288 (1904)), and was later discovered independently and tested by Kleeman (*Phil. Mag.*, **20**, 678 (1910)).

<sup>5</sup> *Drude's Ann.*, **25**, 569 (1908).

temperature, and  $C_1$  is approximately the same for all normal liquids.

These three relationships, together with various surface-tension relations, can be combined with any new latent heat relation that may be discovered and, as will be seen later, they supply a means of producing a number of interesting new relationships.

To avoid the repeated explaining of the terms used continually throughout this paper they are all collected and given below with their meanings:

$L$  = ordinary latent heat of vaporization.

$l$  = internal latent heat, *i. e.*,  $L$  minus external work of vaporization.

$T$  = temperature (absolute).

$T_c$  = critical temperature (absolute).

$T_s$  = boiling point (absolute).

$d_l$  = density of liquid.

$d_v$  = density of saturated vapor.

$d_c$  = critical density.

$d_s$  = density at the boiling point.

$\gamma$  = surface tension.

$m$  = molecular weight.

$C$  is a constant independent of temperature but dependent on the nature of the liquid.

$K$  is a constant the same for all liquids at all temperatures.

In regard to the experimental data used in the calculations the internal latent heats are taken from tables calculated by J. E. Mills<sup>1</sup> by aid of the Clapeyron-Clausius formula, using the experimental data of S. Young.

The surface-tension data are those of Ramsay and Shields.<sup>2</sup>

The densities of liquids and saturated vapors are according to Young.<sup>3</sup>

<sup>1</sup> Jour. Phys. Chem., 8, 383 (1904); 10, 1 (1906); Jour. Am. Chem. Soc., 31, 1099 (1909); 13, 512 (1909).

<sup>2</sup> Phil. Trans., 184A, 647 (1893); Zeit. phys. Chem., 12, 433 (1893).

<sup>3</sup> Proc. Roy. Dub. Soc., 12, 374 (1910).

The following latent heat relation has been discovered empirically:

$$lm = \frac{C_1(T_c - T)^{1/2}}{d_l + d_v} \dots \dots \dots (1)$$

$C_1$  is a constant dependent on nature of the liquid. To prove the validity of the equation the latent heats of four dissimilar liquids have been calculated by aid of the equation and the results are compared in the following tables with the thermodynamic values of Mills (see above). Under  $l$  are the thermodynamic values and under  $l_1$  the values calculated according to equation (1):

## ETHER

$$T_c = 466.8^\circ; m = 74.08$$

$t^\circ$	$d_l$	$d_v$	$l$	$l_1$
0	0.7362	0.00083	85.41	84.94
20	0.7135	0.00187	80.04	80.47
40	0.6894	0.00373	75.02	75.41
60	0.6658	0.00677	70.40	70.37
80	0.6402	0.01155	65.40	65.13
100	0.6105	0.0187	60.40	59.67
120	0.5764	0.0293	54.53	53.77
140	0.5385	0.0449	48.13	47.21
160	0.4947	0.0691	39.81	39.35
170	0.4658	0.0873	34.18	34.49
190	0.3663	0.1620	16.59	18.10

## BENZENE

$$T_c = 561.5^\circ; m = 78.05$$

$t^\circ$	$d_l$	$d_v$	$l$	$l_1$
0	0.9001	0.000121	99.16	102.1
80	0.8145	0.00272	86.70	86.63
100	0.7927	0.00469	82.37	82.30
120	0.7692	0.00763	77.39	77.85
160	0.7185	0.0173	69.48	68.60
180	0.6906	0.0249	65.21	63.65
200	0.6610	0.0355	59.75	58.25
220	0.6256	0.0503	53.76	52.42
240	0.5852	0.0715	46.53	45.72
260	0.5327	0.1040	37.55	37.40
280	0.4514	0.2209	23.45	22.29

## n-HEPTANE

$$T_c = 539.9; m = 100.13$$

$t^\circ$	$d_L$	$d_v$	$l$	$l_1$
0	0.7005	0.01672	84.44	82.68
80	0.6311	0.0020	72.59	72.82
100	0.6124	0.00358	68.81	68.82
120	0.5926	0.00607	64.58	64.66
140	0.5711	0.00977	60.01	60.35
160	0.5481	0.01508	55.61	55.82
180	0.5232	0.02242	51.62	51.01
200	0.4952	0.03304	46.63	45.76
220	0.4616	0.04892	40.57	39.67
240	0.4177	0.07446	32.60	32.14
250	0.3877	0.09461	27.17	27.14
260	0.3457	0.1289	19.02	19.75

## TIN TETRACHLORIDE

$$T_c = 591.7; m = 260.8$$

$t^\circ$	$d_L$	$d_v$	$l$	$l_1$
100	2.0186	0.00576	29.01	28.98
120	1.9639	0.00994	27.70	27.62
140	1.9073	0.01616	26.21	26.19
160	1.8481	0.02506	24.75	24.73
180	1.7873	0.03759	23.33	23.20
200	1.7224	0.05450	21.59	21.62
220	1.6488	0.07728	19.98	19.97
240	1.5667	0.1083	18.15	18.16
260	1.4747	0.1520	16.02	16.14
280	1.3628	0.2160	13.45	13.73

There is a good agreement between the observed latent heats and the calculated. The greatest divergence is at the initial temperature  $0^\circ$  but this is probably due to the somewhat uncertain value of the observed latent heat at this temperature. Otherwise the disagreement is on the average less than one percent and this is probably no greater than the experimental error in the data.

The value of the constant  $C_1$  in equation (1) differs for different liquids but we may generalize it in the following way. This, it may be added, is a general method of generalizing a constant.

At the boiling point of a liquid the equation may be written

$$(L - E)m = \frac{C_1(T_c - T_s)^{1/3}}{d_s^{1/3} - d_v^{1/3}}$$

$E$  being external work of vaporization and, therefore,  $L - E = l$ . Now at this point according to the law of corresponding states we have  $T_c \propto T_s$  and  $d_s \propto d_v$ , so that we may write

$$(L - E)m = \frac{C_1 K \cdot T_s^{1/3}}{d_s^{1/3}}$$

$K$  being a constant the same for all liquids.

Now according to Trouton's well-known equation we have

$$Lm = K_0 T_s$$

and

$$Em = PV = RT_s$$

Therefore,

$$(L - E)m = T_s(K_0 - R)$$

Therefore,

$$T_s(K_0 - R) = \frac{C_1 K \cdot T_s^{1/3}}{d_s^{1/3}}$$

or

$$C_1 = K_1 T_s^{2/3} d_s^{1/3}$$

$K_1$  being constant for all liquids.

Equation (1) may, therefore, be written

$$lm = K_1 T_s^{2/3} d_s^{1/3} \frac{(T_c - T)^{1/3}}{d_v^{1/3} + d_s^{1/3}} \dots \dots \dots (1a)$$

The values of  $K_1$  have been determined for a number of liquids and are given in the following table:

Liquid	$K_1$	Liquid	$K_1$
Ether	26.86	Isopentane	25.87
Benzene	25.70	<i>n</i> -Pentane	26.29
<i>n</i> -Heptane	28.60	<i>n</i> -Hexane	27.30
Diisopropyl	26.46	Bromobenzene	26.56
Diisobutyl	27.90	Chlorobenzene	27.07
Carbon tetrachloride	25.74	Iodobenzene	26.53

Mean value of  $K_1 = 26.74$

For the boiling-point constants  $T$ , and  $d$ , we may, of course, substitute their proportional values  $T_c$  and  $d_c$  but the agreement between the values of  $K_1$  for different liquids is not then so good. The constancy of  $K_2$  depends, of course, upon the validity of the law of corresponding states and upon Trouton's equation.

A further new relationship may be obtained by combining equation (1) with Mills' equation (see page 718) so that the latent heat is eliminated. This relation may be written

$$(T_c - T)^{1/3} = C_2(d_L^{2/3} - d_v^{2/3}) \dots \dots \dots (2)$$

If we generalize the constant  $C_2$  by taking the equation at the boiling point and applying the law of corresponding states as before, we find

$$C_2 = K_2 \frac{T_s^{1/3}}{d_s^{2/3}}$$

$K_2$  being an independent constant.

The equation may then be written

$$(T_c - T)^{1/3} = K_2 \frac{T_s^{1/3}}{d_s^{2/3}} (d_L^{2/3} - d_v^{2/3}) \dots \dots \dots (2a)$$

The validity of this equation depends, of course, upon the validity of the equations from which it has been deduced. Since these appear to hold true within limits of experimental error it follows theoretically that equation (2) should hold equally good. But it is not always practically true that a relation deduced in this way from other relationships agrees with facts. For an empirical relationship never holds absolutely true and when two such relationships are equated together thus producing a third relationship, certain of the variables may be thrown into such conspicuity in the resultant equation that it may only agree roughly with the facts. It is, therefore, always necessary to test the relationships though they may be founded on others which give a very good agreement with experimental data.

The approximate validity of equation (2a) is shown in the four following cases:

CARBON TETRACHLORIDE				CHLOROBENZENE			
$T_c = 556.1^\circ; T_s = 349.7;$				$T_c = 632.1^\circ; T_s = 405.0;$			
$d_s = 1.483$				$d_s = 0.9842$			
$t^\circ$	$d_L$	$d_v$	$K_2$	$t^\circ$	$d_L$	$d_v$	$K_2$
0	1.6327	0.0003	0.876	0	1.1278	0.04169	0.877
100	1.4343	0.01026	0.855	130	0.9836	0.00341	0.847
120	1.3902	0.01634	0.854	140	0.9723	0.00432	0.845
140	1.3450	0.02481	0.851	160	0.9480	0.00676	0.840
160	1.2982	0.0365	0.851	180	0.9224	0.01020	0.837
180	1.2470	0.0525	0.850	200	0.8955	0.01500	0.835
200	1.1888	0.0742	0.852	220	0.8672	0.02145	0.832
240	1.0444	0.1464	0.862	260	0.8016	0.0417	0.833
260	0.9409	0.2146	0.874	300	0.7220	0.0778	0.837
280	0.7634	0.3597	0.822	333	0.6274	0.1360	0.847

BENZENE				DIISOBUTYL			
$T_c = 561.5^\circ; T_s = 353.2;$				$T_c = 549.8^\circ; T_s = 382.2;$			
$d_s = 0.8135$				$d_s = 0.6184$			
$t^\circ$	$d_L$	$d_v$	$K_2$	$t^\circ$	$d_L$	$d_v$	$K_2$
0	0.9001	0.000121	0.876	0	0.7102	0.0447	0.818
90	0.8145	0.00272	0.857	90	0.6328	0.00217	0.794
100	0.7927	0.00469	0.853	100	0.6236	0.00297	0.792
120	0.7692	0.007634	0.851	120	0.6046	0.00523	0.788
140	0.7440	0.01174	0.849	140	0.5841	0.00853	0.784
160	0.7185	0.01734	0.847	160	0.5629	0.0132	0.781
180	0.6906	0.02487	0.845	180	0.5383	0.0196	0.780
200	0.6610	0.0355	0.844	200	0.5117	0.0287	0.779
220	0.6256	0.0503	0.848	220	0.4810	0.0420	0.780
240	0.5852	0.0715	0.853	240	0.4434	0.0622	0.788
260	0.5327	0.1040	0.864	260	0.3912	0.0970	0.791
				270	0.3482	0.1321	0.804

It will be noticed that the value of  $K_2$  in each of the above cases does not remain quite constant but decreases slightly with rise of temperature, reaches a minimum and then increases again as the critical point is approached. Excepting the initial



values at  $\alpha$  this variation, however, does not amount to more than about two percent.

If in the Ramsay-Eötvös surface-tension equation

$$\gamma \left(\frac{m}{d}\right)^{2/3} = K(T_c - T - \alpha)$$

we omit the small quantity  $\alpha$  and then equate the resulting equation with equation (1), we obtain the following interesting relation between latent heat and surface tension:

$$\frac{\gamma^{1/2}}{l} = C_3 d_L^{1/3} (d_L^{1/3} + d_v^{1/3}) \dots \dots \dots (3)$$

Walden<sup>1</sup> has shown that the simpler equation

$$\gamma \frac{m}{d} = K_0 (T_c - T - \alpha_0)$$

holds as well as the Ramsay-Eötvös equation, and if we combine this equation with equation (1) we obtain

$$\frac{\gamma^{1/2}}{l} = C_4 d_L^{1/3} (d_L^{1/3} + d_v^{1/3}) \dots \dots \dots (4)$$

The validity of these two equations is tested in the following tables. As the values of  $l$ ,  $d_L$  and  $d_v$  have already been given in previous tables they are here omitted:

ETHER				BENZENE			
$l$	$\gamma$	$C_3 \times 10^4$	$C_4 \times 10^4$	$l$	$\gamma$	$C_3 \times 10^4$	$C_4 \times 10^4$
20	16.49	369.5	349.7	80	20.28	306.7	313.8
40	14.05	336.3	350.6	100	18.02	306.9	314.9
60	11.80	333.2	348.6	120	15.71	308.3	317.4
80	9.67	334.5	350.8	140	13.45	305.2	315.3
100	7.63	327.4	345.8	160	11.29	301.8	313.1
120	5.65	323.7	344.1	180	9.15	294.8	308.6
140	3.77	316.7	340.0	200	7.17	295.0	308.6
160	2.08	312.2	337.6	220	5.25	293.0	308.7
				240	3.41	291.2	309.0
				260	1.75	288.3	309.2

<sup>1</sup> Zeit. phys. Chem., 65, 129 (1908).

## CARBON TETRACHLORIDE

$t$	$l$	$\gamma$	$C_2 \times 10^4$	$C_1 \times 10^4$
80	41.64	18.71	442.3	423.6
100	39.64	16.48	437.2	420.1
120	37.48	14.32	439.5	423.7
140	35.27	12.22	438.0	423.8
160	33.28	10.22	432.5	420.2
180	30.83	8.26	430.6	419.9
200	28.22	6.34	426.9	418.3
220	25.35	4.47	419.7	414.4
240	21.91	2.74	410.5	408.5
260	17.15	1.20	397.6	400.4
270	13.62	0.59	397.1	403.5

## CHLOROBENZENE

$t$	$l$	$\gamma$	$C_2 \times 10^4$	$C_1 \times 10^4$
150	65.45	17.67	346.2	347.2
160	64.14	16.62	343.5	345.8
180	61.67	14.66	339.5	342.6
200	58.50	12.72	337.9	341.9
220	55.55	10.81	333.6	338.9
240	52.25	8.94	330.0	336.6
260	48.17	7.14	329.2	337.4
270	45.80	6.26	329.5	339.0

It will be noticed that the value of  $C_2$  steadily decreases as the temperature rises. The change is so great that we cannot even consider equation (3) as holding approximately. Neglecting the small quantity  $\alpha$  in the Ramsay-Eötvös formula accounts partially for the non-validity of the equation. The inclusion of  $\alpha$  causes the equation to be invalid near the critical point, since  $l$  does not become zero until the critical temperature is reached.

On the other hand, the other equation deduced from Walden's relation appears to hold with a fair degree of accuracy. The greatest deviations of the constant  $C_1$  are in the neighborhood of the critical temperature and here greater deviations are only to be expected on account of the smaller degree of accuracy of the experimental data, particularly of the surface

tension  $\gamma$ , which becomes relatively very small as the critical temperature is approached.

If we equate equation (2) with the Ramsay-Eötvös equation (neglecting  $\alpha$ ) we obtain a new surface-tension equation, *vis.*,

$$\gamma^{1/2} = C_5 d_L^{2/3} (d_L^{2/3} - d_c^{2/3}) \dots \dots \dots (5)$$

And if instead of the Ramsay-Eötvös equation we use Walden's<sup>1</sup> equation we obtain

$$\gamma^{1/2} = C_6 d_L^{1/2} (d_L^{1/2} - d_c^{1/2}) \dots \dots \dots (6)$$

These two equations give the surface tension in terms only

ETHER			BENZENE		
$t^\circ$	$C_5$	$C_6$	$t^\circ$	$C_5$	$C_6$
20	3.462	3.594	80	3.347	3.424
40	3.463	3.610	100	3.335	3.422
60	3.430	3.590	120	3.317	3.414
80	3.408	3.573	140	3.302	3.411
100	3.390	3.566	160	3.285	3.408
120	3.373	3.586	180	3.320	3.408
140	3.333	3.570	200	3.250	3.405
160	3.267	3.532	220	3.242	3.415
170	3.225	3.510	240	3.216	3.414
180	3.150	3.445	260	3.180	3.410

CARBON TETRACHLORIDE			CHLOROBENZENE		
$t^\circ$	$C_5$	$C_6$	$t^\circ$	$C_5$	$C_6$
20	1.958	1.855	150	2.788	2.800
80	1.927	1.846	160	2.767	2.783
100	1.918	1.843	180	2.767	2.792
120	1.909	1.840	200	2.756	2.790
140	1.904	1.842	220	2.742	2.787
160	1.896	1.842	240	2.733	2.788
180	1.890	1.845	260	2.723	2.791
200	1.885	1.849	280	2.716	2.798
220	1.869	1.845	300	2.693	2.793
240	1.844	1.835	320	2.691	2.814
260	1.774	1.786	333	2.693	2.837
270	1.756	1.785			

<sup>1</sup> Loc. cit.

of the densities of liquid and saturated vapor. Their validity is tested in the preceding tables. The experimental data having already been given in previous tables are here omitted.

As in the previous case, it will be observed that the value of the constant  $C_5$  gradually decreases as temperature rises. But the decrease is only small, being on the average about five percent for a wide range of temperature, from the ordinary temperature to the critical point. We may consider relation (5) approximately true. With the other constant,  $C_6$ , we find a remarkable constancy, the only variations of any appreciable magnitude being near the critical point, and these can easily be due to experimental inaccuracies in the data. We may consider equation (6) as holding true to within limits of experimental errors of the data.

We may generalize the constants  $C_5$  and  $C_6$  in the following manner:

At the boiling point, since densities of liquid and vapor are proportional, we may write the equations

$$\begin{aligned}\gamma^{1/3} &= C_5 d_s^{2/3} \cdot K d_s^{2/3} \\ \gamma^{1/3} &= C_6 d_s^{1/3} \cdot K d_s^{2/3}\end{aligned}$$

Now Kistiakowski<sup>1</sup> has shown that the following relation is true at the boiling point:

$$\alpha^2 m = K \Gamma_s$$

where  $\alpha^2$  is the capillary rise in a tube 1 mm. radius.

Since

$$\frac{\alpha^2 d}{2} = \gamma$$

we have

$$\gamma^{1/3} = K_1 \frac{d_s^{1/3} \Gamma_s^{1/3}}{m^{1/3}}$$

Substituting this value of  $\gamma^{1/3}$  in the above equations we find

$$C_5 = \frac{K_5 \Gamma_s^{1/3}}{m^{1/3} d_s^{2/3}}$$

and

$$C_6 = \frac{K_6 \Gamma_s^{1/3}}{m^{1/3} d_s^{1/3}}$$

<sup>1</sup> Zeit. Elektrochemie, 12, 513 (1906).

$K_3$  and  $K_4$  are constants which should be the same for all liquids. The mean values of  $K_3$  and  $K_4$  for the four liquids given on p. 727 are:

	$K_3$	$K_4$
Ether	1.70	1.75
Benzene	1.76	1.798
Carbon tetrachloride	1.71	1.817
Chlorobenzene	1.77	1.815
Mean	1.74	1.795

The following relationship was discovered empirically:

$$\frac{\gamma}{l(d_L - d_v)^{5/3}} = C_7 \dots \dots \dots (7)$$

$C_7$  being a constant dependent on the nature of the liquid, and the other terms have their usual meaning.

We may generalize  $C_7$  by taking the equation at its boiling point and then combining with Trouton's equation and Kistiakowski's<sup>1</sup> equation. We thus find

$$C_7 = \frac{K_7}{d_s^{5/3}}$$

We may, therefore, write equation (7)

$$\frac{\gamma d_s^{5/3}}{l(d_L - d_v)^{5/3}} = K_7 \dots \dots \dots (7a)$$

The validity of this equation is proved by the constancy of the values of  $K_7$ . The experimental data having already been given before is omitted here.

The constancy of  $K_7$  is quite good. Near the critical temperature small deviations are only to be expected as the errors in the data become much greater. The mean value of  $K_7$  for the different liquids is 0.2970. The deviations of  $K_7$  for different liquids from a constant value can only be considered as due for the most part to small constitutive influences. Ether is perhaps very slightly associated. The equation may

<sup>1</sup> Loc. cit.

ETHER		BENZENE		CHLOROBENZENE		CARBON TETRACHLORIDE	
$t^\circ$	$K_1$	$t^\circ$	$K_1$	$t^\circ$	$K_1$	$t^\circ$	$K_1$
20	0.2790	80	0.2908	150	0.2964	80	0.3112
40	0.2807	100	0.2928	160	0.2962	100	0.3136
60	0.2795	120	0.2973	180	0.2962	120	0.3170
80	0.2795	140	0.2978	200	0.2972	140	0.3200
100	0.2803	160	0.2968	220	0.2959	160	0.3197
120	0.2837	180	0.2968	240	0.2965	180	0.3231
140	0.2818	200	0.3070	260	0.3005	200	0.3264
160	0.2797	220	0.3058	280	0.3007	220	0.3248
180	0.2831	240	0.3067			240	0.3228
		260	0.3160			250	0.3171
		270	0.3080			260	0.3180

be considered as holding true within limits of error in the data. It is interesting to observe that the equation does not include the molecular weight and, therefore, for an associated liquid which does not dissociate on boiling it should be also valid.

By equating equation (7) with known surface-tension relationships so as to eliminate  $\gamma$  we can obtain new latent heat relationships.

Kleeman<sup>1</sup> has discovered the following surface-tension relation:

$$\gamma = C(d_L - d_v)^4$$

where C is a constant dependent on the nature of the liquid. Generalizing C as before by equating with Kistiakowski's relation at the boiling point we find

$$C = \frac{K\Gamma_s}{md_s^4}$$

Now if Kleeman's equation, with this value of C inserted, be equated with equation (7a) and  $\gamma$  eliminated, we obtain the following simple latent heat relation

$$lm = K_s\Gamma_s \frac{(d_L - d_v)^4}{d_s^{4.3}} \dots \dots \dots (8)$$

<sup>1</sup> Phil. Mag., 21, 83 (1911).

In the following table are given values of  $K_s$  in five cases. The experimental data are all contained in previous tables:

ETHER		BENZENE		CHLORO- BENZENE		n HEPTANE		TIN TETRA- CHLORIDE	
$t^\circ$	$K_s$	$t^\circ$	$K_s$	$t^\circ$	$K_s$	$t^\circ$	$K_s$	$t^\circ$	$K_s$
0	19.20	0	19.17	140	18.31	0	19.31	100	19.22
20	18.78	80	19.22	160	18.91	80	19.13	120	19.10
40	18.47	100	19.00	180	18.95	100	18.94	140	18.91
60	18.25	120	18.67	200	18.84	120	18.94	160	18.86
80	18.18	140	18.73	220	18.87	140	18.42	180	18.65
100	18.13	160	18.73	240	18.95	160	18.28	200	18.38
120	18.17	180	18.83	260	18.87	180	18.39	220	18.43
140	18.40	200	18.68	280	19.14	200	18.53	240	18.49
160	18.58	220	18.86			220	18.75	260	18.58
180	19.18	240	18.98			240	19.27	280	18.86
		260	19.50						

The relation appears to hold quite well. In several of the cases the constant  $K_s$  seems to decrease to a minimum value and then to increase to the critical temperature. But this change is only small and it is questionable to what extent it is due to inaccuracy in the data. The mean value of the constant for different liquids is 18.74.

By equating equation (7) with the Ramsay-Eötvös surface-tension equation so as to eliminate  $\gamma$  we obtain the following latent heat relation:

$$\frac{(\Gamma_c - T - \alpha)d_L^{2/3}}{l(d_L - d_v)^{2/3}} = C_1.$$

If also instead of the Ramsay-Eötvös equation we use Walden's modification (see p. 725) we obtain

$$\frac{(\Gamma_c - T - \alpha)d_L}{l(d_L - d_v)^{2/3}} = C_2$$

On testing these two equations it is found that neither of them holds very well. They both give gradually changing constants as temperature rises. Though the change is only small the equations cannot be considered valid. If, however,

we neglect the small quantity  $\alpha$  in the second of these equations we obtain an equation which holds very well for temperatures not higher than  $60^\circ$  below the critical point. The equation may be written

$$\frac{(T_c - T)d_L}{l(d_L - d_v)^{1/3}} = C_9 \dots \dots \dots (9)$$

The validity of this equation over the limited temperature range is shown in the following tables:

ETHER		BENZENE		ISOPENTANE				
$t^\circ$	$C_9$	$t^\circ$	$C_9$	$t^\circ$	$d_L$	$d_v$	$l$	$C_9$
0	3.792	0	3.471	0	0.6392	0.0011	81.35	4.886
20	3.832	100	3.426	20	0.6196	0.0034	75.67	4.970
40	3.862	120	3.461	40	0.5988	0.0045	71.10	4.983
60	3.850	140	3.453	60	0.5769	0.0078	66.20	5.008
80	3.841	160	3.425	80	0.5540	0.0128	61.59	4.987
100	3.838	180	3.400	100	0.5278	0.0202	56.72	4.986
120	3.896	200	3.421	120	0.4991	0.0311	50.89	5.035
		220	3.480	140	0.4646	0.0473	44.04	5.140

BROMOBENZENE

$t^\circ$	$d_L$	$d_v$	$l$	$C_9$
30	1.4815	0.00005	63.58	2.997
100	1.3864	0.0009	57.86	2.982
160	1.2994	0.0052	50.11	3.091
180	1.2697	0.0081	48.52	3.059
200	1.2385	0.0120	46.80	3.027
220	1.2037	0.0175	44.95	3.007
240	1.1689	0.0248	42.47	3.017
260	1.1310	0.0343	40.26	3.007

The general value of  $C_9$  is approximately given by

$$C_9 = K_9 \frac{M}{d_s^{5/3}}$$

The mean value of  $K_9$  found for a number of substances is 0.0300.

By replacing in equation (7) the values of  $l$  given by other



equations we may obtain new surface-tension relations. By equating with equation (1) we obtain the relation

$$\gamma = C_{10}(T_c - T)^{1/2} \frac{(d_L - d_v)^{1/2}}{(d_L + d_v)^{1/2}} \dots \dots \dots (10)$$

Equating with Mills<sup>1</sup> relation we find

$$\gamma = C_{11}(d_L^{1/2} - d_v^{1/2})(d_L - d_v)^{1/2} \dots \dots \dots (11)$$

From Kleeman's<sup>1</sup> relation we obtain

$$\gamma = C_{12}(d_L^2 - d_v^2)(d_L - d_v)^{1/2} \dots \dots \dots (12)$$

and finally from Dieterici's<sup>1</sup> relation we obtain

$$\gamma = C_{13}(d_L - d_v)^{1/2} T \log \frac{d_L}{d_v} \dots \dots \dots (13)$$

These four equations contain so many differently varying terms that a good agreement with experimental results can scarcely be expected. On testing them it was found that equation (12) deviates too much to be even considered as approximately correct. The other three may be considered as approximate relations as the following two cases serve to show:

ETHER				BENZENE			
<i>t</i> <sup>o</sup>	C <sub>10</sub>	C <sub>11</sub>	C <sub>13</sub> × 10 <sup>4</sup>	<i>t</i> <sup>o</sup>	C <sub>10</sub>	C <sub>11</sub>	C <sub>13</sub> × 10 <sup>4</sup>
20	7.42	52.9	539	80	6.63	43.0	399
40	7.44	52.7	541	100	6.48	44.8	409
60	7.35	52.5	541	120	6.54	45.1	412
80	7.48	52.4	542	140	6.61	45.5	415
100	7.56	53.0	547	160	6.66	45.7	415
120	7.67	53.9	555	180	6.67	45.7	414
140	7.67	54.0	556	200	6.74	46.1	417
160	7.54	53.4	549	220	6.86	47.1	425
180	7.41	52.6	542	240	6.91	47.8	430
				260	7.02	49.2	443

The following simple relationship was discovered empirically:

$$lm = C_{14} \sqrt{T_c - T} \dots \dots \dots (14)$$

<sup>1</sup> See page 718.

Equating this equation with Trouton's relation at the boiling point we find  $C_H = K_H T_c^{1/2}$ . We may, therefore, write the equation

$$lm = K_H \sqrt{T_c} (T_c - T) \dots \dots \dots (14a)$$

This equation gives the internal latent heat in terms only of the temperature. Though both sides of the equation approach zero as the critical point is approached it is found on testing the relation that about  $70^\circ$  below the critical point it begins to show deviations. But over the range of temperature between the ordinary temperature and about  $70^\circ$  or  $80^\circ$  below the critical point the relationship holds exceedingly well, as the following tables will prove:

ISOPENTANE		TIN TETRACHLORIDE		BENZENE	
$t^\circ$	$K_H$	$t^\circ$	$K_H$	$t^\circ$	$K_H$
0	19.94	100	21.03	0	19.23
20	19.62	120	21.07	80	19.77
40	19.64	140	21.03	100	19.75
60	19.67	160	21.07	120	19.63
80	19.92	180	21.25	140	19.85
100	20.34	200	21.25	160	20.19
120	20.75	220	21.57	180	20.80
140	21.40				

HEXAMETHYLENE			FLUOBENZENE		
$t^\circ$	$l$	$K_H$	$t^\circ$	$l$	$K_H$
80	78.63	19.89	80	72.96	20.62
100	74.71	19.91	100	69.71	20.74
120	70.27	19.87	120	65.52	20.62
140	65.68	19.85	140	61.19	20.54
160	61.20	19.98	160	56.86	20.54
180	56.79	20.31	180	52.80	20.78
200	51.42	20.56	200	48.23	21.07

It will be noticed that at the highest temperatures given the value of  $K_H$  is beginning to increase. This increase of the constant continues right to the critical point. Above these temperatures the equation is not valid. It may be

noticed also that there is quite a good agreement between the values of the constant for different liquids. The mean value of  $K_{14}$  is 20.16.

It is, of course, possible to deduce a number of new latent heat and surface-tension relationships by combining the above equation with the others preceding it, but they must all, of course, be applicable only over a limited range of temperature and none of them appear to be of sufficiently simple character to justify their study.

The series of empirical relations put forward in this paper may prove of value in calculating latent heats, surface-tension and critical temperatures. None of the equations have been applied to associated liquids, partly because it is certain that they are not applicable to this class of liquids but chiefly because the author intends to study them specially from this standpoint.

**Summary**

The following empirical relationships have been discovered: In these equations  $l$  is internal latent heat,  $d_l$  density of the liquid,  $d_v$  density of saturated vapor,  $T$  is absolute temperature,  $T_c$  is critical temperature,  $T_b$  is boiling-point temperature,  $d_s$  is the density of the liquid at  $T_b$ ,  $\gamma$  is the surface tension,  $m$  is the molecular weight,  $C_1, C_2, \dots$  etc., are constants independent of the temperature but dependent on the nature of the liquid, and  $K_1, K_2, \dots$  etc., are constants independent both of temperature and nature of the liquid.

- (1)..... $lm = C_1(T_c - T)^{1/2}d_s^{1/2} + d_v^{1/2}$   
 $C_1 = K_1T_b^{3/2}d_s^{1/2}$
- (2)..... $(T_c - T)^{1/2} = K_2T_b^{1/2}d_s^{1/2}(d_l^{1/2} - d_v^{1/2})$
- (3)..... $\gamma^{1/2}/l = C_3d_s^{1/2}(d_l^{1/2} + d_v^{1/2})$
- (4)..... $\gamma^{1/2} = C_3d_s^{1/2}(d_l^{1/2} - d_v^{1/2})$   
 $C_3 = K_3T_b^{1/2}/m^{1/2}d_s^{2/2}$
- (5)..... $\gamma^{1/2} = C_4d_s^{1/2}(d_l^{1/2} - d_v^{1/2})$   
 $C_4 = K_4T_b^{1/2}/m^{1/2}d_s^{2/2}$
- (6)..... $\gamma d_s^{2/2}/l(d_l - d_v)^{1/2} = K_7$

- (7)..... $lm = K_8 T_c (d_L - d_v/d_s)^{1/2}$   
 (8)..... $(T_c - T)d_L/l(d_L - d_v)^{1/2} = C_9 = K_9 m/d_s^{1/2}$   
 (9)..... $\gamma = C_{10}(T_c - T)^{1/2}(d_L - d_v)^{1/2}/(d_L + d_v)^{1/2}$   
 (10)..... $\gamma = C_{11}(d_L^{1/2} - d_v^{1/2})(d_L - d_v)^{1/2}$   
 (11)..... $\gamma = C_{12}(d_L - d_v)^{1/2} T \log. d_L/d_v$   
 (12)..... $lm = K_{14} \sqrt{T_c(T_c - T)}$

Of the above equations 1, 5 and 6 may be considered as agreeing with facts within the limits of experimental error. Equation 8 holds equally well but only over a temperature range not greater than about  $60^\circ$  below the critical temperature. Equation 12 also holds within limits of error in the experimental data but only for temperatures below about  $80^\circ$  from the critical point. The other equations agree approximately with experimental data.

*The Chemistry Dept.  
 The University  
 Manchester  
 August, 1913*

## EXPERIMENTS IN DYEING

BY A. W. DAVISON

This work was undertaken in order to collect data which could be used in devising laboratory and lecture experiments on the theory of dyeing. Though the results are not new in principle, they seem interesting enough to warrant publication. The first experiments were on the behavior of basic and acid dyes in alkaline, neutral and acid solutions. A basic dye is one in which the color is in the basic radical: magenta, safranine, auramine, malachite green, methylene blue, crystal violet, and Bismarck brown, for instance. An acid dye is one in which the color is in the acid radical: crystal ponceau, croceine orange, naphthol yellow, cyanine blue, and acid violet, for instance. A basic dye should be taken up more completely in an alkaline solution than in a neutral solution, and least of all in an acid solution. An acid dye should be taken up more completely in an acid bath than in a neutral one, and least of all in an alkaline solution. Addition of sodium sulphate should cut down the adsorption of acid dyes and increase the adsorption of basic dyes.

In each case a small amount of dye was dissolved in 300 cc water, the solutions usually being so dilute as to be quite transparent. The solutions were then divided into three equal parts. One was called the neutral solution and had nothing added to it. To the second portion 1 cc 6 *N* HCl was added, this portion being afterwards called the acid solution. The alkaline solution was prepared by adding 1 cc 6 *N* NaOH to the third portion. The wool was the best all-wool flannel that could be bought and was cut into strips approximately two inches by six. The cotton was heavy unbleached muslin cut into strips of about the same size. The wool and the cotton were bought at a local dry goods store and were used as bought. The strips were placed in cold solutions which were then heated to boiling for thirty minutes, after which the strips were washed and dried.

The first experiments were made with acid dyes on wool. Fast Green (Elberfeld) dyed wool more deeply in acid solution than in neutral solution; in the alkaline solution practically no dye was taken up by the wool. If a large amount of acid (10 cc) be added to 100 cc of the dye solution, the wool does not take up as much dye as from the neutral solution.

Acid Green B. B. N. Y. (Elberfeld) illustrates admirably the effect of acidity and alkalinity. The woolen strip from the acid solution was dark green; the one from the neutral solution was light green; while the one from the alkaline solution was apparently not colored green at all. With Acid Violet 3R (Elberfeld) the acid and the neutral solutions dyed approximately to the same hue; the strip from the alkaline solution was much lighter. Croceine Orange (Elberfeld) behaved much the same way, there being very little difference between the strips from the acid and the neutral solutions; while the one from the alkaline solution is much less colored. Alizarine Yellow (Elberfeld) gave no satisfactory results, the wool being colored about the same dirty yellow in all three solutions. Chromium is usually used as a mordant with this dye when dyeing wool, so perhaps this was not a fair case.

Fast Blue O (Meister, Lucius and Brüning) was tested in fairly concentrated solutions. The strip dyed in acid solution was colored deep blue; the one in the neutral solution was somewhat less blue and the color tended to a drab; in the alkaline solution the color was a bluish drab. There is the normal change in depth of color; but there is also an abnormal change of color. The dye is given in the books as a mixture of the sodium salts of triphenyl-*p*-rosaniline-monosulphonic acid and of triphenylrosaniline-monosulphonic acid. The dye apparently gives quite different shades with varying concentrations. The tendency to dye greenish drab increases in neutral solution with increasing dilution. Evidently the most concentrated neutral solution was not concentrated enough to give the same color as the acid solution. Addition of NaOH changes the color of the solution to a reddish brown.

A series of runs were now made with basic dyes on wool. Emerald Green (Elberfeld) was tried in concentrated solutions and in dilute solutions. The gradations are excellent, the color being deepest in the alkaline solution and lightest in the acid solution. Addition of too much NaOH decolorizes the solution, a pale green precipitate being formed. A large amount of HCl causes the solution to turn reddish yellow. Neither of these difficulties occurs with the solutions actually used. Care must also be exercised with Victoria Blue B (Elberfeld). Boiling a solution of this dye causes turbidity, owing to the separation of the free base. The addition of concentrated hydrochloric acid causes the separation of a blue precipitate which changes to green and then to a dark reddish brown. Three sets of experiments were made with this dye. With a concentrated solution the acid bath dyed the wool a beautiful blue, the neutral one dyed a deep purple and the alkaline bath a dark blue with a suggestion of purple. With a dilute solution, the deepest color was obtained in the alkaline solution which is as it should be; but the acid bath gave a deeper color than the neutral one, the color in this last bath tending to a drab. With a solution of medium concentration the neutral bath gives a deeper shade than the acid bath; but the alkaline bath did not seem to dye the wool more than superficially and the tint was distinctly off-color. When dyeing wool or silk, Victoria Blue is usually used in an acetic acid solution; for cotton, tannin and tartar emetic are used as a mordant.

Thioflavine T (Matheson) gives very satisfactory results in neutral and acid solutions, the color being lighter in the acid bath. Addition of alkali causes a greenish precipitate to form, which, of course, makes this part of the experiment worthless. Chrysoidine AG (Matheson) gives a deeper color in alkaline solutions, but there is very little difference between the neutral and the acid baths. Safranin O (Meister, Lucius and Brüning) gives admirable gradations especially when rather dilute solutions are used.

As illustrating the general theory, Acid Green B. B. N. Y.

(Elberfeld) is perhaps the best of the acid dyes tested, while Emerald Green (Elberfeld) and Safranin O (Meister, Lucius and Brüning) are to be recommended among the basic dyes.

A few experiments were also made with cotton. In general the effect of acidity and alkalinity is not so striking with cotton as with wool; but the same relations hold. A more concentrated NaOH solution was used than in the experiments on wool. With a more dilute solution there would have been less trouble from precipitation. With the acid dye, Fast Green, an excellent gradation was obtained, the cotton strip dyeing a light green in the acid bath, scarcely in the neutral bath, and not at all in the alkaline bath. Acid Violet and Croceine Orange also work well, a good color being obtained in the acid solution and practically no color in the alkaline bath. Fast Blue dyed cotton a light blue in the acid bath; but the neutral and alkaline solutions had practically no dyeing power at all. With Alizarine Yellow the shade was the same from the neutral and the alkaline solutions. Hydrochloric acid precipitated the dye and there was consequently no color taken up from this solution.

Of the basic dyes Safranin was the one which gave the most satisfactory results with cotton. The color from the acid bath was a pale pink, from the neutral bath a red, and from the alkaline bath a deep red. With Emerald Green a light green was obtained from the acid bath and a beautiful dark green from the neutral bath. Addition of too much alkali causes precipitation of a light green precipitate. It is probable that a more dilute alkali would have given satisfactory results, as was the case with wool; but this was not tried. Thioflavine dyed more strongly in the neutral solution than in the acid one; but the alkaline solution did not work well, owing to precipitation. As was the case with wool, Victoria Blue did not work well in alkaline solution owing to the change of color. Though the neutral bath dyed more deeply than the acid one, the general effect was not so satisfactory.

A few experiments were next made to determine the effect



of sodium sulphate on neutral baths, care being taken that the only difference should be in the sodium sulphate content. To ensure this a solution of 15 grams  $\text{Na}_2\text{SO}_4 \cdot 10\text{H}_2\text{O}$  in 100 cc water was made up and also 200 cc of a dilute solution of the dye. The dye solution was divided into two equal parts, 20 cc of the sodium sulphate solution being added to the one portion and 20 cc water to the other portion. With Acid Green, Croceine Orange and Fast Blue, the wool is dyed a deeper shade in the solution containing no sodium sulphate, the sodium sulphate preventing the dye from being taken up by the wool. With Croceine Orange the color is more yellow as well as lighter when the wool is dyed in the solution containing sodium sulphate. Emerald Green, Victoria Blue and Safranine were taken as the basic dyes and, in each case, less color was taken up by the wool from the solution containing no sodium sulphate than from the solution which does. The results with the basic dyes are the exact reverse of those with the acid dyes. This makes rather an effective experiment.

Some experiments were next made with varying concentrations of sodium sulphate to see whether the effect due to the salt passed through a maximum or a minimum at any concentration. Solutions were made up containing constant quantities of the dye and amounts of crystallized sodium sulphate varying from 16 grams per 100 cc (practically saturated) through 8, 4, 2, 1,  $\frac{1}{2}$ ,  $\frac{1}{4}$ ,  $\frac{1}{8}$ ,  $\frac{1}{16}$ , to  $\frac{1}{32}$  grams per 100 cc in some cases. To secure uniformity, the solutions were heated to boiling; the woolen strips were put in and boiled for an hour after which they were removed, washed by dipping into distilled water, and dried. To determine exhaustion, qualitatively, the solutions were brought again to 100 cc with water and the relative depths of color noted by the eye. There seemed to be nothing to be gained by making quantitative determinations of exhaustion. In all cases checks were run with dye solutions containing no sodium sulphate.

The first runs were made with Brilliant Blue Extra Green Shade (Elberfeld) because outside information had made it

seem probable that this dye would give abnormal results. The woolen strip in the most concentrated Glauber's salt solution (practically saturated) took up but little color from the bath. As the concentration of the Glauber's salt decreased to 0.5 gram per 100 cc, there was a continuous increase in the depth of the color of the wool, but beyond this point there was no marked change. The bath containing 0.5 gram  $\text{Na}_2\text{SO}_4 \cdot 10\text{H}_2\text{O}$  per 100 cc seem to dye more evenly than the more dilute solutions. The degree of exhaustion of the baths varied continuously, increasing with decreasing concentration of sodium sulphate.

With Safranine the gradation is even better and can be followed through the whole series. The strips dyed in the more concentrated solutions are the darkest and those in the most dilute solution the palest. The order is the reverse of that with Brilliant Blue, just as it should be. The degree of exhaustion of the baths also varies continuously, being greatest in the solutions with high concentrations of Glauber's salt and least in the dilute solutions.

With Croceine Scarlet the dyeing was more intense and the degree of exhaustion greater as the concentration decreased from 4 grams Glauber's salt per 100 cc. The baths containing 16 grams and 8 grams per 100 cc did not fall in line; but there was also a distinct color change in these two cases, so that it is probable that there had been an actual change in the dye.

With Benzopurpurine and wool there was very little difference in shade with varying concentration of sodium sulphate, though dyeing took place more evenly in the solutions containing little or no sodium sulphate. In spite of this, distinctly abnormal results were obtained as to the degree of exhaustion of the baths. Those containing 16 grams and 8 grams per 100 cc were almost colorless, with a colored precipitate in the bottom of the flask. The apparent degree of exhaustion was next greatest in the bath containing 4 grams  $\text{Na}_2\text{SO}_4 \cdot 10\text{H}_2\text{O}$  per 100 cc. This was followed by the bath containing no sodium sulphate. The 2-gram bath was more colored and the 1-gram bath was the most strongly colored

of all. A second run with new solutions gave the same result. Since the difficulty was evidently due to the formation of colored precipitates, the woolen strips were omitted and fresh solutions of the dye were boiled in presence of varying amounts of sodium sulphate. In each case heavy precipitates were formed, the supernatant liquid being only slightly yellowish. This is enough to account for the abnormal exhaustions.

When cotton strips were substituted for the usual woolen strips and were boiled in freshly prepared dye baths, very satisfactory results were obtained. The lightest strip was the one from the solution containing no sodium sulphate and there was a gradual increase in the darkening as the concentration of Glauber's salt increased. The results on exhaustion were more nearly normal than with wool, though there were colored precipitates at concentrations of  $\text{Na}_2\text{SO}_4 \cdot 10\text{H}_2\text{O}$  down to 2 grams per 100 cc; but the bath having no sodium sulphate was much more highly colored than those with increasing concentrations of this salt.

Glauber's salt is frequently employed in the dyeing industry to prevent a streaked appearance in the finished product and to cause the dye to penetrate farther into the fabric. The consequence is that the fabrics are dyed more evenly both on the surface and on the inside of the goods. That sodium sulphate causes a more even dyeing has been explained on the ground that the salt prevents the fabric from taking up the color so readily as it would otherwise do. Since the bath is not exhausted quickly, the dye has ample opportunity to come into immediate contact with all portions of the fabric before it is adsorbed; consequently, all parts are colored evenly when adsorption takes place. In order to test this hypothesis, two 100 cc solutions were made up of equal concentration as regards the dye; but one contained 1 gram  $\text{Na}_2\text{SO}_4 \cdot 10\text{H}_2\text{O}$  per 100 cc while the other did not. Both were heated to boiling, and six small woolen strips were placed simultaneously in each. At the end of 5, 15, 25, 35, 45 and 55 minutes, respectively, one strip was removed from each bath, washed, and

allowed to dry. An inspection of the strips gave qualitative information as to the rate of adsorption in the two baths.

With Acid Violet the color of the samples deepened with the time of immersion up to 45 minutes, after which there was no appreciable change because the baths were nearly exhausted. The exhaustion was greater in the bath containing no sulphate and the samples from this bath were always slightly darker than the corresponding ones from the bath containing sulphate. Though the sulphate cuts down the rate of adsorption, it also cuts down the total amount of dye adsorbed. The same effect was obtained with Acid Green, so that the usual explanation for the action of sulphate is not entirely correct.

As a preliminary to experiments on mordants, some experiments were made with lakes, prepared by precipitating a mordant in presence of the dye and in the absence of the fabrics. Aluminum hydroxide was precipitated from the sulphate solution by means of sodium hydroxide. This, of course, carries down some sodium sulphate. Aluminum hydroxide was precipitated from aluminum acetate, not necessarily in solution, by means of sodium hydroxide. A tannin lake was obtained by the action of tartar emetic on a tannic acid solution in the presence of ammonium chloride.

The first lot of alumina lakes were prepared by dissolving 8 grams aluminum sulphate in 50 cc water, adding enough dye to give the solution a faint color, and just precipitating all the alumina with caustic soda. The mixtures were allowed to stand in cylinders until the precipitate settled so that one could be certain whether the supernatant liquid was colorless or not. Alumina does not decolorize solutions of the following dyes completely: Fast Green; Acid Green; Croceine Orange; Fast Blue; Emerald Green; Victoria Blue; Thioflavine; Chrysoidine; Safranine. Alumina takes out nearly all the color from Alkali Blue and decolorizes a dilute solution of Acid Violet. A dilute solution of Alizarine is decolorized completely, a pink lake being formed. When a more concentrated solution is used, the color is not taken out so completely but the lake is dark

red. Solutions of Alizarine Green, Benzo Orange, Alizarine Orange, and Coeruleine decolorize well. A very dilute solution of Alkali Blue decolorizes completely. With Alizarine Black the supernatant liquid is somewhat yellowish; but otherwise this dye is very satisfactory. Solutions of Alizarine Blue and of Anthracene Chrome Blue are not decolorized satisfactorily by alumina. Chromium hydroxide is intended to be used as a mordant with Anthracene Chrome Blue; but no attempt was made to determine the behavior of the chrome lake. To a dilute solution of Alizarine Blue 60 cc of a water glass solution were added and the silicic acid then set free by hydrochloric acid. The silicic acid did not carry down the Alizarine Blue.

In cases where alumina causes little or no change in the color of the solution, it is impossible to say, by inspection whether the alumina is colored at all or whether the color that one apparently sees is due to the colored solution surrounding the precipitate. In cases of this sort the precipitate was filtered and washed. The dyes were added in small amounts to separate stand-glasses, each containing 50 cc water and 8 grams aluminum sulphate. The lakes were precipitated with NaOH as before and were allowed to stand for a week, after which they were filtered and washed with cold water, care being taken to note the appearance and color of the original lake, solution, and residue after filtration; also of the precipitate after washing, and of the wash water.

With Fast Green alumina seemed to carry down no color at all, the solution being apparently as intensely colored as before the alumina was precipitated. The filtered precipitate was almost white and one washing took out all the color. There is therefore no appreciable adsorption in this case, the slight color of the precipitate being due to mother liquor. Acid Green behaves like fast green. There is no perceptible decolorization of the solution and one washing leaves the alumina colorless. Acid Violet was carried down completely by alumina, as has been previously stated. When the pink lake was washed, the filtrate was colorless, so this lake is "fast" to cold distilled water. When a very dilute solution of

Alizarine Yellow is taken, the resulting lake does not color the wash water. Alumina is colored but slightly by Croceine Orange and one washing removes all the color.

Starting with a more concentrated solution of Fast Blue than usual, a light blue lake separated and the color of the supernatant liquid was less intense than before. When the bluish lake was washed, the color decreased in intensity and the wash water was distinctly blue. This seems to be a case where there is some adsorption but where the distribution coefficient is such that water takes out the dye gradually, the color not being fast. Emerald Green seemed to be taken up somewhat by alumina but the color washes out at once and the apparent color of the lake is therefore probably due to mother liquor. When alkali is added to Victoria Blue the color changes to a paler brown. A pale reddish brown lake is formed which does not yield any color to the wash water. With Thioflavine the alumina is so obviously colorless that the solution was not even filtered. With Chrysoidine the filtered lake appears slightly colored; but the first washing removes the tint. With Safranine the alumina seemed slightly colored but the first washing removed the color. This case differs from the preceding ones in that the filter paper was colored deeply by the original solution and prolonged washing did not remove all of the color though it did take some of it out. Of course this is not specially surprising because Safranine is used as a stain in histological work. It makes a very good experiment however. Bits of clean filter paper were next shaken up with some of the unwashed, slightly colored alumina and with pure water in an Erlenmeyer flask. The alumina was decolorized, part of the color going to the filter paper and part to the water. This is what one would expect because the water would wash the color out of the alumina while the filter paper would take up its proportion from the water. With aluminum sulphate we are precipitating alumina from a soluble salt. It seemed worth while to see what would happen if one started with the sparingly soluble aluminum acetate. With this salt it would be possible to add calcium acetate if desired, and the presence

of a calcium salt is considered essential when dyeing with alizarine. A dilute solution of the dye was made and a 30 cc portion was placed in each of two cylinders. To each solution was added 0.5 gram solid aluminum acetate (no analyses made). To one of the solutions was added as much solid calcium acetate as would go on the tip of a small knife blade. The mouths of the cylinders were closed with rubber stoppers and the mixtures were shaken thoroughly. Caustic soda solution was added, a little at a time, until no undecomposed aluminum acetate could be seen after shaking. An excess of alkali must not be added or the alumina will go into solution. The cylinders were allowed to stand until the lakes had settled. With Fast Green the lake settled rapidly in the cylinder to which calcium acetate had been added. The alumina was colored a deep green but there was some color in the supernatant liquid. The precipitate settled in the course of a few hours in the cylinder containing no calcium salt. A good deal of color was carried down by the alumina but not so much as when the calcium salt was added. It is interesting to note that alumina prepared from aluminum acetate carries down much more color than alumina prepared from a sulphate solution.

With Acid Green as dye, the lake settled at once in the solution containing lime; but did not take down all of the color. In the solution containing no calcium salt, the lake settled over night. It seemed to be more deeply colored than the corresponding lake containing lime, thus reversing the phenomena obtained with Fast Green. So far as qualitative tests go Acid Green is adsorbed to a lesser extent than Fast Green. With Acid Violet 3R both lakes carried down practically all the color. The only apparent difference is that the lake settled almost immediately in the solution containing lime and much more slowly in the other case. With Croceine Orange the settling was more rapid in the solution containing lime and nearly all the color was carried down. The exhaustion of the bath was not nearly so complete in the solution containing no calcium salt. Both the solutions of Alizarine

Yellow changed to red on the addition of caustic soda but returned to their former color when the base had reacted with the aluminum acetate. In both cases the lake removed nearly all the color; so that the only noticeable difference was the rapidity of settling when calcium acetate is present. The solutions of Fast Black O (Meister, Lucius and Brüning) turned pale pink when alkali was added and then did not turn back completely, probably because a slight excess of base was present. The precipitate settled at once in the solution containing lime and the lake appeared to carry down all the color. The precipitate in the other solution settled over night and carried down most, but not all, of the color. With Emerald Green and Chrysoidine, practically no adsorption took place from either solution. The presence of lime caused a more rapid precipitation. The solutions of Victoria Blue turned pink on addition of alkali. The lakes were reddish brown and removed practically all the color.

The increased adsorption of the acid dyes, Fast Green, Acid Green, Acid Violet, Croceine Orange, Alizarine Yellow, and Fast Blue when no sulphate is present, is undoubtedly in line with the action of sodium sulphate in preventing these dyes from being taken up by wool. It had been hoped that sodium sulphate would cause the basic dyes, Emerald Green and Chrysoidine, to be taken up more readily by alumina; but this seems not to be the case. The cases would be more nearly parallel if we had a basic dye which was adsorbed appreciably by alumina. It is conceivable that the sodium sulphate acts as it should but that the difference falls within the limit of experimental error. This is a plausible assumption because it has been found that a saturated solution of sodium sulphate will not strip alumina lakes of Alizarine or Alizarine Black when these are prepared from aluminum sulphate solution. The rapid settling of the lake in presence of calcium salt is in line with the general behavior of colloidal suspensions.

It is worth noting that the apparent volume of the precipitate was always greater in the solutions containing calcium salts than in the corresponding solutions containing none.



There are several possible ways of accounting for this. The precipitate might be less dense and therefore more bulky in the one set of cases; the precipitate might actually be heavier, owing to the presence of calcium hydroxide; or the precipitate might actually be heavier owing to more complete precipitation of the alumina. The third assumption does not seem probable because the supernatant liquid does not seem less clear in one case than in the other. While the second assumption is undoubtedly true, so little calcium acetate was taken that it does not seem probable that the calcium hydroxide could account for the difference. It seems more plausible that the rapidly coagulated gel contains more water than that which has precipitated slowly. As this is really a problem in general colloid chemistry rather than in the special subject of dyeing, no work was done on this point, interesting though it is.

The wide use of tannin with potassium antimony tartrate in connection with the mordanting of basic dyes upon cotton suggested the preparation of tannin lakes with basic and acid dyes. Accordingly, cylinders containing about 50 cc each of dilute solutions of various dyes were arranged in a row; to each cylinder was added about a heaping tablespoonful of tannin. The cylinders were shaken thoroughly to cause apparent solution of the tannin, and 5 cc molar ammonium chloride added to each stand-glass. The lakes were then precipitated by adding sufficient tartar emetic solution, little by little. The precipitates were allowed to settle for 2 hours though this was longer than was necessary. Experiments were made with the acid dyes, Fast Green, Acid Green, Acid Violet, Croceine Orange, Alizarine Yellow, and Fast Blue; and with basic dyes, Emerald Green, Victoria Blue, Thioflavine, Chrysoidine and Safranine. In every case the precipitate carried down practically all the color regardless whether the dye was a basic or an acid one. These lakes did not bleed when washed with water. Unless ammonium chloride is added no precipitate forms and we are apparently dealing with a colloidal solution of the lake analogous to some of the

writing inks. It makes no difference, however, whether the ammonium chloride be added before or after the tannin and the tartar emetic solutions are mixed. If added after the mixing, the ammonium chloride causes the precipitation of the lake.

Experiments were next made on cotton mordanted with tannin, with and without tartar emetic. Cotton strips were boiled for 1 hour with tannin and water, were dried, and then were treated with solutions of basic dyes. Thioflavine dyed the cotton well and Victoria Blue very poorly; Emerald Green gave a good green; Chrysoidine, a brilliant orange and Safranine a deep red. The strips were boiled with distilled water for an hour to fade them if possible. The strip dyed with Emerald Green faded a great deal, the cloth becoming a light green and the solution turning *pink*. The pink color being unexpected, the solution was decanted and was used to dye wool and cotton. Wool dyed slightly green, leaving the solution still pink; while the cotton turned greenish with a pink tinge, the solution being then very pale pink in color. To determine whether the pink color was due to a reaction of the dye with tannin, a solution of the two were boiled without any cotton being present. The color remained green and no change to pink could be detected. The strip dyed with Thioflavine bleached a great deal, the solution becoming colored slightly yellow, while a flocculent, yellow precipitate formed in the bottom of the beaker. This precipitate is undoubtedly a thioflavine lake. The strip dyed with Chrysoidine faded considerably, the water taking on a deep orange color. The strip dyed with Safranine also faded a great deal, the solution becoming deep red. The strip dyed with Victoria Blue faded but little and imparted but a slight color to the water; but this is probably due in part to the fact that the cotton had only taken up a little of the dye originally.

To study the mordant action of tannin and tartar emetic combined, cotton strips were soaked in a cold tannin solution, dried, passed through a solution of potassium antimony tartrate, dried, and then dyed in a neutral bath. The strips

were dried, and a small sample cut from each to act as a check. The strips were then boiled with water for 4 hours to make them fade. Emerald Green and Victoria Blue did not dye smoothly, the cloth being spotted. The spotting with Emerald Green seems to be due to air bubbles adhering to the fabric and keeping dye solution from wetting it completely. Fast Green and Acid Green dyed well but faded considerably; Acid Violet and Croceine Orange dyed very well but faded out nearly completely. Fast Blue dyed well, but faded almost completely. Alizarine Yellow did not dye a deep shade but did not fade much. It is worth noting that while Alizarine Yellow is fairly fast when mordanted with tannin and tartar emetic, it does not dye cotton readily. The dye seems to be adsorbed slowly; but the mordant holds it well after it has once soaked in.

Emerald Green dyed a fairly good color but spotted; it did not fade. Victoria Blue dyed very poorly but did not fade. Thioflavine, Chrysoidine, and Safranine dyed beautifully and were fast. There is very little fading with the basic dyes while the acid dyes are not fast with the exception of Alizarine Yellow.

Since soap is used to some extent as a mordant, strips of cotton were boiled for an hour in a concentrated soap solution made from yellow laboratory soap. The strips were allowed to dry and were then dyed in a neutral bath. Checks were run with strips which had not been treated with soap. The dyes used were Emerald Green, Victoria Blue, Thioflavine, Chrysoidine, and Safranine. In every case the strips which had not received the soap treatment dyed much deeper than the others. When boiled with water, the color was much faster in the strips which had received the soap treatment. After 16 hours' boiling with water, the strips were still fading a little and there was very little difference between the two sets. The experiments, like the one with tannin alone, were not quite fair from the dyer's point of view because soap is not ordinarily used without a fixing agent. Another set of runs was therefore made, in which the cotton strips were boiled

for 1 hour in a dilute soap solution and then dried. They were next placed for 30 minutes in a cold solution of soda alum, after which they were allowed to drain and dry partially for an hour. They were boiled for an hour in a neutral dye bath. As before, checks were run with cotton strips which had not been treated with soap and with alum. The dyes used were the same as before. In each case the treated strip took up more color than the untreated strip. When boiled with water twice for an hour each time, the mordanted strips, which had been dyed with Emerald Green or Victoria Blue, faded very slightly if at all, while the untreated strips faded considerably. With Thioflavine and Chrysoidine the untreated strips did not fade so much as did the untreated dyed with Emerald Green or Victoria Blue; but they faded much more than the corresponding, mordanted strips. The sodium oleate, which is the important item in the soap, apparently cuts down the amount of dye which the cotton will take up; but what dye is taken up becomes practically fast to boiling water.

The general results of this paper are as follows:

1. Acid dyes should be taken up more completely in an acid solution than in a neutral one and least of all in an alkaline solution, while the reverse should be true with basic dyes. Good gradations can be obtained on wool with Acid Green and Emerald Green; on cotton with Fast Green and Safranine.

2. Marked differences between the dyeing in acid and alkaline solutions can be obtained on wool with Fast Green, Fast Blue, Acid Violet, Croceine Orange, Crystal Ponceau, Chrysoidine, Safranine, and Methylene Blue; on cotton with Acid Violet, Croceine Orange and Emerald Green.

3. Addition of sodium sulphate should cut down the adsorption of acid dyes and increase the adsorption of basic dyes. Excellent results are obtained on wool with Acid Green, Fast Blue, Croceine Orange, Victoria Blue, Chrysoidine and Safranine; on cotton with Benzopurpurine.

4. The effect of continuously varying concentrations of sodium sulphate is shown well on wool with Brilliant Blue and Safranine; on cotton with Safranine.

5. Alumina, precipitated from an aluminum sulphate solution, carries down practically no Fast Green, Acid Green, Croceine Orange, Emerald Green, Thioflavine, Chrysoidine, or Safranine. There is a slight adsorption of Fast Blue and Victoria Blue, but not enough to decolorize even a fairly dilute solution.

6. Alumina, precipitated from an aluminum acetate solution adsorbs Fast Green, Acid Green and Croceine Orange considerably but not Emerald Green or Chrysoidine. Presence of sulphate decreases the adsorption of the acid dyes by alumina as well as by wool.

7. When calcium acetate is added to the aluminum acetate solution, the alumina carries down more Fast Green and Croceine Orange but less Acid Green. In all cases the lake settles faster in the solution containing lime.

8. Alumina, precipitated from an aluminum sulphate solution, decolorizes dilute solutions of Alizarine, Alizarine Green, Benzo Orange Coerulein and Acid Violet practically completely. Alumina, precipitated from an aluminum acetate solution, decolorizes more concentrated solutions.

9. Tannin, tartar emetic and ammonium chloride carry down Fast Green, Acid Green, Acid Violet, Croceine Orange, Alizarine Yellow, Fast Blue, Emerald Green, Victoria Blue, Thioflavine, Chrysoidine, and Safranine practically completely. The presence of ammonium chloride is essential to precipitate the hydrosol. These lakes do not bleed when washed with water.

10. When cotton is mordanted with tannin and tartar emetic, it dyes well with Thioflavine, Chrysoidine, Safranine and Alizarine Yellow; the colors stand washing with water. The cotton dyes well with Fast Blue, Fast Green, Acid Green, Acid Violet, and Croceine Orange but the colors fade when washed with water.

11. When cotton is treated with soap, it takes up Emerald Green, Victoria Blue, Thioflavine, Chrysoidine and Safranine less completely than the untreated cotton; but the color washes out less rapidly.

12. When cotton is treated with soap and alum, it takes up Emerald Green, Victoria Blue, Thioflavine and Chrysoidine less completely than the untreated cotton. With Emerald Green and Victoria Blue, there is only a slight fading on washing with water; with the Thioflavine and Chrysoidine there is considerable fading but not so much as when no alum is used.

This investigation was suggested by Professor Bancroft and has been carried on under his supervision.

*Cornell University*

## MERCURIC OXIDE

BY GUY B. TAYLOR AND GEORGE A. HULETT

The atomic weight of mercury as at present accepted, is based on the analysis of the chloride and bromide, salts of quite similar character. Confirmation from other classes of compounds is desirable. From our work on the dissociation of *mercuric oxide*<sup>1</sup> we have become convinced that this compound can be prepared in a high state of purity by the direct union of mercury and oxygen. Mercury can probably be prepared purer than any other single substance<sup>2</sup> and electrolytic oxygen leaves little to be desired. In the previous work the oxide was made by heating the two elements together in sealed tubes of about 200 cc capacity. From so small a volume of oxygen but little of the oxide could be produced at each heating, and part of it adhered so tightly to the walls of the tube, that scraping was necessary for its removal, causing traces of silica to occur in the product. It was also difficult to open the tubes with their high vacua without introducing bits of broken glass.

With the apparatus sketched in the accompanying figure (Fig. 1) we were able to heat the two elements together and supply the oxygen under pressure as fast as it was used up. Tube A, capacity about 250 cc was half filled with mercury and placed in an electric furnace. The two traps T and T' contained mercury. When oxygen was compressed in the cylinder C, by pouring mercury into the separatory funnel, the gas bubbled through the mercury in T' and into the reaction tube A. At the same time the mercury in trap T rose in the left arm, preventing pressure being put upon the other parts of the apparatus. The oxygen cylinder C could be refilled at any time by closing the cock of the funnel and drawing out the mercury from the bottom. The gas entered from the generator by bubbling through trap T and trap T'

<sup>1</sup> Jour. Phys. Chem., 17, 565 (1913).

<sup>2</sup> Hulett: Phys. Rev., 33, 310 (1911).

prevented the release of the pressure in the reaction tube A. At the beginning the air was pumped out through tube B and then this tube sealed off.

The oxygen was generated electrolytically in a type of generator (E, E) that has given good results in this laboratory. It consisted of two cylindrical vessels, capacity about two liters each, connected at the bottom by a short piece of wide glass tube with ground joints. The apparatus could not be made in one piece, but the joints were well ground and held tight without lubrication. Tubes for leading off hydrogen

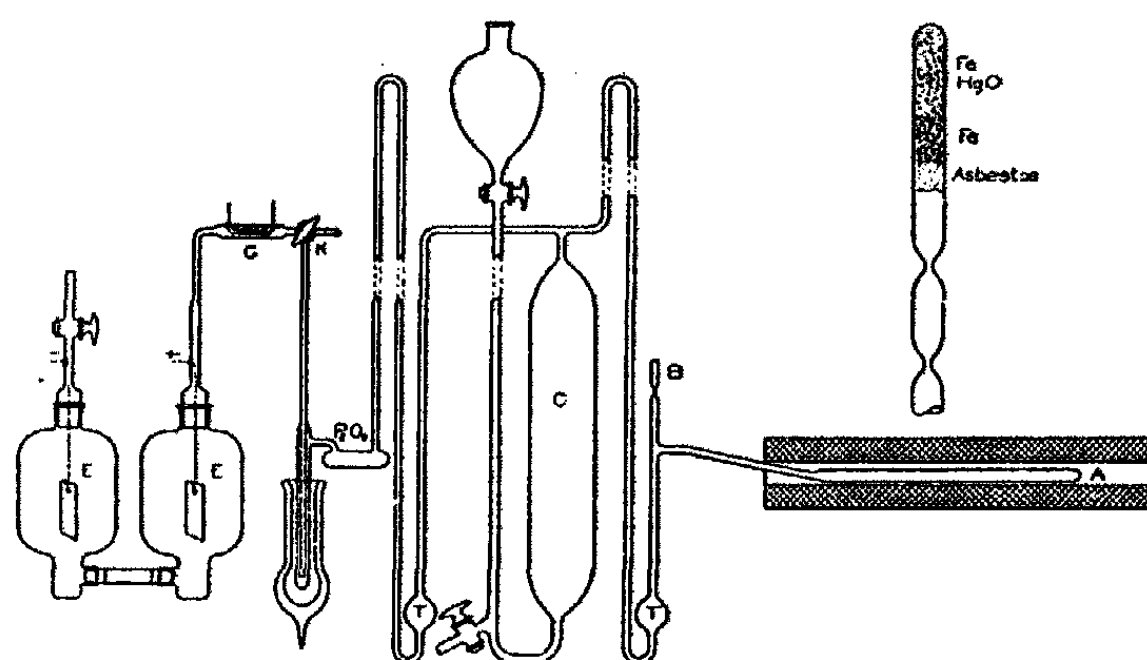

Fig. 1

and oxygen were connected at the top of each vessel by means of ground connections made gas tight with a trace of marine glue. Platinum wires sealed into tubes just above the ground joints carried the platinum gauze electrodes. For electrolyte we used a 30 percent solution of Kalilbaum's best potassium hydroxide, kept permanently free from carbonate by an excess of barium hydroxide. The oxygen was passed over an electrically glowed platinum spiral, G. Moisture was removed by freezing out or passing over phosphoric anhydride as indicated in sketch. The apparatus serves equally well for hydrogen.

All parts of the apparatus were glass and only one stop-



cock with which the oxygen came in contact was necessary. This was well ground and required only a trace of lubricant. At first we used syrupy phosphoric acid, but since this required frequent renewing, and it was necessary to operate the apparatus continuously for many days, we later substituted a good quality grease. Chance of contamination of the oxide in the reaction tube from this source is too remote for consideration.

Four times distilled mercury was heated in the reaction tube A at  $420 \pm 10^\circ \text{C}$  under an oxygen pressure of 2-3 atmospheres continuously for from five to seven days. Only that portion of the oxide floating on the surface of the metal or falling loosely from the tube was taken while that adhering to the tube was rejected. The yield was 10-15 grams HgO per run. The reaction is so extremely slow and the yield so small that our supply of oxide has necessarily been limited. To emphasize this difficulty it may be remarked in passing that the reaction tube exploded on three separate occasions after the run had been going several days.

The oxide was finally freed from all traces of uncombined metal by heating to  $400^\circ$  in a rapid stream of oxygen under a pressure of one atmosphere. The gas was taken from a cylinder furnished as pure oxygen by the S. S. White Dental Mfg. Co. and dried by sulphuric acid, soda lime, and calcium chloride. At  $400^\circ \text{C}$  the rate of decomposition of the oxide is insignificant and the vapor pressure of mercury something over two atmospheres, so we concluded that any mercury mechanically enclosed by the crystals would be expelled. The oxide was then bottled and kept in a desiccator until used.

#### **Analysis of the Oxide**

The principle of the analysis consisted in reduction of the oxide by metallic iron and weighing the mercury as metal. The ground oxide was weighed in a hard glass tube about 200 mm long and 7.5 mm internal diameter, closed at one end. This was thoroughly mixed in the tube with about twice its volume of finely divided metallic iron. This mixture was

covered with a layer of iron powder and the whole held in place by an asbestos plug. The tube was then constricted in two places, the air exhausted to a pressure of 0.1 mm or less with a mercury pump, and sealed off at the constriction nearer the pump. The decomposition was effected by putting the inverted tube in an electric heater with its empty end protruding below and remaining at room temperature to condense the evolved mercury. The temperature was raised slowly and held at 350–375° for 2 or 3 hours, or until practically all the mercuric oxide had been reduced. Then the temperature was raised to about 600° C and held there 24 to 36 hours longer to insure complete decomposition. During the last half hour, the protruding end of the tube where the mercury was condensed was cooled to 0° with ice.

Whether there is enough iron in actual intimate contact with the oxide to effect its complete reduction is immaterial, since the iron oxide formed rapidly catalyzes the dissociation into mercury and oxygen, but the total iron present must be sufficient to take up all the oxygen liberated in order to prevent reoxidation. At the end of the experiment the tube was cut open and the mercury transferred as a single globule to a porcelain crucible and weighed. The metal obtained in this way required no washing or drying, an operation involving some difficulties as has been pointed out by Perdue and Hulett<sup>1</sup> and Easley.<sup>2</sup> The finely divided iron was obtained by reduction of Baker's "analyzed" ferric oxide in pure, dry hydrogen. By the above method the following results were obtained.

The weighings were made by the method of substitution, using a Ruprecht balance capable of giving an agreement of 0.02 mg on consecutive weights. This balance was kept in a room where temperature and humidity were under control. Ample time was always allowed for temperature differences to adjust themselves after each opening of the balance case. Carefully calibrated weights were used and vacuum correc-

<sup>1</sup> Jour. Phys. Chem., 15, 147, 155 (1911).

<sup>2</sup> Jour. Am. Chem. Soc., 32, 1117 (1910).

tions applied, 0.03 mg per gram HgO and 0.055 mg per gram Hg.

Sample	Wt. HgO	Wt. Hg	Percent Hg
W	2.98464	2.76390	92.604
W	3.61841	3.35066	92.601
A	3.82184	3.53923	92.606
A	3.40356	3.15185	92.605
A	3.80726	3.52567	92.606
B	4.56858	4.23065	92.603
C	5.42945	5.02819	92.609
D	2.38313	2.20681	92.602
D	3.76766	3.48933	92.612

General mean 92.6053  $\pm$  0.0008

Then for O = 16 Hg = 200.37  $\pm$  0.025.

The constancy of the results obtained is all that could be desired; the probable error of a single determination of the percent Hg in HgO is  $\pm$ 0.002 percent and of the average percentage  $\pm$ 0.0008 percent. Now mercury oxide was weighed as the starting point and the oxygen determined by difference, not a standard method for an atomic-weight determination; nevertheless, the results are so consistent that the calculated atomic weight of mercury 200.37 (O = 16) shows a probable error of only  $\pm$ 0.025, which should give us the first decimal place and a good idea of the second, provided there are no constant errors.

The manipulation and method were tested by weighing pure mercury into a tube, adding the iron, evacuating, and proceeding as in the analysis. This would determine whether any mercury was retained by the iron or lost by faulty condensation. No loss could be detected. The HgO was prepared from direct union of oxygen and mercury, using only the purest materials with no contact with other substances. The oxide could include some mercury, but subsequent heating in a current of oxygen to 400° seemed to entirely eliminate this source of error, and as the calculated atomic weight is smaller than the latest determination, this point seems to be

above criticism; that the oxide was not completely decomposed is improbable for the heating in contact with the catalyzer, ferric oxide, at  $600^{\circ}$  was always 24 hours and several of the determinations 36 hours, with the same results.

The accepted atomic weight of mercury is based upon the excellent work of Easley<sup>1</sup> and of Easley and Brann.<sup>2</sup> These investigators worked with the chloride and bromide. From their published results we have calculated the following:

Hg : HgCl <sub>2</sub> ( 6 determinations)	73.8833	$\pm$ 0.0007%	=
		200.621	$\pm$ 0.0058
HgCl <sub>2</sub> : 2 AgCl ( 6 determinations)	94.7177	$\pm$ 0.0023	=
		200.617	$\pm$ 0.0067
HgBr <sub>2</sub> : 2 AgBr (11 determinations)	95.9697	$\pm$ 0.0013	=
		200.622	$\pm$ 0.0052

As far as the experimental results are concerned, this work should locate the atomic weight of mercury at 200.62, with the second decimal place quite certain, provided there are no constant errors. The mercury was weighed direct and the chlorine determined as silver chloride, the results agreeing so closely that one is inclined to consider the methods without sensible error and the percentage of mercury in the mercuric chloride used as 73.8833 percent. If this salt was pure we are justified in the above value for the atomic weight and the bromide results give added confidence.

Our result, 200.37, shows a marked deviation from this value but our method was so simple and direct that we place a great deal of confidence in 92.605 percent being the percentage of mercury in our oxide. In preparing the oxide everything was excluded but oxygen and mercury with no contact with other substances. Since there appears to be too little mercury, inclusion of the metal is not to be considered, nor oxygen as an impurity in solution in HgO. But if some higher oxide is capable of existence and is soluble in HgO, it might be expected to be present, for in the system oxygen and mercury in equilibrium with both elements in

<sup>1</sup> Jour. Am. Chem. Soc., 31, 1207 (1909); 32, 1117 (1910).

<sup>2</sup> Ibid., 34, 137 (1912).

excess, every possible combination of Hg and O must have been present while the HgO was forming. Bredig and Weinmayr<sup>1</sup> have noticed a periodic catalysis of the decomposition of hydrogen peroxide in solution by metallic mercury. Antropoff<sup>2</sup> has shown that this is due to the alternate formation and shearing away of a film of a mercury compound on the surface of the metal, which he has isolated and identified as HgO<sub>2</sub>. A very slight amount (0.13 percent) of such a peroxide in our preparation would account for our low value, and would be exceedingly difficult to detect if present as solid solution. The results obtained from this analysis of our mercury oxide seem to us to call for a further investigation of the atomic weight of mercury.

*Laboratory of Physical Chemistry,  
Princeton, October, 1913*

---

<sup>1</sup> *Zeit. phys. Chem.*, **42**, 601 (1903).

<sup>2</sup> *Ibid.*, **62**, 513 (1908); *Jour. prakt. Chem.*, **77**, 273 (1908).

## ON THE MECHANICAL PROCESSES OF COMBINATION

BY NATHANIEL T. BACON

Whenever a chemical reaction occurs, evidently at the absolute point of combination there must be brought into simultaneous contact sufficient of all the elements involved to make up the resulting combination. When all or part of the materials involved in the chemical changes are gases, which by their nature are discontinuous, so that there is theoretically little probability of simultaneous presence with the other materials of more than a single molecule of gas at the critical point, the process by which combination can occur becomes complicated and especially so whenever a single molecule of a gas thus entering into combination is insufficient to satisfy the requirements of equilibrium with a single molecule of any other of the constituents.

By theory there will never be more than momentary contact between a gaseous molecule and any other, solid or gaseous. It will be rare, therefore, that two gaseous molecules impinge simultaneously on any other, which goes far to explain why reactions involving concurrence of three molecules are hard to carry on, and those involving more than three are very rare; as osmotic pressures show that movements in solutions are akin to those in the gaseous state.

The only exceptions to the rule of only momentary contact for gases seem to be those due to absorption and adsorption, and very likely even the phenomena observed in such cases are not really exceptions, but merely the result of transformation of an infinitesimal amount of the gas in question to the liquid state, forming a film perhaps not one millionth of a millimeter thick on exposed solid surfaces, though perhaps not covering them entirely. Experiments on the increase of weight and temperature of platinum sponge when exposed to hydrogen indicate that this most volatile

of all well-known gases is there reduced to a liquid condition, and, if so, it is a less violent assumption for any other gas.

My theory of this action is based on the hypothesis of imperfect elasticity for at least certain molecules. The ordinary assumption is that all molecules are perfectly elastic. This I should be inclined to question merely from the divergences found in practice from Boyle's law concerning the expansion of gases. This theory really goes back of the molecular to the atomic condition, and assumes the multiplicity of parts of the atom. Probably this no longer requires proof, but if some are not satisfied, evidence for it appears in the different lines of the spectra of all substances, showing (as the spectra are atomic and not molecular phenomena, it making little difference how the atoms are combined) that different parts of the atom are vibrating in different periodic times. If this is the case, even with molecules containing only two atoms, there is room for deformation by distortion of the individual atoms, and the heavier the atom the greater the apparent opportunity for this. As complicated molecules also give opportunity for direct distortion, the heavier the molecule, the less perfect its elasticity is likely to be, which also accords generally with the divergencies from Boyle's law, and some further evidence in favor of this has been found in certain experiments made at Harvard under 40000 atmospheres of pressure, which were unpublished in 1911, and of which I have been unable since to find any trace in the Abstracts of the American Chemical Society.

The theory offered is that when imperfectly elastic molecules collide, they do not recoil with the same virtual velocities as before, but parts of their kinetic energies are converted into heat by the work done in distorting the molecule, and when one of the molecules is in the solid or liquid form (which allows for removal, by conduction, of part of the heat generated) the loss of velocity is not fully compensated by increase of temperature of the migratory molecule (which otherwise would increase its velocity to the original speed). The loss of velocity may thus be carried to the point where a film of such

molecules forms more or less completely over the solid nucleus, a limit being reached when the temperature of the solid and surrounding film rises to the point of driving off a new molecule for each one that comes into this composite system. Such molecules having lost their migratory velocity but having an increased temperature would seem to correspond pretty closely to the case where a gas loses its latent heat of volatilization partially by conduction and partially by increase in temperature, as occurs when a gas is condensed in a compressor cylinder, thus making it not improbable that these films are in liquid condition, and that the calorific transaction in driving off a different molecule, to balance a new one retained, consists in furnishing to the one volatilized the latent heat lost by that retained. This action is very similar to the galvanic transfer, by which frequently erosion takes place by a solution, not at the point where the oxygen reaches the body affected, but at some totally different place, where either greater purity of the substance or some other determining cause establishes a polarity.

In accordance with this hypothesis the films gathering thus around a solid particle would be likely to be mainly if not wholly of some particular constituent in a medium consisting of a mixture of gases.

It is a corollary of the discontinuous nature of gases that their conditions of combination relate only to the molecules actually coming into contact. It is well established, both theoretically and by observation, that certain molecules in a gaseous mixture have higher velocities and therefore higher temperatures than the general average, which alone we are able to determine with accuracy; and as what probably rules is the average temperature of the system of molecules coming into contact, it is impossible to determine the exact temperature at which ignition begins, for if two molecules of higher average temperature (one might be much warmer than the other) than the general average come into contact and thus combine, the heat generated by their combination is thus sufficient to drive up the temperature of the general



average, with the probable result of causing general combination in the neighborhood if the general temperature is anywhere near the ignition point.

At best our knowledge of temperatures of gases is imperfect, as these can only be determined by means of solids or liquids with which the gases are in contact, and as we have just seen, the parts of them in immediate contact with solids are probably much denser and much warmer than the general mass, both of which conditions are conducive to chemical combination; so that the probability is strong that the real temperature of initial combination is above that of the mass of gas in which combination occurs, merely on account of these surface phenomena, even if not on account of the difference in velocities of migrating molecules. Again, the direction of motion of impinging molecules is probably an important factor, for two molecules striking head on with high opposed velocities would generate far more heat and reach a far more intimate contact than if moving in nearly parallel paths in the same general direction and with only slightly differing velocities, though possibly part of this difference might be offset by the greater duration of contact than in the case of molecules moving in opposite directions.

From these considerations it would appear that the temperature of initial combination should be independent of the presence or absence of neutral molecules in the case of simple reactions, but this must not be confused with the temperature of propagation, which, of course, would be much higher with materials diluted by inert gases than with pure gases. Also we can see to how great an extent these temperatures would be affected by the nature of the containing vessel, or of whatever other solid might be present, as one might lead to far greater surface condensation of the nature of adsorption than would be the case with another. Moreover, the presence of even small quantities of other gases, adsorption films of which might furnish auxiliary quantities of the constituents necessary for completing equilibrium, should play a very important part in aiding combination in

cases where otherwise it would be difficult to account for the simultaneous presence of sufficient molecules to complete the reaction which takes place. Of course in some cases the process might be by several steps, but in other cases there would seem to be normally otherwise no method by which even a first step could be accomplished.

We are all familiar with one kind of segregation of this type, namely, the moisture which gathers on glass surfaces, and this has the advantage further of illustrating the selective power of both gases and solids, for it is especially aqueous vapor that is condensed by glass out of a mixture of gases, and especially glass which gathers moisture from the same atmosphere out of a mixture of solids. The difficulty of obtaining an accurate weighing of a dry glass beaker, owing to its adsorption of moisture, is familiar to every chemist, while a platinum crucible will remain much more nearly constant for the same surface exposed in a damp atmosphere.

As a simple case let us consider the question of the combination of oxygen and carbon. By the simplest of all the hypotheses so far presented the carbon molecule must contain two atoms, and it is generally considered to contain a multiple of two. Each of these has a valence of 4, and accordingly combustion to  $\text{CO}_2$  calls for more than one molecule of oxygen unless part of the molecule of carbon is left in some other condition than that of a complete molecule. Two molecules of gaseous oxygen are not likely often to strike simultaneously on the same molecule of carbon. On the other hand, a liquid in contact with the carbon could furnish oxygen from several molecules at once, so that the presence of an adsorption film of any liquid from which carbon could take oxygen ought to facilitate the reaction.

H. B. Dixon<sup>1</sup> has shown that pure charcoal ignites in oxygen with  $\text{H}_2\text{O}$  present between  $450^\circ$  and  $500^\circ$  but that without  $\text{H}_2\text{O}$  a higher temperature is needed, and that more CO was produced than with  $\text{H}_2\text{O}$  present, and that there was

<sup>1</sup> Dixon and Coward: *Jour. Chem. Soc.*, 95, 514 (1909).

a considerable residuum of oxygen even with long exposure to carbon at a red heat, and that the mass did not glow without water vapor present, probably indicating slow distribution of the heat.

He also found that perfectly dry  $\text{CO}_2$  was not reduced by charcoal at a red heat, though it went rapidly with a little water vapor present. It even seems probable that absolutely dry oxygen would not attack charcoal at a red heat.

On the assumption either that the carbon molecule contains more than two atoms, or that  $\text{CO}_2$  is the primary product of combustion, we can see how greatly the reaction would be aided by the presence of adsorption films of aqueous vapor on the carbon. Water vapor is so enormously more condensible than oxygen that it is not difficult to imagine that even traces of it might have a tendency to form adsorption films on the surface of the carbon of a system, maintaining constantly in contact a certain quantity of oxygen capable of being delivered up to aid in the formation of  $\text{CO}_2$  whenever a molecule of free oxygen should impinge on the molecule of carbon. We are perfectly familiar with the reaction by which superheated steam is decomposed by incandescent carbon, and this is just the condition which would obtain under the hypothesis just shown. Moreover the hydrogen set free by the decomposition of the aqueous vapor would thus form by itself a complete molecule in spite of its loss of oxygen, so that the system would remain in equilibrium.

The ignition temperature of CO seems to be considerably above that of carbon, which therefore seems to argue that  $\text{CO}_2$  is the primary product of normal combustion.

One other instance of what may be the effect of an adsorption film I will present, namely, that of the glowing of an ember before the bellows, where before it was slowly dying. As surrounded by the atmosphere theoretically it was in contact with oxygen sufficient to keep up combustion, but frequently we see it slowly go out. The ordinary explanation of this phenomenon is that the atmosphere conducts off the heat faster than combustion supplies it, but why is it then

that application of the bellows causes it to glow? If the former explanation were alone sufficient, the case would not be improved, for as much more air would be brought into contact with the ember to carry off the heat as there would be additional to sustain combustion. Is not the true explanation rather that the action of the bellows breaks up mechanically an adsorption film of  $\text{CO}_2$  which before covered the surface of the ember and was gradually chilling the system by convection?

Probably there is no such thing as conduction of heat by gases. These are essentially discontinuous and even heterogeneous as to temperature, certain molecules probably being hotter and moving at higher velocities than others of the same general mass, so that the transference of heat by means of gas, commonly referred to as conduction, should be more properly considered as convection, by which a molecule, coming into momentary contact with a hot solid, more or less perfectly assimilates the temperature of that solid (depending somewhat on the rapidity of conductivity of the solid), and then on impinging on any other molecule more or less perfectly equalizes its temperature with that of the other molecule in question, so that heat is transferred by gases through constant interchange of the charge, but not by conduction proper, which would seem impossible in discontinuous systems such as the true gases all consist of.

Will not the hypothesis here brought forward, of the auxiliary action of adsorption films account for many, if not all, of the phenomena which we now explain by the indefinite terms of catalytic action?

*Peace Dale, R. I.,*

*July 8, 1913*

## CHROMIC OXIDE JELLIES

BY E. H. BUNCE AND L. S. FINCH

When a solution of sodium silicate is acidified with hydrochloric acid, the solution usually solidifies more or less rapidly to a jelly. When caustic soda is added to a solution of chromic, ferric, cupric, or aluminum chloride we usually get a gelatinous precipitate which does not form a jelly. On the other hand, it is possible to obtain jellies of hydrous chromic, ferric, cupric, or aluminum oxides. At present there is no satisfactory theory to show why a gelatinous precipitate will form a jelly in one case and not in another. It is not entirely a question of high concentration, as von Weimarn<sup>1</sup> assumes, because Crum<sup>2</sup> claims to have obtained hydrous aluminum oxide in the form of a jelly when the solution contained one part of alumina in six hundred of water and one part of sulphuric acid in seventy-five hundred of water. As a preliminary to a theory, it seemed desirable to obtain some data as to the conditions under which one gets jellies of hydrous inorganic oxides. We began with the chromic oxide jellies which had previously been studied by Reinitzer,<sup>3</sup> from whom we quote:

"If a solution of chromic sulphate or chloride is mixed with an excess of sodium acetate and boiled, no deposit is formed even after hours of ebullition, however concentrated the solution, and however much sodium acetate is added. If the solution is boiled for a short time only, it takes a violet color on cooling. The solution of a chromic salt thus treated is found to have assumed decidedly new properties. Caustic alkalis, ammonia, ammonium sulphide and carbonate alkaline carbonates, sodium phosphate, baryta water, and barium carbonate, produce in the cold not the slightest turbidity, whether added in small quantities or in excess. Caustic

<sup>1</sup> *Zeit. Kolloidchemie*, 5, 122 (1909); 7, 157 (1910); 9, 25 (1911).

<sup>2</sup> *Jour. Chem. Soc.*, 6, 216 (1856).

<sup>3</sup> *Chem. News*, 48, 114 (1883).

alkalies and baryta change the color of the solution, at first to an olive-green, and then to an emerald-green, and after standing for twelve hours the liquid congeals to a green jelly. On adding ammonia no immediate change of color occurs; after about 48 hours the liquid is converted to a violet jelly. Ammonium sulphide and carbonate act in the same manner after the lapse of several days. If the mixture is boiled after the addition of the above-mentioned reagents, a precipitate appears sooner or later according to the strength of the alkaline solution and the quantity added; sodium phosphate alone causes no deposit."

A very satisfactory jelly can be obtained in the following way: Dissolve one part of chromic sulphate or chloride in about twenty of water. Add approximately one gram sodium acetate per 20 cc solution; boil for one minute and allow to cool. The solution is now violet in color. Add concentrated caustic potash (1 : 3) or soda until the solution is distinctly alkaline. The solution turns green and sets in 10-20 minutes to a stiff jelly. If ammonium hydroxide is added instead of sodium hydroxide, the solution becomes distinctly purple<sup>1</sup> and sets to a jelly inside of twelve hours.

The effect of varying the concentration of the chromium salt was next tried, keeping all the other conditions as nearly the same as possible. Caustic potash was added until the solutions were just alkaline to litmus paper. The concentrations varied from one of chromic sulphate in one thousand of water to one in less than nine of water. With solutions containing less chromic sulphate than one part in one hundred of water, no jelly was obtained but merely a viscous solution, the viscosity decreasing with decreasing concentration of the chromic salt. One part of chromic sulphate per hundred of water gave a soft but clear jelly; with fifty parts of water a firm jelly was obtained, and a very stiff jelly with thirty, twenty or nine parts of water. At higher concentrations the jelly is cloudy and less satisfactory. The concentration

<sup>1</sup> Cf. Fischer and Herz: *Zeit. anorg. Chem.*, 31, 357 (1902); *Olie*: 51, 29 (1906).

of one to twenty gave the best jelly and the jelly formed most rapidly. This concentration was, therefore, used in the subsequent experiments except when otherwise stated.

The next variable to be studied was the concentration of the sodium acetate. The figures refer to grams of sodium acetate per 20 cc solution. With 0.1 gram sodium acetate a green gelatinous precipitate was obtained. With 0.2 gram there was some tendency to form a jelly, especially if the alkali was added carefully. With 0.5 gram, 1 gram, and 2.5 grams sodium acetate, good jellies were obtained. With three grams sodium acetate, crystallization took place, which spoiled the jellies. With solutions containing over one gram sodium acetate no precipitate is formed on adding caustic potash and a good jelly is obtained in about twenty-four hours. The sodium acetate apparently peptonizes the gelatinous precipitate and prevents its separation. A jelly is formed when the hydrous chromic oxide comes out slowly.

The color of the jelly depends to a certain extent on the amount of alkali added. If the solution is made only just alkaline, a violet jelly is formed. With increasing alkalinity the color varies from a violet to a distinct olive-green. When ammonia is used, the jelly is always purple regardless of the amount of ammonia. It forms more slowly than when potassium hydroxide is added.

If enough hydrochloric acid is added to the jelly to make the mass distinctly acid to litmus, the jelly dissolves, the rate of solution being increased by heating. If the solution is made alkaline again with NaOH, KOH or  $\text{NH}_4\text{OH}$ , it jells on standing provided the amount of sodium acetate present is not too small. With low concentrations of sodium acetate a precipitate is formed on neutralizing the hydrochloric acid solution. This can be prevented by adding more sodium acetate to the acid solution before adding the alkali.

Some experiments were next made to determine the effect of various salts. Five solutions were made up containing one gram chromic chloride in 30 cc. water. To each was added 3 grams sodium acetate and then 2, 3, 4, 5, 6 cc, respectively,

of a solution of one part of NaCl in three of water. All solutions were heated to boiling, allowed to cool, and made alkaline with KOH (1 : 1). All five solutions jelled on standing.

Three solutions were made up containing 0.5 gram chromium sulphate and 2.5 grams sodium acetate per 20 cc water. To these were added 1, 3, and 10 cc KCl solution (1 : 3). On treating as before a firm green jelly was obtained in each case. Four solutions were next made up containing 0.5 gram chromium sulphate in 20 cc water. Potassium chloride and sodium acetate were added as follows:

- A. 0.2 gram KCl + 2 grams sodium acetate
- B. 2.0 grams KCl + 2 grams sodium acetate
- C. 1.2 grams KCl, no sodium acetate
- D. 1.2 grams NaCl, no sodium acetate

With A and B firm green jellies were obtained. With C and D gelatinous precipitates were formed. This shows that neither sodium chloride nor potassium chloride prevents the formation of a jelly provided sufficient sodium acetate be present, and also that neither of them can replace the sodium acetate. When these jellies are allowed to stand in an open beaker, the potassium chloride eventually crystallizes and destroys the jelly, a coagulated mass forming at the bottom of the beaker with a layer of greenish tinted water above it.

Sodium oxalate, potassium bitartrate, and citric acid were tried as substitutes for sodium acetate; but none of them made the solution set to a jelly even on long standing. For a long time the presence of acetate in the solution seemed to be essential to the formation of a jelly. Later work showed that potassium sulphate could apparently be made to work; and it is very probable that other salts may be effective when the proper conditions have been determined.

Our earlier experiments seemed to show that the time of heating must be regulated carefully. A solution containing 0.5 gram chromium sulphate and 2.5 grams sodium acetate per 20 cc water was acidified with hydrochloric acid, heated just to boiling, cooled, and neutralized with alkali. A jelly was formed. A similar solution was boiled for fifteen minutes



and then treated as before. No jelly was formed. This seemed fairly conclusive experimentally, but there was no apparent theoretical justification for it. The only conceivable reason for heating together sodium acetate and chromic sulphate is to accelerate the hydrolysis of the resultant chromic acetate into colloidal chromic hydroxide and acetic acid. If prolonged heating in itself destroys the tendency of the solution to jell when made neutral, it must mean that the hydrolysis must be stopped before equilibrium is reached, which did not seem probable. The other alternative was that prolonged heating was not detrimental except in so far as it volatilized the acetic acid. To test this point a solution was made up containing one gram chromic sulphate and one gram sodium acetate per 20 cc water. Three hundred cc of this solution was heated to boiling for eight hours, using a return condenser. The solution remained violet in color. When cooled and made alkaline, a stiff jelly was formed. In another experiment the amount of sodium acetate was cut down to 0.5 gram per 20 cc and the solution was boiled with a return condenser for eleven hours. On cooling and making alkaline a stiff jelly was obtained. We made a solution of one part chromic sulphate to twenty of water. To 20 cc portions were added amounts of sodium acetate varying from 0.1 to 3.0 grams. These were boiled in open beakers for varying lengths of time, keeping the volume practically constant by adding water from time to time. From the data thus obtained it was seen that solutions containing more than 1.5 grams sodium acetate could be heated for a long time and could still be made to give a good jelly. Solutions containing less than 0.5 gram sodium acetate gave a precipitate with alkali after being heated to boiling for several hours. All these results are what one would expect if the driving off of the acetic acid prevents the solutions from setting subsequently. The acetic acid would naturally pass off more quickly in the solutions acidified with hydrochloric acid.

Since the object of heating is apparently to hydrolyze the chromic salt, the same effect should be obtained cold if

one took time enough. A solution of one gram chromic sulphate and 1.5 grams sodium acetate per 20 cc was made up, neutralized with caustic potash and allowed to stand cold. In about two hours the solution turned violet and a firm jelly was formed after several hours more. A similar solution, to which alkali was not added, did not form a jelly on standing.

The effect of freezing was next tried, using ice and salt as the freezing mixture and leaving the solutions in it for five hours. A jelly which had stood in a open beaker for seven days was frozen solid. When thawed a jelly was obtained which appeared to be more granular than the original one. The experiment was repeated with a jelly which had stood for five days. The result was the same as before. A jelly, which had stood only two days was frozen and thawed to an amorphous mass which showed no tendency to form a jelly. When freshly formed jelly was frozen, layer ice formed on the surface. When thawed, this jelly gave an amorphous precipitate with supernatant liquid. When solutions were frozen before they had time to jell, they thawed to a liquid layer and an amorphous mass which showed no tendency to jell. After being frozen and thawed, the solutions do not form the film-like surface characteristic of the jellies. Any of the jellies which had been spoiled by freezing and thawing gave stiff jellies if the precipitates were dissolved in hydrochloric acid and the solutions then made alkaline. Freezing seems to disintegrate a jelly unless it is an old one and has had time to set and even then it has a noticeable effect. Freezing apparently breaks up the structure of the jelly and separates the water from the jelly. On standing the water does not recombine with the chromic oxide and consequently the solution does not jell.

Currant jelly can be disintegrated by picking at it with a fork. It, therefore, seemed desirable to test the effect of stirring. Solutions were divided into two portions, one being set aside as a check, while the other was stirred by means of a bent glass rod, the other end of which was inserted into the shaft of a small electric motor set vertically. After add-

ing KOH and before the solution had had time to set, the motor was started and the stirring continued for three hours. The solution did not jell or even coagulate. The solution that was not stirred, set to a jelly. In the next experiment the solution was stirred for one hour. It did not turn to a jelly even on long standing; but it began to thicken and a sediment collected in the bottom of the beaker. The check solution jelled. A third solution was stirred for twenty minutes. On standing, it coagulated and formed a sort of thick, viscous paste which was not a jelly. The unstirred portion formed a jelly.

We then tried stirring jellies which had just formed, stirring them anywhere from twenty minutes to three hours. On standing they all formed a thick, viscous paste of rather coarse structure. Freezing has a more marked effect in breaking up a jelly than does stirring.

Since acetate is important in producing a chromic oxide jelly it seemed to us that a chromic acetate solution should form a jelly on addition of potassium hydroxide. This proved to be the case. At this time we were not able to obtain a jelly by adding potassium hydroxide to a solution of chromic sulphate, chloride, or nitrate. From this we concluded that acetate was absolutely necessary to the formation of a jelly. This conclusion was upset very thoroughly when we found, just before the end of the college year, that a solution of chrome alum,  $\text{KCr}(\text{SO}_4)_2 \cdot 12\text{H}_2\text{O}$  will form a jelly on addition of potassium hydroxide. A precipitate is formed which dissolves in more KOH, yielding a clear green solution which turns to a jelly after standing for several hours. In Table I a concentration of 1 : 3 means one part chromic alum to three of water. The caustic potash solution (1 : 1) was added until the solution cleared. We did not make quantitative determinations of the amounts necessary, though that should be done some day.

The same experiments were repeated with ammonia, instead of KOH. The solutions as far as 1 : 50 gave a fine violet precipitate in the bottom of the beaker; the other concentrations gave clear violet solutions which showed no

TABLE I—CHROME ALUM AND POTASSIUM HYDROXIDE

Conc.	Character of deposit
1 : 3	Thick, gelatinous precipitate
1 : 6	Good jelly
1 : 9	Good jelly
1 : 12	Good jelly
1 : 18	Good jelly; little water on top
1 : 30	Good jelly; little water on top
1 : 50	Good jelly; more water on top
1 : 60	Good jelly; more water on top
1 : 100	Soft jelly at bottom; clear water on top
1 : 200	Soft jelly at bottom; clear water on top
1 : 300	Soft jelly at bottom; clear water on top
1 : 400	Soft jelly at bottom; clear water on top
1 : 800	Gelatinous precipitate at bottom; still slight tendency to form a jelly.

tendency to jell and which did not get viscous. Adding a larger excess of ammonia had no good effect nor adding KOH to the ammoniacal solution. We were not able to get a jelly with ammonia in the solution. We did not have time to determine whether an ammonia chrome alum would jell with ammonia. The solutions of chrome alum containing KOH gave the typical green color while solutions containing ammonia had the characteristic violet color.

We also tried adding sodium acetate to the chrome alum solutions. A jelly was obtained on adding KOH but it was apparently no firmer nor was it formed any more quickly than without the sodium acetate. Even with sodium acetate it was not possible to get a jelly by adding ammonia.

The time at our disposal did not permit us to test within what ratios of potassium sulphate to chromium sulphate it was possible to get a jelly on adding caustic potash, nor have we made any experiments to see whether these jellies behave as do the jellies made with acetate, when subjected to heating, freezing, acids, etc. We did try one experiment with a solution of one part chromic sulphate in ten of water. On adding KOH a precipitate formed at first; but this dissolved in an excess of caustic potash yielding a clear green solution. After

standing for several hours this solution began to get viscous; the next day it was very viscous. While the solution did not at any time set to a jelly, it showed a decided tendency to do so and we think that it may be possible to cause a chromic sulphate solution to form a jelly simply by adding caustic potash.

The jellies containing acetate shrink on drying, eventually cracking into squares, which finally dry to a powder. At no time is there any formation of a supernatant liquid layer. The reverse experiment was also tried of pouring water over the jellies carefully so as not to break up the surface of the jelly. After standing several days the water shows a green or violet tinge depending on the color of the jelly. The violet jellies, made with ammonia or with small amounts of caustic potash seem to be more soluble than the green jellies. When the jellies are heated with water, the water becomes colored quite deeply green or violet as the case may be, and there is a sediment in the bottom of the beaker which does not dissolve even when heated for several hours. Under the conditions that we have tried, the chromic oxide jellies are, therefore, not reversible in the sense that the gelatine jellies are.

We tried adding sodium acetate and then alkali to solutions of salts of manganese, aluminum, copper and cadmium. In no case were we able to get a jelly. The acetate method is therefore not a general one.

The general results of this paper are:

1. If a sufficient amount of sodium acetate be added to a solution of chromic sulphate or chloride, the subsequent addition of a suitable amount of NaOH, KOH or ammonia will cause the solution to jell.
2. The chromic oxide jelly is violet if made with ammonia or with a slight excess of potassium or sodium hydroxide. It is green if a considerable excess of potassium or sodium hydroxide be added.
3. The concentrations of the chromic salt and of the sodium acetate may vary within fairly wide limits without interfering with the formation of a good jelly.

4. It is not necessary to heat the solution after adding the acetate and before adding the alkali; but doing so increases the rate of hydrolysis and, therefore; cuts down the time necessary to form a jelly.

5. Prolonged heating of the solution has no effect on the subsequent formation of a jelly, unless acetic acid is driven off.

6. The chromic oxide jelly dissolves in hydrochloric acid and is formed again when the solution is neutralized, provided enough acetate be present.

7. When enough acetate is present, the concentration of sodium or potassium chloride seems to have no appreciable effect on the jelling of the solution, though it probably changes the limiting concentrations.

8. Sodium oxalate, potassium bitartrate, and citric acid could not be substituted successfully for sodium acetate.

9. Freezing solutions prevents the formation of jellies. If an old jelly be frozen, a coarser jelly is obtained after thawing; but if a freshly formed jelly be frozen, thawing yields a gelatinous precipitate and a supernatant liquid layer.

10. Stirring also prevents the formation of jellies.

11. The jellies made with acetate dry without any extrusion of a liquid layer.

12. When heated with water, the jellies break down to a gelatinous precipitate and supernatant liquid.

13. A jelly, once formed, does not swell in water to any appreciable extent.

14. The acetate method of obtaining jellies did not work with salts of manganese, aluminum, copper or cadmium.

15. A jelly can be formed by the addition of potassium hydroxide to a chromic acetate solution.

16. A jelly can be formed by adding potassium or sodium hydroxide to a chrome alum solution but not by adding ammonia.

17. Adding sodium acetate to a chrome alum solution seems to have no effect one way or the other. It does not make possible the formation of a jelly on adding ammonia.

18. No experiments have been made to determine how far it is possible to vary the ratio of potassium sulphate to chromic sulphate or to see whether these sulphate jellies behave in other respects like the acetate jellies.

19. No jellies were obtained by adding potassium hydroxide to solutions of chromic nitrate, chloride or sulphate. With chromic sulphate a very viscous solution was obtained on long standing and it seems possible that further study would show how to obtain a jelly with this salt.

20. In the absence of any satisfactory theory of jellies, negative results hold only for the particular experiments tried. It is not safe to generalize from them.

This investigation was suggested by Professor Bancroft and has been carried on under his supervision.

*Cornell University*

THE ATOMIC WEIGHT OF CADMIUM BY THE INVESTIGATION OF CADMIUM CHLORIDE AND CADMIUM BROMIDE\*

BY ELTON L. QUINN AND GEORGE A. HULETT

Among the large number of determinations of the atomic weight of cadmium made since the time of Stromeyer (1818)<sup>1</sup> we can find almost any value between 111.6 and 112.7.<sup>2</sup> A close concordance between the early determinations is hardly to be expected, but among those more recently made and where a better agreement would naturally be looked for practically none is found. The present accepted value of 112.4 is the mean of seven values all above 112.37 while an average of all the values as given by Clarke in his "Constants of Nature" gives us the value of 112.32.<sup>2</sup>

Our interest in the matter was awakened by the work of Perdue and Hulett,<sup>3</sup> wherein a method was devised which makes it possible to determine cadmium electrolytically in such a manner as to avoid inclusions. This was accomplished by means of the mercury cathode, the usual method of procedure being so modified that inclusions were precluded and very exact results obtained. Their analyses of very carefully purified cadmium sulphate crystals gave a percentage of cadmium measurably smaller than that calculated when the accepted atomic weight of cadmium is employed. The atomic weight indicated was 112.30.

In the work by Laird and Hulett,<sup>1</sup> on inclusions in electrolytic deposits, a cadmium coulometer was devised in which it was possible to deposit the cadmium in mercury, in much the same manner as in the Perdue-Hulett method. This, run in series with a silver coulometer, gave 112.31 as the atomic weight of cadmium.

\*The work described in this article was made possible by a grant from the Elizabeth Thompson Science Fund, which placed at our disposal some of the special apparatus and materials needed for this investigation, and the authors take pleasure in acknowledging their indebtedness to the Trustees of this Fund.



These two sets of results derived in such a different manner agreed so well that it seemed advisable to extend the investigation so as to include some determinations of cadmium in cadmium chloride and cadmium bromide. These salts have been much used in determining the atomic weight of cadmium; indeed, the accepted value depends largely upon the analyses of these compounds.

Since our results with these salts confirm those obtained by the methods mentioned above, it would seem that the real value for this constant is measurably below the accepted value of 112.4.

#### Preparation and Purification of Materials

*Cadmium.*—The sulphate is probably the most easily purified salt of cadmium and for this reason it was used as the starting point of our research. By the method of recrystallization it is possible to get cadmium sulphate in an exceptionally high state of purity, as it is not isomorphous with any known substance.<sup>1</sup>

Kahlbaum's best cadmium sulphate was dissolved in distilled water and the liquid diluted until a 10 percent solution was formed. By treating this solution with hydrogen sulphide so as to precipitate part of the cadmium as cadmium sulphide, digesting the whole on the water bath for twelve hours and filtering, we were able to obtain a solution practically free from other heavy metals present in the original salt. The filtrate was again treated with hydrogen sulphide and in a quantity sufficient to transform almost all of the cadmium into the sulphide. This was filtered off and, after very careful washing, dissolved in nitric acid which had been especially purified by distillation in a quartz distillation apparatus. After removing the free sulphur a calculated excess of sulphuric acid, purified by distillation in a vacuum, was added to the liquid, and the solution placed on the water bath where we permitted it to remain until all of the volatile acid had been expelled. The excess of sulphuric acid was next poured off, the  $\text{CdSO}_4$  heated to redness in a platinum evaporating dish

covered with a watch glass, transferred to a large flask, covered with distilled water and placed in a stirring apparatus so arranged that the flask could be rotated until a saturated solution was formed. On account of the slow rate of solution this operation sometimes required twelve hours. The solution was finally filtered into a large crystallizing dish and placed in our constant temperature balance room. By proper manipulation the maximum amount of clear crystals could be obtained, the crystals forming by the spontaneous evaporation of the solvent. Such crystals were removed from the mother liquor with ivory forceps and dried in a centrifuge. The process was repeated three times. The resulting cadmium sulphate crystals were large, "water clear," and beautifully formed. The cloudy crystals were dissolved and the crystallization process repeated.

Metallic cadmium was obtained from the pure cadmium sulphate by electrolysis. The apparatus in which the reduction was carried out consisted of a beaker with a filter paper anode cup supported at the top by means of a cork ring. A glass tube also passed through this ring to the bottom of the beaker. Into the end of this tube a platinum wire had been sealed so that only about one-half of a millimeter protruded to serve as a cathode. The anode was a piece of platinum foil about  $2 \times 3$  cm which was placed inside the anode cup. During the electrolysis the anolyte was allowed to get but slightly acid. This was accomplished by an occasional addition of cadmium carbonate which also served to keep the concentration of cadmium sulphate nearly constant. The cadmium formed under these conditions consisted of very fine crystals which sprouted from the cathode until the bottom of the beaker was completely covered. The current density was kept sufficiently low to permit of the formation of a very compact deposit of cadmium.

The cadmium carbonate used in the above electrolysis was prepared in the following manner: Conductivity water nearly saturated with pure ammonia was treated with pure carbon dioxide in excess and with this reagent cadmium in

the form of  $\text{CdCO}_3$  was precipitated from a solution of our purified cadmium sulphate. The cadmium carbonate was filtered off, washed, dried and kept in glass-stoppered bottles until used.

After a sufficient amount of cadmium had been obtained, it was removed from the beaker, separated from the electrolyte and washed many times with distilled water. Whether the metal is deposited in a platinum dish or as above described, it is impossible to remove all of the electrolyte by simply washing, as part of it is sure to be included in the crystals. To remove all of the inclusions and get the metal into a hard compact form, we melted the crystals under pure resublimed ammonium chloride. The ammonium chloride acts as a reducing agent and would tend to reduce any oxide or sulphate which might have been dissolved in the metallic cadmium. The ingot thus obtained was clean and bright and could be easily separated from the ammonium chloride which formed a crust on the surface. It was then washed and placed in a hard glass tube so arranged that after the highest possible vacuum had been made over the molten cadmium, it could be distilled from one compartment into another. When most of the cadmium had passed over, the molten distillate was run into a drawn-out end of the tube which was sealed up until used. The cadmium with which our determinations were made was distilled twice by this same process.

*Cadmium Chloride.*—Part of our pure distilled cadmium was cut into small pieces with a clean pair of steel shears, placed under conductivity water in a Jena glass flask and pure hydrogen chloride gas run in from a generator which will be described later (Fig. 1). After all the cadmium had dissolved, the solution was transferred to a platinum evaporating dish, covered with a watch glass and evaporated to dryness on a water bath. The salt was dried as far as possible on the water bath, and then put into an oven and heated to about  $200^\circ \text{C}$  for several hours. It was finally broken up, removed with a platinum spatula and preserved in a glass-stoppered bottle.

*Method of Analysis.*—The general method of melting cadmium chloride under pure dry hydrogen chloride was the same as that used by Baxter and Hines<sup>3</sup> in their work on the atomic weight of cadmium in 1905. The hydrogen chloride was generated and used in the following apparatus: in the large two-liter flask (a) (Fig. 1) was placed the purest grade of Baker's hydrochloric acid. The hydrogen chloride was driven from this by heating the flask gently. The gas was dried by first passing it through the condenser placed in the Dewar tube (c) and surrounded by the freezing mixture (b). The freezing mixture was made by mixing finely ground ice

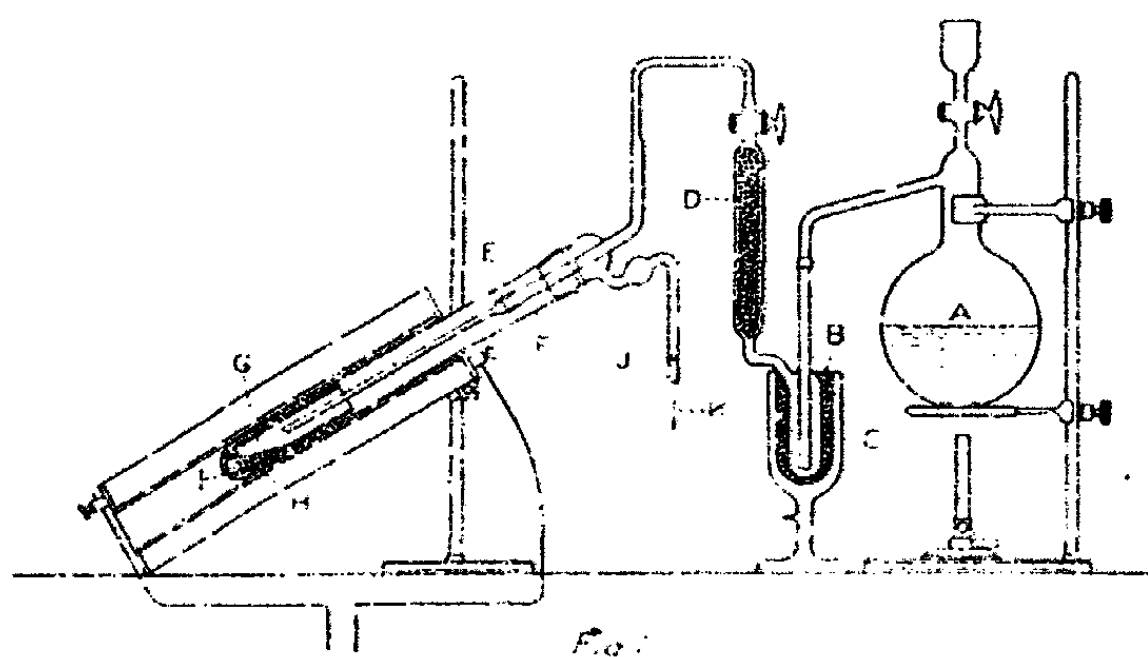

and ground crystallized calcium chloride. The temperature was kept at about  $-20^{\circ}\text{C}$  by this mixture and practically all of the water was removed. The gas then passed through the calcium chloride tube (d) and from there into the fusion apparatus (f). This consisted of a large, hard, glass tube provided with a very carefully ground glass stopper. The stopper was similar to that of a Drexel wash bottle and the tube passing through was ground on to a small quartz tube shown at (e) which conducted the hydrogen chloride over the cadmium chloride in the quartz crucible (g). The excess of gas then passed out through the tube (k) which was connected with a suction pump. The small opening (i) allowed air to enter,

so the pressure in the apparatus was not reduced. To prevent the tube from breaking on cooling from a high to a low temperature a wad of asbestos was placed at (*i*). The tube was heated in a platinum resistance furnace with a 110 volt alternating current. By means of an adjustable resistance the temperature could be regulated very well. The connection between the fusion tube and the generator was always sealed before a fusion was made so that all joints were of glass or ground together.

*Crucible.*—Our first idea was to use a platinum Smith crucible, but we soon found that platinum would not do, as the molten cadmium chloride at that high temperature dissolves quite an appreciable amount of this metal. Baxter and Hines<sup>6</sup> in their work made corrections for the dissolved platinum. However, the large amount lost by our crucible at each heating made it necessary for us to look for some other material. Table I gives the loss in weight of the crucible during four heatings.

TABLE I

	Weight before heating Grams	Weight after Grams	Loss in weight Gram
1	24.82894	24.82888	0.00006
2	24.82888	24.82592	0.00296
3	24.82592	24.82431	0.00161
4	24.82349	24.82349	0.00082

From these figures we see that the total loss during four fusions was somewhat over 5 mg. It seemed that platinum would be useless for this work, so we tried quartz. At first the special quartz crucible we used lost weight, and sometimes the loss was quite appreciable. The loss, however, did not take place when we washed the crucible carefully and took special care that our hands did not afterwards come in contact with its surface. Our crucible was a closed quartz tube about 8 cm long, with a platinum cap very accurately ground on the top. A cross-section of the tube is shown at (*g*) (Fig. 1).

The next step was to find an exact and delicate test for

cadmium in an acid solution such as would result upon the evaporation of our electrolyte after electrolysis. Potassium ferrocyanide was first tried and, in a neutral solution, it worked very well. Cadmium may be detected by this means when the concentration is as small as 0.008 mg per cc. However, when this test was applied to our evaporated electrolyte it was found to be useless. The solution usually turned dark blue and sometimes gave a precipitate even when there was no cadmium present. This was proved by running several blank tests. It is possible that persulphuric acid ( $H_2S_2O_8$ ) was formed in the electrolyte, and this produced Prussian blue by its action on the ferrocyanide. We next made determinations by treating small concentrations of cadmium sulphate with hydrogen sulphide gas. The tests were carried out in tubes of the Nessler form but holding, when filled, only about 2 cc of solution. Blanks were run at the same time in similar tubes and under like conditions. We tried the following concentrations:

0.0843 mg Cd to 1 cc water  
0.042 mg Cd to 1 cc water  
0.021 mg Cd to 1 cc water  
0.0084 mg Cd to 1 cc water

The cadmium in the first three could be detected at once, while the liquid in the fourth was slightly colored after standing a day. Since the blank used for comparison in the latter case was treated in the same manner, and allowed to stand the same length of time, the difference in color must have been due to cadmium sulphide and not to free sulphur. We evaporated all of our electrolytes to 1 cc, and tested each in this manner so there was little chance for any cadmium to escape deposition without being detected.

All of our weighings were made in an especially designed balance room. The Borda method of substitution was used, and the readings of the pointer taken by means of telescope. The temperature of the room was always under control, being kept practically constant. The moisture content of the room was also under control. The air which entered the room was

forced through a large, upright cylinder of calcium chloride by means of an electric fan. In all our weighings the pressure, temperature and humidity were recorded, so at any time we could calculate the weight of 1 cc of air. The average weight was 1.17 mg per cc and the variations from this were so slight as to be negligible. The object was always allowed to stand inside the balance room at least one hour before a weighing was attempted, and after placing the object on the balance pan we always waited at least ten minutes for the temperature to become constant before the readings were taken. All of our weights were very carefully calibrated.

The vacuum correction was calculated from the density of cadmium chloride, found by Baxter and Hines<sup>5</sup> to be 4.049. We found the correction to be +0.153 mg for each gram of cadmium chloride weighed. The correction for the cadmium dissolved in mercury was taken from the work of Perdue and Hulett who found it to be -0.014 mg for each gram of cadmium dissolved in mercury.<sup>6</sup>

The problem of electrolyzing a chloride solution in a crucible such as we proposed to use was a very difficult one to solve. The chlorine liberated at the anode acted on the mercury in such a manner that the electrolyte as well as the mercury was blackened. To prevent this we tried electrolysis in a vacuum, also inclosing our anode in a glass cup. As none of these methods were successful we undertook to change the chloride to the sulphate before electrolysis. This plan worked very satisfactorily. A solution of the cadmium chloride in water was transferred to a platinum evaporating dish which was covered with two watch glasses. One was small enough to be placed in the dish with the concave surface down. A small hole was drilled through its center for the escape of vapors. The other was larger and placed over the evaporating dish with the concave surface up. Two holes were drilled through this glass, one on each side of the center. With these watch glasses over the solution it was impossible for any to escape by spattering. However, a free passage for the water vapor was provided for and the evaporation proceeded at a fair

rate. To the cadmium chloride was added a slight excess of the calculated amount of sulphuric acid and the whole evaporated to dryness on the water bath. It was then transferred to a hot air oven and heated slowly to  $220^{\circ}\text{C}$ . After the sulphuric acid had fumed for some time it was cooled and transferred to the crucible for electrolysis.

The electrolysis apparatus consisted of a specially designed platinum crucible of about 100 cc capacity. The diagram in Fig. 2 shows the arrangement of this crucible with the rest

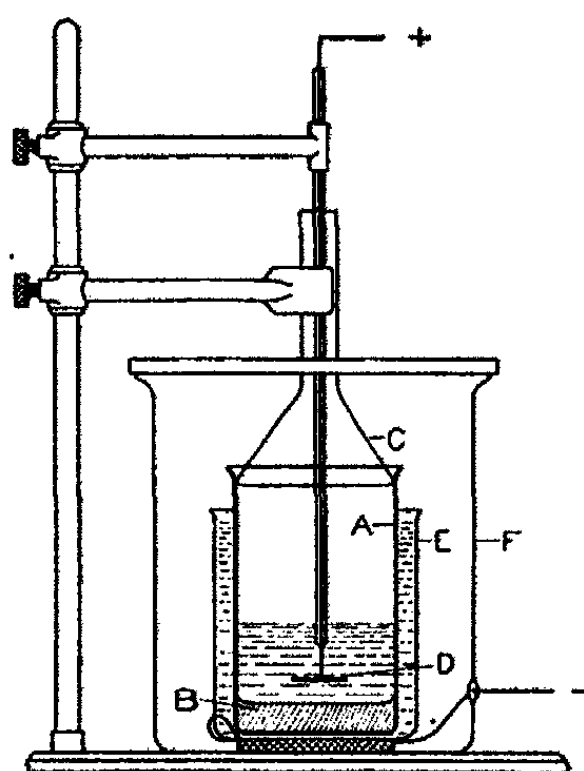

-Fig. 2-

of the apparatus. Fitting in the crucible (*a*) is the carefully ground glass funnel (*c*), which served as a cover and allowed the anode (*d*) to pass through the stem. The crucible was amalgamated with mercury by heating a small amount in the bottom to its boiling point and allowing the vapor to condense on the sides up to about 1 cm from the top, so that by rotating the crucible on its side a continuous film of mercury would wet its sides and bottom. It was then placed in the small glass cup (*e*) and surrounded with distilled water, the cup resting in a larger glass jar (*f*), and the space between being filled with ice water. A split glass plate covered the top of



the jar so that nothing but the funnel stem protruded. The electrical connections were made by means of a platinum wire through the glass jars to the crucible inside. All the mercury used in these determinations was distilled three times, and was exceptionally pure. After the crucible had been amalgamated, and before it was weighed, it was washed on the outside, first with dilute nitric acid and then with distilled water. Afterwards it was placed in a desiccator and allowed to dry.

The actual operation carried out during each determination was as follows: A definite amount of cadmium chloride was placed in the quartz crucible (after it had been weighed) and the charged crucible introduced into the fusion apparatus. After this apparatus had been sealed to the hydrogen chloride generator it was heated in the furnace to about  $600^{\circ}\text{C}$  and at the same time a slow stream of dry hydrogen chloride was passed over the salt. When melted and still in the molten state, the inlet tube was sealed off above the apparatus, and the outlet tube sealed off below. The tube was then taken from the furnace and laid upon its side on an asbestos mat. This allowed the molten cadmium chloride to cool on the side of the crucible so that the solid mass was easily removed when desired. After it had cooled to the room temperature the tube was cut open under a stream of pure, dry air which at once filled the partial vacuum formed. With a stream of pure, dry air flowing over the top of the tube the stopper was removed and the platinum cap quickly placed on the crucible by means of a glass rod. The crucible containing cadmium chloride, hydrogen chloride and dry air was then removed and as quickly as possible wiped and placed in a vacuum desiccator which was evacuated to a pressure of about 0.1 mm. After the desiccator had remained in the balance room for several hours, air was allowed to enter through a calcium chloride tube and the weighing was made. The calcium chloride was then removed from the crucible and placed in a covered platinum dish. The crucible was well washed with water and set aside to be tested later for cadmium. To the cadmium chloride solution a slight excess of pure sulphuric acid was

added, the liquid evaporated and then heated to fuming. The cadmium sulphate formed in this way consisted of small, anhydrous crystals which were easily removed with a platinum spatula and placed in the tared crucible for electrolysis. The watch glasses as well as the quartz crucible were washed with a small amount of water and the washings added to the crucible. Finally they were washed with a large amount of water and this was evaporated to about 1 cc and the solution tested for cadmium. None was ever found, however, and during the last of our determinations the evaporated wash water was added to the electrolyte in the crucible.

The solution was then electrolyzed for about seven hours, starting the current at about 200 milliamperes and then bringing it up to about 500 which current strength was maintained during the greater part of the run. Before the electrolyte was removed the current was run up to about one ampere for one-half hour. All this time the temperature of the crucible was never allowed to rise above room temperature. After the run was completed the electrolyte was drawn out by means of a pipette while water was simultaneously run in. This was accomplished in such a way that the current was never interrupted or the mercury agitated. After the ammeter showed no current to be passing, the rest of the water was removed and the crucible transferred to a vacuum desiccator which was evacuated with an air pump. In a very short time the crucible was ready to weigh.

The results we obtained are shown in Table II.

The probable error for a single determination is  $\pm 0.004$  percent, while the probable error for the mean is  $\pm 0.001$  percent.

The question of any error in the method or losses due to changing the chloride to sulphate was regarded as most important, and direct information was obtained on these points by the following experiments and blank determinations:

The pure metallic cadmium was cut into small pieces and a definite amount weighed out. This was placed in a platinum evaporating dish and covered in the same manner

TABLE II—ATOMIC-WEIGHT DETERMINATIONS ON  $CdCl_2$ 

Number of determination	Weight of $CdCl_2$ Grams	Vacuum correction Gram	Mass of $CdCl_2$ Grams	Weight of Cd Grams	Vacuum correction Gram	Mass of Cd Grams	Percent of Cd	Atomic weight of Cd
1	4.10058	+0.00061	4.10119	2.51430	-0.00003	2.51427	61.306	112.36
2	4.47084	+0.00067	4.47151	2.74087	-0.00003	2.74084	61.295	112.31
3	5.66376	+0.00076	5.66452	3.47184	-0.00004	3.47180	61.290	112.28
*4	5.99200	+0.00091	5.99291	3.67216	-0.00005	3.67211	61.274	112.20
5	6.52811	+0.00099	6.52910	4.00224	-0.00005	4.00219	61.298	112.32
6	4.87342	+0.00073	4.87415	2.98789	-0.00004	2.98785	61.300	112.33
7	4.88350	+0.00073	4.88423	2.99388	-0.00004	2.99384	61.296	112.31
Average							61.297	112.32
Atomic weight of Cl taken as 35.458							±0.001	±0.01

\* Determination No. 4 was excluded in the final average as the cadmium deposited in flaky crystals on the side of the crucible and it is probable that some was lost during the washing.

as our cadmium chloride. It was then treated with distilled hydrochloric acid, evaporated to dryness, and, after dilution, the necessary amount of sulphuric acid was added. After evaporating and heating the liquid in a manner similar to that employed in the case of our cadmium chloride, the sulphate was dissolved, the solution electrolyzed and the deposit weighed. As all of the operations were carried out as nearly as possible as they were with our chloride the error of all the manipulations would be ascertained. Our blank experiments are shown in Table III.

TABLE III

No.	Weight before Grams Cd	Gain in weight of the crucible Grams Cd	Difference Gram
1	2.23578	2.23552	-0.00026
2	2.11198	2.11225	+0.00027
3	2.79347	2.79331	-0.00016
4	2.02396	2.02379	-0.00017
5	1.55217	1.55232	+0.00015

It appears from these experiments that we can start with a weighed piece of our pure cadmium, change it to the chloride, then to the sulphate, deposit it in mercury and get the weight of the original cadmium and all of the errors combined are not greater than one part in 10000 for the probable error of a single determination.

#### Cadmium Bromide

Our next investigation was on the bromide of cadmium. This is a beautiful, white salt which, since it can be easily purified, is exceptionally well suited for atomic-weight determinations. The method for the determination of the cadmium in this salt was very similar to the one used in the case of the chloride; modifications were made only when the nature of the salt made this necessary.

#### Purification of Materials

*Cadmium.*—The cadmium employed in all of these determinations was a sample of that used by us for the preparation of the chloride.

*Bromine.*—The best grade of Kahlbaum's bromine was purified in much the same manner as that described by Weber<sup>7</sup> in his work on the atomic weight of bromine. It was distilled three times from solution of potassium bromide. The potassium bromide was made by treating pure potassium oxalate with bromine and crystallizing the potassium bromide thus formed. After the distillation the bromine was cooled until most of it had crystallized. The mother liquor was rejected. The crystals were then allowed to melt somewhat and the liquid bromine poured off. The remaining crystals were melted again and the process repeated until bromine with a melting point of  $-7.2^{\circ}$  C was obtained. By this treatment Weber was able to purify the bromine so that the presence of chlorine or iodine could not be detected by any known reagents. This pure bromine was used in the preparation of our cadmium bromide, as well as for the preparation of the hydrogen bromide under which the cadmium bromide was melted.

*Hydrogen.*—The hydrogen was prepared by the electrolysis of a solution of pure potassium hydroxide from which the carbonates had been precipitated with barium hydroxide. After the generator had been started it was allowed to run for several days before we connected it with our hydrogen bromide apparatus.

*Preparation of Cadmium Bromide.*—For the preparation of this salt a portion of our purest metallic cadmium was cut into small pieces with a clean chisel. This was placed in a quartz evaporating dish and treated with our purified bromine under conductivity water slightly acidified with hydrobromic acid. Our first lot was treated under ordinary distilled water and the resulting cadmium bromide gave tests for organic matter. This lot was discarded and the next lot was dissolved in our best conductivity water which showed no trace of organic matter whatever. The bromine was added to the cadmium in small portions until most of the metal had gone into solution. The solution was filtered through especially purified asbestos and evaporated almost to the saturation

point of the solution. The quartz dish with its contents was then placed in our constant temperature room and the salt allowed to crystallize by spontaneous evaporation of the liquid. It was possible to get very clear crystals, which we removed and dried in a platinum dish in a vacuum desiccator. The salt was preserved in glass-stoppered bottles until used.

This salt like the chloride was fused in an atmosphere of the corresponding acid before the determination was made. Here we used a mixture of nitrogen and hydrobromic acid gas, instead of the pure acid gas as we did in the case of the chloride. Fig. 3 gives an idea of the apparatus we used for this purpose.

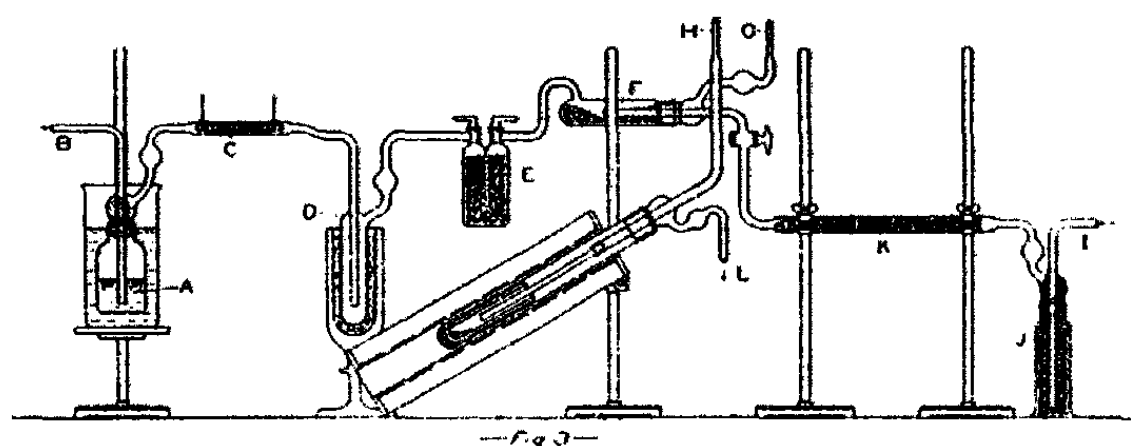

Pure hydrogen from our electrolytic generator was bubbled through the pure bromine (*a*) in the Drexel wash bottle. This was arranged as shown in the figure with a water bath around it so that a temperature of  $60^{\circ}\text{C}$  could be maintained. The mixture of hydrogen and bromine vapor passed over the glowing platinum spiral (*c*), made by winding a platinum wire on a small porcelain tube. The ends were gold-soldered to heavy platinum leads, and these were sealed through the sides of the glass tube. Combination of the hydrogen and bromine took place at the point (*c*) and burned with a bright flame. The excess of bromine (we always kept an excess of bromine in the mixture) was condensed in (*d*) which was surrounded with ice. Only a trace of bromine remained in the gas after passing it through this cooling mixture. The gas was then dried by passing through the bottle (*e*) which contained pure calcium bromide. It was finally dried by passing through

the drying tube (*f*) which contained phosphorus pentoxide and which served as a mixing chamber for the nitrogen and hydrogen bromide. This gas mixture was conducted over the cadmium bromide by means of a glass tube sealed to the fusion apparatus at the point (*h*). The fusion apparatus is shown more in detail in Fig. I. The nitrogen which entered the apparatus at (*i*) was made by removing the oxygen from the air by a method devised by Hulett.<sup>8</sup> It was stored in a large carboy and forced out under pressure by displacement with water. The preliminary drying was effected in the cadmium chloride tube (*j*). After passing over heated copper and copper oxide the gas was further dried with soda lime, and finally in the mixing chamber, by phosphorus pentoxide. All connections were sealed and the stopcocks in cases where it was absolutely necessary contained but a very small amount of "Vacuum Hahnfett." The fusion tube containing the cadmium bromide was always sealed to the apparatus at (*h*), and, after the cadmium had melted, it was sealed off and the outlet to the tube also sealed.

Treated in the same manner as the cadmium chloride, the tube was removed from the furnace and after cooling cut open and pure, dry air allowed to enter the partial vacuum produced by the cooling. The quartz crucible was then quickly covered with a platinum cap and after wiping placed in a vacuum desiccator which was evacuated at once. After standing in the balance room for some time dry air was let into the desiccator and the tube weighed. This operation was carried out in exactly the same manner as described under the chloride determinations.

To change the bromide to the sulphate we transferred it to the platinum evaporating dish, covered it with a watch glass and treated it with a few drops of pure, distilled nitric acid. The bromine thus liberated was driven off with gentle heat and the operation repeated until all of the bromide had been changed to the nitrate. This solution was then evaporated on the water bath to dryness. A small amount of water was then added and the calculated amount of sulphuric acid

also added after the salt had gone into solution. This was evaporated to dryness and electrolyzed in the usual manner. All of the precautions against loss which we used with the chloride were also used with this salt. As there might be some question about platinum being dissolved from the evaporating dish by the free bromine, the last three of our determinations were made in a Jena glass flask, provided with a ground glass stopper arranged with an outlet tube containing a series of bulbs to prevent loss by spattering. This was heated over a free flame and after all of the bromine had been driven off, the solution was transferred to the evaporating dish and treated with sulphuric acid as before. The results seem to indicate that no appreciable amount of platinum could have been dissolved in the first case.

Blank tests were made in a manner similar to that described under cadmium chloride. All of these results are shown in Table III.

The results for the cadmium bromide determinations are shown in Table IV.

The probable error for a single determination is  $\pm 0.003$  percent, while the probable error for the mean is  $\pm 0.001$  percent.

From our chloride results we get as an average 112.32 for the atomic weight of cadmium and from the bromide an average of 112.26. The average of these two is 112.29, which is in excellent agreement with the results of Perdue and Hulett, and those obtained by Laird and Hulett. These results go to prove that the atomic weight of cadmium is nearer 112.3 than the present accepted value 112.4.

We attempted to get more evidence on the atomic weight of cadmium by making determinations on cadmium oxide but it seemed to be a difficult operation to prepare this substance in a high state of purity. Our idea of burning pure cadmium vapor in carefully purified oxygen worked out very satisfactorily, and we constructed an apparatus with which we were able to prepare large quantities of the oxide in a very short time, but the resulting oxide was found to contain a trace of



TABLE IV—ATOMIC-WEIGHT DETERMINATIONS ON CdBr<sub>2</sub>

Number of determination	Weight of CdBr <sub>2</sub> Grams	Vacuum correction Gram	Mass of CdBr <sub>2</sub> Grams	Weight of Cd Grams	Vacuum correction Gram	Mass of Cd Grams	Percent of Cd	Atomic weight of Cd
1	4.95493	+0.00045	4.95538	2.04471	-0.00003	2.04468	41.261	112.28
2	4.15765	+0.00036	4.15801	1.71575	-0.00002	1.71573	41.263	112.29
3	5.31224	+0.00048	5.31272	2.19186	-0.00003	2.19183	41.256	112.26
4	4.55504	+0.00040	4.55544	1.87943	-0.00003	1.87940	41.256	112.26
5	4.31487	+0.00038	4.31525	1.78015	-0.00002	1.78013	41.252	112.24
6	5.69595	+0.00051	5.69646	2.34986	-0.00003	2.34983	41.251	112.23
7	4.47708	+0.00040	4.47748	1.84757	-0.00003	1.84754	41.263	112.29
8	5.36228	+0.00048	5.36276	2.21231	-0.00003	2.21228	41.253	112.24
Average							41.257	112.26
Atomic weight of Br taken as 79.92							±0.001	±0.005

the peroxide. This was also noticed by Sidot,<sup>9</sup> who made cadmium oxide by burning cadmium in the air. As this impurity was not easily removed we found it necessary to devise some other method for preparing the compound.

*Laboratory of Physical Chemistry,  
Princeton University,  
April, 1913*

## REFERENCES

- <sup>1</sup> Berzelius' Lehrbuch, 5th Aufl., 3, 1219.
- <sup>2</sup> Clarke: "The Atomic Weights," Smithsonian Miscellaneous Collections, 54, 3, 235.
- <sup>3</sup> Jour. Phys. Chem., 15, 147 (1911).
- <sup>4</sup> Trans. Am. Electrochem. Soc., 22, 385 (1912).
- <sup>5</sup> Jour. Am. Chem. Soc., 27, 222 (1905).
- <sup>6</sup> Jour. Phys. Chem., 15, 163 (1911).
- <sup>7</sup> Jour. Am. Chem. Soc., 34, 1296 (1912).
- <sup>8</sup> Ibid., 27, 1415 (1905).
- <sup>9</sup> Comptes rendus, 69, 202 (1869).

## NEW BOOKS

**A Dictionary of Applied Chemistry.** By Sir Edward Thorpe. Vol. IV. 23 × 17 cm; pp. vii + 727. New York: Longmans, Green & Co., 1913. Price: \$13.50 net.—This volume begins with oilstones and ends with sodalite. Among the interesting items are: oleo-resins; opium; osmium; oxalic acid; oxydases; oxygen; ozone; paints; palladium; paper; paraffin; parchment; perfumes; petroleum; phenol and its homologues; phosphorus; photography; pigments; pitch; plant-sprays; platinum; polarimetry; potassium; pottery and porcelain; primuline and its derivatives; proteins; ptomaines; pyrometry; pyrotechny; quartz; quercitron bark; quinoline; quinones; racemism; radio activity; radium; refractometer; resins; resinate lakes; rubber; rum; rust; salicylic acid; sandstone; saponification; sewage; silicon; silk; silver; smoke and smoke prevention; soap.

The articles on paints and on pigments overlap more than is desirable and could better have been condensed into one. Under silicon, Tone's process has been overlooked and there is practically nothing on the commercial uses of silicon. The article in photography is not what it should be and photochemistry is omitted entirely. Barring these slips there is little to be said in the way of criticism, though there might well have been an article on plastics in general. The account of the origin of the Stassfurt deposits is of exceptional interest, p. 340.

"If we compare the composition of the Stassfurt deposits with the results of the artificial evaporation of sea-water as carried out in 1849 by Usiglio, we find that there are some differences, partly caused by the long duration of the natural process and its yearly interruption, partly by the loss of mother liquor. The various salts were transformed into the minerals now present by a subsequent loss of water and by their mutual inter-action, and a regular succession of those minerals was formed through long periods, caused by the autumnal influx of fresh sea-water. One remarkable difference also is this: whilst in artificial evaporation the calcium sulphate is entirely precipitated at an early stage, it is formed at Stassfurt even in the strata consisting of mother-liquor salts. Why the calcium sulphate at Stassfurt is in the form of anhydrite, not in that of gypsum ( $\text{CaSO}_4 \cdot 2\text{H}_2\text{O}$ ), as in the artificial evaporation of sea-water, we understand now from the observations of Hoppe-Seyler and Rose, according to which the hydration water of gypsum is abstracted from it by contact with a *nearly-saturated* solution of sodium chloride, a condition which we must assume to have existed at Stassfurt.

"It is quite evident that the Stassfurt deposits have not been formed by the simple evaporation of a basin of normal sea-water, which would have been required to possess a depth of about 30 miles, and which would have produced a very different arrangement of salts. There must have been conditions similar to those even now found present in some of the Sarmatian lakes. Thus Göbel found at the bottom of Lake Elton a salt deposit of a thickness of 12 feet, consisting of 100 annual layers, which increased in strength and hardness from the top downwards, and at the bottom were as hard as stone. This lake is filled with a saturated brine; by the surface-evaporation in summer, crusts of common

salt are formed, which sink to the bottom. Later on, the common salt gets mixed with Epsom salt and other mother-liquor salts, which forms a porous, bitter, and deliquescent layer. The autumnal rains and floods partly dissolve and partly densify this top layer, and at the same time cover it with black mud, thus forming a distinct boundary line upon which the next year's crusts are formed again. In spring the water of that lake contains 13.5 p. c. sodium chloride and 10.5 p. c. of magnesium chloride; in autumn it holds but a small quantity of liquor containing only 4 p. c. NaCl, with 20 p. c. MgCl<sub>2</sub>.

"The nearest approach to the Stassfurt conditions is found in the Adji-Darja Bay, in the east of the Caspian Sea, a bay of a superficial area of 2000 or 3000 sea miles, and almost entirely separated from the Caspian by a bar. There is, however, a small channel through which the water, abstracted by the intense evaporation within the bay, is replenished from the Caspian. This causes a continuous separation of salt, which is estimated by Schleiden at about 400,000 tons per diem, and the formation of a mother-liquor, part of which finds its way back into the Caspian. Where the depth of the bay is greater, the concentrated liquor sinks to the bottom, causing a state of sursaturation at this place and the deposition of mother-liquor salts. Without this, practically all the mother-liquor would flow back over the bar, and no mother-liquor salts would be formed; and this seems to have been the condition of most of the rock-salt, forming basins of former geological periods. In the case of the Stassfurt salts we must undoubtedly assume an *intermittent* influx of water, and also a number of geological elevations and depressions of level in order to account for the succession of the various strata. We may, with very great probability, assume the following play of causes: the Stassfurt basin was a valley, inclosed by two longitudinal folds of the earth's crust, communicating at one end with the ocean by a shallow bar, over which, in autumn, the gales and high tides carried large quantities of sea-water; not sufficient, however, to replace the water lost by evaporation. For a long period only gypsum was deposited here; afterwards common salt was formed as well, which converted the gypsum into anhydrite, but which for a long time was re-dissolved every autumn by the dilution of the liquor, caused by rain and floods. Thus the thick crust of gypsum and anhydrite was formed which lines the bottom of the basin. Later on, the liquor became more and more concentrated; the crusts of common salt now became permanent, and the yearly deposits increased in thickness. The sursaturation of the liquor at the bottom caused the transformation of the common salt into rock-salt (as first proved by Mohr). Just as we observe it now in the 'salt gardens' on the Mediterranean, the last portions of the summer salt contained a little gypsum, but the greatest quantity of gypsum was precipitated when the strong brine came into contact with fresh sea-water breaking over the bar, thus forming a distinct line of separation against the next year's deposits in the shape of the 'anhydrite strings.' Since there was less and less room in the basin for fresh sea-water, those strings decreased in thickness during this period, which must have lasted several thousands of years, during the later part of which the yearly deposits had an average thickness of 3.5 inches. Owing to further concentration of the liquor the crusts of salt in the later part of summer were more and more mixed with Epsom salt, which appears also with the gypsum precipitated soon after by the influx of fresh sea-water. In this period, which must have lasted 500 or 600 years, *poly-*

*halite*,  $K_2SO_4 \cdot MgSO_4 \cdot 2CaSO_4 \cdot 2H_2O$ , was formed in the following way: some carnallite,  $KCl \cdot MgCl_2 \cdot 6H_2O$ , formed in summer, was at that period always decomposed in autumn by fresh sea-water, and the potassium chloride thus set free and coming into contact with the deposited Epsom salt was converted into potassium sulphate, which met with enough magnesium and calcium sulphate to form polyhalite. Exceptionally, indeed, carnallite is actually found in that region. During the next period of 500 years, with increasing concentration, some carnallite was regularly formed, but the principal deposit at that time consisted of *kieserite*,  $MgSO_4 \cdot H_2O$ . It has been proved by Precht that from a concentrated solution of magnesium chloride, such as must have filled the basin at that period, the magnesium sulphate is separated by evaporation, not in the state of Epsom salts ( $MgSO_4 \cdot 7H_2O$ ), but in that of *kieserite*. This compound being insoluble, as well as the anhydrite, the formation of polyhalite was not possible any more.

"During the fourth and last period of 500 years, when there was less room for the influx of fresh sea-water, the formation of *carnallite* got the upper hand. Pfeiffer has proved that that salt, and even hydrated magnesium chloride can be made to crystallize by spontaneous evaporation at the temperature of hot summer days in our present climate. The formation of carnallite must have been still abundant, and a deep layer of mother-liquor, in which magnesium chloride prevailed, must have been standing over the potash-bearing strata when new geological changes caused the eruption of a mighty mass of clayey mud, charged with organic substances, which sank to the ground, forming a layer of salt clay, 26 feet thick, which protected the underlying strata against a subsequent solution of the salts previously deposited, even after the mother-liquor had run off. The loss of that liquor accounts for the difference between the average composition of the Stassfurt deposits and that of the sea-water. Wherever such accidental protection was not afforded, the surface-water must have redissolved the upper strata, which accounts for the general absence of mother-liquor salts in other localities."

As a sample of condensed information, the reviewer calls attention to the paragraph, p. 101: "The art of making parchment consists in certain manipulations necessary to prepare the skins of animals of such thinness, flexibility and firmness as may be required for the different uses to which this substance is applied. Though the skins of all animals may be converted into writing materials only those of the sheep or the she-goat are used for parchment; those of calves, kids, and still-born lambs for vellum; those of the he-goat, she-goat, and wolves for drum-heads; and those of the ass for battledores."

*Wilder D. Bancroft*

*Ausführung qualitativer Analyse.* By *Wilhelm Biltz*. 17 × 25 cm; pp. iv + 128. Leipzig: Akademische Verlagsgesellschaft.—In the introduction the author says:

"There have been curious developments in the art of analysis. People used to recognize the remarkable educational value of analysis to the youthful chemist. Later, people believed it wise to include in courses of analytical chemistry many other things which also had an educational value. Consequently excellent books were written which were however better suited to introduce the student to chemistry than to teach him analysis. In this book an attempt will

be made to free the art of analysis from all the things which people have superposed for pedagogic reasons, and to keep solely in mind the true aim of analysis, to determine the composition of a material in the surest, quickest and most accurate way."

The three divisions of the subject are: analysis by the dry way; analysis by the wet way; testing for acids. The author lays special stress on blow-pipe tests because other authors have considered "qualitative analysis to mean working with aqueous solutions, because the theory of electrolytic dissociation is directly applicable to these, while analysis by the dry way has been rather forgotten owing to a lack of an interesting theory."

Towards the end of the book, p. 126, the author says that it is repugnant to one's sense of fitness:

1. To use a gram of substance and to spend two days when one could have obtained the same results with one-tenth the substance and one-quarter the time.
2. To use hydrogen sulphide gas involving an incomplete, tedious, and troublesome operation when one can get the same results more completely, more comfortably, and more quickly by using hydrogen sulphide solution.
3. To set up a distilling flask and a reflux condenser when one can do better with a few test-tubes.
4. To take the trouble to separate iron and manganese by carrying out superficially the quantitative sodium acetate method when it is sufficient to show the presence of the two by two color reactions.
5. To complicate the course of analysis hopelessly by introducing methods for rare elements instead of identifying them by means of the blow-pipe and removing them.
6. To work with a platinum crucible and a blast lamp when one can do as well with a platinum wire and a blow-pipe flame.
7. To begin an analysis before one has got together one's apparatus in proper shape.
8. To give a student a mixture of orthoclase, potassium sulphocyanate, and benzoic acid as an unknown. Such a mixture does not occur in nature and illustrates nothing. The object of analysis is to teach the student the art of investigation. It is very seldom necessary to analyze the ruins of a drug store which has been wrecked by an explosion.

*Wilder D. Bancroft*

**Die elektrischen Eigenschaften und die Bedeutung des Selens für die Elektrotechnik.** By Chr. Ries. 2nd Ed. 25 × 17 cm; pp. 187. Berlin: Administration der Fachzeitschrift "Der Mechaniker," 1913. Price: 5 marks.—The author seems to consider that selenium occurs chiefly as a by-product in the manufacture of sulphuric acid by the chamber process. The reviewer has no figures with which to refute this; but he is strongly of the opinion that if there were any real market for selenium, we should get our selenium as a by-product from electrolytic copper refining. The author has written an admirable monograph on the properties and uses of selenium. He considers the abnormal light sensitiveness of some selenium cells as due to moisture. There has been a dispute whether selenium is hygroscopic or not. The author settles it in the simplest possible way by stating, p. 54, that selenium may be either, depending on the method of preparation.

There seems to be a difficulty in regard to the action of light of different wave lengths. On p. 57 the author states that red and blue light act in the same way on the cells regardless whether these latter are in the normal or the abnormal state. This seems very improbable and Pfund is quoted, p. 84, as finding a distinct maximum of sensitiveness in the red at about  $7000\mu$ .

The author pictures to himself the changes in illuminated selenium somewhat as follows, p. 125:

"The action of light on the conductivity of selenium is a resonance phenomenon. Light of definite wave lengths starts up those electrons, whose oscillation period is the same as that of the exciting light, and makes them vibrate. The resonance motions due to the absorption of light act only as discharging agents for vibrations which already exist within the atom. The changes in the conductivity of selenium are caused by the visible (blue, violet) rays of light, these oscillations being much slower, as everybody knows, than those of ultra-violet light. Therefore the electrons set free from selenium by the visible light have a relatively low initial velocity and consequently cannot leave the substance; but pile up instead on the illuminated surface of the selenium. According to the modern views of the conductance of metals, the passage of a current is accompanied by the motion of electrons along the conductor. Since light increases the number of electrons available for carrying the current, it increases the conductance of the illuminated surface. The existence of different forms of selenium in each cell accounts for the cell responding to such a range of the spectrum. As the light penetrates further into the selenium, it sets free electrons from the deeper layers, and the freedom of motion of the electrons increases with increasing thickness of the conducting layer."

The chief commercial uses of metallic selenium are: working relays to sound signals, to put out lights, or to sort coffee beans, p. 144; telephoning by means of light; for electrical transfer of pictures: as a coherer in wireless telegraphy.

Wilder D. Bancroft

**Studies in Valency.** By F. H. Loring.  $21 \times 14$  cm; pp. v + 47. London: Simpkin, Marshall, Hamilton, Kent and Co., 1913. Price: 2 shillings, sixpence.—In the preface the author says:

"The object of this little book is to bring to the notice of those interested in chemistry certain relations among the combining powers of the elements, in order that a conception of chemical phenomena may be obtained quite apart from that gained by laboratory practice. It is important, in the author's opinion, that numerical relations should be studied independently, so that new lines of experiment may be suggested. It is necessary to extend or refute theories by research. At the same time, it is important to know the theoretical views advanced by those who are specializing in any one direction."

The following quotation, p. 31, is not an unfair one. "Consider, then, for purposes of argument, or as a *suggestive hypothesis*, the inactive gases as a special case of free ions, having by theoretical analysis the characteristics of a salt in solution, but with this difference, that they are endowed with enormously greater internal charges of electricity. This idea lends itself to a form of direct proof, since the atomic weights of the higher members of the inactive group

may be represented by the combination of a base-forming element or component with an acid-forming element or component, plus an intermediary factor that is either 7.5 or some multiple of this value . . . .

"Retracing this argument, it will be seen that, in the case of electrolytes, the ions may not always be physically separated from each other in the bulk of the electrolyte; or, rather, if there were more atomic electricity present, the dissociation would not take place.

"Whence comes this vastly greater quantity of electricity in the assumed case of the inactive gases? The only answer the table affords is that the value 7.5 is atomic electricity itself, existing in a highly polymerized or molecular state, granting the atomic theory of electricity that has been proved by means of many independent researches. *The evidence, however, is not scientifically sufficient*, but it tallies in general character with Ramsay's Theory of Chemical Action, in which NaCl would be represented as  $\text{Na}n\text{ECl}$ , E being a unit or bond of electricity. In the present case the mathematical formula, for example, becomes  $\text{Ca} + n\text{E} + \text{Cl} = \text{Kr}$ ."

*Wilder D. Bancroft*

**Metallic Alloys.** By G. H. Culliver. Second edition. 20 × 14 cm; pp. v + 309. Philadelphia: J. B. Lippincott Company, 1913. Price: \$3.25.—The second edition of this book is a very great improvement over the old edition. It is very much larger, contains a large lot of new material, and has been brought as nearly up-to-date as textbooks to-day. The book contains a description of the preparation and methods of studying specimens of alloys, the general discussion of alloys themselves, showing types of curves obtained in alloy work, and then a specific study of alloys themselves. The treatment is in the order of binary and ternary alloys, treating first alloys where no compounds are formed, and alloys where definite chemical compounds exist. The treatment is in the order of the solubility of one component in the other. The book is designed to give students in metallography and engineering an idea of the minute structure of alloys. Physical changes in the solid state during annealing, etc., are treated in a general way. The application of the Phase Rule to metallography is also treated with such important phenomena as different rates of cooling during casting will give rise to. Chapters are given on bronzes and brasses and on the steels, with considerable discussion of the special steels. An interesting chapter is given on the use of the microscope in engineering practice in which a number of interesting instances, where the causes of accidents have been determined by the use of a microscope, show that a single microscopic examination can, in a number of cases, locate the trouble, without a large amount of chemical analysis, which in many cases would even be insufficient to determine the source of the trouble. The later developments in alloy work are given brief mention at least in this book. It is not meant to be a practical handbook, but rather a textbook than otherwise. It is profusely illustrated by a number of photomicrographs, the book containing in all 310 illustrations. References to the original literature are given at the ends of the chapters. The book is printed on good paper and is a welcome addition to the literature of metallography.

The references would be more easily followed if they were included at the foot of each page rather than at the ends of the chapters. The inaccuracies in the book are very few indeed.

*C. W. Bennett*



**Chemical Theory and Calculations.** By F. J. Wilson and I. M. Heilbron. 19 × 13 cm; pp. 126. New York: D. Van Nostrand Co., 1912. Price: \$1.00.—“This little book “contains elements of chemical theory distinct from descriptive chemistry.” The material is arranged with some description and problems at the ends of the chapters, so that the student can work out the problems for himself. The arrangement of the material is logical and the calculations are practical. The book contains chapters on the Metric System, Density Measurements, Thermometry, Gas Laws, Solubility, Atomic Weights, Valency, The Periodic Law, Law of Mass Action, Vapor Density, Osmotic Pressure, Dissociation, Thermochemistry, etc.

The book may be found to be of practical value in a recitation course in Physical Chemistry.  
C. W. Bennett

**A Text-Book of Inorganic Chemistry.** By A. F. Holleman. Translated by H. C. Cooper. Fourth English Edition. 15 × 23 cm; pp. viii + 505. New York: John Wiley and Sons, 1912. Price: \$2.50.—The previous English edition was reviewed at some length (13, 734). It will therefore suffice to call attention to the appearance of this one. In the preface the translator says: “Very many of the descriptive portions have been rewritten, notably those in the sulphur oxides and acids, sodium hydroxide and carbonate, radioactive elements, and platinum, as well as the sections on thermo-chemistry, colloids, and the iron-carbon system, while the subjects of stability and the reality of molecules and atoms furnish new material.”  
Wilder D. Bancroft

**General Index to the Chemical News.** 20 × 26 cm; pp. 712. London: The Chemical News, 1913. Price: 2 pounds.—The publishers have issued a name and subject index to the first hundred volumes of the Chemical News. There is no question but that such an index is a great help to the student. The general plan is as follows: Under the names of the authors “all contributions they have made to the Chemical News are enumerated, as well as any personal notes and reviews of their publications, or abstracts of their papers, which may have appeared in its pages. When an author has published work in collaboration with another, as well as in his own name only, it is given under separate headings. Again, a large subject such as ‘Acid’ is subdivided as far as possible. The individual acids are given separately, as well as the word used in its general sense, while ‘Acids’ also constitutes another heading. ‘Alcohol’ and ‘Alcohols,’ ‘Water’ and ‘Waters,’ and metals and their salts are similarly treated. A complete list of Book Reviews and Notices is given under ‘Book’ and every notice also appears under the name of the author of the book. In indexing articles and papers the spelling and nomenclature originally used by the authors are exactly followed; hence, ‘sumac’ and ‘sumach’ will be found and ‘radicle’ and ‘radical.’ [This seems a mistake.] Where cross references have been thought to be necessary they have been inserted, and every effort has been made to enable readers of the Chemical News to look up quickly and easily any subjects which have appeared in its pages, however fragmentary and incomplete their knowledge or recollections of them may be.”  
Wilder D. Bancroft

**Tables annuelles internationales de constantes et données numériques.** Edited by Ch. Marie. Vol. II. 23 × 28 cm; pp. v + 758. Paris: Gauthier-Villars, 1913.—The second volume of the Annual Tables is fully as valuable as the first one and perhaps more so. There seems to be less space wasted. There will always be a question as to what should or should not be included. The chemist will probably feel that a good deal of space is given to spectroscopic data, especially since these are readily available in the same form. On the other hand, it may be that the physicists wish these data. It is a serious problem for the editor to decide whether or where he shall draw the line, and yet the financial side must be kept in mind. For the present the expenses are defrayed more or less completely by contributions; but it is eminently desirable that the Tables should eventually become self-supporting. In order to do this, the editor must either supply what the scientific public wants or must train the scientific public up to wanting what the editor furnishes. *Wilder D. Bancroft*

**Annalen der Natur- und Kulturphilosophie.** Edited by Wilhelm Ostwald and Rudolf Goldscheid. Leipzig: Verlag Unesma, 1913. Price: 14 marks per volume.—Eight volumes of the *Annalen der Naturphilosophie* have appeared and it has now been decided to broaden the scope of the journal. The twelfth volume appears therefore under the new title, *Annalen der Natur- und Kulturphilosophie* with Rudolf Goldscheid as associate editor and a change of publisher. *Wilder D. Bancroft*

**Chemical Arithmetic and Calculation of Furnace Charges.** By Régis Chauvenet. 16 × 23 cm; pp. vii + 302. Philadelphia: J. B. Lippincott Company, 1912. Price: \$4.00.—The book comprises an elementary treatise on chemical calculations, examples being given in the following subjects: Metric System; thermometer conversions; quantitative calculations of chemical equations; calculation of formulae; atomic and molecular weights; calculations in freezing point, boiling point, and vapor density; determinations of molecular weights; gas laws; specific gravity; assaying; volumetric analysis; and the calculation of furnace charges in metallurgy. Numerous tables are given in which chemical factors, percentage composition of substances, molecular weights, specific gravities, and melting points are contained. The author, on page 6, states the situation as regards chemical arithmetic very clearly.

"Many of the explanations in the text will strike the expert as puerile. They are meant to be. Nothing more astonishes the writer than the inability of many technical men to attack the simplest problems. Graduates in chemistry, with mathematics enough to compute bridge strains, turn pale at the idea of 'tackling' an elementary case of stoichiometry. 'Please assume, to begin with, that I have forgotten all that, if I ever knew it,' would be a fair average estimate of their attitude. Excepting, then, the already excepted 'fundamenta,' all else is explained where there seemed to be the slightest chance for misapprehension."

This, it is believed, is not on account of the fact that chemical arithmetic is hard, but because the chemist does not always think as he should. The book may therefore be taken as an attempt to aid the man who does not have the gift of a stoichiometrical mind.

In the second part of the book the calculation of furnace charges in metallurgy is taken up, in which the author explains fully the methods of calculating

a charge for an ore of definite composition given fluxes of definite composition, to furnish a product, slag, etc., of definite composition. The author hopes that the exact calculation will soon replace the old method of "a lot of ore, a lot of coke, and about a quarter of a lot of limestone."

The book is printed in an attractive manner on good paper, and is nicely bound.  
C. W. Bennett

## ERRATA

The following corrections should be made in the paper entitled "The Internal Pressures of Liquids" by A. P. Mathews, Jour. Phys. Chem., 17, 603 (1913):

- p. 610.  $V_2$  of the 12th line should be  $V_1$ .
- p. 615. Table 4. omit 2.287 for propyl acetate; add 2.26 (at 199°-236°) for alcohol, Column 4.
- p. 616. Formula 16 should be:  $a = 3CN^{1/2}V_cT_c/S$ .
- p. 616. Formula 17 should be:  $a = 3CN^{1/2}P_cV_c^2/R$  ergs.
- p. 616. Line 23, the comma after Bötvs should be a period.
- p. 617. Formula:  $N^{1/2}TV_c^{2/3}/T_c = K_cR/P_c$  should be  
 $N^{1/2}TV_c^{2/3}/T_c = K_cR/3P_c$ .
- p. 621. Formula 32,  $\gamma$  should be  $\lambda$ .
- p. 624. Column 6 in formula for "a", the exponent  $1/3$  after  $(T_c - T)$  has slipped down.
- p. 628. Line 10. In place of  $(T_c/T_c - T)^{1/3}$  read  $(T_c/(T_c - T))^{1/3}$ .
- p. 628. Formula 35 should be  $S^2 = R(d_1 - d_c)T_c^{1/3}/(T_c - T)^{1/3}$  MP<sub>c</sub>.
- p. 628. Formula 36 should have  $d_1$  in place of  $d_c$ .



## NAME INDEX

### *To Papers*

Anderson, Ernest and H. A. Noyes	A simple, inexpensive calorimeter for determining the heat of solution and of neutralization, . . . . .	249
Bacon, Nathaniel T.	On the mechanical processes of combination, . . . . .	762
Baker, R. E.	See Frary, Mitchell and Baker, . . . . .	33
Bancroft, Wilder D.	The photographic plate, IX, . . . . .	93
Bancroft, Wilder D.	The theory of emulsification, V, . . . . .	501
Bancroft, Wilder D.	The electrochemistry of light, X, . . . . .	596
Barneier, F. E.	See Mathews and Barneier, . . . . .	682
Bennett, C. W. and H. N. Gilbert	Some tests of the Edison storage battery, . . . . .	322
Bennett, C. W. and C. O. Brown	Concentration changes in the electrolysis of copper sulphate solutions, . . . . .	373
Bennett, C. W. and C. O. Brown	Rapid refining of copper with a rotating cathode, . . . . .	685
Beutner, Richard	New electric properties of a semipermeable membrane of copper ferrocyanide, . . . . .	344
Briggs, T. Roland	The electrochemical production of colloidal copper, . . . . .	281
Brown, C. O.	See Bennett and Brown, . . . . .	373, 685
Bunce, E. H. and L. S. Finch	Chromic oxide jellies, . . . . .	769
Davison, A. W.	Experiments in dyeing, . . . . .	737
Dewey, L. H.	See Mathews and Dewey, . . . . .	217, 230
Doyle, Henry L.	Colloidal suspension of graphite, . . . . .	390
Farnau, E. F.	Luminescence, . . . . .	637
Finch, L. S.	See Bunce and Finch, . . . . .	769
Frankforter, George B. and Francis C. Frary	Equilibria in systems containing alcohol, salts and water, including a new method of alcohol analysis, . . . . .	402
Frary, Francis C., Ralph W. Mitchell and Russell E. Baker	The direct production of positives in the camera by means of thiourea and its compounds, . . . . .	33
Frary, F. C.	See Frankforter and Frary, . . . . .	402
Garver, M. M.	On the molecular constitution of the free surfaces of liquids, . . . . .	386
Gilbert, H. N.	See Bennett and Gilbert, . . . . .	322
Gordon, M. A.	The silver equivalent of hydroquinone, . . . . .	47
Hulett, G. A.	See Quinn and Hulett, . . . . .	779
Hulett, G. A.	See Taylor and Hulett, . . . . .	565, 755
Ives, Herbert E.	Recent advances in our knowledge of cold light, . . . . .	26

- Ives, Herbert E. The present condition of color photography, . . . 41
- Leighton, Alan The photosensitiveness of Fehling's solution, . . . 205
- Leighton, Alan Effect of light on decomposition voltage, . . . 695
- Leighton, Alan See Perley and Leighton, . . . 235
- Lloyd, Stewart J. Conductivity maxima in glycerine, . . . 264
- Lloyd, Stewart J. Electrical conductivity of solutions of molybdenum pentachloride, . . . 592
- Lohr, J. M. The tensile strengths of the copper-zinc alloys, . . . 1
- Lohr, J. M. Color photography of luminescence, . . . 675
- Mathews, Albert P. A method of determining "a" of van der Waals' equation, . . . 154
- Mathews, Albert P. The relation of the value "a" of van der Waals' equation to the molecular weight and the number of valences of the molecule, . . . 181
- Mathews, Albert P. The valence of chlorine as determined from the molecular cohesion of chlorine compounds, . . . 252
- Mathews, Albert P. A note on the structure of acetylene, . . . 320
- Mathews, Albert P. The valence of oxygen, sulphur, nitrogen, and phosphorus determined from the molecular cohesion, . . . 331
- Mathews, Albert P. The valence of the argon group as determined from the molecular cohesion, . . . 337
- Mathews, Albert P. The significance of the relationship between molecular cohesion and the product of the molecular weight and the number of valences, . . . 481
- Mathews, Albert P. Do molecules attract cohesively inversely as the square of the distance? . . . 520
- Mathews, Albert P. The internal pressures of liquids, . . . 603
- Mathews, J. Howard and Leon H. Dewey A quantitative study of some photochemical effects produced by ultraviolet light, . . . 211
- Mathews, J. Howard and Leon H. Dewey The production of photochemically active rays in ordinary chemical reactions, . . . 230
- Mathews, J. Howard and Floyd E. Barneier The rôle played by the carbonate in photographic development, . . . 682
- Mitchell, R. W. See Frary, Mitchell and Baker, . . . 33
- Newman, F. R. Action of calcium chloride on roads, . . . 703
- Noyes, H. A. See Anderson and Noyes, . . . 249
- Osborne, J. L. The filtration of barium sulphate, . . . 629
- Parker, Edward G. Studies on cellulose, . . . 219
- Perley, G. A. and Alan Leighton Preliminary studies on direct photographic positives, . . . 235
- Pingree, L. N. See Young and Pingree, . . . 657

Quinn, Elton L. and George A. Hulett	The atomic weight of cadmium by the investigation of cadmium chloride and cadmium bromide, . . . . .	779
Shaw, Leon I.	Studies of the electrical conductance of non-aqueous solutions, . . . . .	162
Taylor, Guy B. and George A. Hulett	The dissociation of mercuric oxide, . . . . .	565
Taylor, Guy B. and George A. Hulett	Mercuric oxide, . . . . .	755
Tyrer, D.	Some new relations between the physical properties of liquids, . . . . .	717
Weiser, H. B.	Indirect analysis of a ferric oxide gel, . . . . .	536
Wilber, D. T.	Anhydrous sodium sulphate and water, . . . . .	556
Young, S. W., and L. N. Pingree,	The effect of light on the electrical charge of suspended particles, . . . . .	657

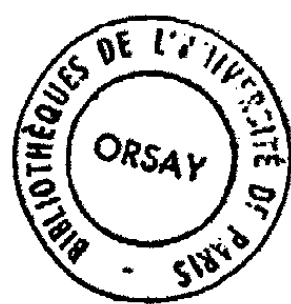



## NAME INDEX

### To New Books

Allyn, Lewis B.	Elementary Applied Chemistry, . . .	370
Allmand, A. J.	The Principles of Applied Electrochemistry, . . .	477
Baly, R. C. C.	Spectroscopy, . . .	88
Barclay, W. R. and C. H. Hainsworth	Electroplating, . . .	715
Benrath, Alfred	Lehrbuch der Photochemie, . . .	561
Biltz, Wilhelm	Ausführung qualitativer Analyse, . . .	801
Bragg, W. H.	Studies in Radioactivity, . . .	83
Brunswig, H.	Explosives, . . .	277
Burgess, G. K., and H. Le Chatelier	The Measurement of High Temperatures, . . .	177
Cady, Hamilton P.	Inorganic Chemistry, . . .	369
Cassuto, Leonardo	Der kolloide Zustand der Materie, . . .	713
Castell-Evans, John	Physico-chemical Tables, Vol. II, . . .	635
Chauvenet, Regis	Chemical Arithmetic and Calculation, . . .	806
Chemical News, General Index to		805
Danneel, Heinrich and Julius Meyer	Jahrbuch der Elektrochemie, Vol. XIII, . . .	564
Dreaper, W. P.	Notes on Chemical Research, . . .	562
Duff, A. Wilmer	A Text-book on Physics, . . .	180
Ekeley, John B.	A Laboratory Manual of Inorganic Chemistry, . . .	180
Findlay, Alexander	Osmotic Pressure, . . .	563
Foerster, F.	Beiträge zur Kenntniss des elektrochemischen Verhaltens des Eisens, . . .	635
Gooch, Frank Austin	Methods of Analysis, . . .	632
Gulliver, G. H.	Metallic Alloys, . . .	804
Hatschek, Emil	An Introduction to the Physics and Chemistry of Colloids, . . .	711
Havard, F. T.	Refractories and Furnaces, . . .	365
Henderson, Lawrence J.	The Fitness of the Environment, . . .	707
Hinrichsen, F. W.	Das Materialprüfungswesen, . . .	370
van't Hoff, J. H.	Untersuchungen über die Bildungsverhältnisse der ozeanischen Salzablagerungen, . . .	279
Holleman, A. F.	A Text-book of Inorganic Chemistry, . . .	805
Hoover, Theodore J.	Concentrating Ores by Flotation, . . .	633
von Hübl, Arthur Freiherrn	Die Dreifarbenphotographie, . . .	92
Index, general, to Chemical News,		805
Jaeger, F. M.	Eine Anleitung zur ausführung physikochemischer Messungen bei höheren Temperaturen, . . .	716
Jones, Lauder W.	A Laboratory Outline of Organic Chemistry, . . .	91
Kayser, H.	Handbuch der Spectroscopic, Vol. VI, . . .	177

Knox, Joseph	Elementary Chemical Theory and Calculations,	179
Leiser, Richard	Elektrische Doppelbrechung der Kohlenstoffverbindungen,	179
Loeb, Jacques	The Mechanistic Conception of Life,	268
Loring, F. H.	Studies in Valency,	803
Main, W.	Le Celluloid et ses Succédanés,	564
Makower, W., and H. Geiger,	Practical Measurements in Radioactivity,	372
Marie, Ch.	Tables annuelles internationales, Vol. II,	806
Martin, Geoffrey	Triumphs and Wonders of Modern Chemistry,	363
Mellor, J. W.	Modern Inorganic Chemistry,	474
Molinari, Ettore	Treatise on General and Industrial Inorganic Chemistry,	558
Moody, Herbert R.	A College Text-book on Qualitative Analysis,	371
Müller, Erich	Elektrochemisches Praktikum,	715
Norris, James F.	The Principles of Organic Chemistry,	280
Ostwald, Wilhelm and Rudolf Goldscheid	Annalen der Natur- und Kulturphilosophie,	806
Ostwald, Wolfgang	Die neuere Entwicklung der Kolloidchemie,	479
Ostwald, Wolfgang	Grundriss der Kolloidchemie,	559
Perrin, Jean	Les Atomes	563
Pope, F. G.	Modern Research in Organic Chemistry,	714
Ries, Chr.	Die elektrischen Eigenschaften und die Bedeutung des Selen für die Elektrotechnik,	802
Sackur, Otto	Lehrbuch der Thermochemie und Thermodynamik,	178
Sauveur, Albert	The Metallography of Iron and Steel,	275
Senter, G.	Outlines of Physical Chemistry,	479
Sommerfeldt, E.	Die Kristallgruppen nebst ihren Beziehungen zu den Raumgittern,	480
Stieglitz, Julius	The Elements of Qualitative Chemical Analysis,	178
Svedberg, The	Die Existenz der Moleküle,	361
Thorpe, Sir Edward	Dictionary of Applied Chemistry, Vols. II, III, IV,	86, 709, 799
Unger, M. S. H.	Review Questions and Problems in Chemistry,	371
Urbain, G.	Introduction a l'Étude de la Spectrochimie,	636
Urbain, G.	Einführung in die Spektrochemie,	716
von Weimarn, P. P.	Grundzüge der Dispersoidchemie,	478
Wilson, F. J., and I. M. Heilbron,	Chemical Theory and Calculations,	805
Ziwet, Alexander and Peter Field	Introduction to Analytical Mechanics,	371
Zsigmondy, Richard	Kolloidchemie,	560



## SUBJECT INDEX

*Exclusive of New Books*

Acetylene, a note on the structure of, . . . . .	320
Action of calcium chloride on roads, . . . . .	703
Active rays, production of photochemically, in ordinary chemical reactions, . . . . .	230
Advances, recent, in our knowledge of cold light, . . . . .	26
Alcohol analysis, new method of, . . . . .	402
Alcohol, equilibria in systems containing salts, water and, . . . . .	402
Alloys, the tensile strength of the copper-zinc, . . . . .	1
Analysis, indirect, of a ferric oxide gel, . . . . .	536
Analysis of alcohol, a new method for, . . . . .	402
Anhydrous sodium sulphate and water, . . . . .	556
Argon group, the valence of the, as determined from the molecular cohesion, . . . . .	337
Atomic weight of cadmium by the investigation of cadmium chloride and cadmium bromide, . . . . .	779
Attract cohesively, do molecules? . . . . .	520
Barium sulphate, the filtration of, . . . . .	629
Battery, Edison storage, some tests of, . . . . .	322
Bromide, cadmium, the atomic weight of cadmium by the investigation of cadmium chloride and, . . . . .	779
Cadmium, the atomic weight of, by the investigation of cadmium chloride and cadmium bromide, . . . . .	779
Cadmium bromide and cadmium chloride, the atomic weight of cadmium by the investigation of, . . . . .	779
Cadmium chloride and cadmium bromide, the atomic weight of cadmium by the investigation of, . . . . .	779
Calcium chloride, action on roads of, . . . . .	703
Calorimeter for determining the heat of solution and of neutralization . . . . .	294
Camera, the direct production of positives in the, by means of thiourea and its compounds, . . . . .	33
Carbonate, rôle played by the, in photographic development, . . . . .	682
Cathode, rapid refining of copper with a rotating, . . . . .	685
Cellulose, studies on, . . . . .	219
Changes of concentration in the electrolysis of copper sulphate solutions, . . . . .	373
Charge, the effect of light on the electrical, of suspended particles, . . . . .	657
Chemical reactions, the production of photochemically active rays in ordinary, . . . . .	230
Chloride, action on roads of calcium, . . . . .	703
Chloride, investigation of cadmium, . . . . .	779
Chlorine, the valence of, as determined from the molecular cohesion of chlorine compounds, . . . . .	252
Chlorine compounds, the valence of chlorine as determined from the molecular cohesion of, . . . . .	252
Chromic oxide jellies, . . . . .	769
Cohesion, molecular, of chlorine compounds, the valence of chlorine as determined from the, . . . . .	252

Cohesion, molecular, the significance of the relationship between, and the product of the molecular weight and the number of valences, . . . . .	481
Cohesion, molecular, the valence of oxygen, sulphur, nitrogen, and phosphorus determined from the, . . . . .	331
Cohesion, molecular, the valence of the argon group as determined from the, . . . . .	337
Cohesively, do molecules attract, inversely as the square of the distance . . . . .	520
Cold light, recent advances in our knowledge of, . . . . .	26
Colloidal copper, the electrochemical production of, . . . . .	281
Colloidal suspension of graphite, . . . . .	390
Color photography of luminescence, . . . . .	675
Color photography, the present condition of, . . . . .	41
Combination, on the mechanical processes of, . . . . .	762
Compounds, chlorine, molecular cohesion of, . . . . .	252
Compounds of thiourea, direct production of positives in the camera by means of, . . . . .	33
Condition, the present, of color photography, . . . . .	41
Concentration changes in the electrolysis of copper sulphate solutions, . . . . .	373
Conductance, studies of electrical, of non-aqueous solutions, . . . . .	162
Conductivity, electrical, of solutions of molybdenum pentachloride, . . . . .	592
Conductivity maxima in glycerine, . . . . .	264
Constitution, molecular, of the free surfaces of liquids, . . . . .	386
Copper, colloidal, the electrochemical production of, . . . . .	281
Copper ferrocyanide, new electric properties of a semipermeable membrane of, . . . . .	344
Copper, rapid refining of, with a rotating cathode, . . . . .	685
Copper sulphate solutions, concentration changes in the electrolysis of, . . . . .	373
Copper-zinc alloys, the tensile strengths of the, . . . . .	1
Decomposition voltage, effect of light on, . . . . .	695
Determining "a" of van der Waals' equation, the method of, . . . . .	154
Determining the heat of solution and of neutralization, . . . . .	249
Development, photographic, rôle played by the carbonate in, . . . . .	682
Direct photographic positives . . . . .	235
Direct production of positives in the camera by means of thiourea and its compounds, . . . . .	33
Dissociation of mercuric oxide, the, . . . . .	565
Distance, square of, do molecules attract cohesively inversely as the? . . . . .	520
Dyeing, experiments in, . . . . .	737
Edison storage battery, some tests of the, . . . . .	322
Effect of light on decomposition voltage, . . . . .	695
Effect of light on the electrical charge of suspended particles, . . . . .	657
Effects produced by ultra-violet light, a quantitative study of some, . . . . .	211
Electric properties, new, of a semipermeable membrane of copper ferrocyanide, . . . . .	344
Electrical charge of suspended particles, effect of light on the, . . . . .	657
Electrical conductance of non-aqueous solutions, studies of, . . . . .	162
Electrical conductivity of solutions of molybdenum pentachloride, . . . . .	592
Electrical production of colloidal copper, . . . . .	281
Electrochemistry of light, . . . . .	596

Electrolysis of copper sulphate solutions, concentration changes in, . . . . .	373
Emulsification, theory of, . . . . .	501
Equation, van der Waals', a method of determining "a" of, . . . . .	154
Equation, van der Waals', the relation of the value "a" of, . . . . .	181
Equilibria in systems containing alcohol, salts, and water, including a new method of alcohol analysis, . . . . .	402
Equivalent, silver, of hydroquinone, . . . . .	47
Experiments in dyeing, . . . . .	737
Fehling's solution, the photosensitiveness of, . . . . .	205
Ferric oxide gel, indirect analysis of a, . . . . .	536
Ferrocyanide, semipermeable membrane of copper, . . . . .	344
Filtration of barium sulphate, . . . . .	629
Free surfaces of liquids, molecular constitution of the, . . . . .	386
Gel, ferric oxide, indirect analysis of a, . . . . .	536
Glycerine, conductivity maxima in, . . . . .	264
Graphite, colloidal suspension of, . . . . .	390
Group, argon, valence of, . . . . .	337
Heat of solution and of neutralization, simple inexpensive calorimeter for determining the, . . . . .	249
Hydroquinone, the silver equivalent of, . . . . .	47
Indirect analysis of a ferric oxide gel, . . . . .	536
Inexpensive calorimeter, simple, for determining the heat of solution, . . . . .	249
Internal pressures of liquids, . . . . .	603
Inversely as the square of the distance, do molecules attract cohesively? . . . . .	520
Investigation of cadmium chloride and cadmium bromide, atomic weight of cadmium by, . . . . .	779
Jellies, chromic oxide, . . . . .	769
Knowledge, recent advance in our, of cold light, . . . . .	26
Light, cold, recent advances in our knowledge of, . . . . .	26
Light, effect of, on decomposition voltage, . . . . .	695
Light, effect of, on the electrical charge of suspended particles, . . . . .	657
Light, electrochemistry of, . . . . .	596
Light, ultra-violet, a quantitative study of some photochemical effects pro- duced by, . . . . .	211
Liquids, on the molecular constitution of free surfaces of, . . . . .	386
Liquids, internal pressures of, . . . . .	603
Liquids, some new relations between the physical properties of, . . . . .	717
Luminescence, . . . . .	637
Luminescence, color photography of, . . . . .	675
Maxima, conductivity, in glycerine, . . . . .	264
Mechanical processes of combination, . . . . .	762
Membrane, semipermeable, of copper ferrocyanide, . . . . .	344
Mercuric oxide, . . . . .	755
Mercuric oxide, the dissociation of, . . . . .	565
Method of determining "a" of van der Waals' equation, . . . . .	154
Molecular cohesion of chlorine compounds, the valence of chlorine as deter- mined from the, . . . . .	252

Molecular cohesion, the significance of the relationship between, and the product of the molecular weight and the number of valences, . . . . .	481
Molecular cohesion, the valence of the argon group as determined from the, . . . . .	337
Molecular cohesion, the valence of oxygen, sulphur, nitrogen, and phosphorus determined from the, . . . . .	331
Molecular constitution of the free surfaces of liquids, . . . . .	386
Molecular weight, the relationship between molecular cohesion and the product of the, . . . . .	481
Molecular weight, the relation of the value "a" of van der Waals' equation to the, . . . . .	181
Molecule, the number of valences of, . . . . .	181
Molecules, do, attract cohesively inversely as the square of the distance? . . . . .	520
Molybdenum pentachloride, electrical conductivity of solutions of, . . . . .	592
Neutralization, calorimeter for determining the heat of solution and of, . . . . .	249
New electric properties of a semipermeable membrane of copper ferrocyanide, . . . . .	344
New method of alcohol analysis, . . . . .	402
New relations between the physical properties of liquids, . . . . .	717
Nitrogen, the valence of, as determined from the molecular cohesion, . . . . .	331
Non-aqueous solutions, studies of the electrical conductance of, . . . . .	162
Note on the structure of acetylene, . . . . .	320
Number of valences of the molecule, . . . . .	181
Number of valences, the significance of, the relationship between molecular cohesion and the product of the molecular weight and the, . . . . .	481
Ordinary chemical reactions, production of photochemically active rays in, . . . . .	230
Oxide gel, indirect analysis of a ferric, . . . . .	536
Oxide jellies, chromic, . . . . .	769
Oxide, mercuric, . . . . .	755
Oxide, mercuric, the dissociation of, . . . . .	565
Oxygen, valence of, determined from the molecular cohesion, . . . . .	331
Particles, suspended, the effect of light on the electrical charge of, . . . . .	657
Pentachloride, molybdenum, electrical conductivity of solutions of, . . . . .	592
Phosphorus, valence of, determined from the molecular cohesion, . . . . .	331
Photochemically active rays, the production of, in ordinary chemical reactions, . . . . .	230
Photochemical effects, a quantitative study of, . . . . .	211
Photographic development, rôle played by the carbonate in, . . . . .	682
Photographic plate, . . . . .	93
Photography, color, of luminescence, . . . . .	675
Photographic positives, preliminary studies on direct, . . . . .	235
Photography, color, present condition of, . . . . .	41
Photosensitiveness of Fehling's solution, . . . . .	205
Physical properties of liquids, some new relations between the, . . . . .	717
Plate, photographic, . . . . .	93
Positives, preliminary studies on direct photographic, . . . . .	235
Positives, direct production of, in the camera by means of thiourea and its compounds, . . . . .	33
Preliminary studies on direct photographic positives, . . . . .	235

*Subject Index*

817

Pressures of liquids, internal, . . . . .	603
Present condition of color photography, . . . . .	41
Processes, mechanical, of combination, . . . . .	762
Product of the molecular weight and the number of valences, . . . . .	481
Production, direct, of positives in the camera, . . . . .	33
Production of colloidal copper, electrochemical, . . . . .	281
Production of photochemically active rays in ordinary chemical reactions, . . . . .	230
Properties, new electric, of a semipermeable membrane of copper ferrocyanide, . . . . .	344
Properties of liquids, some new relations between the physical, . . . . .	717
Quantitative study of some photochemical effects produced by ultra-violet light, . . . . .	211
Rapid refining of copper with a rotating cathode, . . . . .	685
Rays, photochemically active, production of, . . . . .	230
Reactions, production of photochemically active rays in ordinary chemical, . . . . .	230
Recent advances in our knowledge of cold light, . . . . .	26
Refining, rapid, of copper with a rotating cathode, . . . . .	685
Relation of the value "a" of van der Waals' equation to the molecular weight and the number of valences of the molecule, . . . . .	181
Relations between the physical properties of liquids, some new, . . . . .	717
Relationship, significance of the, between molecular cohesion and the product of the molecular weight, and the number of valences, . . . . .	481
Roads, action of calcium chloride on, . . . . .	703
Rôle played by the carbonate in photographic development, . . . . .	682
Rotating cathode, rapid refining of copper with a, . . . . .	685
Salts, water and alcohol, equilibria in systems containing, . . . . .	402
Semipermeable membrane of copper ferrocyanide, new electric properties of a, . . . . .	344
Significance of the relationship between molecular cohesion and the product of the molecular weight and the number of valences, . . . . .	481
Simple, inexpensive calorimeter for determining the heat of solution and of neutralization, . . . . .	249
Silver equivalent of hydroquinone, . . . . .	47
Sodium sulphate, anhydrous, and water, . . . . .	556
Solution, calorimeter for determining the heat of, . . . . .	249
Solution, Fehling's, photosensitiveness of, . . . . .	205
Solutions, concentration changes in the electrolysis of copper sulphates, . . . . .	373
Solutions, non-aqueous, studies of the electrical conductance of, . . . . .	162
Solutions of molybdenum pentachloride, electrical conductivity of, . . . . .	592
Some new relations between the physical properties of liquids, . . . . .	717
Some photochemical effects, . . . . .	211
Some tests of the Edison storage battery, . . . . .	322
Square of the distance, do molecules attract cohesively inversely as the? . . . . .	520
Storage battery, Edison, some tests of, . . . . .	322
Strength, tensile, of the copper-zinc alloys, . . . . .	1
Structure of acetylene, a note on the, . . . . .	320
Studies, preliminary, on direct photographic positives, . . . . .	235
Studies of the electrical conductance of non-aqueous solutions, . . . . .	162

Studies on cellulose, . . . . .	219
Study, quantitative, of some photochemical effects, . . . . .	211
Sulphate, anhydrous sodium, and water, . . . . .	556
Sulphate, filtration of barium, . . . . .	629
Sulphate solutions, concentration changes in the electrolysis of copper, . . . . .	373
Sulphur, valence of, determined from the molecular cohesion, . . . . .	331
Surfaces of liquids, molecular constitution of the free, . . . . .	386
Suspended particles, the effect of light on the electrical charge of, . . . . .	657
Suspension, colloidal, of graphite, . . . . .	390
Systems, equilibria in, containing alcohol, salts and water, . . . . .	402
Tensile strength of the copper-zinc alloys, . . . . .	1
Tests of the Edison storage battery, some, . . . . .	322
Theory of emulsification, . . . . .	501
Thiourea and its compounds, the direct production of positives in the camera by means of, . . . . .	33
Ultra-violet light, a quantitative study of some photochemical effects produced by, . . . . .	211
Valence of the argon group as determined from the molecular cohesion, . . . . .	337
Valence of chlorine as determined from the molecular cohesion of chlorine compounds, . . . . .	252
Valence of nitrogen determined from the molecular cohesion, . . . . .	331
Valence of oxygen determined from the molecular cohesion, . . . . .	331
Valence of phosphorus determined from the molecular cohesion, . . . . .	331
Valence of sulphur determined from the molecular cohesion, . . . . .	331
Valences, number of, product of molecular weight and, . . . . .	481
Valences of the molecule, number of, relation of "a" of van der Waals' equation to, . . . . .	181
Value of "a" of van der Waals' equation, relation of, to the molecular weight, . . . . .	181
Van der Waals' equation, a method of determining "a," . . . . .	154
Van der Waals' equation, the relation of the value of "a," . . . . .	181
Voltage, effect of light on decomposition, . . . . .	695
Water, anhydrous sodium sulphate and, . . . . .	556
Water, equilibria in systems containing alcohol, salts and, . . . . .	402
Weight, atomic, of cadmium by the investigation of cadmium chloride and cadmium bromide, . . . . .	779
Weight, molecular, the relation of the value "a" of van der Waals' equation to the, . . . . .	181
Zinc alloys, the tensile strengths of the copper-, . . . . .	1

